

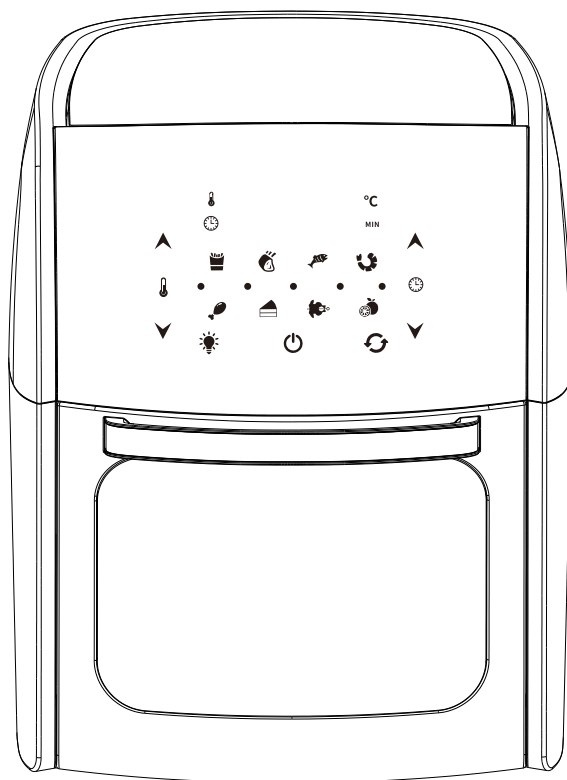

IN220901461V02\_UK

**800-149V70**



**UK  
CA CE**

## AIR OVEN INSTRUCTION MANUAL

The contents base on real subject.

**IMPORTANT, RETAIN FOR FUTURE REFERENCE: READ CAREFULLY**

# ASSEMBLY INSTRUCTION

# Table of Contents

Important Safeguards	01-02
Parts & Accessories	02-04
Using the Accessories	04-06
Using the Digital Control Panel	06-07
Cooking Presets	07-08
General Operating Instructions	08-10
Cooking Chart	10-11
Cleaning & Storage	11
Troubleshooting	11-12
Frequently Asked Questions	12

## **Air circulation fryer, rotisserie, dehydrator and more**

### **Before you begin**

It is very important that you read this entire manual, making certain you are completely familiar with the unit's operation and precautions.

If you have any questions, please contact our customer care center.

Our contact details are below:



0044-800-240-4004



[enquiries@mhstar.co.uk](mailto:enquiries@mhstar.co.uk)

#### **IMPORTER ADDRESS:**

MH STAR UK LTD

Unit 27, Perivale Park,

Horsenden lane South

Perivale, UB6 7RH

MADE IN CHINA

### **The air oven**

It can cook your favourite fried food – it also broils and bakes other favourites like air-fried burgers, calzones and doughnuts. There are eight one-touch presets to set the time and temperature – great for crispy shrimp, fries and southern-style chicken.

There is a rotisserie and dehydrator preset, which preserves fresh fruits and other foods for future use.

### **We all love fried food**

Crispy fried chicken, french fries, coconut shrimp, chicken parmesan, hot spicy wings and much more. Until now, it was impossible to get that crispy-fried crunch and flavour without frying in deep fat or oil.

# IMPORTANT SAFEGUARDS

When using electrical appliances, basic safety precautions should always be followed, including:

- **NEVER IMMERSE** the Main Unit Housing, which contains electrical components and heating elements, in water. Do not rinse under the tap.
- **TO AVOID ELECTRICAL SHOCK, DO NOT** put liquid of any kind into the Main Unit Housing containing the electrical components.
- This appliance has a polarized plug (one blade is wider than the other). **To REDUCE THE RISK OF ELECTRIC SHOCK**, this plug is intended to fit into a polarized outlet only one way. If the plug does not fit fully into the outlet, reverse the plug. If it still does not fit, contact a qualified electrician.
- **DO NOT ATTEMPT** to modify the plug in any way.
- **MAKE SURE** the appliance is plugged into a wall socket. Always make sure that the plug is inserted into the wall socket properly.
- To prevent food contact with the interior upper screen and heat element, **DO NOT OVERFILL** the Rotating Mesh Basket.
- **DO NOT COVER** the Air Intake Vent or Air Outlet Vent while the Air Oven is operating. Doing so will prevent even cooking and may damage the Unit or cause it to overheat.
- **NEVER POUR** oil into the Rotating Mesh Basket. Fire and personal injury could result.
- While cooking, the internal temperature of the Unit is very high. **TO AVOID PERSONAL INJURY**, never place hands inside the Unit unless it is thoroughly cooled.
- This appliance is **NOT INTENDED FOR USE** by persons with reduced physical, sensory, or mental capabilities or a lack of experience and knowledge unless they are **UNDER THE SUPERVISION** of a responsible person or have been given proper instruction in using the appliance. This appliance is **NOT INTENDED FOR USE** by children.
- When cooking, **DO NOT PLACE** the appliance against a wall or against other appliances. Leave at least 10cm free space on the back and sides and above the appliance. Do not place anything on top of the appliance.
- **DO NOT USE** this unit if the plug, the power cord, or the appliance itself is damaged in any way.
- **DO NOT PLACE** the unit on stove top surfaces.
- If the power cord is damaged, **YOU MUST HAVE IT REPLACED** by the manufacturer, its service agent, or a similarly qualified person in order to avoid hazard.
- Keep the appliance and its power cord **OUT OF THE REACH** of children when it is in operation or in the cooling process.
- **KEEP THE POWER CORD AWAY** from hot surfaces. **DO NOT PLUG** in the power cord or operate the Unit controls with wet hands.
- **NEVER CONNECT** this appliance to an external timer switch or separate remote-control system.
- **NEVER USE** this appliance with an extension cord of any kind.
- **DO NOT OPERATE** the appliance on or near combustible materials, such as tablecloths and curtains.
- **DO NOT USE** the unit for any purpose other than described in this manual.
- **NEVER OPERATE** the appliance unattended.
- When in operation, air is released through the Air Outlet Vent. **KEEP YOUR HANDS AND FACE** at a safe distance from the Air Outlet Vent. Also avoid the air while removing the Rotating Mesh Basket from the appliance.
- The Unit's outer surfaces may become hot during use. The Rotating Mesh Basket **WILL BE HOT**.

**WEAR OVEN MITTS** or use the Fetch Tool when handling hot components. Wear oven mitts when handling hot surfaces.

- Should the Unit emit black smoke, **UNPLUG IMMEDIATELY** and wait for smoking to stop before removing oven contents.
- When time has run out, cooking will stop but the fan **WILL CONTINUE RUNNING** for 15 secs. to cool down the Unit.
- Always operate the appliance on a horizontal surface that is level, stable, and noncombustible.
- This appliance is intended for normal household use only. It is not intended for use in commercial or retail environments.
- If the Air Oven is used improperly or for professional or semiprofessional purposes or if it is not used according to the instructions in the user manual, the warranty becomes invalid and the manufacturer will not be held liable for damages.
- Always unplug the appliance after use.
- Let the appliance cool down for approximately 30 mins. before handling cleaning, or storing.
- Make sure the ingredients prepared in this Unit come out cooked to a golden-yellow color rather than dark or brown. Remove burnt remnants.
- The cooktop may smoke the first time it is used. It is not defective and the smoke will burn off within a few minutes.

### **Important**

- Before and after using, hand wash the rotating mesh basket and other cooking accessories. Wipe the outside and inside of the unit, using a warm, damp cloth and mild detergent. Preheat the air oven for a few minutes to burn off any residue.

### **Electric power**

- If the electrical circuit is overloaded with other appliances, your unit may not operate properly. It should be used on a dedicated electrical circuit.

### **Automatic shut down**

This appliance has a built-in 'power off' device, which automatically shuts down the unit when the timer reaches zero. You can manually switch the appliance off by holding the power button for two seconds.

### **Electromagnetic fields (EMF)**

- This appliance applies with all standards regarding electromagnetic fields (EMF). If handled properly and according to the instructions in this user manual, the appliance is safe to use.

### **Parts and accessories**

NOTE: Unpack all listed contents from packaging. Varies by model. Please remove any clear or blue protective film from components.

- |                         |                                  |   |
|-------------------------|----------------------------------|---|
| 1. Main Unit            | 6. Rotating Mesh Basket          | 9. Rotisserie Shaft, Forks & Set Screws |
| 2. Control Panel        | 7. Drip Tray                     | 10. Rotisserie Fetch Tool               |
| 3. Air Intake Vents     | 8a*. Skewers(10)                 |   |
| 4. Hot Air Outlet Vents | 8b*. Adjustable Skewers Racks(2) |   |
| 5. Air Flow Racks       |                                  |   |

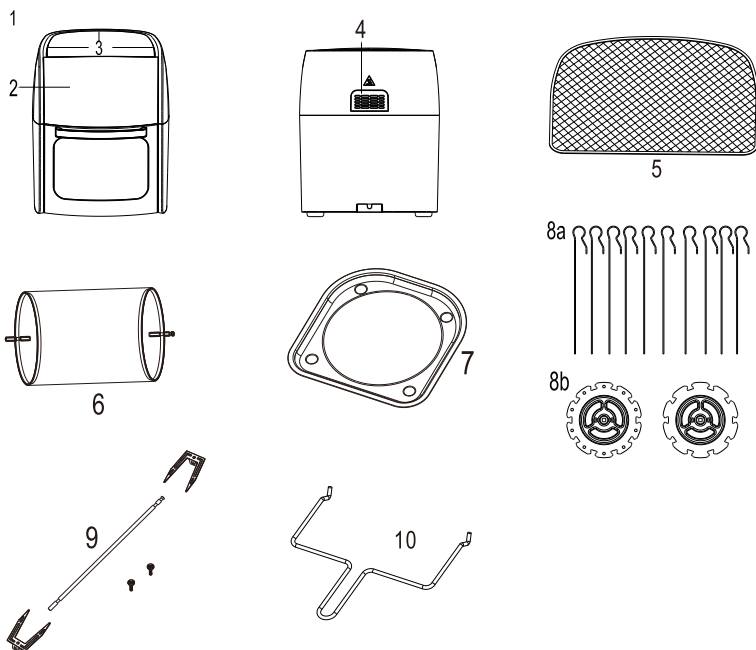

### 5. Air flow racks

Can be used for dehydration, cooking crispy snacks or reheating foods such as pizza.

### 6. Rotating mesh basket

Great for fries, roasted nuts and other snacks. Use the fetch tool to place basket into the unit.

### 7. Drip tray

Cook with the tray in place, so it is easy to clean residue.

### 8a. Skewers (\*optional)

Great for kebabs, meat, fish and vegetables.

### 8b. Adjustable skewer racks (\*optional)

Used for making kebabs. Skewer racks fits over shaft and locks in place with set screws.

### 9. Rotisserie shaft, forks and set screws

Use for roasts and whole chicken. Ensure shaft is lengthwise, through the meat and centre. Slide forks onto shaft from either end, into meat – lock in place with set screws. There are indications on the shaft for set screws. You can adjust the screws closer to the middle if needed – it cannot be adjusted outward towards the ends.

**NOTE:** Ensure roast or chicken is not too large, so it can rotate freely within the oven. Maximum weight for chicken or roast should be 1000-1500g.

### 10. Rotisserie fetch tool

Use to remove cooked roasts and chicken, which have been prepared using the rotisserie or skewer method. Place under rotisserie shaft and lift (left side first), then gently extract the food.

## Important

Check all components are present before using. If parts are missing or damaged, do not use this product. Use the customer service number, located at the back of the manual, to contact the shipper.

NOTE: Some accessories may not be included with the purchase.

## Warning

Forks, skewers and other metal parts are sharp and will get extremely hot during use.

Take great care to avoid injury. Wear protective oven mitts or gloves.

## Using accessories

Placing air flow racks into the unit:

1. Place the drip tray into the bottom of the unit.
2. Place the air flow racks in the unit by sliding through the side grooves and onto the back lip (fig. A).
3. For faster cooking and added crisp, place air flow racks closer to the top (fig. B).
4. Rotate the air flow racks mid-cycle for even cooking.

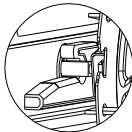

FIG.A

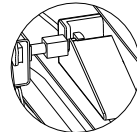

FIG.B

## Components



SKEWER RACK  
FRONTAL VIEW



ROTISSERIE SHAFT  
LEFT SIDE



RIGHT SIDE



SKEWERS  
(x10)



SET SCREWS  
(x2)

## Rotisserie shaft and skewer racks

1. Place two skewer racks on each end of the rotisserie shaft. Ensure the set screws are on the outer side of the shaft.
2. Slightly tighten set screws. Do not over tighten – you may need to adjust the tightness after you insert the skewers.

3. Carefully poke Skewers through food.

#### FINAL ASSEMBLY

#### FRONTAL VIEW

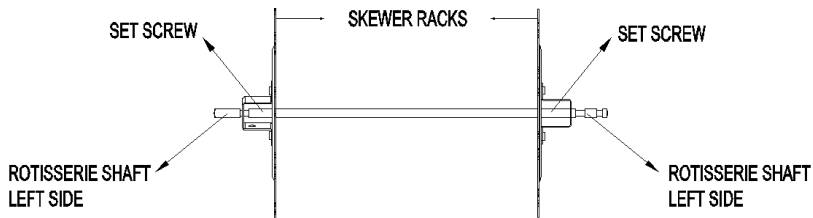

### Using the Accessories

#### Rotisserie Spit Assembly

1. Insert each skewer point through the holes on the skewer rack (fig. C).
2. Squeeze the clip end of each skewer as you insert into the opposite skewer rack slot to secure.
3. Release the clip to securely rest in slot as shown (fig. D).
4. Repeat steps 1-3 around the skewer rack. Ensure skewers are evenly spaced.
5. Tighten the set screws, ensuring they are securely in place.
6. Be cautious when inserting the spit into the unit to prevent getting poked by the skewer ends.

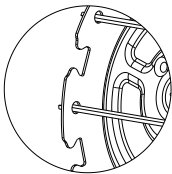
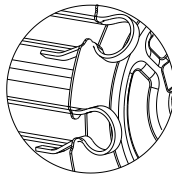

FIG. C-LEFT SIDE



FINAL ASSEMBLY

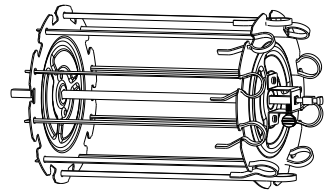

FIG. D-RIGHT SIDE

### Placing Rotisserie Spit or Rotating Mesh Basket into Unit

1. Insert the left side of the assembled spit or basket into the rotisserie shaft socket. Ensure the rotisserie shaft is in place for rotation (fig. E).
2. Place the right side onto the hanger (Fig. F).



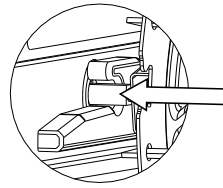
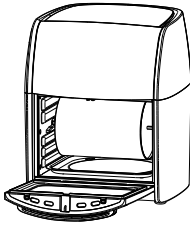

FIG.E- LEFT SIDE

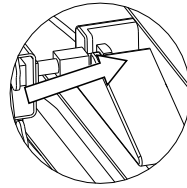

FIG.F-RIGHT SIDE

## IMPORTANT

See the final assembly diagram (page 5) to identify the left and right sides of the rotisseries shaft. The right side has two notches, the left has one.

### Removing rotisserie spit or rotating basket from unit

1. Open unit door to stop cooking – turn unit off by pressing power button.
2. Insert rotisserie fetch tool beneath the shaft.
3. Lift the right side of the fetch tool at a slight angle to clear the bracket.
4. Carefully remove the food from the oven.

### Using the Digital Control Panel

FIG.G

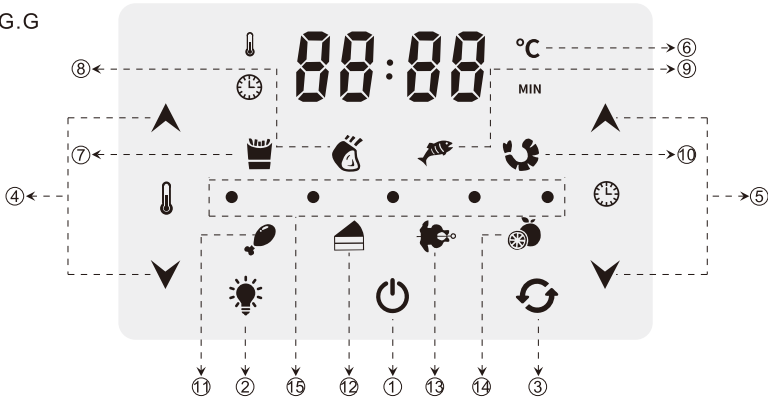

#### 1. Power button

When plugged in, the power button will light up. Holding the power button for two seconds will cause the full panel to be illuminated. Pressing the power button for a second time will start the cooking process at a default temperature of 185°C (185°F) – it will run for 15 minutes. When cooking, press the power button to pause the unit. Hold the power button for two seconds to shut down the unit. When you see the screen display 'OFF', the motor will stop working after 15 seconds – the machine will 'beep' three times.

## 2. Internal light

- Pressing this button lets you check on your food.

NOTE: Opening the door when cooking will pause the unit. Internal light will illuminate if doors open.

## 3. Rotation button

- Press this button when cooking anything using the rotisserie mode. Function can be used with any preset. The icon will blink while in use.

## 4. Temperature control

- Press these buttons to raise or lower cooking temperature by 5°C/°F, ranging from 65°C (150°F) to 200°C (400°F). Dehydration ranges from 30°C (90°F) to 80°C (175°F).

## 5. Time control

- These buttons let you choose your cooking time to the exact minute, from 1-60 minutes. All modes (except dehydrating, which uses 0.5hrs), intervals and operating times range from 2-24 hours.

## 6. LED digital display

- When cooking, the numeric display will switch between temperature and time remaining.

## 7-14. Cooking presets

- Selecting any of these will give you a default time and temperature for different foods. You can override these presets with the time and temperature buttons. View presets on the next page. Whilst in use, the function menu lets you switch your settings.

## 15. Running lights

These lights will blink in sequence when cooking. Once the unit is shut down, the lights will continue to blink for up to 15 seconds.

## Cooking Presets

### Preset cooking chart

\* Cooking time for a whole roasted chicken varies with weight. Use a meat thermometer to check internal temperature as per chart below.

PresetButton	Temperature	Time
7. FrenchFries	400°F (200°C)	15 mins
8. Steaks/Chops	370°F (185°C)	25 mins
9. Fish	390°F (200°C)	15 mins.
10. Shrimp	320°F (160°C)	12 mins.
11. Chicken	370°F (185°C)	40 mins
12. Baking	350°F (175°C)	30 mins
13. Rotisserie	400°F (200°C)	30 mins*
14. Dehydrator*	90°F (30°C)	4hrs(2-24hrs)

## Using the air oven without presets

Once you are familiar with the unit, you can experiment with your own time and temperature.

## Warning

Never use a cooking vessel filled with oil or other liquid with this unit. This could cause a fire hazard or personal injury.

## Internal temperature meat chart

Use this chart to check the internal temperature of cooked meats. REMINDER: This data should only be used as reference.

Food	Type	Internal Temperature
Beef & Veal	Ground	160°F (70°C)
	Steaks, roasts: medium	160°F (70°C)
	roasts: rare	145°F (63°C)
Chicken & Turkey	Breasts	165°F (75°C)
	Ground, stuffed	165°F (75°C)
	Whole bird, legs, thighs, wings	165°F (75°C)
Fish & Shellfish	Any type	145°F (63°C)
Lamb	Ground	160°F (70°C)
	Steaks, roasts: medium	160°F (70°C)
	Steaks, roasts: rare	145°F (63°C)
Pork	Chops, ground, ribs, roasts	160°F (70°C)
	Fully cooked ham	140°F (60°C)

## General operating instructions

### Before using for the first time:

1. Read all instructions, warning stickers and labels.
2. Remove all packaging, labels and stickers.
3. Wash all parts and accessories with warm, soapy water. NOTE: Only accessories can be used in a dishwasher.
4. Using a clean and damp cloth, wipe the inside and outside of the unit.

**NOTE:** Never wash or submerge this appliance in water.

**NOTE:** When using this unit, never fill with oil or any other liquid. This unit cooks with hot air only.

### Preparing for use

1. Place the appliance on a stable, level and heat-resistant surface.
2. Choose the cooking accessory for your recipe.

### A versatile appliance

This air oven can cook a variety of foods. The charts and table are a guide for the best results. Refer to this information for time/temperature settings and proper food quantities.

## Warning

- Never put anything on top of the appliance.
- Never cover the air vents on the top and back of the unit.
- Never place the basket filled with food on the oven door. The basket could damage the door or cause the unit to tip, resulting in personal injury.
- Always use oven mitts when removing the racks.

## **General operating instructions**

### **Cooking with the air oven**

1. Place the ingredients on an air flow rack, on one of the rotisserie accessories or in the rotating mesh basket.
2. Put the air flow rack, rotating mesh basket or rotisserie spit into the unit – shut the oven door. Plug the power cord into the socket (the power provided must adhere to the rated power of the product).
3. When the basket or rotisserie and food is in place, press the power button once (page 6, fig. G1).
4. Select a preset function (page 6, Fig G7-14) or manually set the temperature and time (page 6, Fig. G4-5). Refer to the control panel instructions on page 6.
5. Once you have selected a function, the unit will automatically start cooking after a few seconds. You can also press the power button to start cooking immediately, once your desired time and temperature has been selected.

**NOTE:** You can open the oven door to check the cooking progress.

**NOTE:** To ensure you have the correct settings, check a recipe book or the charts in this manual.

### **Tips**

- Smaller foods require a shorter cooking time.
- Large quantities of food require a longer cooking time.
- Flip smaller sized foods halfway through cooking, ensuring all pieces are evenly fried.
- Adding a bit of vegetable oil on fresh potatoes is suggested for a crispier result. Add the oil just before cooking.
- Snacks normally cooked in an oven can be cooked in the air oven.
- Use premade dough to prepare filled snacks quickly and easily. Premade dough requires shorter cooking time.
- When baking a cake or quiche, place a baking tin or oven dish in the air oven. It is suggested to use a tin or dish for cooking fragile or filled foods.
- You can use the air oven to reheat foods. Set the temperature to 150°C (300°F) for up to 10 minutes.

### **Important**

#### **Removing cooked or hot food**

When removing cooked or hot food, use the fetch tool (Fig. H) or use oven mitts. The fetch tool can also be used with the rotisserie spit.

FIG.H



## Warning

- When cooking, the basket and other accessories will become very hot. When removing, ensure you have a trivet or a heat-resistant surface nearby to set it down. Never place the rotating mesh basket directly on a counter top or table.
- Cooking accessories will get hot during the air frying process. Wear oven mitts and handle with care to avoid injury.

## Cooking Chart

Food Item	Min- Max	Time	Temperature	Comments
Thin Frozen Fries	1 ¼-3 cups	15-16mins	400°F(200°C)	
Thick Frozen Fries	1 ¼-3 cups	15-20 mins	400°F(200°C)	
Homemade Fries	1 ¼-3 ¼ cups	10-16mins	400°F(200°C)	Add ½ tbspoil
Homemade Potato Wedges	1 ¼-3 ¼ cups	18-22 mins	360°F(182°C)	Add ½ tbspoil
Homemade Potato Cubes	1 ¼-3 cups	12-18mins	360°F(182°C)	Add ½ tbspoil
Hash Browns	1 cup	15-18mins	360°F(182°C)	
Potato Gratin	2 cup	15-18mins	400°F(200°C)	
Steak	¼-1.1lb(500g)	8-12 mins	360°F(182°C)	
Pork Chops	¼-1.1lb(500g)	10-14mins	360°F(182°C)	
Hamburger	¼-1.1lb(500g)	7-14 mins	360°F(182°C)	
Sausage Roll	¼-1.1lb(500g)	13-15mins	400°F(200°C)	
Chicken Drumsticks	¼-1.1lb(500g)	18-22mins	360°F(182°C)	
Chicken Breast	¼-1.1lb(500g)	10-15mins	360°F(182°C)	
Spring Rolls	¼- ¾ lb(350g)	15-20mins	400°F(200°C)	Use oven-ready
Frozen Chicken Nuggets	¼-1.1lb(500g)	10-15mins	400°F(200°C)	Use oven-ready
Frozen Fish Sticks	¼-1.1lb(500g)	6-10 mins	400°F(200°C)	Use oven-ready
Mozzarella Sticks	¼-1.1lb(500g)	8-10 mins	360°F(182°C)	Use oven-ready
Stuffed Vegetables	¼-1.1lb(500g)	10 mins	320°F(160°C)	
Cake	1 ¼ cups	20-25mins.	320°F(160°C)	Use baking tin
Quiche	1 ½ cups	20-22mins.	360°F(182°C)	Use baking tin/ovendish
Muffins	1 ¼ cups	15-18mins	400°F(200°C)	Use baking tin
Sweet Snacks	1 ½ cups	20 mins	320°F(160°C)	Use baking in/ovendish
Frozen Onion Rings	1 lb(450g)	15 mins	400°F(200°C)	

## Cooking chart

### Settings

This table (page 10) can help you select the time and temperature for the best results. As you become familiar with the appliance, you can adjust these setting to suit your personal taste.

**NOTE:** Keep in mind that these settings are for reference only. Since ingredients differ in origin, size, shape and brand, we cannot guarantee the best settings for your ingredients.

## Tips

- Set the timer, so the machine can alert you when it is time to flip your food. When you hear the bell, the preset preparation time is up.
- Add three minutes to your cooking time if the appliance is cold.

## Cleaning and storage

### Cleaning

- Clean the air oven after each use.
  - The basket and other accessories are made of stainless steel – they can be used in the dishwasher. Never use abrasive cleaning materials or utensils on these surfaces. Caked-on food should be soaked in warm, soapy water for easy removal.
  - Before cleaning, unplug the appliance and ensure it has fully cooled down.
1. Wipe the outside of the appliance with warm, soapy water, using a damp cloth and mild detergent.
  2. To clean the oven door, remove it by lifting to an 80 ° angle, while gently pulling upward.  
Clean both sides with warm, soapy water and a damp cloth. Do not soak or submerge the door in water. Do not put the door into the dishwasher.
  3. Clean the inside of the appliance with hot water, mild detergent and a non-abrasive sponge.
  4. If necessary, remove food residue from the upper screen with a cleaning brush.

### Storage

1. Unplug the appliance and let it cool thoroughly.
2. Ensure all components are clean and dry.
3. Place the appliance in a clean and dry place.

## Troubleshooting

Problem	Possible Cause	Solution
The unit does not work	<ol style="list-style-type: none"><li>1. The appliance is not plugged in.</li><li>2. You have not set the preparation time and temperature.</li></ol>	<ol style="list-style-type: none"><li>1. Plug the power cord into a wall socket.</li><li>2. With the basket in place, set the set the temperature and time. Ensure the door is properly closed.</li></ol>
Food not cooked	<ol style="list-style-type: none"><li>1. The rotating mesh basket is too full.</li><li>2. The temperature is set too low.</li></ol>	<ol style="list-style-type: none"><li>1. Use smaller batches of food for more even frying.</li><li>2. Raise the temperature and continue cooking.</li></ol>
Food is not evenly fried.	Some food needs to be turned when cooking.	See 'General operations' on page 8.
White smoke coming from the appliance.	<ol style="list-style-type: none"><li>1. Oil is being used.</li><li>2. Accessories have excess grease from previous cooking.</li></ol>	<ol style="list-style-type: none"><li>1. Wipe to remove excess oil.</li><li>2. Clean the rotating mesh basket after each use.</li></ol>

French fries are not fried evenly	1. Wrong type of potato being used. 2. Potatoes are not rinsed properly during preparation	1. Use fresh, firm potatoes. 2. Use cut sticks and pat dry to remove excess starch.
Fries are not crispy	Raw fries have too much water.	Dry potato sticks properly before misting oil. Cut sticks smaller, add a bit more oil.
Door came off	Door came off the hinge.	As the door is slightly open (about 1 in. /2.5 cm from the closed position), align the hinge so the joints fall into the slots. Then, close the door.

## Error Codes

Display Shown	Possible Cause	Solution
E1	Broken circuit of the thermal sensor	Call Customer Service
E2	Short circuit of the thermal sensor	Call Customer Service

## Frequently Asked Questions

### 1. Can I prepare foods other than fried dishes with my Air Oven?

You can prepare a variety of dishes, including steaks, chops, burgers, and baked goods. See the Air Oven Recipe Guide.

### 2. Is the Air Oven good for making or reheating soups and sauces?

Never cook or reheat liquids in the Air Oven.

### 3. What do I do if the Unit shuts down while cooking?

As a safety feature, the Air Oven has an Auto Shut-Off device that prevents damage from overheating. Unplug and allow the Unit to cool down. Plug back in and restart with the Power Button.

### 4. Does the Unit need time to heat up?

Preheating is needed when you are cooking from a cold start, add 3 mins. to the cook time to compensate.

### 5. Is it possible to shut off the Unit at any time?

Press the Power Button once or open the door.

### 6. Can I check the food during the cooking process?

You can remove the Rotating Mesh Basket at any time while cooking is in progress. During this time, you can flip the contents on the Air Flow Racks if needed to ensure even cooking. Time and temperature will resume where you left off.

### 7. Is the Air Oven dishwasher safe?

Only the accessories are dishwasher safe.

The Unit itself containing the heating coil and electronics should never be submersed in liquid of any kind or cleaned with anything more than a hot, moist cloth or nonabrasive sponge with a small amount of mild detergent.

### 8. What happens if the Unit still does not work after I have tried all the troubleshooting suggestions?

Never attempt a home repair.

Contact the manufacturer and follow the procedures set forth by the warranty. Failure to do so could render your warranty null and void.

### 9. Can the door come off?

Yes, it can. Open the door slightly (about 1 in./2.5 cm from the closed position), and gently lift up on the door hinge. The joints will slide out. You may clean the unit and windows more easily. To put the door back on, have the door slightly open as before, then align the hinge, so the joints all into the slots. Then, close the door.

