



1. Suitable age for 18-36 Months.
2. Maximum user weight: 20KGS.
3. Adult assembly required



IMPORTANT, RETAIN FOR FUTURE REFERENCE: READ CAREFULLY

About Your New Vehicle

Specification	Item	Specifications
Maximum weight	Size	20KGS 73*39*48CM
Available ages		Children at 18-36 months

WARNING:

- (1). this kind of product is fit for the children aged 18-36 month old and maximum load under 20kg maximum load under 20kg
- (2).WARNING-never leave the child unattended
- (3).prevent access to stairs, steps and uneven surface
- (4). remove hot liquids, electrical flexes and other potential hazards from reach
- (5).prevent collisions with glass in doors,windows and furniture
- (6).instrution for rountine maintenance and cleaning or washing
- (7). before using, this product will be inspected and assembled by the adult

The notices of installing and changing batteries

- (1). installing and changing batteries should be fulfilled by adults
- (2).install the battries refer to the picturs(1) of the parts:
the installation of AAA(1.5V) batteries: open the cover, install the battries correctly according to the marks of the postive and the negative erectrodes , finally put on the cover and fasten the cover

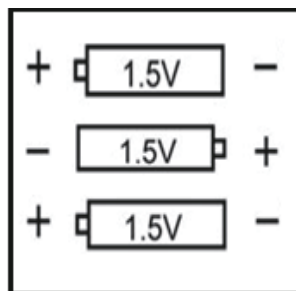

- (3).the unchargable battries must not be changed and do not mix the different types of the battries(or the new and the old) to use together
- (4).take out the used-up batteries and avoid short circuit.



1.Body



4.Front mud plate



7.Front wheel



2.Windshield



5.Handlebar



8.Rear wheel



3.Fork



6.A rear axle



9.Garnish

A x 8



M10

B x 1



M5*30

C x 4



M8

D x 1



M5

Note:

All screws, nuts and small plastic parts are pre-installed in the corresponding position, please follow the steps to remove before you install the product.

INSTALLATION STEPS

Step 1 Install the rear wheel



As shown in the arrow, insert the shaft frame into the car body, pass the gasket, rear wheel, gasket and nut (as shown in Figure 1) through the axle, and tighten the nut clockwise (as shown in Figure 2).

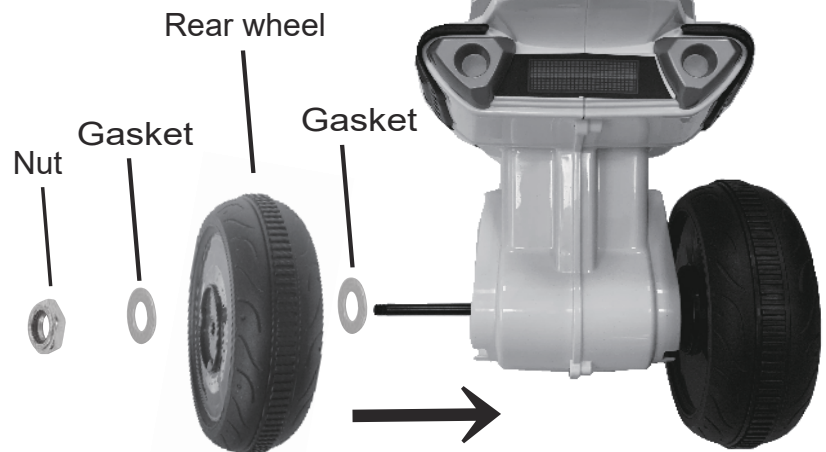
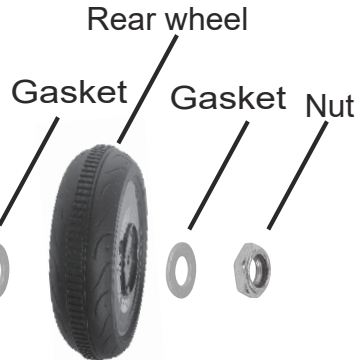

Installing the other side wheel is the same as step 1.

Step 2 Install front wheel

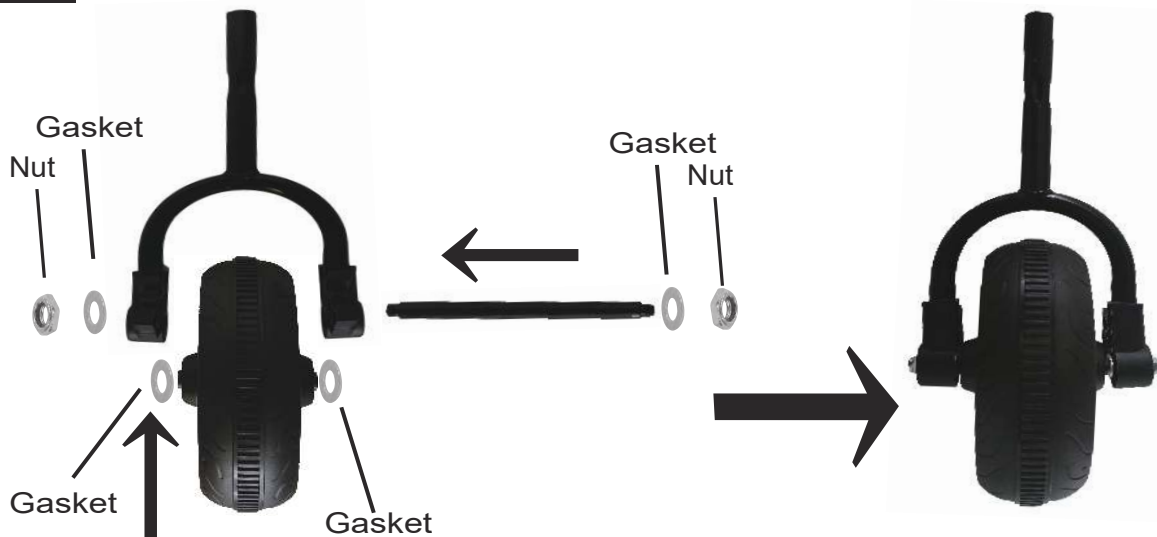

As shown in the arrow, insert the shaft into the front fork, pass through the gasket X2, the front wheel, the gasket X2 and the nut (as shown in the figure), and tighten the nut clockwise

Step 3 Install mudguard

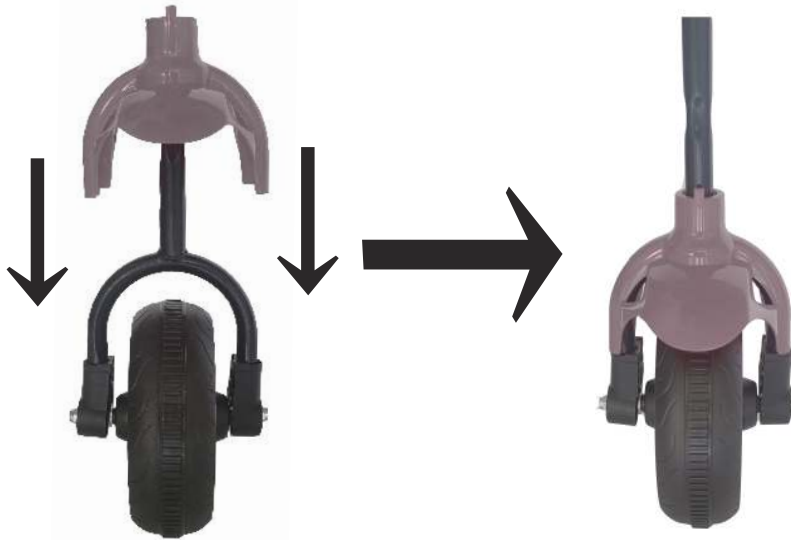

Insert Front mud plate onto the fork

Step 4 Install the Fork

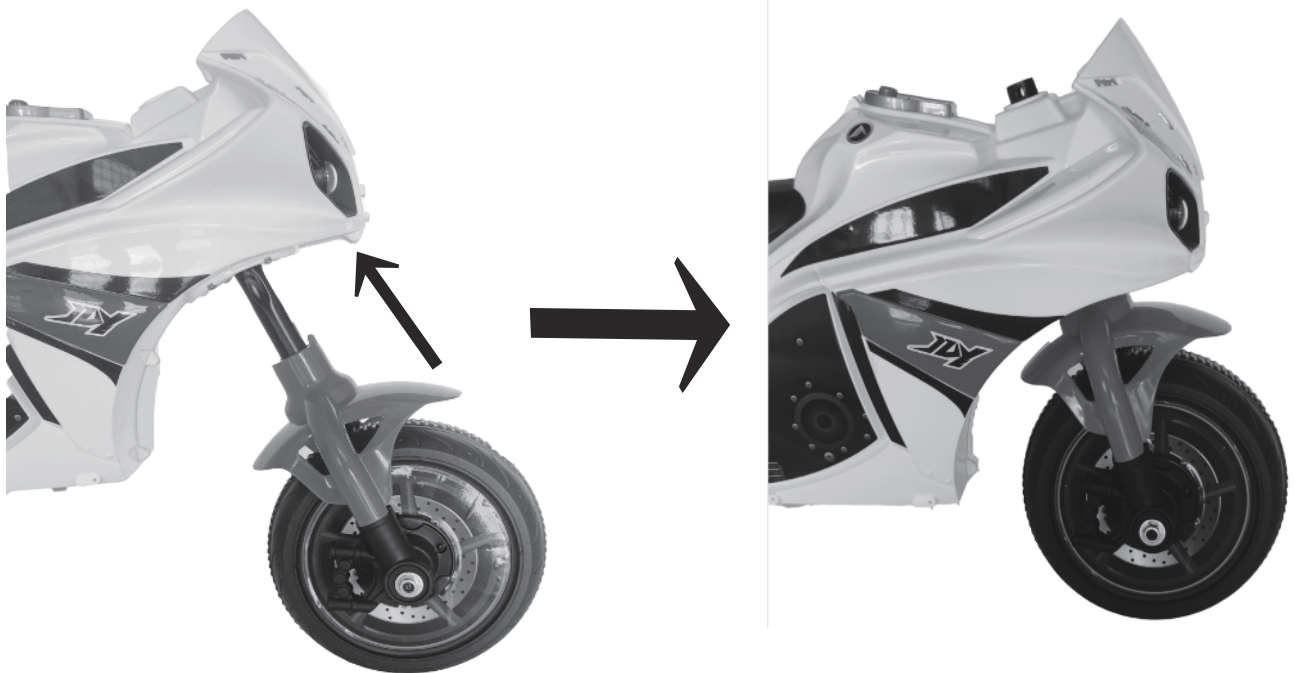

Insert the front fork into the car body and press tight

Step 5 Install the Handlerbar



fix the handle bar & tap sleeve
(1X(5X30)Screw & 1XM5 Nut)

Step 6 Install the Windshield



Stuck the windshield on Body

Step 7 Install the battery

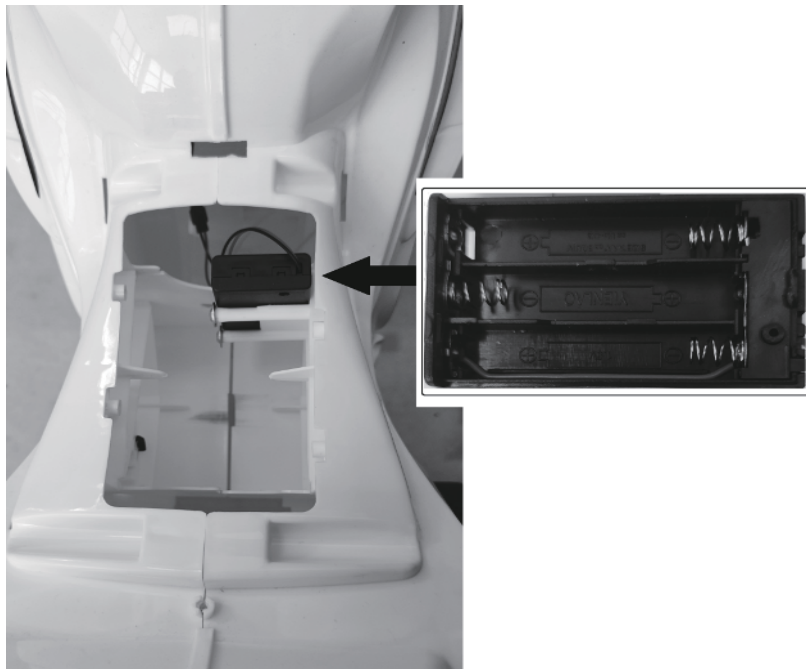

Loosen the 4x10 mounting screws and open the seat cushion to see the battery box. Add the dry battery and you can use the music function.

box and take off the cover;

Use three AAA 1.5V cells, please install the batteries properly.

Warning:

Do not mix to use the batteries, such as used, unused, different type, etc.

Keep the child away from the battery.

UK

If you have any questions, please contact our customer care center.

Our contact details are below:



0044-800-240-4004



enquiries@mhstar.co.uk

IMPORTER ADDRESS:

MH STAR UK LTD

Unit 27, Perivale Park,

Horsenden lane South

Perivale, UB6 7RH

MADE IN CHINA

