

HOMCOM

IN221000644V01_UK

824-012V70

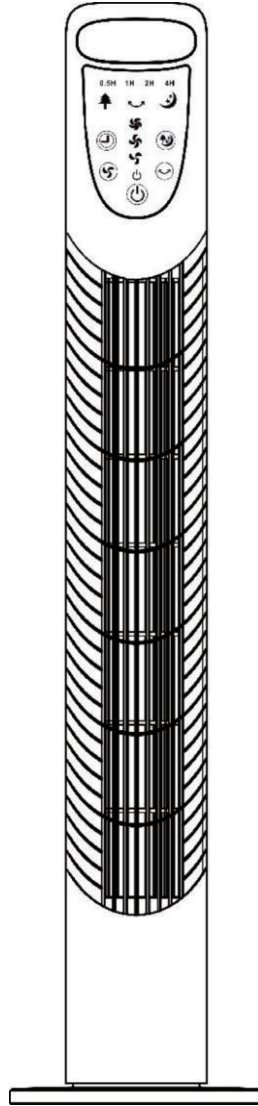

Mist Fan, 16 Inch 220V-240V,50Hz, 90W

UK
CA CE

EN_IMPORTANT, RETAIN FOR FUTURE REFERENCE: READ CAREFULLY.

FR_IMPORTANT: A LIRE ATTENTIVEMENT ET À CONSERVER POUR CONSULTATION ULTÉRIEURE.

ES_IMPORTANTE, LEA Y GUARDE PARA FUTURAS REFERENCIAS.

PT_IMPORTANTE, RETER PARA REFERÊNCIA FUTURA: LEIA ATENTAMENTE.

DE_WICHTIG! SORGFÄLTIG LESEN UND FÜR SPÄTER NACHSCHLAGEN AUFBEWAHREN.

IT_IMPORTANTE! CONSERVARE IL PRESENTE MANUALE PER FUTURO RIFERIMENTO E LEGGERLO ATTENTAMENTE.

EN

Dear customer,

Thank you for purchasing this product. So that your appliance serves you well, please read all the instructions in this user's manual. If you have any questions, please contact our customer care center, Our contact details are below:

FR

Cher client,

Nous vous remercions d'avoir acheté ce produit. Afin que vous puissiez profiter pleinement de votre appareil, veuillez lire toutes les instructions de ce manuel d'utilisation. Si vous avez la moindre question, veuillez contacter notre centre d'assistance à la clientèle, Nos coordonnées sont les suivantes:

DE

Sehr geehrter Kunde,

Vielen Dank, dass Sie dieses Produkt erworben haben. Damit Ihr Gerät Ihnen gute Dienste leistet, lesen Sie bitte alle Hinweise in diesem Benutzerhandbuch. Wenn Sie Fragen haben, wenden Sie sich bitte an unser Kundendienstzentrum, Unsere Kontaktdaten stehen unten:

ES

Queridos clientes,

Gracias por comprar este producto. Para que su electrodoméstico le sirva mejor, lea todas las instrucciones de este manual del usuario. Si tiene alguna pregunta, comuníquese con nuestro Centro de Atención al Cliente, Nuestros datos de contacto son los siguientes:

PT

Caros clientes,

Obrigado por adquirir este produto. Para que o seu aparelho o sirva melhor, leia todas as instruções deste manual do utilizador. Se tiver alguma dúvida, por favor contacte o nosso Centro de Atendimento ao Cliente, Os nossos dados de contacto são os seguintes:

IT

Caro Cliente,

Grazie per aver acquistato questo prodotto. Per servirti meglio con questo apparecchio ti prego di leggere tutte le istruzioni in presente manuale utente. In caso di dubbio, si prega di contattare il nostro centro assistenza clienti, I nostri dettagli di contatto sono di seguito:

Country	 Phone	 Email
US	001-877-644-9366	customerservice@aosom.com
CA	416-792-6088	customerservice@aosom.ca
UK	0044-800-240-4004	enquiries@mhstar.co.uk
DE	0049-0(40)-88307530	service@aosom.de
FR	0033-1-84166106	aosom@mhfrance.fr
ES&PT	0034-931294512	atencioncliente@aosom.es
IT	0039-0249471447	clienti@aosom.it



When using electric devices, basic safety precautions must be observed. To avoid the risk of burns, electric shocks, fire, and/or personal injury, please read the instruction manual carefully before using the device, and observe all of the instructions during the operation of the device.



GENERAL GUIDELINES

- Electronic devices are not toys! Keep children away from the device!
- Only use the devices for its intended purpose.
- The device is only suitable for use in private households and not for commercial use.
- Do not leave the device unsupervised while in use or connected to the mains.
- Switch off the device if it is not in use, in the event of malfunctions and for cleaning, and also remove the power plug.
- Do not carry the device by the power cord.
- Keep the device clean and dust-free.
- Never use the device outdoors.
- Check the device regularly for signs of visible damage. Do not use the device if you have determined damage, if the device has fallen down or if it does not function properly. Do not attempt to repair the device yourself.
- Repairs are only allowed to be carried out by qualified specialists.
- The power point must be located near to the device so that the plug can be removed easily in an emergency.



HAZARDS DUE TO ELECTRIC CURRENT

- The voltage stated on the name plate of the device must agree with the voltage of your mains electricity network.
- Only connect the device to a power socket that has been installed properly. Do not use a power strip or an extension cable.
- Never operate the device using a timer or another remote control device.

- Never touch the device, the power cable and the plug with damp or wet hands or if you are standing on wet ground.
- Do not place the power cord in the sink.
- Do not immerse in water.
- Immersing the device in water or other fluids leads to a risk to life of electric shock!
- Keep the device, the power cable and plug away from hot surfaces, naked flames, direct sunlight and sharp edges. When using the device make sure that the cable is not jammed (e.g. in doors).
- When you pull the plug out of the power socket, always pull on the plug and never on the cable.
- If the power cable of this device is damaged it has to be replaced by a correspondingly qualified person to prevent hazards. The same applies to the plug.



HAZARDS TO PEOPLE

- These devices can be used by children aged 8 years and above and by people with reduced physical, sensory or mental capabilities or a lack of experience and/or knowledge, if they are supervised or instructed in the safe use of the product and understand the hazards involved. Children must not play with the appliance.
- Cleaning and maintenance of the product must not be performed by children.
 - Children do not recognise the hazards which can arise when handling electrical devices. Keep children away from the device. Pay particular attention when using the device if children are in the vicinity!
 - Keep the packaging materials such as plastic bags and polystyrene parts out of the reach of children. Danger of suffocation!
 - When laying the cable make sure that it cannot become a tripping hazard.
 - Make sure that the device itself cannot be tripped over.

ARTICLE-SPECIFIC HAZARDS

- Make sure that the device isn't dirty and that it is assembled correctly
- Never operate the appliance on uneven surfaces or in the vicinity of steps. Avoid tipping the device over when it is in use (e.g. if there are borders on the floor).
- The pedestal fan may only be used, if it is fully assembled. Check all screw / plug connections at regular intervals. Retighten loose screws and ensure that plug connections are properly adjusted.

OVERVIEW OF APPLIANCE

1. Air outlet grating
2. Holder
3. Time
4. Speed
5. Mode
6. Oscillation
7. ON/OFF
8. Power plug
9. Stand
10. Screws
11. Remote control

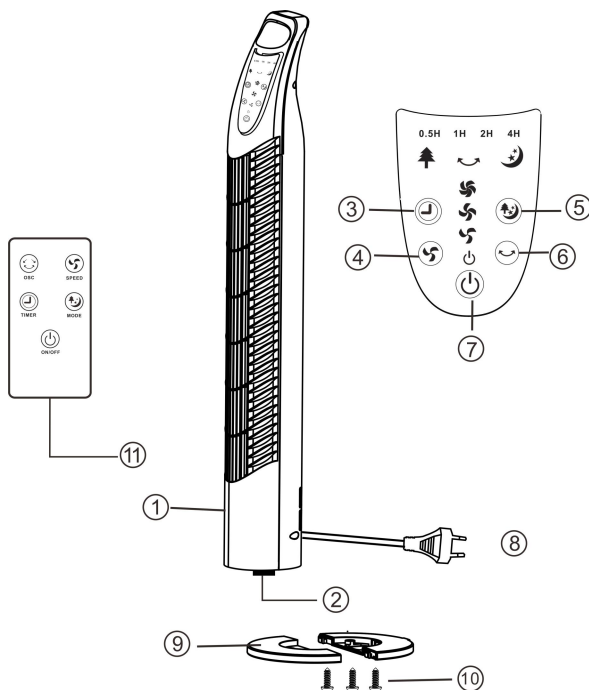

ASSEMBLING THE STAND

1. Take all of the appliance parts out of the packaging and remove all packaging materials and inserts.
2. Turn the fan upside down so that you can look at the *holder* (2). (Fig.1).
3. Put the part.1 (Fig.2) of the *stand* (9) , and use 1 piece of screw to tight up, see the methods by (Fig.3).

4. Take the power cord to cross the part.2 (Fig.2) stand (9), and press it into the outlet hole.

5. Put the part.2 of the stand(9), (Fig.2), and press it into the part.1 (Fig.2) ,use 2 pieces of screw to tight up, see the methods by (Fig.4).

Fig. 1:

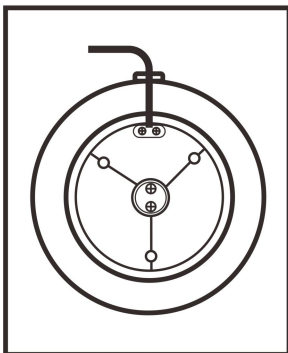

Fig. 2:

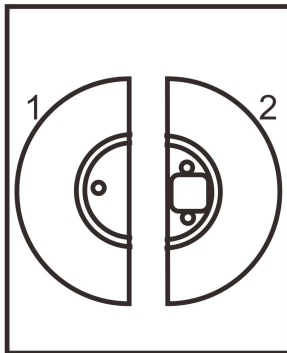

Fig. 3:

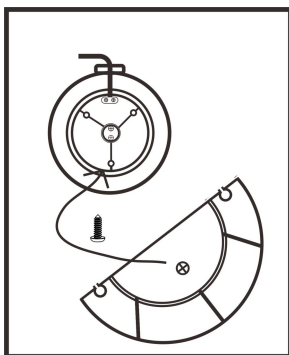
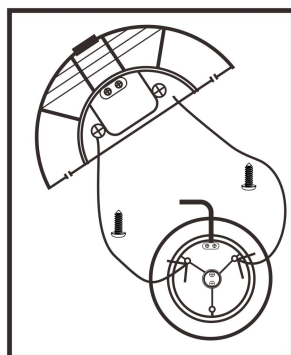

Fig. 4:



HANDLING THE APPLIANCE

POWER

- Press the button of ON/OFF (7), to select power on / off the appliance.

SPEED

- Press the button of ON/OFF (7) , to power on the appliance.
- Press the button of Speed (4), to select the fan speed.
- 3 speed for select: (Low - Mid - High)

MODE

- Press the button of ON/OFF (7) , to power on the appliance.
- Press the button of MODE (5), to select the fan mode.
- 3 mode for select: (NORMAL / NATURE / SLEEP).
- The default mode is NORMAL, and the SLEEP/NATURE mode with the indicator be light up.

TIMER (0.5 - 7.5 HOURS)

- Press the button of ON/OFF (7) , to power on the appliance.
- Press the button of TIMER (3) to the desired time period (0.5-7.5 Hours)
- It will now remain in operation until the selected period of time runs out.
- After the timer runs over , the device will turn off.

OSCILLATION

- Press the button of ON/OFF (7) , to power on the appliance.
- Press the button of OSCILLATION (6), appliance will swing from Left to Right.

REMOTE CONTROL

- All the function above can be setting by remote control

CLEANING AND MAINTENANCE

Before cleaning the appliance always disconnect the power plug from the receptacle.

- The appliance, the power cord and the power plug should not be immersed in water or other liquids when you are cleaning them. Clean them with a dry cloth.
- If it is very dirty, the outside of the appliance can be wiped carefully with a moist cloth and then dried carefully. Make sure that no moisture penetrates into the interior of the appliance.
- Do not use any harsh cleaners, steel brushes, scouring powder or other hard objects to clean the appliance as these can cause scratches on the surfaces.
- Clean the appliance regularly.
- Never use solvents, benzene or oil-based cleaners as these can damage the housing.
- Re-tighten visible screw connections on the appliance regularly in order to ensure that the device is functioning properly.

DISPOSAL



Used electric household devices

1. If you do not want to use your electrical appliance any longer, return it free of charge to a recycling depot for used electric appliances.
2. Used electric devices do not belong in the household garbage (see symbol).

Further disposal instructions

1. Return the electrical appliance in such a condition that its later re-use or recycling is not adversely affected. Batteries must be removed in advance and the destruction of parts which contain fluids must be avoided.
2. Electrical appliances can contain harmful substances. Improper handling or damage to the appliance can lead to health problems or water or ground contamination, when the appliance is recycled later.

SPECIFICATION

PRODUCT: TOWER FAN

MODEL: 824-012V70BK/012V90/012V70S

POWER:40W

VOLTAGE: 220-240V~ 50Hz



Made In China

All images serve as illustrations only and do not always show exact representations of the device.

All rights reserved.

US

Imported by Aosom LLC
27150 SW Kinsman Rd Wilsonville, OR 97070 USA
Manufactured in Ningbo City, Zhejiang Province, China
MADE IN CHINA

CA

Imported by Aosom Canada Inc.
1251 Tapscott Road, Unit 101, Scarborough, Ontario Canada M1X 1S9
Manufactured in Ningbo City, Zhejiang Province, China
MADE IN CHINA

Importé par Aosom Canada Inc.
1251 Rue Tapscott, Unité 101, Scarborough, Ontario Canada M1X 1S9
Fabriqué à Ville de Ningbo, Province du Zhejiang, Chine
FABRIQUÉ EN CHINE

UK

IMPORTER ADDRESS:
MH STAR UK LTD
Unit 27, Perivale Park,
Horsenden lane South
Perivale, UB6 7RH
MADE IN CHINA

FR

ADRESSE D'IMPORTATION:
MH FRANCE
2 Rue Maurice Hartmann
92130 Issy Les Moulineaux
France
FABRIQUÉ EN CHINE

ES

IMPORTADOR:
SPANISH AOSOM, S.L.
C/ROC GROS,Nº15.08550, ELS HOSTALET DE BALENYÀ, SPAIN.
B66295775
WWW.AOSOM.ES
ATENCIONCLIENTE@AOSOM.ES
TEL: 931294512
HECHO EN CHINA

DE

ADRESSE DES IMPORTEURE:
MH Handel GmbH
Wendenstraße 309
D-20537 Hamburg
Germany
IN CHINA HERGESTELLT

IT

IMPORTATO DA:
AOSOM Italy srl
Centro Direzionale Milanofiori
Strada 1 Palazzo F1
20057 Assago (MI)
P.I.: 08567220960
FATTO IN CINA