

**UK
CA**

CE

EN_IMPORTANT, RETAIN FOR FUTURE REFERENCE: READ CAREFULLY.

FR_IMPORTANT: A LIRE ATTENTIVEMENT ET À CONSERVER POUR CONSULTATION ULTÉRIEURE.

ES_IMPORTANTE, LEA Y GUARDE PARA FUTURAS REFERENCIAS.

PT_IMPORTANTE, RETER PARA REFERÊNCIA FUTURA: LEIA ATENTAMENTE.

DE_WICHTIG! SORGFÄLTIG LESEN UND FÜR SPÄTER NACHSCHLAGEN AUFBEWAHREN.

IT_IMPORTANTE! CONSERVARE IL PRESENTE MANUALE PER FUTURO RIFERIMENTO E LEGGERLO ATTENTAMENTE.



EN:WARNING:

Check all the parts are well connected before use.

Regularly check and maintain the main components (suspenders, fasteners, fixings, etc.), otherwise the swing may tip over or cause a fall.

Never leave your child unattended. Use under adult supervision.

Age for 3-8 years.

Maximum loading weight: 40kgs/seat

DE:WARNUNG:

Überprüfen Sie vor dem Gebrauch, ob alle Teile richtig angeschlossen sind.

Überprüfen und warten Sie regelmäßig die Hauptkomponenten (Hosenträger, Befestigungselemente, Befestigungen usw.), da sonst die Schaukel umkippen oder einen Sturz verursachen kann.

Lassen Sie Ihr Kind niemals unbeaufsichtigt. Verwendung unter Aufsicht von Erwachsenen.

Alter für 3-8 Jahre

Maximales Ladegewicht: 40 kg/Sitz

FR:ATTENTION:

Vérifiez que toutes les pièces sont bien connectées avant utilisation.

Vérifiez et entretenez régulièrement les principaux composants (bretelles, attaches, fixations, etc.), sinon la balançoire pourrait basculer ou provoquer une chute.

Ne laissez jamais votre enfant sans surveillance. Utiliser sous la surveillance d'un adulte.

Âge de 3 à 8 ans

Poids de chargement maximum: 40kgs/siège

IT:ATTENZIONE:

Verificare che tutte le parti siano ben collegate prima dell'uso.

Controllare e mantenere regolarmente i componenti principali (bretelle, elementi di fissaggio, fissaggi, ecc.), Altrimenti l'oscillazione potrebbe ribaltarsi o causare una caduta.

Non lasciare mai tuo figlio incustodito. Utilizzare sotto la supervisione di un adulto.

Età per 3-8 anni

Peso massimo di carico: 40 kg/posto

ES:ADVERTENCIAS:

Compruebe que todas las piezas estén bien conectadas antes de su uso.

Revise y mantenga regularmente los componentes principales (tirantes, sujetadores, fijaciones, etc.), de lo contrario, el columpio puede volcarse o provocar una caída.

Nunca deje a su hijo sin supervisión. Usar bajo la supervisión de un adulto.

Edad de 3 a 8 años

Peso máximo de carga: 40kgs/asiento

①×1	②×1	G×1 ø5	F×1 ø4	I×1 ø10,ø13
③×1	④×2			
⑤×2	⑥×2	⑦×2	⑧×2	
E1×4 ø6×47	E2×4 ø6×52	E3×4 ø6×55	E4×4 ø6×94	E5×1 ø8×65
H1×16 ø6	H2×1 ø8	H3×12 ø6	K×2	

E3	x4
H1	x4
H3	x4

01

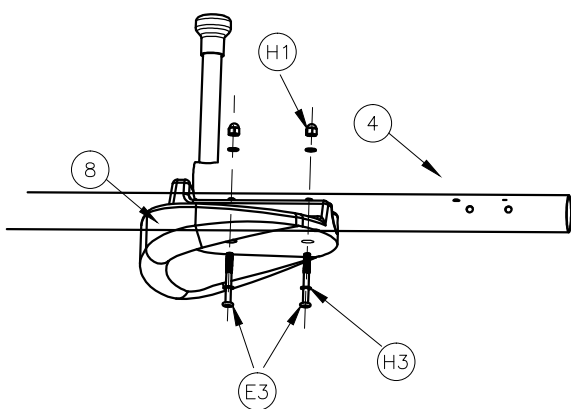

E2	x4
H1	x4
H3	x4

02

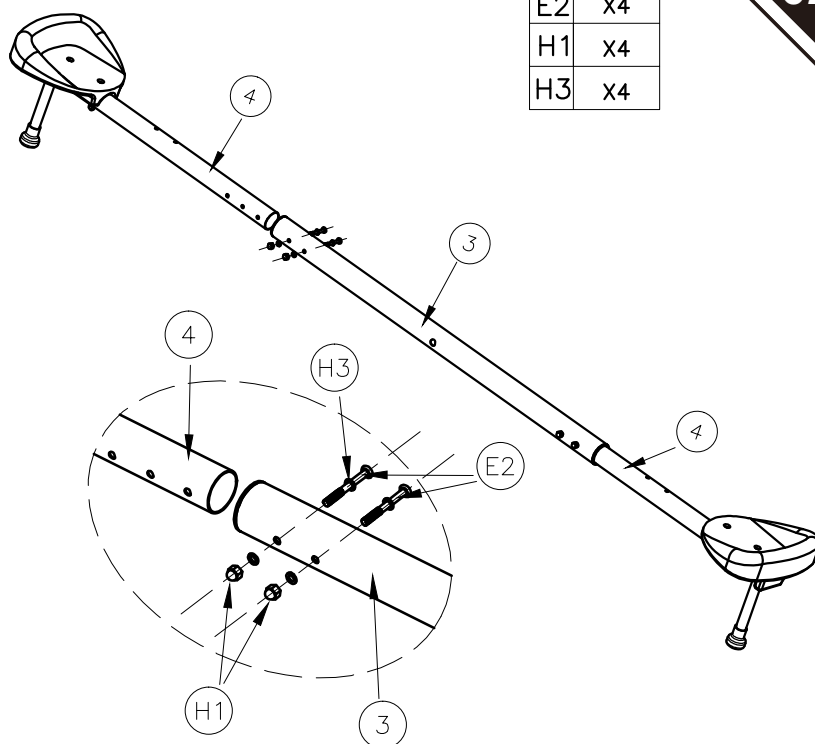

E1	x4
H1	x4

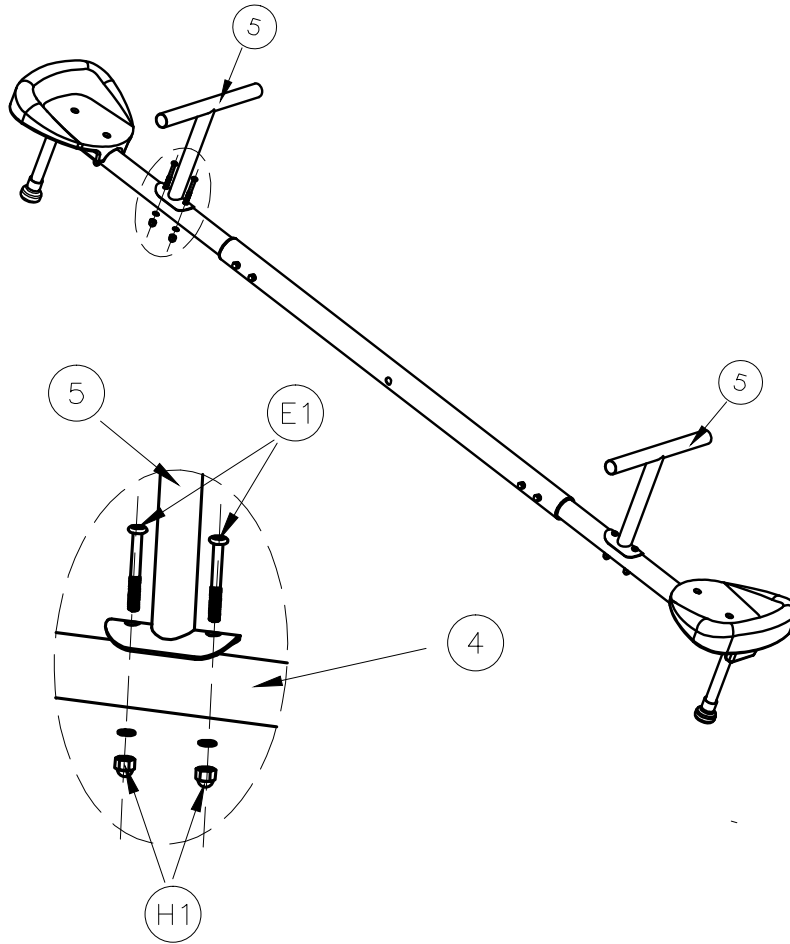

K	x2
E5	x1
H2	x1

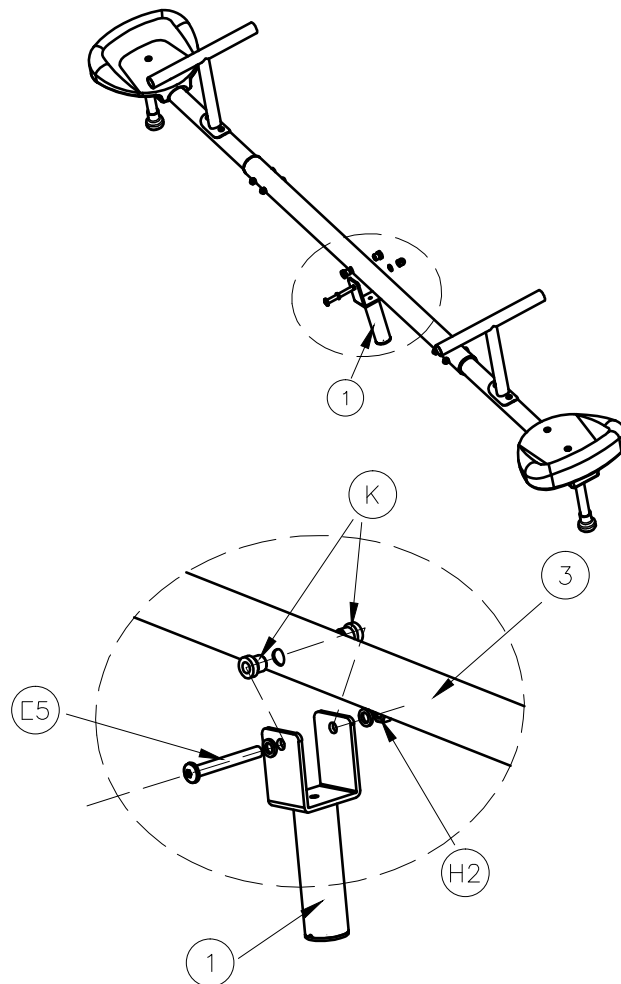

E4	x4
H1	x4
H3	x4

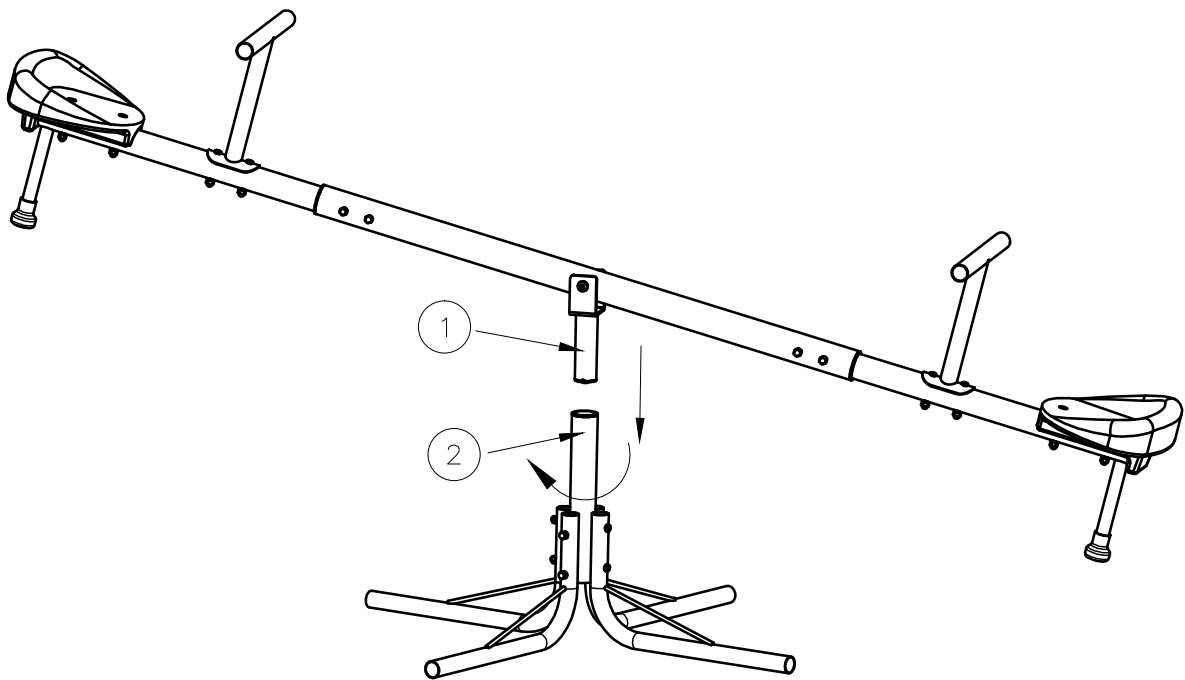
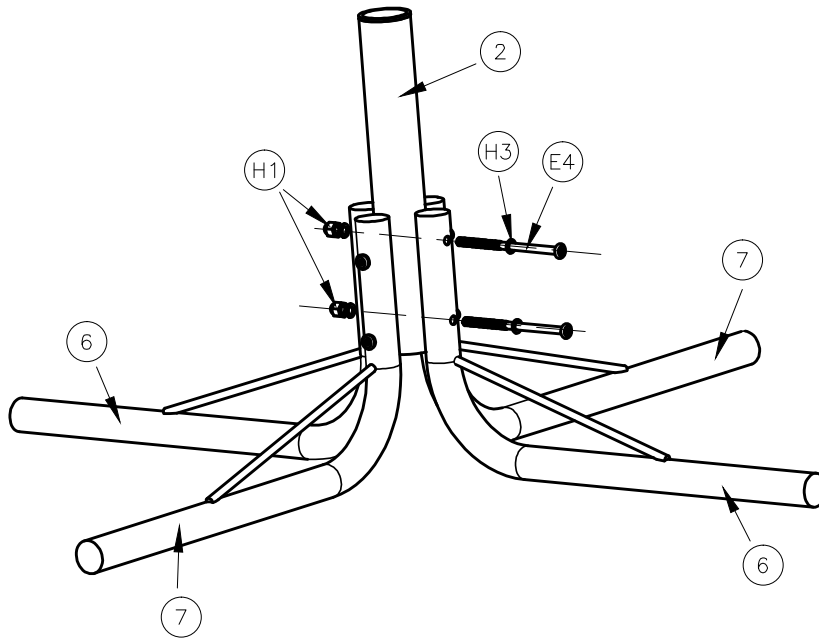

UK

If you have any questions, please contact our customer care center.

Our contact details are below:



0044-800-240-4004



enquiries@mhstar.co.uk

IMPORTER ADDRESS:

MH STAR UK LTD

Unit 27, Perivale Park,
Horsenden lane South

Perivale, UB6 7RH

MADE IN CHINA

ES

Si tiene alguna pregunta, comuníquese con nuestro Centro de Atención al Cliente. Nuestros datos de contacto son los siguientes:



0034-931294512



atencioncliente@aosom.es

IMPORTADOR:

SPANISH AOSOM, S.L.

C/ ROC GROS, N° 15. 08550, ELS HOSTALET DE
BALENYÀ, SPAIN.

B66295775

WWW.AOSOM.ES

ATENCIONCLIENTE@AOSOM.ES

TEL: 931294512

HECHO EN CHINA

FR

Si vous avez la moindre question, veuillez contacter notre centre d'assistance à la clientèle.

Nos coordonnées sont les suivantes:



0033-1-84166106



aosom@mhfrance.fr

Importé par:

MH France

2, rue Maurice Hartmann

92130 Issy-les-Moulineaux

France

Fabriqué en Chine

PT

Se tiver alguma dúvida, por favor contacte o nosso Centro de Atendimento ao Cliente. Os nossos dados de contacto são os seguintes:



0034-931294512



atencioncliente@aosom.es

IMPORTADOR:

SPANISH AOSOM, S.L

C.ROC GROS N.15, 08550. ELS HOSTALET DE BALENYÀ

TEL: 931294512 (SEG-SEX DAS 7:30H ÀS 16:30H)

INFO@AOSOM.PT

WWW.AOSOM.PT

DE

Wenn Sie Fragen haben, wenden Sie sich bitte an unser Kundendienstzentrum.

Unsere Kontaktdaten stehen unten:



0049-0(40)-88307530



service@aosom.de

ADRESSE DES IMPORTEURE:

MH Handel GmbH

Wendenstraße 309

D-20537 Hamburg

Germany

IN CHINA HERGESTELLT

IT

In caso di dubbio, si prega di contattare il nostro centro assistenza clienti. I nostri dettagli di contatto sono di seguito:



0039-0249471447



clienti@aosom.it

IMPORTATO DA:

AOSOM Italy srl

Centro Direzionale Milanofiori

Strada 1 Palazzo F1

20057 Assago (MI)

P.I.: 08567220960

FATTO IN CINA

US

If you have any questions, please contact our customer care center.
Our contact details are below:



001-877-644-9366



customerservice@aosom.com

Imported by Aosom LLC
27150 SW Kinsman Rd Wilsonville, OR 97070 USA
Manufactured in Ningbo City, Zhejiang Province, China
MADE IN CHINA

CA

If you have any questions, please contact our customer care center.
Our contact details are below:

Si vous avez la moindre question, veuillez contacter notre centre d'assistance à la clientèle.
Nos coordonnées sont les suivantes:



416-792-6088



customerservice@aosom.ca

Imported by Aosom Canada Inc.
1251 Tapscott Road, Unit 101, Scarborough, Ontario Canada M1X 1S9
Manufactured in Ningbo City, Zhejiang Province, China
MADE IN CHINA

Importé par Aosom Canada Inc.
1251 Rue Tapscott, Unité 101, Scarborough, Ontario Canada M1X 1S9
Fabriqué à Ville de Ningbo, Province du Zhejiang, Chine
FABRIQUÉ EN CHINE

