

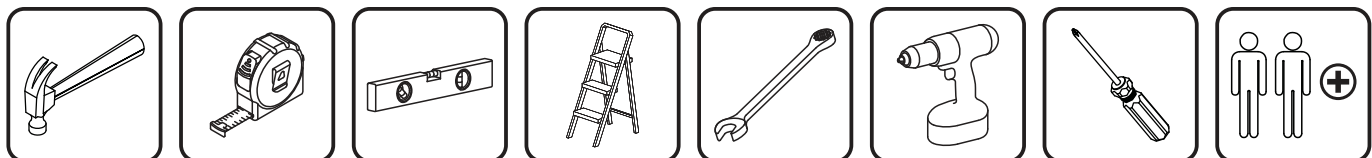

IN221001943V02_GL

845-059_845-059V00

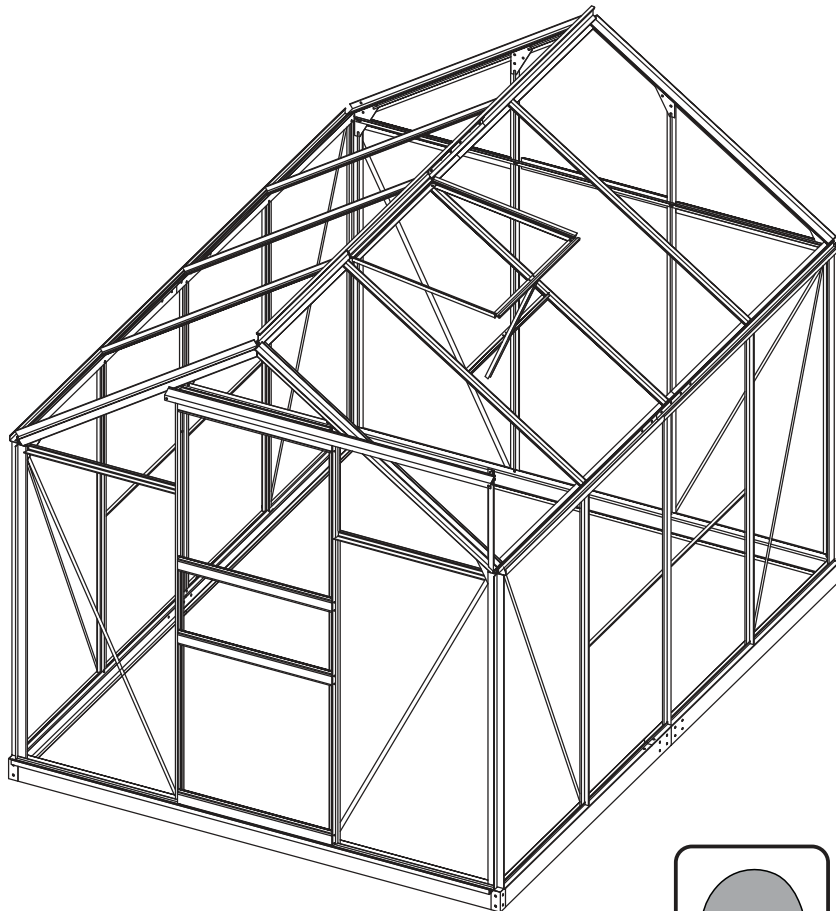

Tools Recommended

EN_IMPORTANT, RETAIN FOR FUTURE REFERENCE: READ CAREFULLY.

FR_IMPORTANT: A LIRE ATTENTIVEMENT ET À CONSERVER POUR CONSULTATION ULTÉRIEURE.























































ES_IMPORTANTE, LEA Y GUARDE PARA FUTURAS REFERENCIAS.

PT_IMPORTANTE, RETER PARA REFERÊNCIA FUTURA: LEIA ATENTAMENTE.

DE_WICHTIG! SORGFÄLTIG LESEN UND FÜR SPÄTER NACHSCHLAGEN AUFBEWAHREN.

IT_IMPORTANTE! CONSERVARE IL PRESENTE MANUALE PER FUTURO RIFERIMENTO E LEGGERLO ATTENTAMENTE.

PACKING DETAILS: TOTAL 2 BOXES

Box 1/2			Box 2/2			
Name of parts	Section	QTY(pecs)	Name of parts	Section	QTY(pecs)	
F-14b		2	F-23		6	
F-15		2	F-24		6	
F-27		1	F-C02		2	
F-12		1	F-C02a		2	
F-21		1	F-C05		2	
F-17		4	F-C05a		2	
F-17i		2	F-48		5	
F-25		1	F-C06		2	
F-26		2	F-C06a		2	
F-28		1	F-13		1	
F-20		1	F-16b		2	
F-01		4	F-18i		1	
F-43		2	F-41		2	
F-02		2	F-29		4	
F-C01		2	F-30		4	
F-C01a		2	F-22b		4	
F-42		2	G-P1		4	
F-03b		1	G-P2		2	
F-04		1	G-P3L		1	
F-C07		1	G-P3R		1	
F-C07a		1	F-19		8	
F-05		4	F-C13		18	
F-06		2	F-C14		188	
F-07		2	F-C15a		12	
F-08		1	F-C16		6	
F-09		1	F-C18g		115	
F-10		1	F-C17g		85	
F-11		1	F-C17h		30	
			F-31a 			5
			F-31b 			1
			F-32a 			2
			F-33a 			2
			F-34 			8
			F-35 			7
			F-36 			1
			F-37 			1
			F-38 			2
			F-39 			1
			F-40 			1
			Instruction manual			1

TO PREVENT INJURY, READ AND UNDERSTAND THE GREENHOUSE ASSEMBLY INSTRUCTIONS BEFORE USE.

GENERAL SAFETY, WARNINGS AND PRECAUTIONS

KEEP WORK AREA CLEAN AND DRY.

Cluttered, damp or wet work areas invite injuries.

STAY ALERT. Watch what you are doing at all times. Use common sense. Do not use the greenhouse when you are tired or distracted from the job at hand. It is recommended to use gloves for assembling the greenhouse.

MAINTAIN THIS PRODUCT WITH CARE.

Keep the greenhouse clean and dry for better performance: maintenance should be performed regularly.

USE THE RIGHT PRODUCT FOR THE JOB.

Do not attempt to force a small product to do the work of a larger industrial product. There are certain applications for which the greenhouse was designed. It will do the job better and more safely in the manner for which it was intended. Do not modify the greenhouse and do not use the greenhouse for a purpose for which it was not intended.

MAINTAIN A SAFE WORKING ENVIRONMENT.

Keep the work area tidy. Make sure there is adequate surrounding workspace. Avoid high traffic areas. Always keep the work area free of obstructions, grease, oil, trash and other debris.

PROPER GREENHOUSE LOCATION.

Make sure the greenhouse is located on a flat level surface.

POUR ÉVITER LES RISQUES DE BLESSURES, VEILLEZ LIRE ET COMPRENDRE LES INSTRUCTIONS DE MONTAGE DE LA SERRE AVANT DE L'UTILISER.

SÉCURITÉ GÉNÉRALE, AVERTISSEMENTS ET PRÉCAUTIONS

GARDER LA ZONE DE TRAVAIL PROPRE ET SÈCHE.

Les zones de travail encombrées, humides ou mouillées sont propices aux blessures.

RESTEZ VIGILANT. Surveillez ce que vous faites à tout moment. Faites preuve de bon sens. N'utilisez pas la serre lorsque vous êtes fatigué ou distrait du travail en cours. Il est recommandé d'utiliser des gants pour le montage de la serre.

ENTRETIENEZ CE PRODUIT AVEC SOIN.

Gardez la serre propre et sèche pour un meilleur rendement : l'entretien doit être effectué régulièrement.

UTILISEZ LE PRODUIT APPROPRIÉ POUR LE TRAVAIL À EFFECTUER.

N'essayez pas de forcer un petit produit à faire le travail d'un produit industriel plus important. La serre a été conçue pour certaines applications. Elle fera mieux le travail pour lequel elle a été conçue et de manière plus sûre. Ne modifiez pas la serre et n'utilisez pas la serre à des fins pour lesquelles elle n'a pas été conçue.

MAINTENIR UN ENVIRONNEMENT DE TRAVAIL SÛR.

Maintenez l'espace de travail en ordre. Assurez-vous que l'espace de travail environnant est adéquat. Évitez les zones à forte circulation. Maintenez la zone de travail toujours libre de tout obstacle, graisse, huile, déchets et autres débris.

EMPLACEMENT ADÉQUAT DE LA SERRE.

Veillez à ce que la serre soit située sur une surface plane et de niveau.

PARA PREVENIR LESIONES, LEA Y COMPRENDA LAS INSTRUCCIONES DE MONTAJE DEL INVERNADERO ANTES DE USARLO.

SEGURIDAD GENERAL, ADVERTENCIAS Y PRECAUCIONES

MANTENGA EL ÁREA DE TRABAJO LIMPIA Y SECA.

Las áreas de trabajo desordenadas, húmedas o mojadas pueden provocar lesiones.

MANTÉNGASE ALERTA. Vigile lo que está haciendo en todo momento con el conocimiento común. No use el invernadero cuando esté cansado o distraído del trabajo en cuestión. Se recomienda utilizar guantes para montar el invernadero.

MANTENGA ESTE PRODUCTO CON CUIDADO.

Mantenga el invernadero limpio y seco para un mejor rendimiento: el mantenimiento debe realizarse con regularidad.

USE EL PRODUCTO ADECUADO PARA EL TRABAJO.

No intente forzar a un producto pequeño a hacer el trabajo que debe hacerse por un producto industrial más grande. Existen determinadas aplicaciones para las que se ha diseñado el invernadero. Puede hacer el trabajo mejor y con más seguridad si se usa en la manera para la que fue diseñado. No modifique el invernadero y no lo utilice para fines para los que no fue diseñado.

MANTENGA UN AMBIENTE DE TRABAJO SEGURO.

Mantenga el área de trabajo ordenada. Asegúrese de que haya un espacio de trabajo circundante adecuado. No lo use en las áreas de mucho tráfico. Mantenga siempre el área de trabajo libre de obstrucciones, grasa, aceite, basura y otros desechos.

UBICACIÓN APROPIADA DEL INVERNADERO.

Asegúrese de que el invernadero esté ubicado en una superficie plana y nivelada.

Um Verletzungen zu vermeiden, lesen und verstehen Sie bitte vor dem Gebrauch die Anweisungen zur Montage des Gewächshauses.

Allgemeine Sicherheit, Warnhinweise und Vorsichtsmaßnahmen

Halten Sie Arbeitsbereich sauber und trocken .

Überfüllte, feuchte oder nasse Arbeitsbereiche können zu Verletzungen führen.

WACHSAM BLEIBEN. Beobachten Sie jederzeit, was Sie tun. Verwenden Sie gesunden Menschenverstand. Verwenden Sie das Gewächshaus nicht, wenn Sie müde oder von der anstehenden Aufgabe abgelenkt sind. Es wird empfohlen, für die Montage des Gewächshauses Handschuhe zu tragen.

Behalten Sie dieses Produkt mit Pflege

Halten Sie das Gewächshaus sauber und trocken, um eine bessere Leistung zu erzielen: Regelmäßige Wartungsarbeiten sollten durchgeführt werden.

Verwenden Sie das richtige Produkt für den Job

Versuchen Sie nicht, ein kleines Produkt zu zwingen, die Arbeit eines größeren Industrieprodukts zu erledigen. Es gibt bestimmte Anwendungen, für die das Gewächshaus konzipiert wurde. Es wird die Arbeit besser und sicherer in der Weise erledigen, für die es bestimmt war. Ändern Sie das Gewächshaus nicht und verwenden Sie es nicht für Zwecke, für die es nicht vorgesehen war.

Sorgen Sie für ein sicheres Arbeitsumfeld.

Halten Sie den Arbeitsbereich sauber und ordentlich. Stellen Sie sicher, dass Sie genügend Arbeitsfläche um sich haben. Vermeiden Sie stark frequentierte Bereiche. Halten Sie den Arbeitsbereich immer frei von Hindernissen, Fett, Öl, Müll und anderen Fremdkörpern.

Richtige Gewächshauslage.

Stellen Sie sicher, dass sich das Gewächshaus auf einer ebenen Fläche befindet.

PER PREVENIRE LESIONI, LEGGETE E COMPRENDETE LE ISTRUZIONI DI ASSEMBLAGGIO DELLA SERRA PRIMA DELL'USO.

SICUREZZA GENERALE, AVVERTENZE E PRECAUZIONI

MANTENETE L'AREA DI LAVORO PULITA E ASCIUTTA.

Le aree di lavoro disordinate, umide o bagnate potrebbero provocare lesioni. **STAI ATTENTO.** Stai attento su cosa stai facendo in ogni momento. Usa il senso comune e non usare la serra quando sei stanco o distratto nel lavoro da svolgere. Si consiglia di utilizzare i guanti per l'assemblaggio della serra.

MANTENETE QUESTO PRODOTTO CON CURA.

Mantieni la serra pulita e asciutta per prestazioni migliori: la manutenzione deve essere eseguita regolarmente.

UTILIZZATE IL PRODOTTO GIUSTO PER IL LAVORO.

Non tentare di forzare un prodotto piccolo a svolgere un lavoro di un prodotto industriale più grande. Ci sono alcune applicazioni per le quali il prodotto è stato progettato. Il prodotto funzionerà meglio e più sicuro nel modo per cui è stato progettato. Non modificare la serra e non utilizzare la serra per scopi per i quali non è stata concepita.

MANTENETE UN AMBIENTE DI LAVORO SICURO.

Tieni in ordine l'area di lavoro. Assicurati che ci sia uno spazio di lavoro circostante adeguato. Evita le zone di molto traffico. Mantieni sempre l'area di lavoro libera da ostruzioni, grasso, olio, rifiuti e altri detriti.

POSIZIONE ADEGUATA DELLA SERRA.

Assicurati che la serra si trovi su una superficie piana e livellata.

EN

Notes:

1. Remove approximately 2 inches of film from all sheet edges before installing. remove all film immediately after the constructions completed.
2. The UV-protected side of the sheet is covered with opal white film and must face towards the sun.

FR

Notes:

1. Retirez environ 2 pouces de film de tous les bords de la feuille avant de l'installer. Retirez tout le film immédiatement à la fin des travaux.
2. La face de la feuille protégée contre les UV est recouverte d'un film blanc opale et doit être orientée vers le soleil.

ES

Notas:

1. Retire aproximadamente 2 pulgadas de película de todos los bordes de la hoja antes de instalar el producto. Retire toda la película inmediatamente después de completar la instalación.
2. El lado de la hoja protegido contra los rayos UV está cubierto con una película de color blanco ópalo y debe mirar hacia el sol.

DE

Anmerkungen:

1. Entfernen Sie vor der Installation ca. 2 Zoll Film von allen Blattkanten. Entfernen Sie den gesamten Film sofort nach Abschluss der Bauarbeiten.
2. Die UV-geschützte Seite des Blattes ist mit opalweißem Film bedeckt und muss der Sonne zugewandt sein.

IT

Nota:

1. Togli circa 2 pollici di pellicola da tutti i bordi del foglio prima dell'installazione. Togli tutta la pellicola immediatamente dopo aver completato le costruzioni.
2. Il lato protetto dai raggi UV del fogli, ricoperto da una pellicola bianca opalina, deve essere rivolto verso il sole.

Rear/Arrière/Trasero/Rückseite/Retro

GL

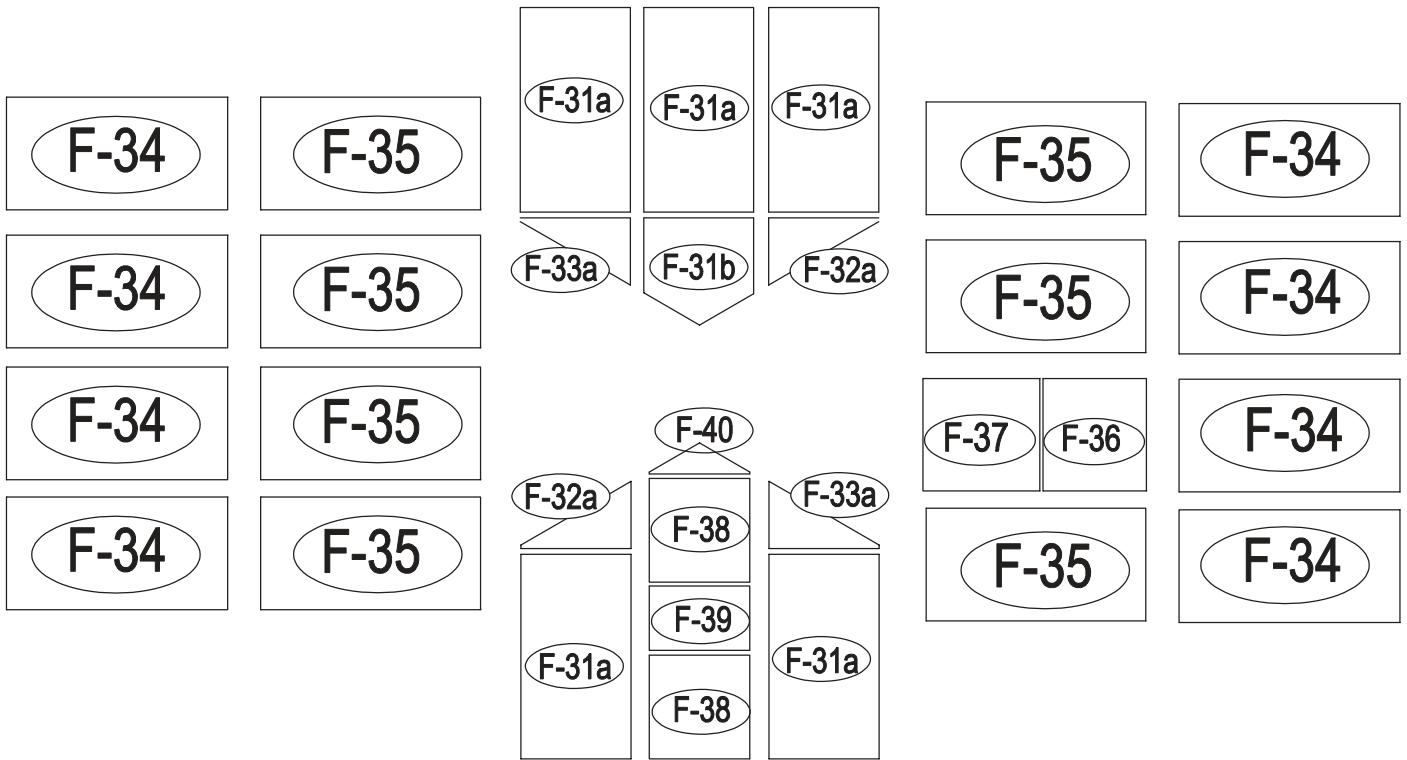

Front/Devant/Delantero/Vorderseite/Fronte

POLYCARBONATE PANEL

EN

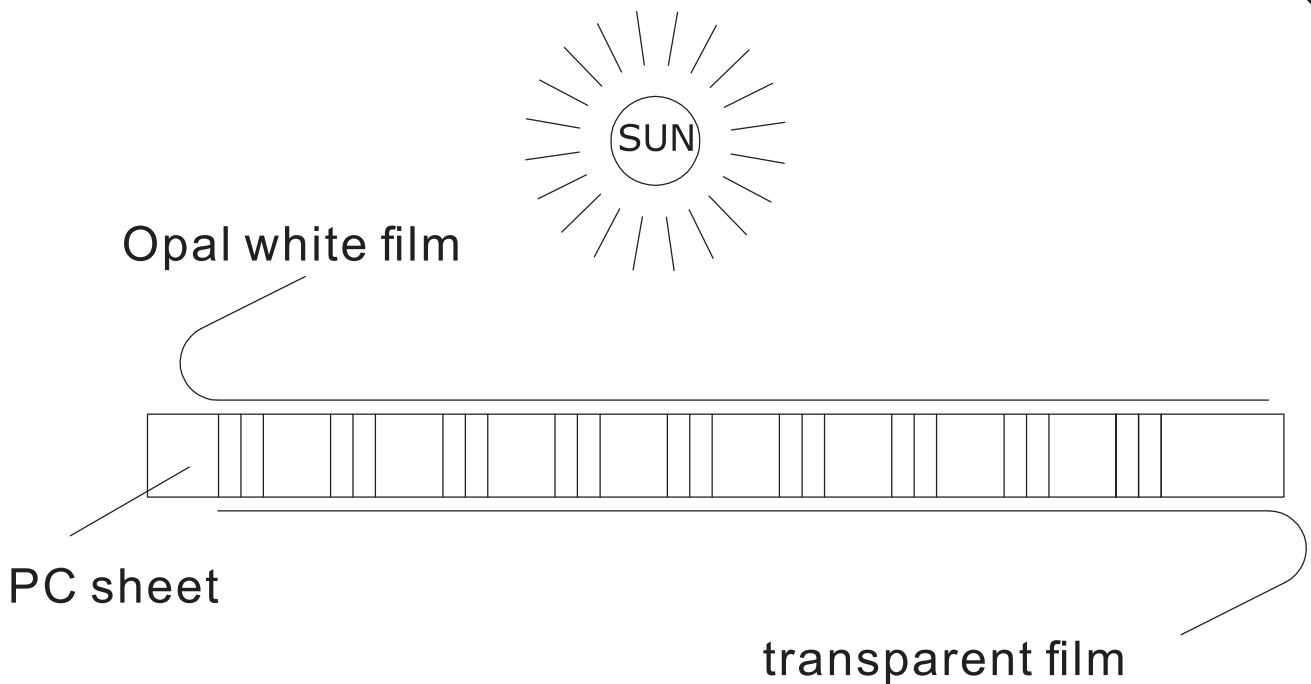

Two sides of PC sheet are covered with thin film, one side's film is transparent, another's film is opal white. The UV-protected side of the sheet is covered with opal white film and must face towards the sun.

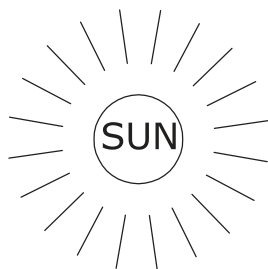

Film blanc opal



Feuille de PC

Film transparent

Les deux faces de la feuille de PC sont recouvertes d'un film fin, le film d'une face est transparent, celui de l'autre est blanc opale. La face de la feuille protégée contre les UV est celle recouverte d'un film blanc opale; elle doit être orientée vers le soleil.

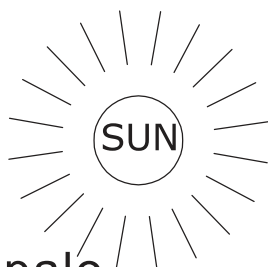

Película blanca ópalo



Lámina PC

Película transparente

Dos lados de la hoja de PC están cubiertos con una película delgada, la película de un lado es transparente y la película del otro es de color blanco ópalo. El lado de la hoja protegido contra los rayos UV está cubierto con una película de color blanco ópalo y debe mirar hacia el sol.

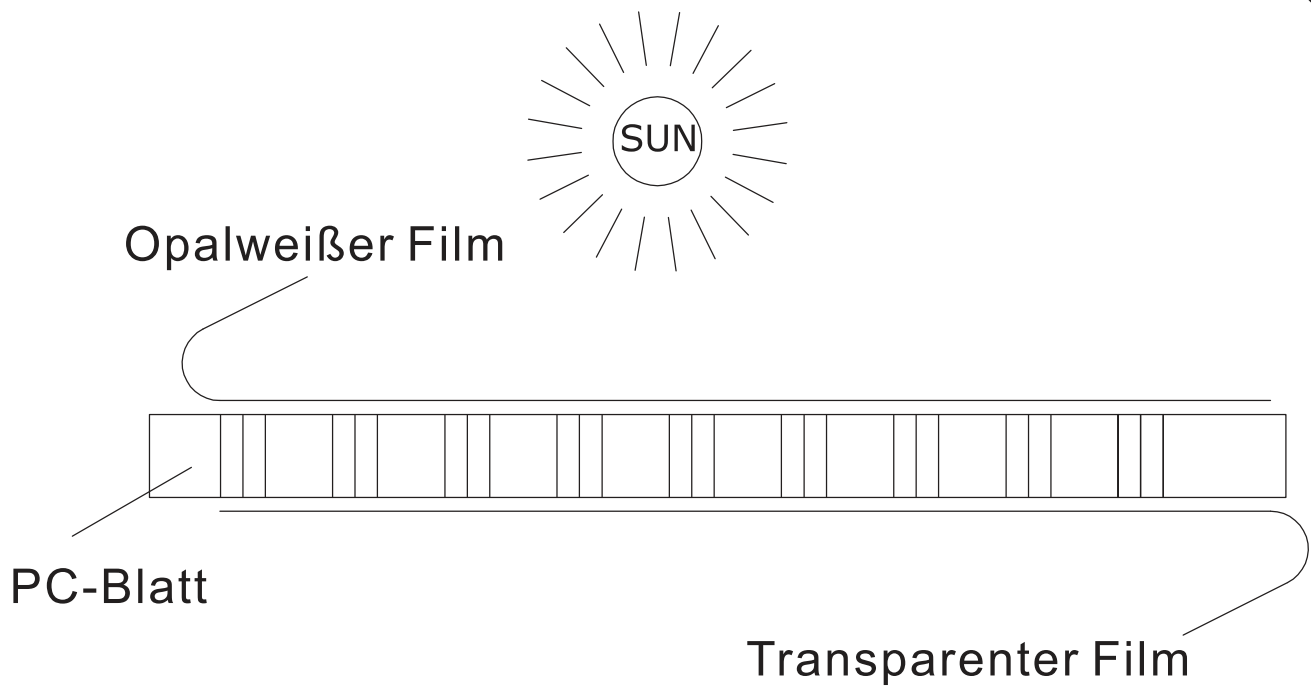

Zwei Seiten des PC-Blatts sind mit einem dünnen Film bedeckt, der Film einer Seite ist transparent, der Film einer anderen ist opalweiß. Die UV-geschützte Seite des Blattes ist mit opalweißem Film bedeckt und muss der Sonne zugewandt sein.

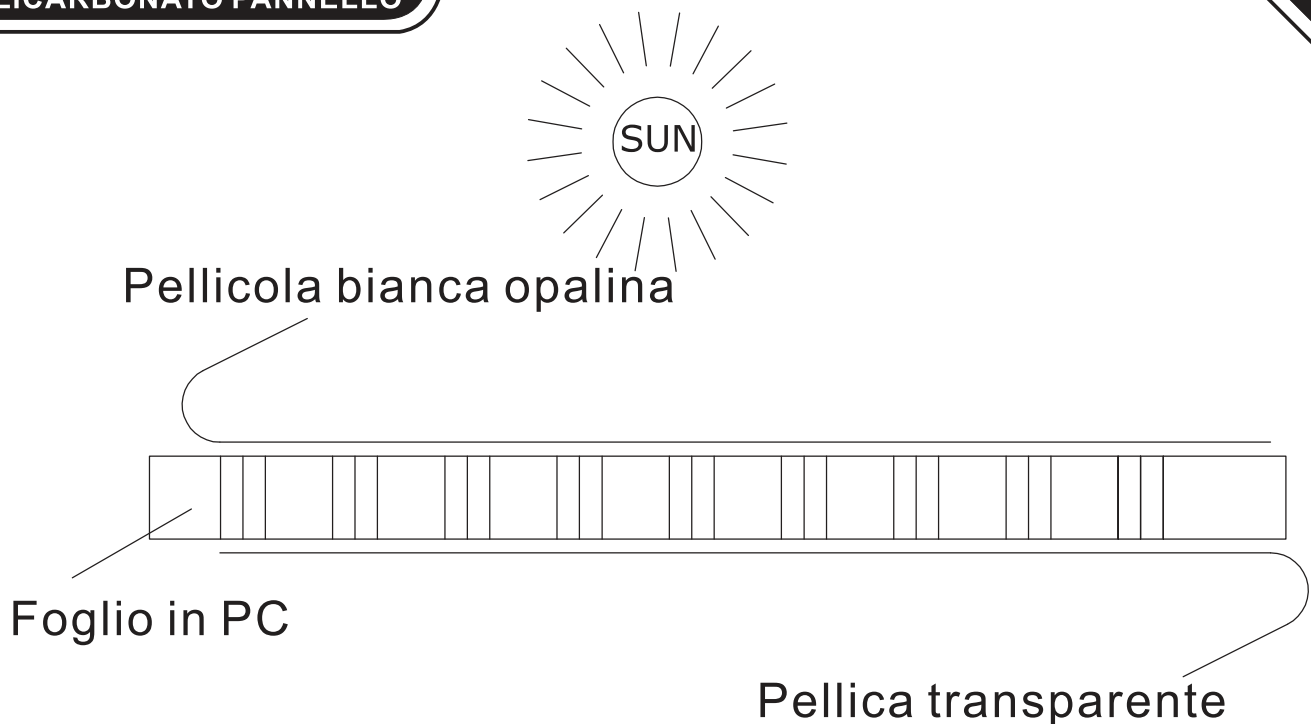

Due lati del foglio in PC sono ricoperti da pellicola sottile. La pellicola di un lato è trasparente, la pellicola di un altro è bianca opaca. Il lato protetto dai raggi UV del foglio ricoperto da una pellicola bianca opalina deve essere rivolto verso il sole.

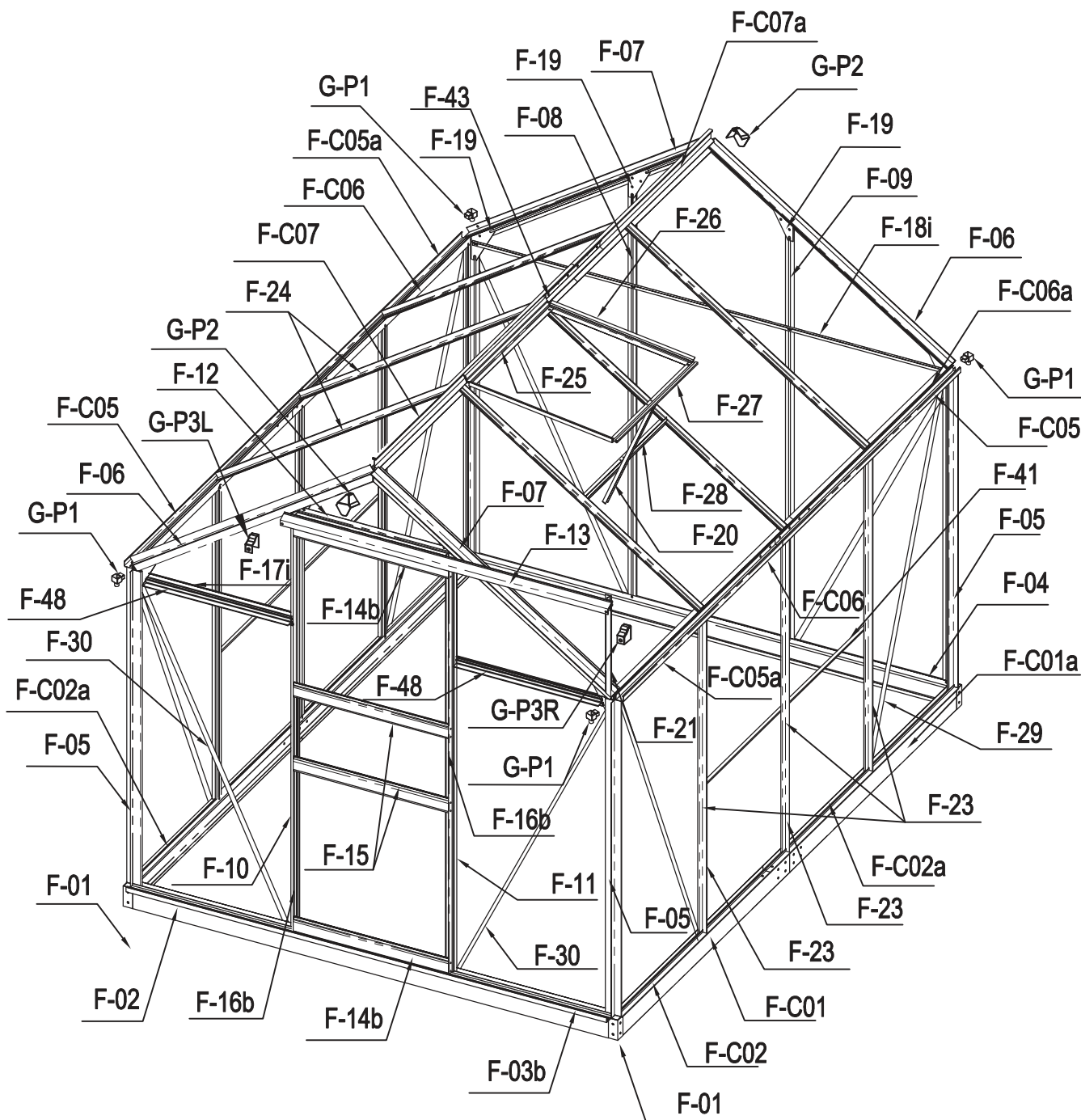

EN If you meet some difficult during the assembly, please loosen the relevant screws for adjustment first, and then tighten the screws again.











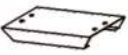

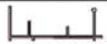

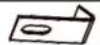
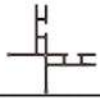

FR Si vous rencontrez des difficultés lors du montage, veuillez d'abord desserrer les vis correspondantes pour les ajustements, puis les resserrer.



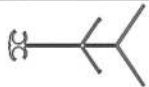

























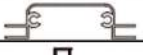

ES Si encuentra alguna dificultad durante el montaje, primero afloje los tornillos correspondientes para ajustar, y luego vuelva a apretarlos.

DE Wenn Sie während der Montage auf Schwierigkeiten stoßen, lösen Sie bitte zuerst die entsprechenden Schrauben zur Einstellung und ziehen Sie die Schrauben dann wieder fest.

IT In caso di difficoltà durante il montaggio, allentare innanzitutto le viti prima della regolazione, quindi stringere nuovamente le viti.

PARTSLIST

BASE			
IMAGE	NO.	L.	QTY
	F-01	280	4
	F-02	1882	2
	F-C01	1241	2
	F-C01a	1241	2
	F-03b	1833	1
	F-04	1833	1
	F-C02	1070	2
	F-C02a	1362	2
	F-42	200	2
	F-C13		18
WALL AND ROOF			
IMAGE	NO.	L.	QTY
	F-05	1240	4
	F-06	1105	2
	F-07	1105	2
	F-08	1650	1
	F-09	1650	1
	F-23	1240	6
	F-24	1100	6
	F-48	568	5
	F-10	1644	1
	F-11	1644	1
	F-C05	1286	2
	F-C05a	1150	2
	F-C06	1288	2
	F-C06a	1144	2
	F-17	618	4
	F-17i	618	2
	F-18i	1815	1
	F-41	1216	2
	F-29	1360	4
	F-30	1328	4
	F-C07	1432	1
	F-C07a	1000	1
	F-31a	1217x585	5
	F-31b	618x585	1
	F-32a	412x585	2
	F-33a	412x585	2
	F-34	1238x585	8

	F-35	1110x585	7
	F-36	540x585	1
	F-40		1
	F-43	390	2
	F-19		8
WINDOW			
IMAGE	NO.	L.	QTY
	F-20	360	1
	F-25	580	1
	F-26	550	2
	F-27	580	1
	F-28	620	1
	F-37	577x583	1
SCREW			
IMAGE	NO.	L.	QTY
	F-C14		188 +1(spare)
ST4x10 	F-C15a		12 +1(spare)
ST4x8 	F-C16		6 +1(spare)
	F-C18g		115 +1(spare)
	F-C17g		85 +1(spare)
	F-C17h		30 +1(spare)
DOOR			
IMAGE	NO.	L.	QTY
	F-12	572.5	1
	F-13	1240	1
	F-14b	600	2
	F-15	600	2
	F-16b	1615	2
	F-21	376	1
	F-22b		4
	F-38	590x598	2
	F-39	251x598	1
PLASTIC			
IMAGE	NO.	L.	QTY
	G-P1		4
	G-P2		2
	G-P3L		1
	G-P3R		1

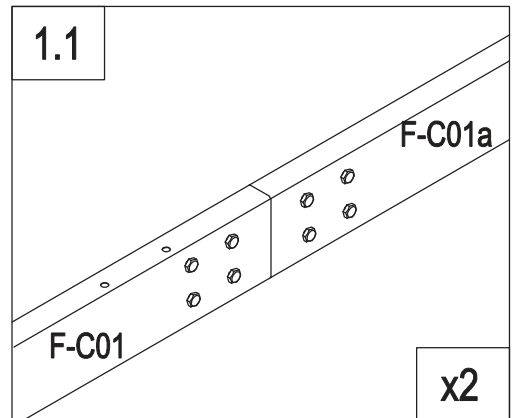
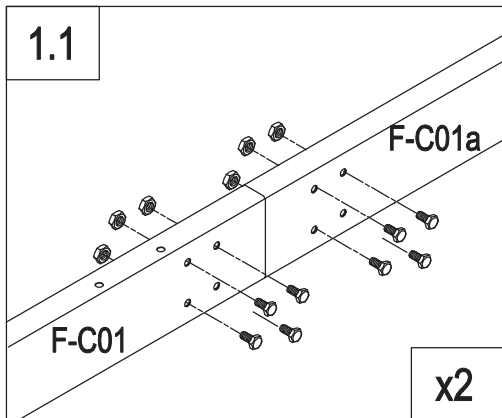
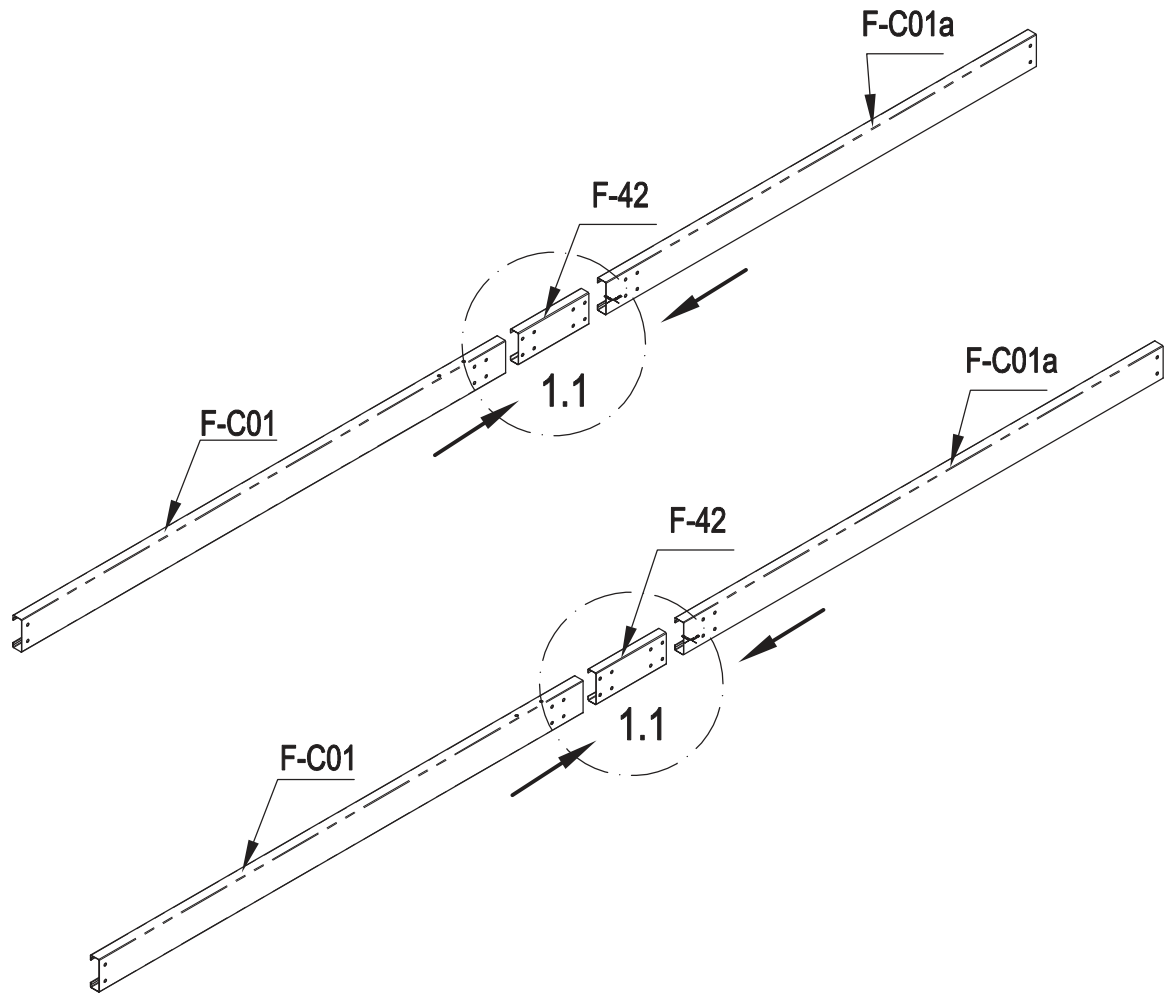



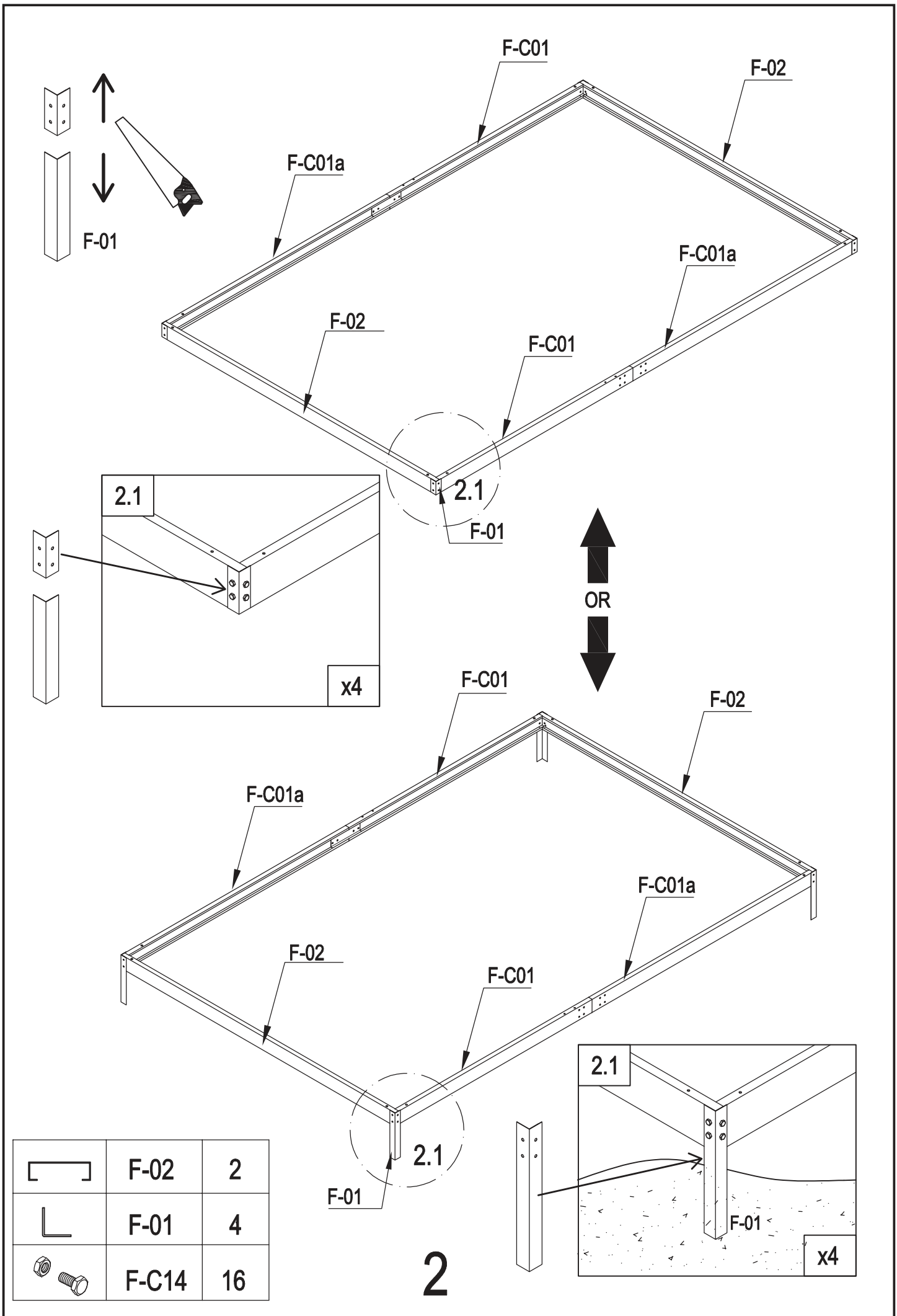

	F-C01	2
	F-C01a	2
	F-42	2
	F-C14	16

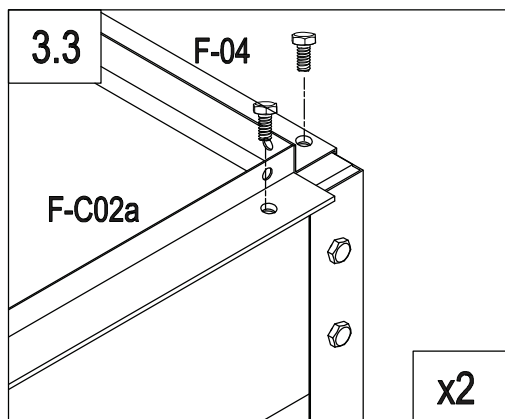
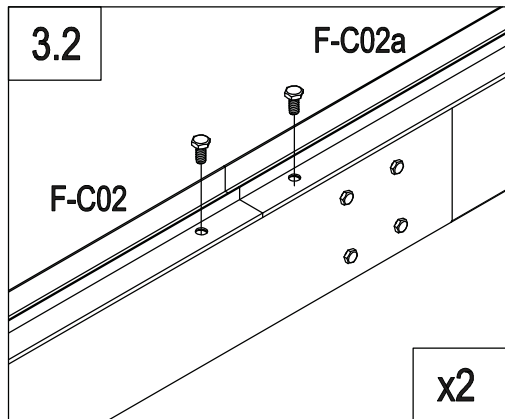
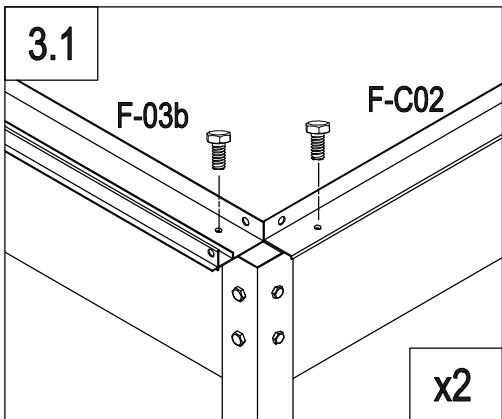
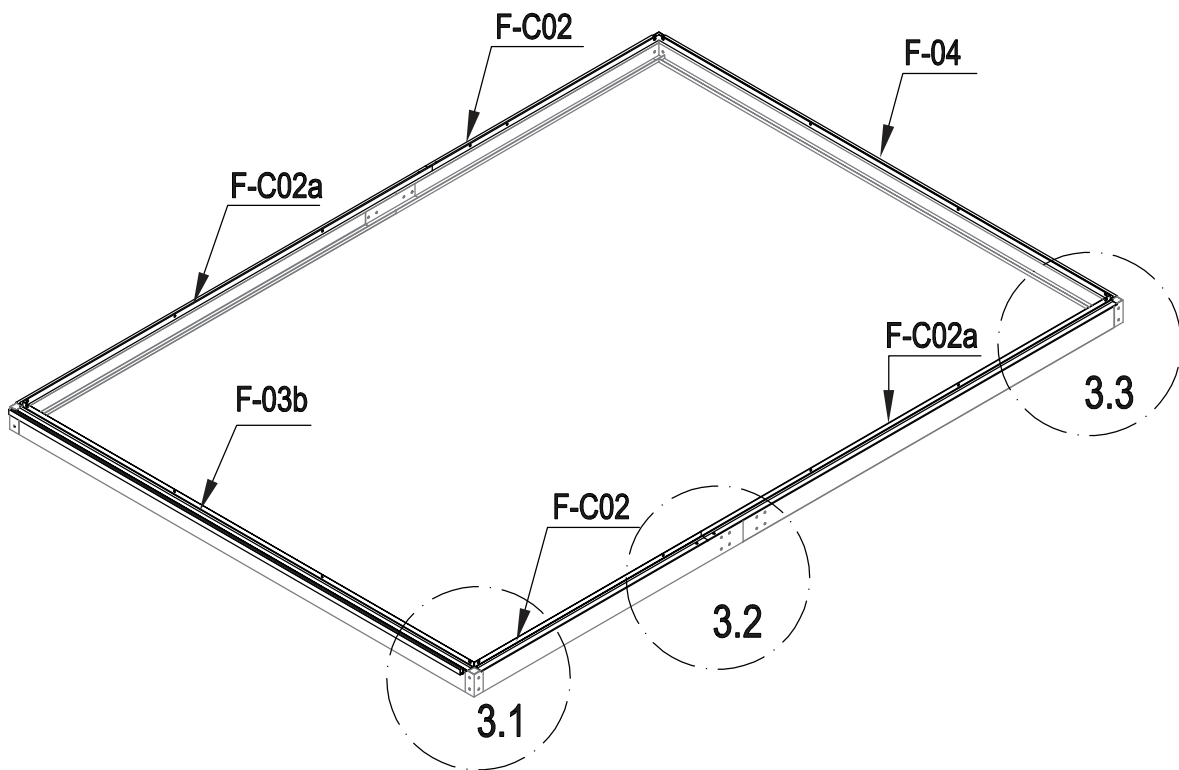
1





	F-C02	2
	F-C02a	2
	F-04	1
	F-03b	1
	F-C14	12

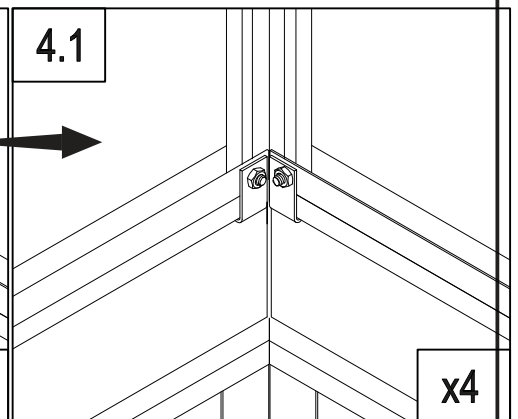
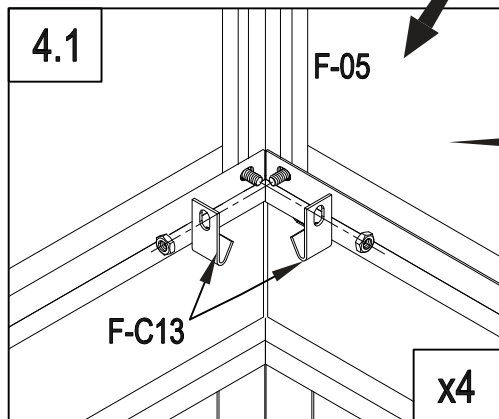
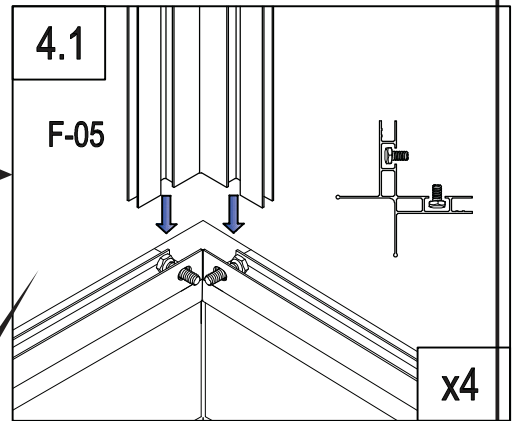
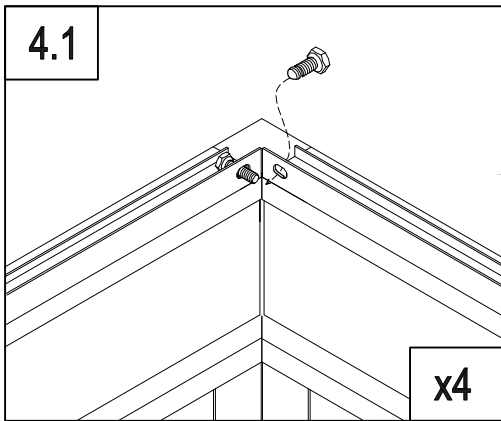
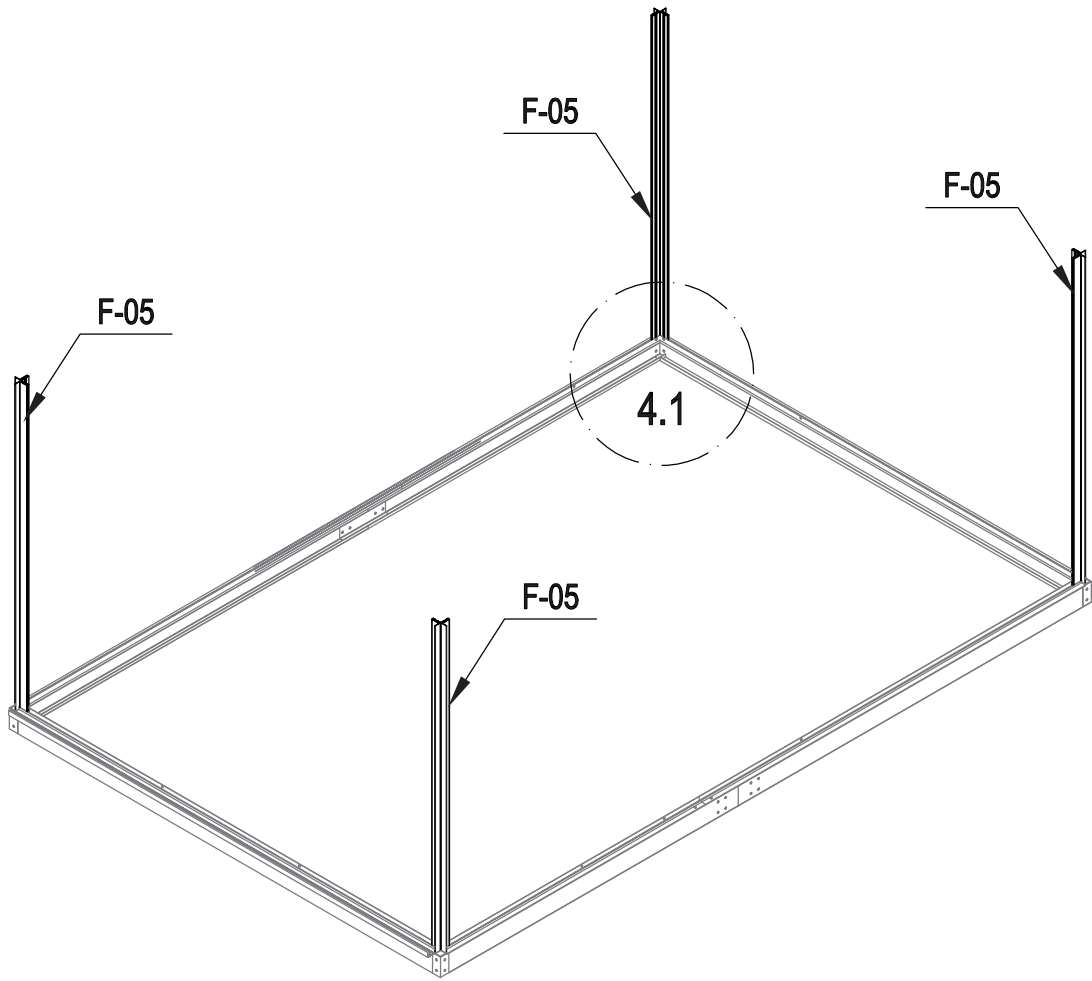

3

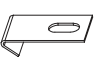
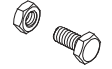

	F-05	4
	F-C13	8
	F-C14	8

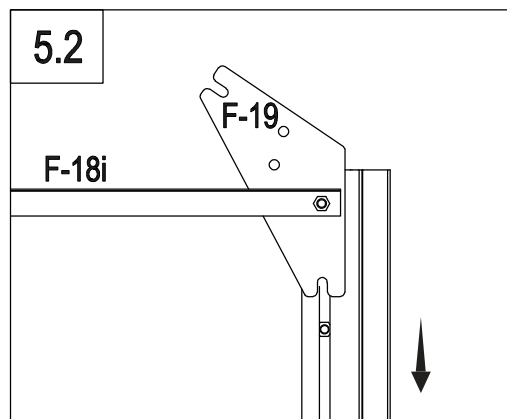
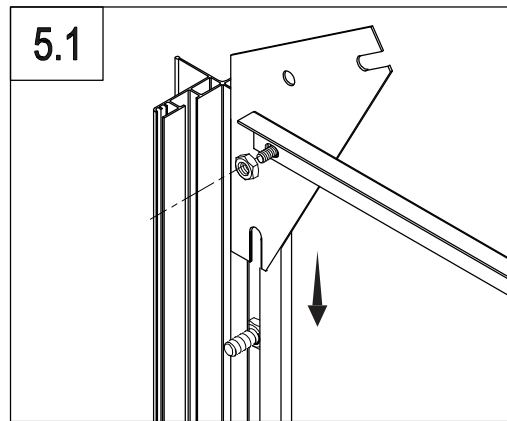
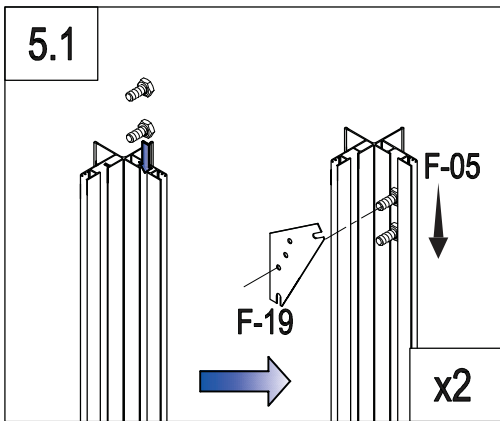
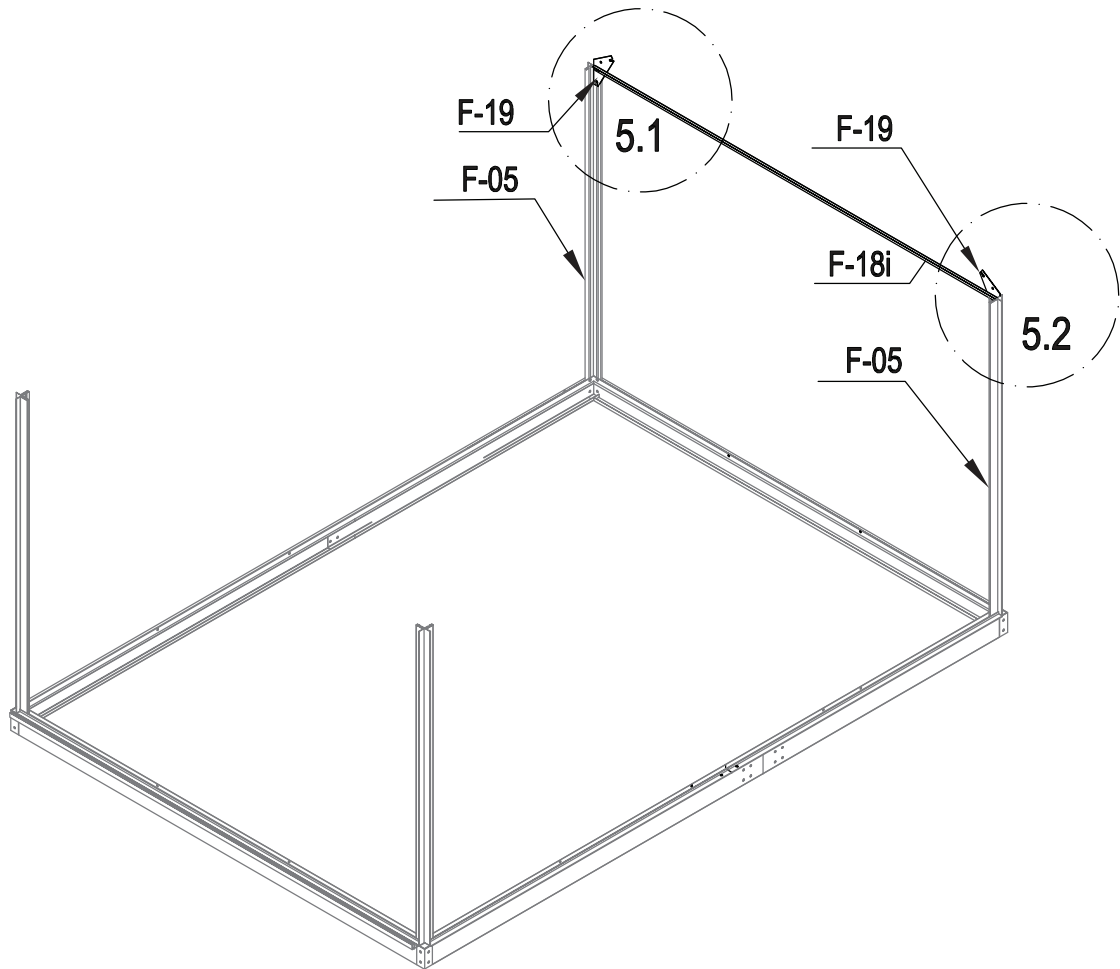
4



	F-18i	1
	F-19	2
	F-C14	4

5

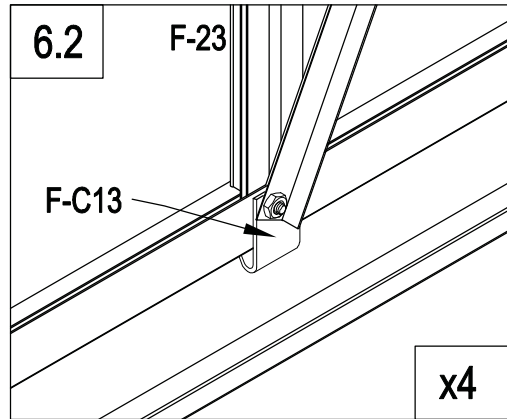
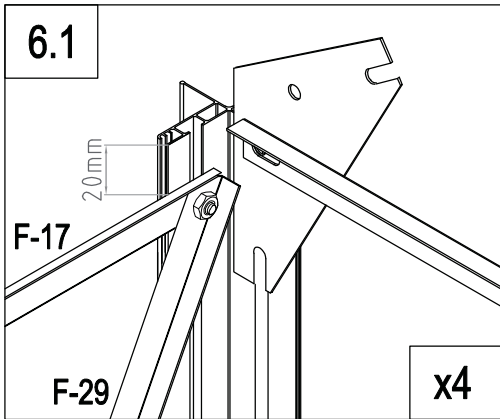
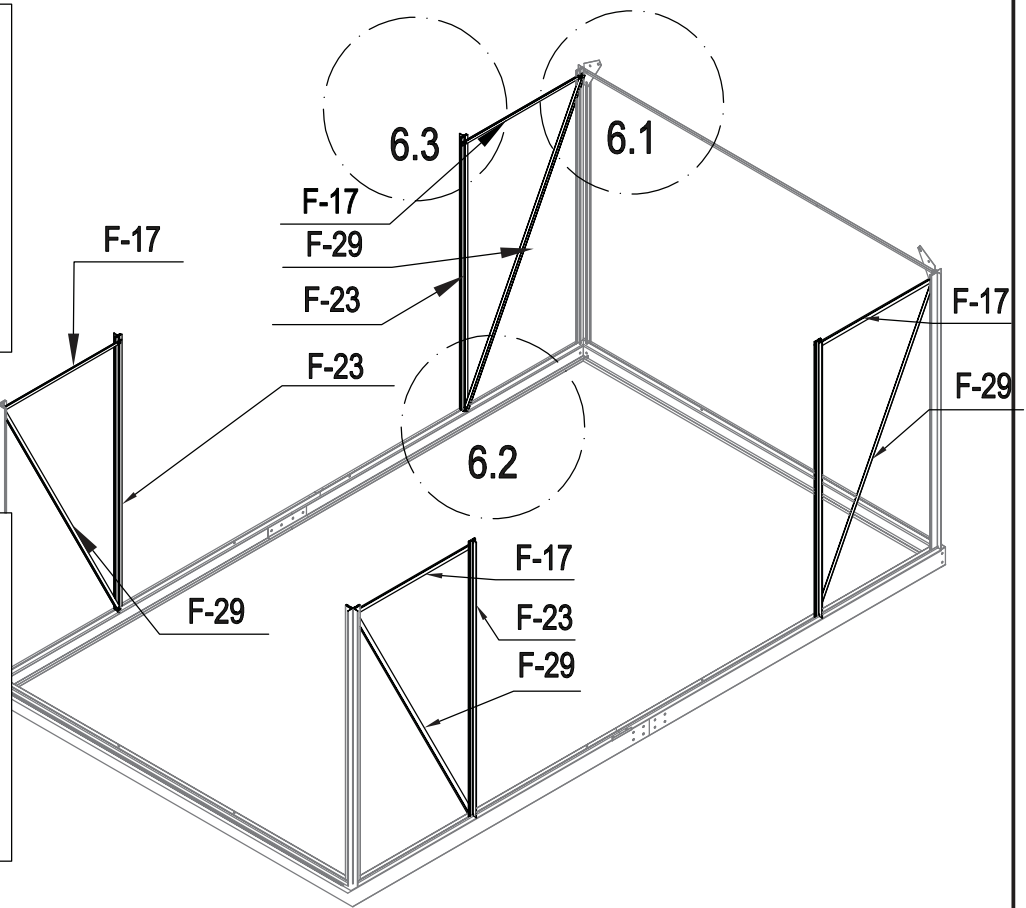
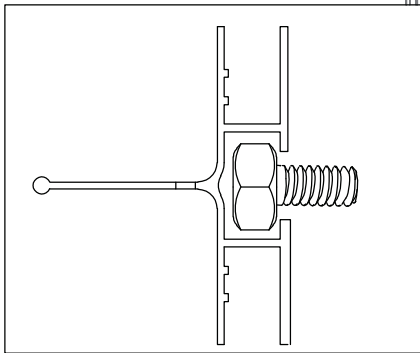
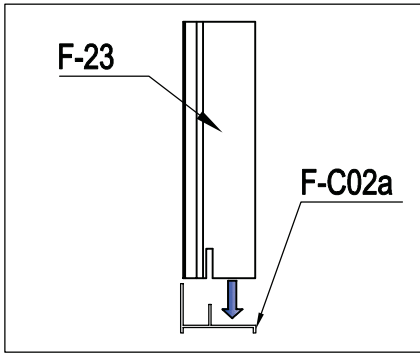

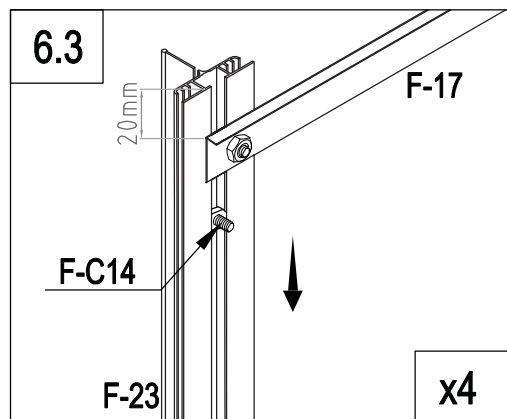

	F-C13	4
	F-17	4
	F-23	4
	F-29	4
	F-C14	16
	F-C14	12



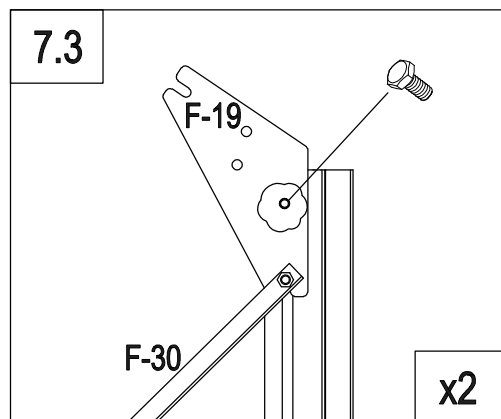
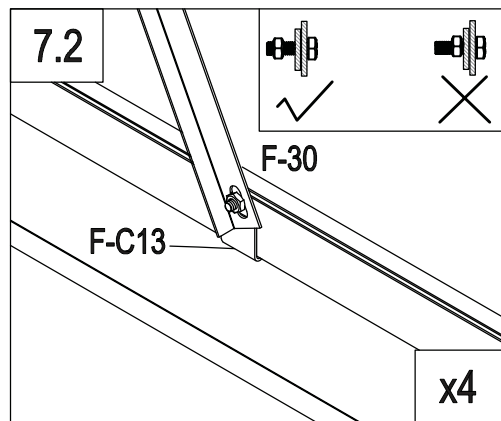
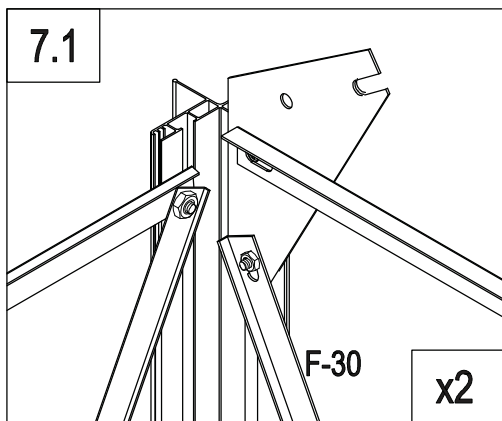
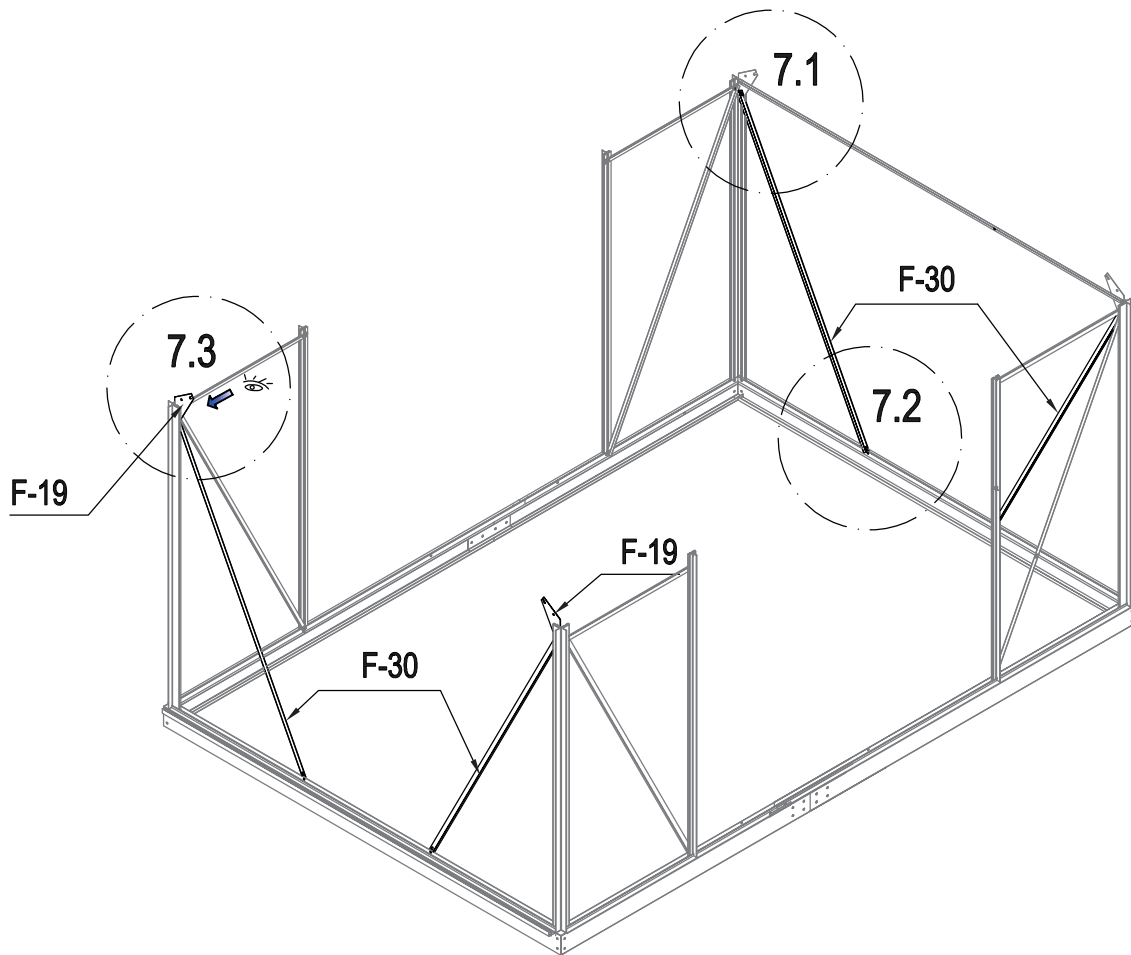

6

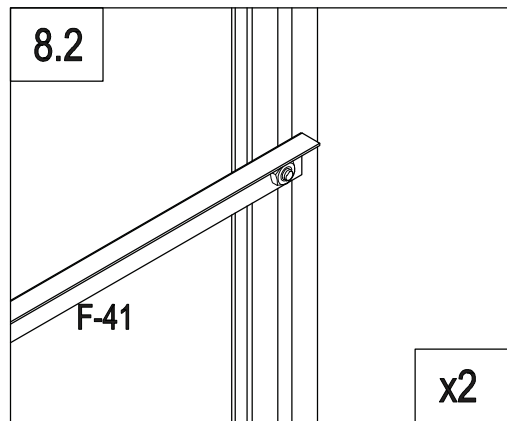
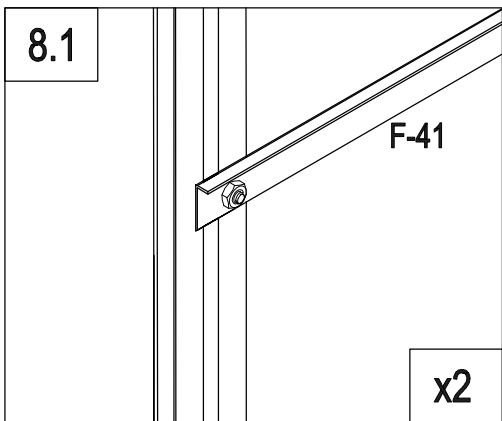
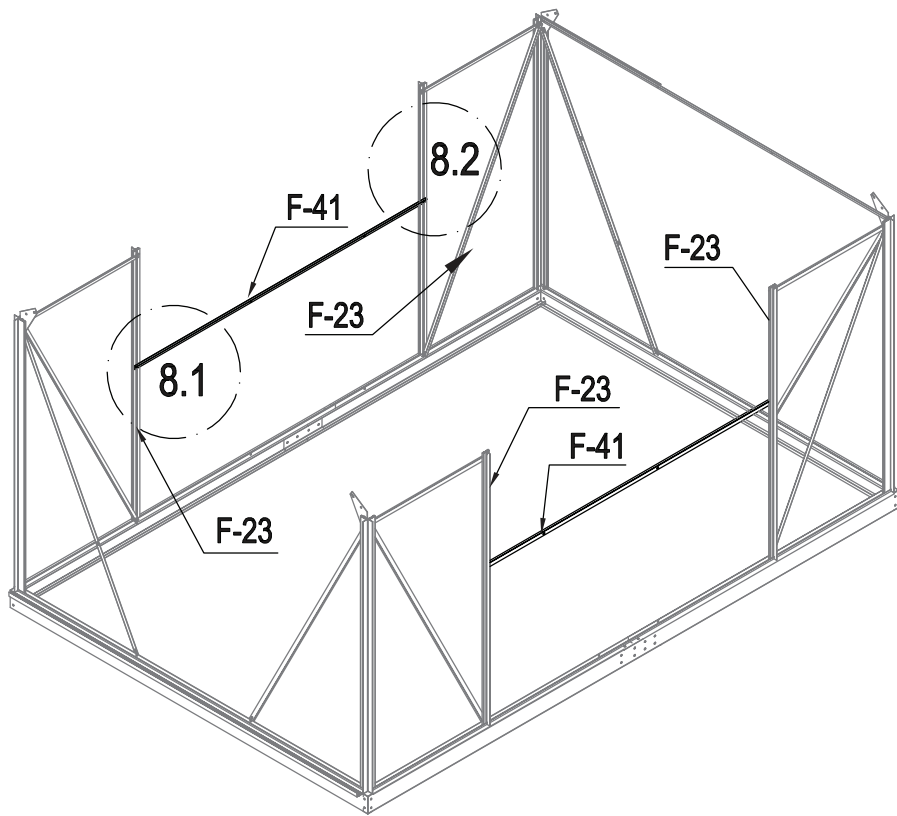

	F-C13	4
	F-30	4
	F-19	2
	F-C14	8

7



	F-41	2
	F-C14	4

8

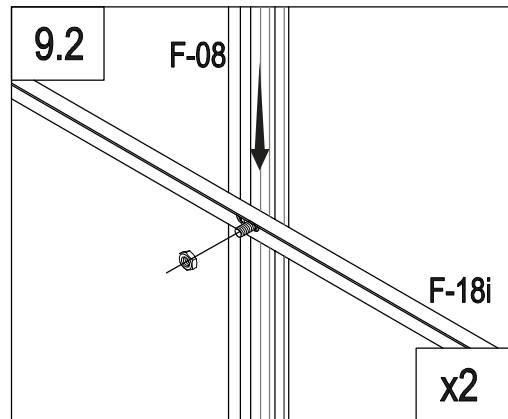
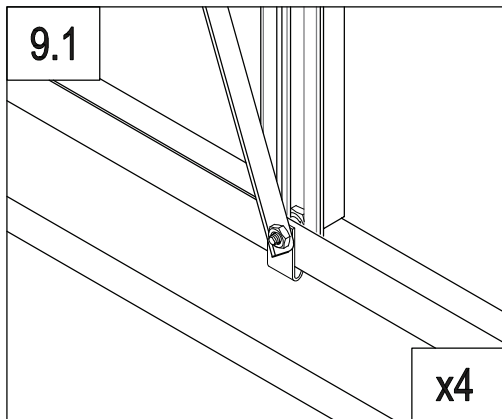
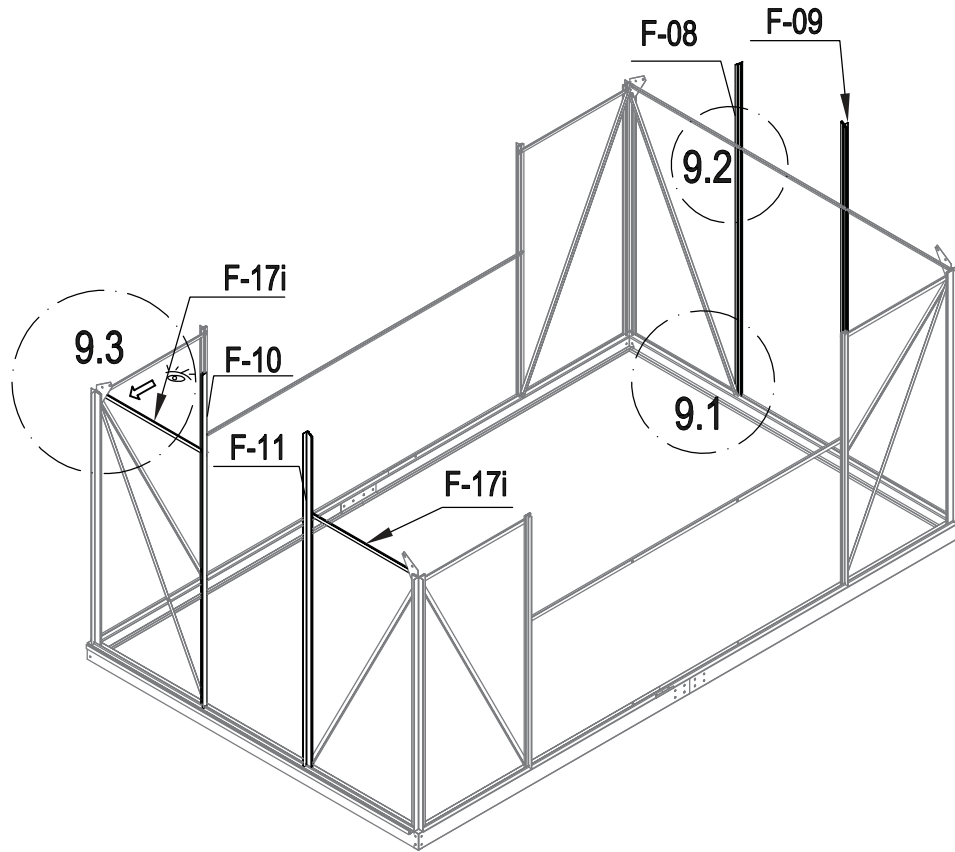

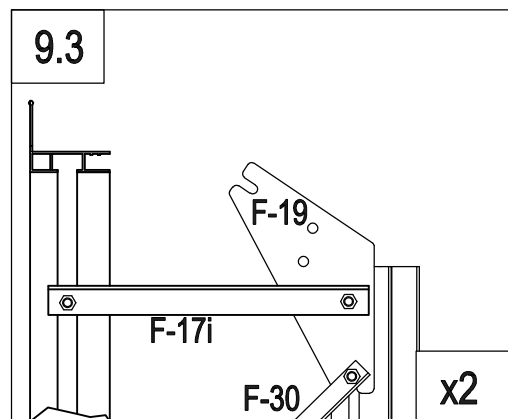

	F-08	1
	F-09	1
	F-10	1
	F-11	1
	F-17i	2
	F-C14	4

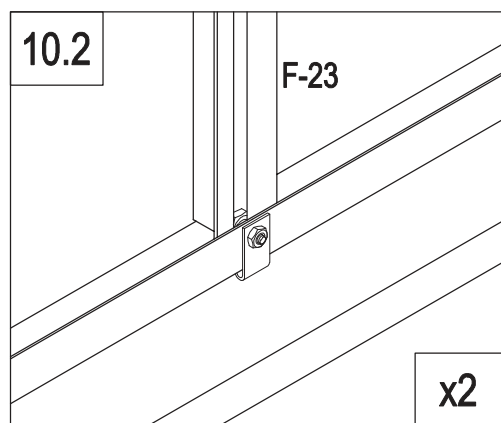
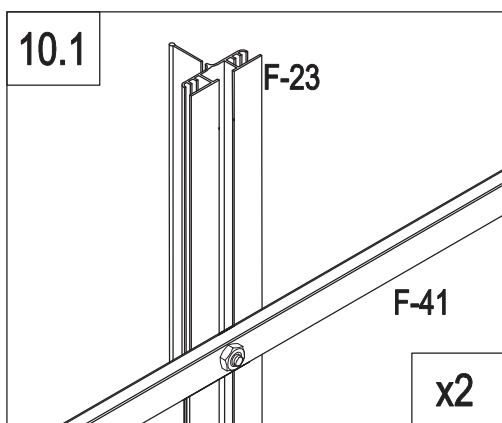
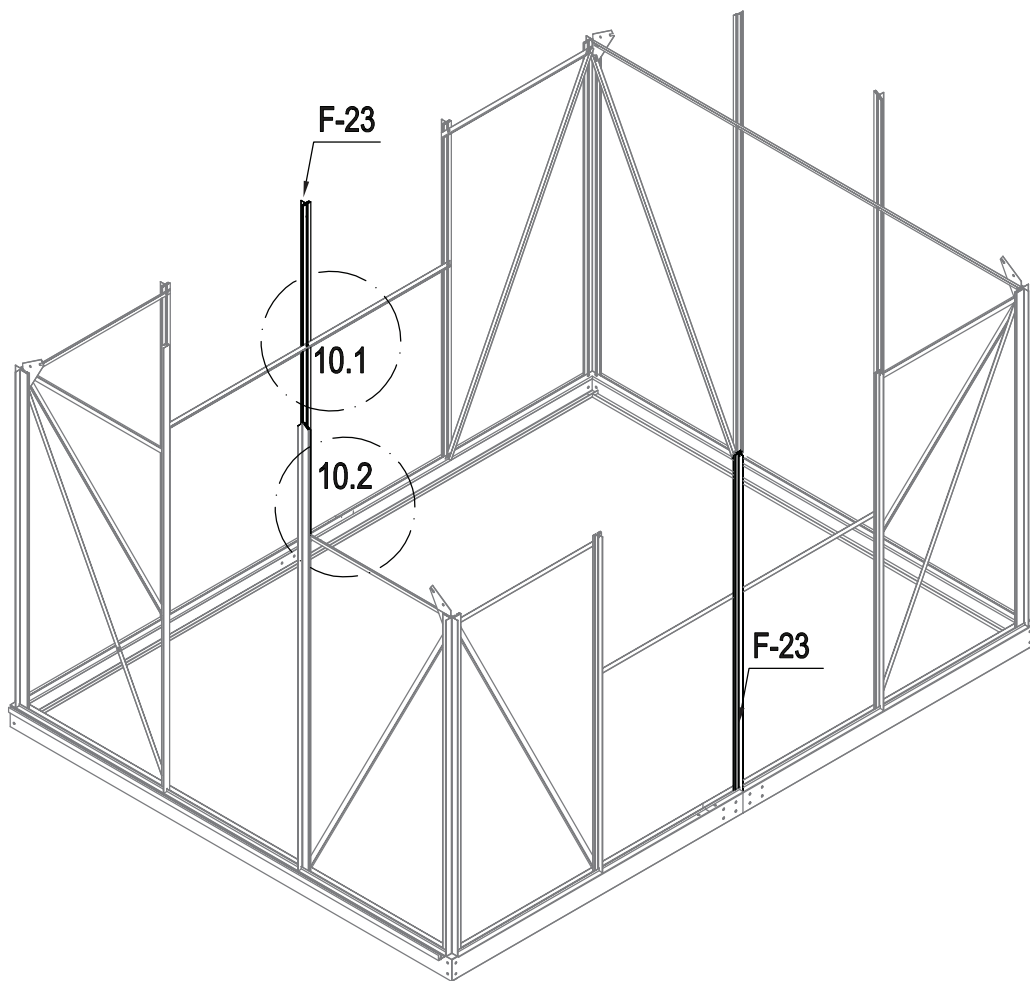

9

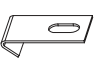

	F-C13	2
	F-23	2
	F-C14	4

10

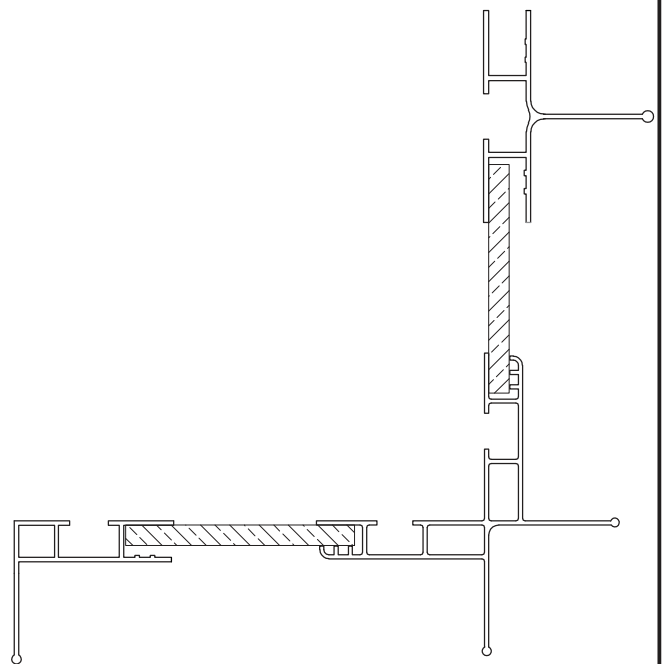
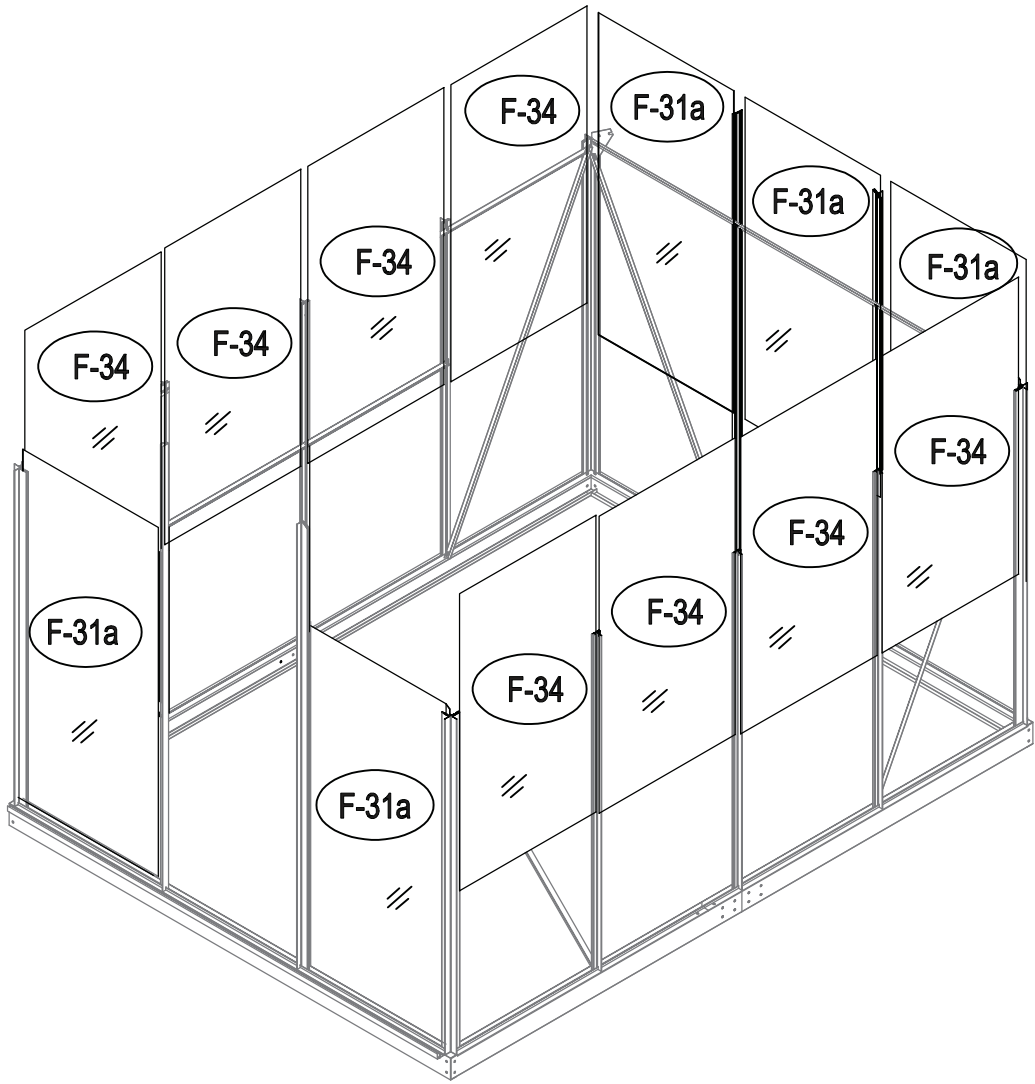

	F-31a	5
	F-34	8

11

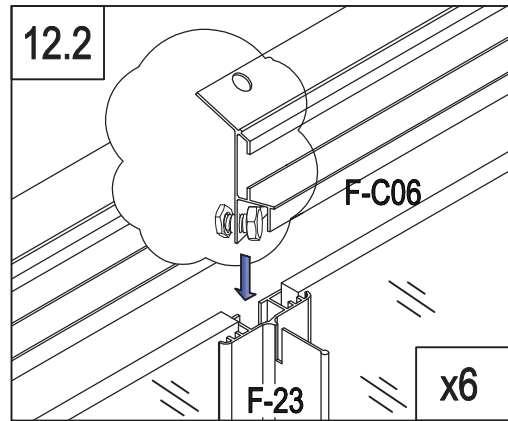
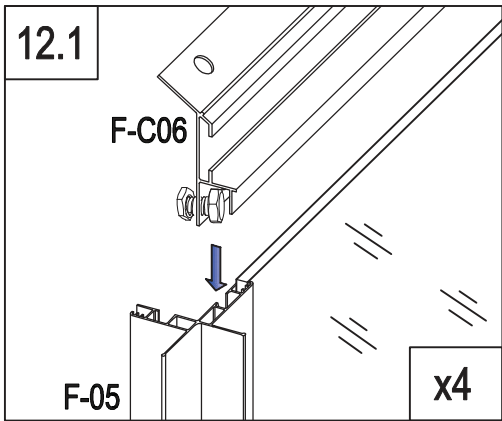
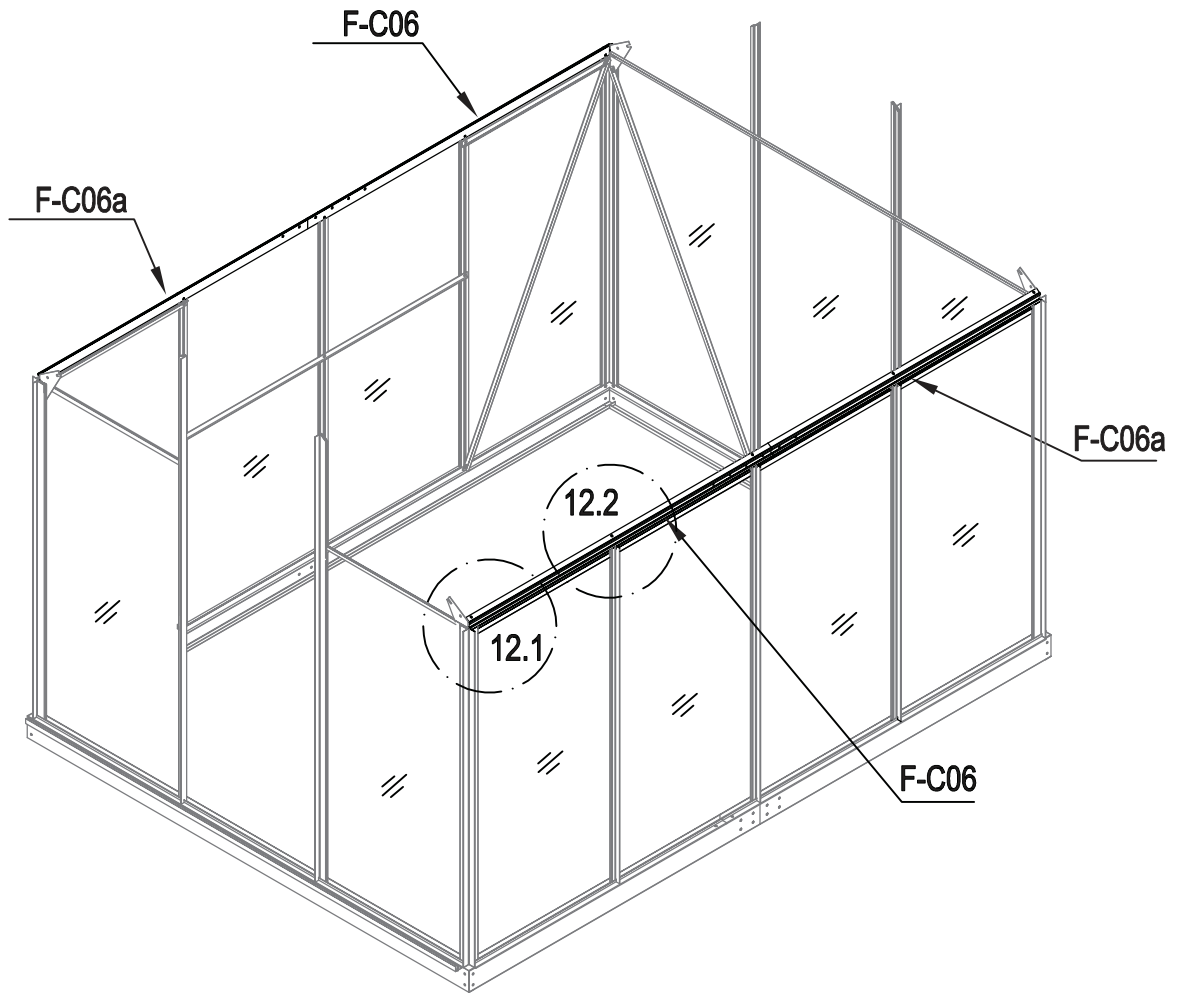

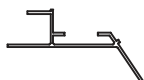
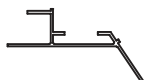
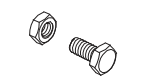
	F-C06	2
	F-C06a	2
	F-C14	10

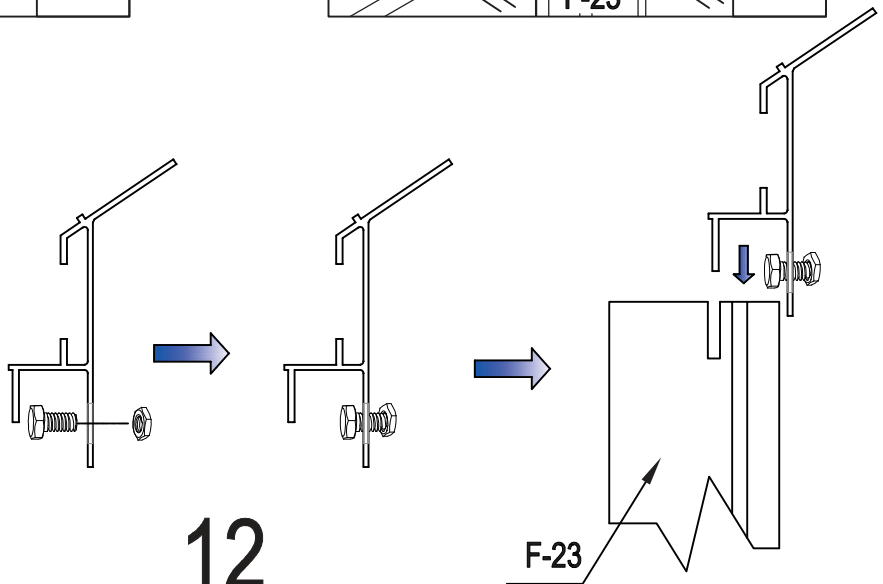

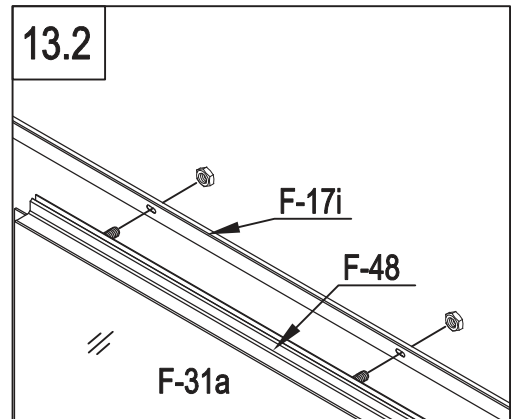
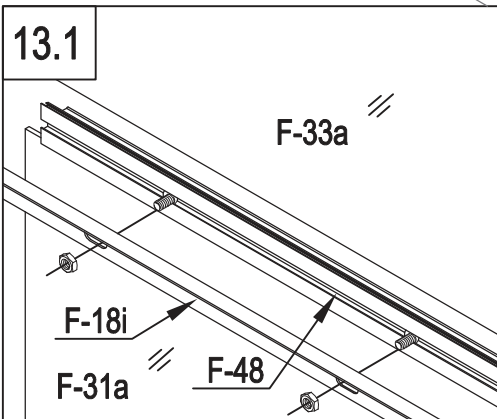
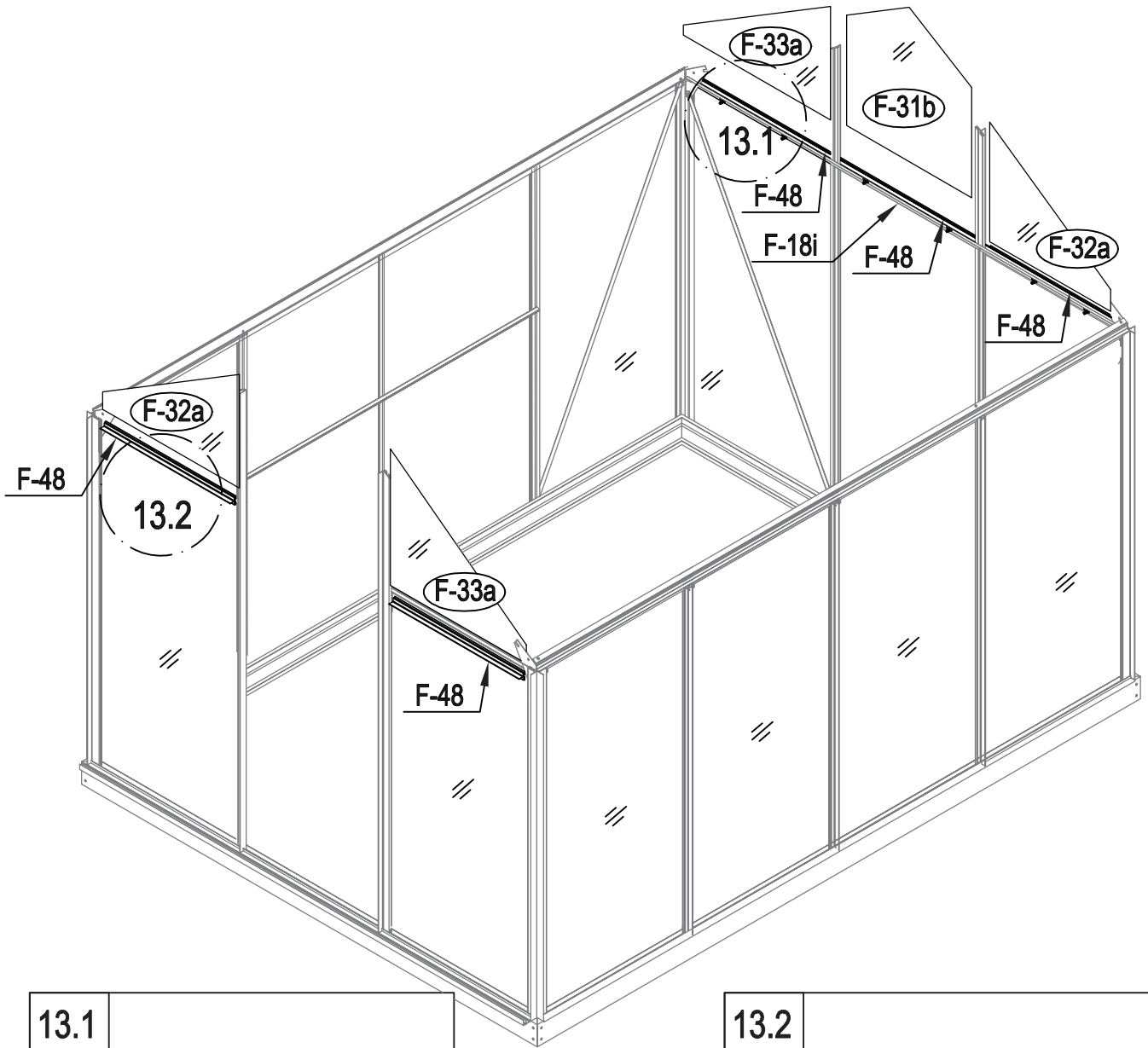

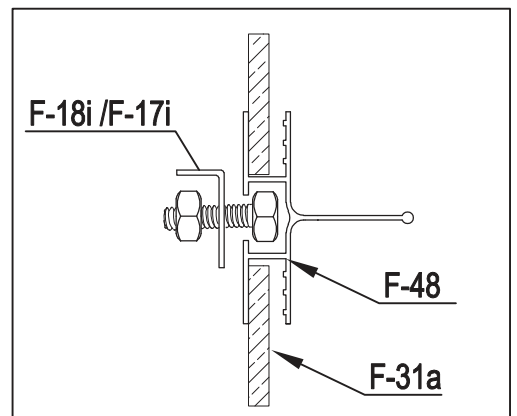

	F-31b	1
	F-32a	2
	F-33a	2
	F-48	5
	F-C14	10

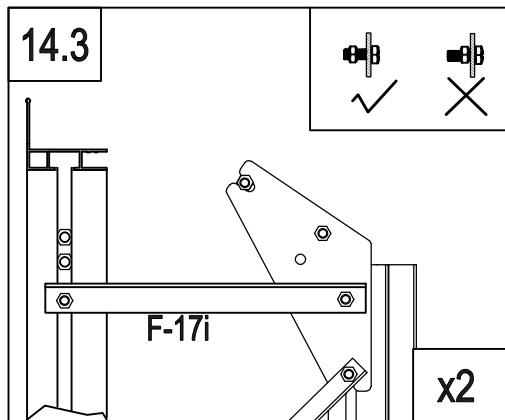
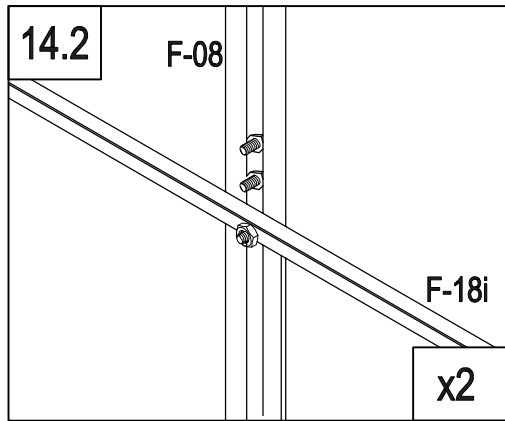
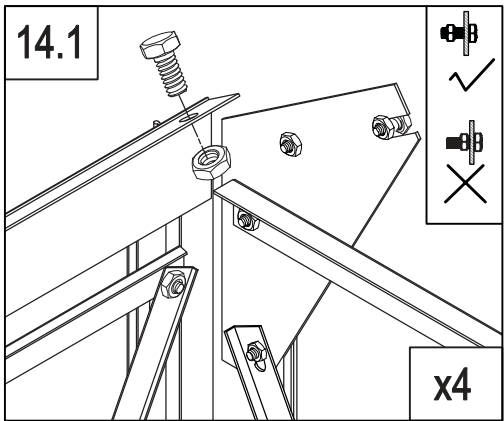
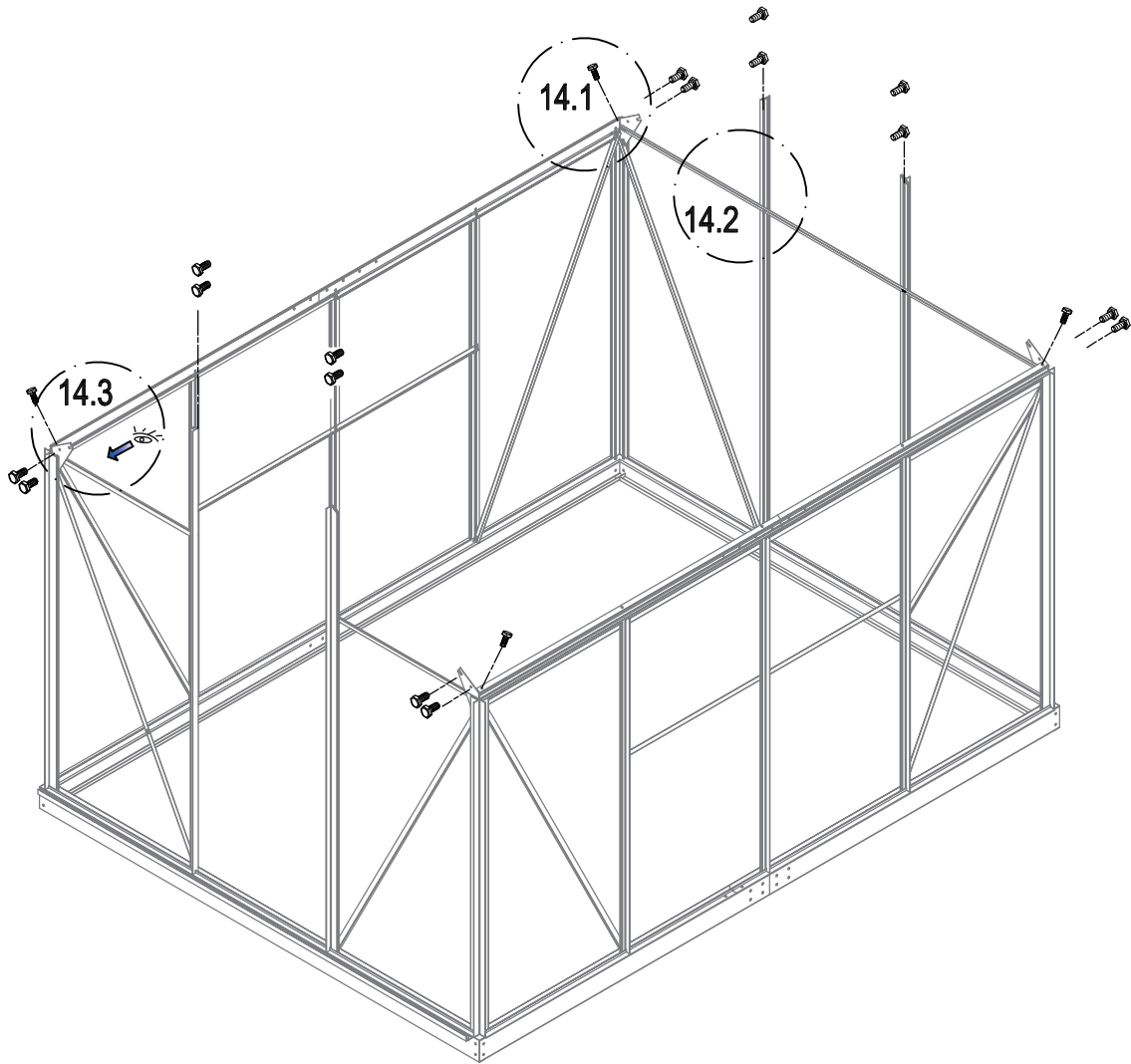

13



	F-C14	20
---	-------	----

14

15.1

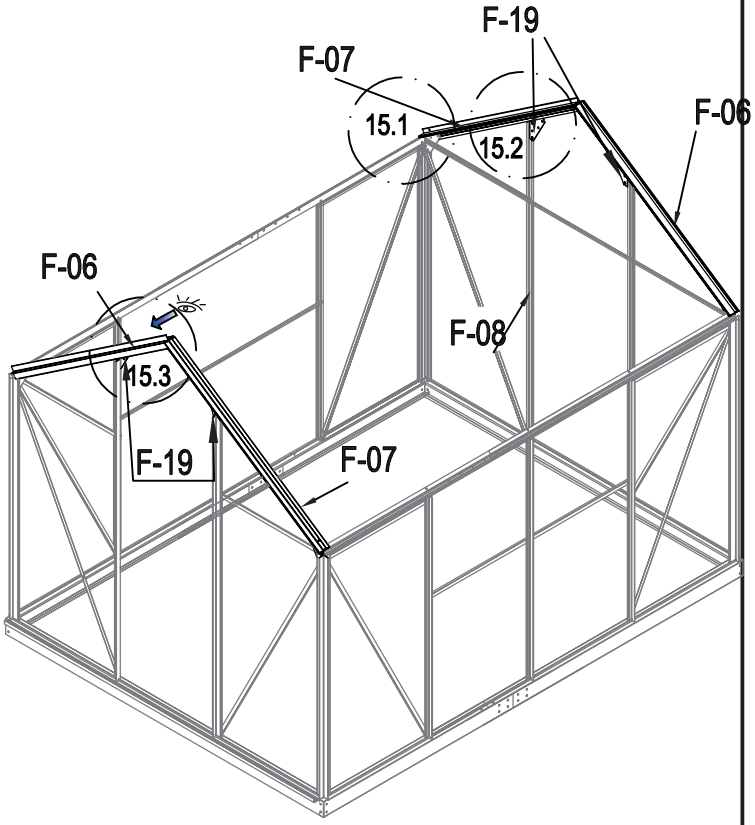
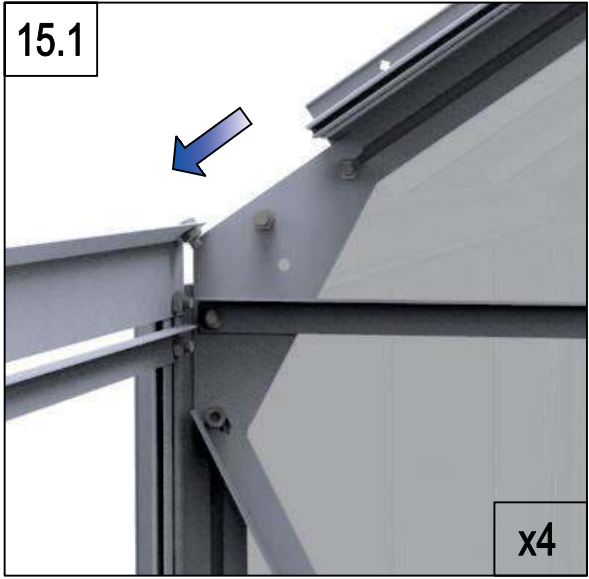

15.1



15.2



15.3

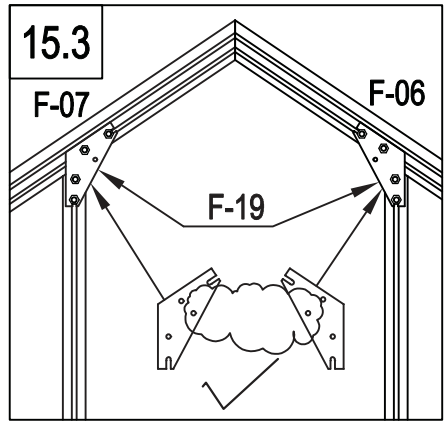

15.3

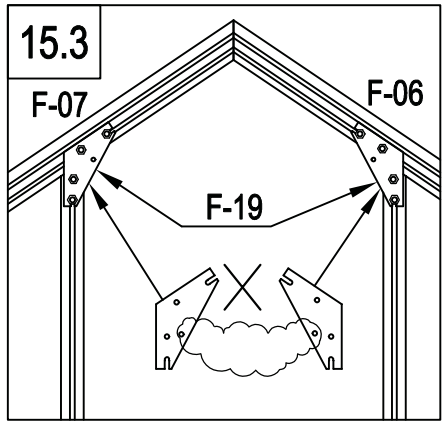

	F-06	2
	F-07	2
	F-19	4
	F-C14	8

15

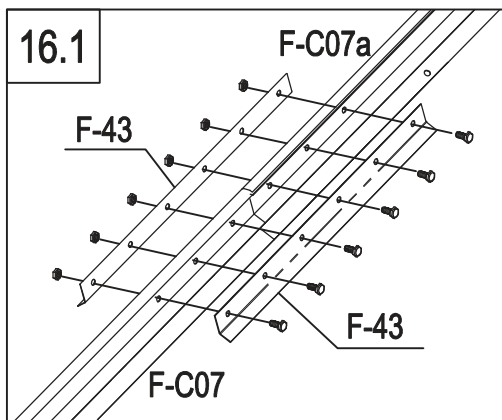
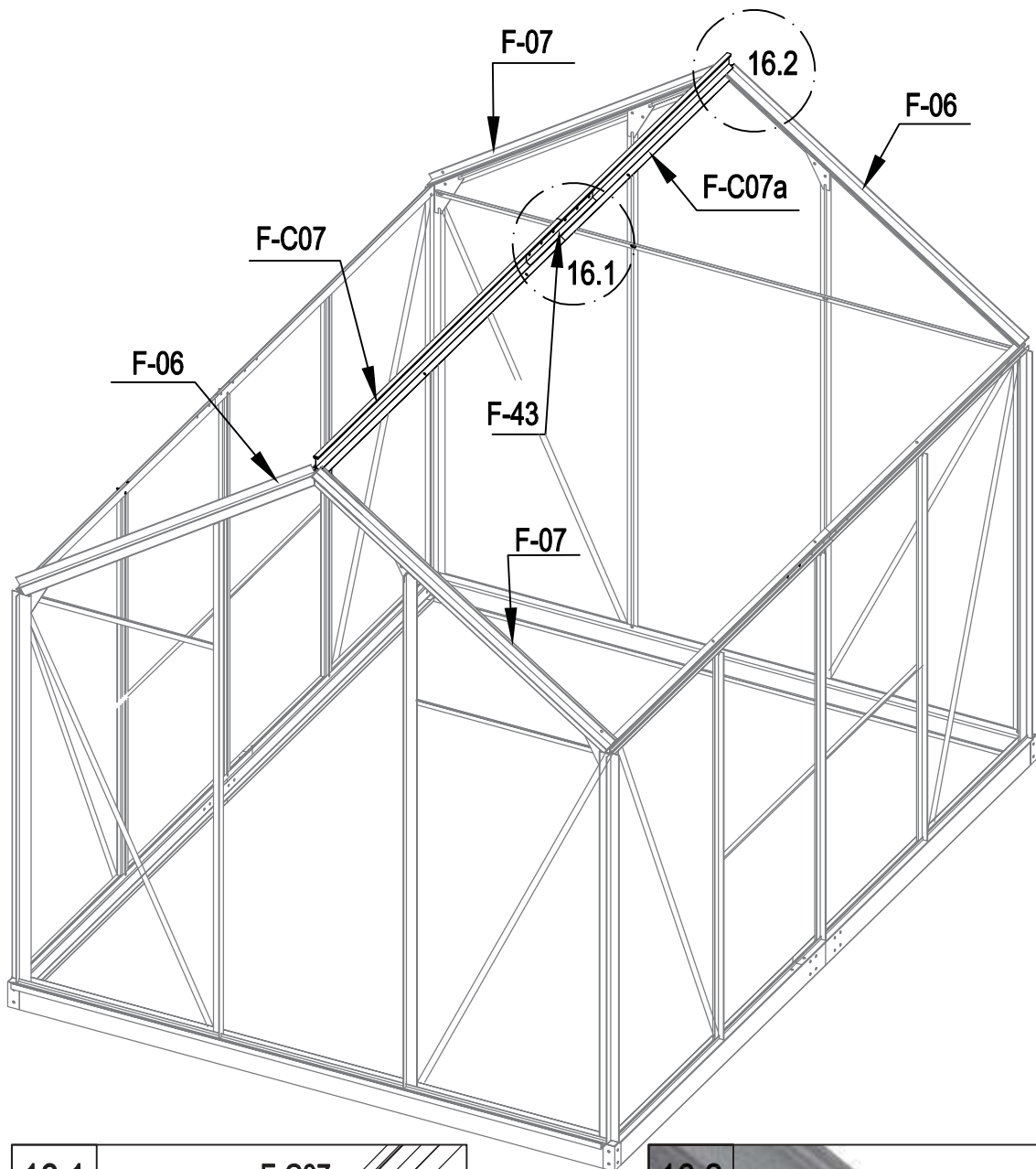

	F-C07	1
	F-C07a	1
	F-43	2
	F-C14	10

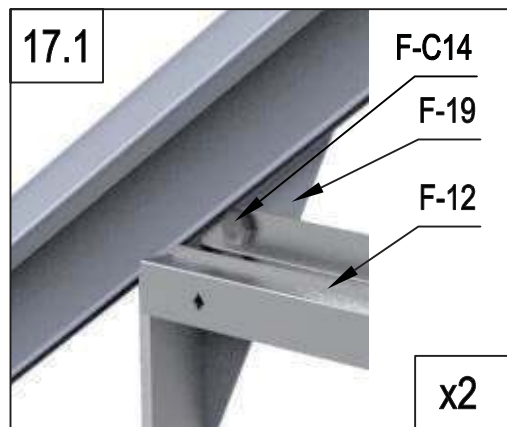
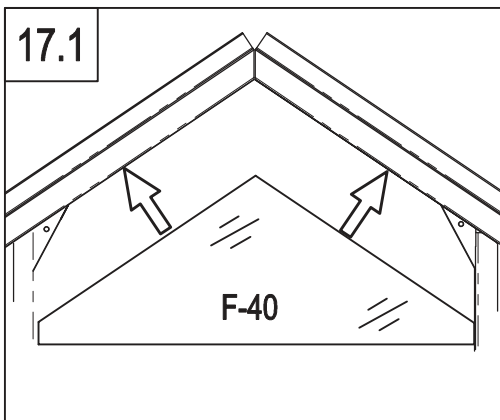
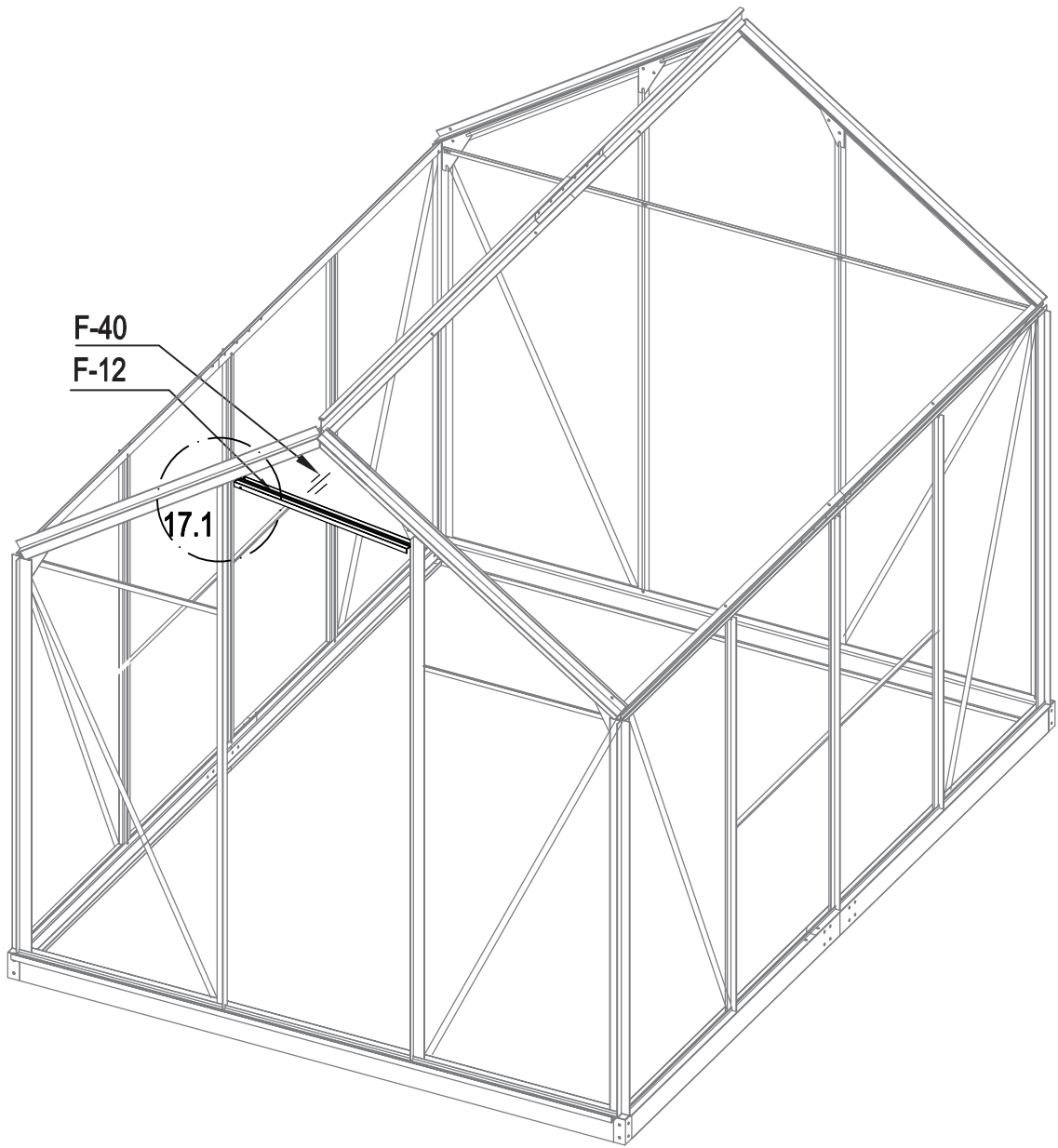

16

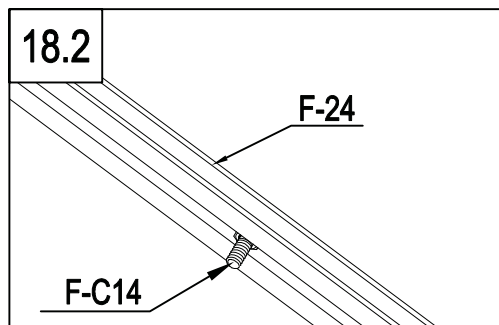
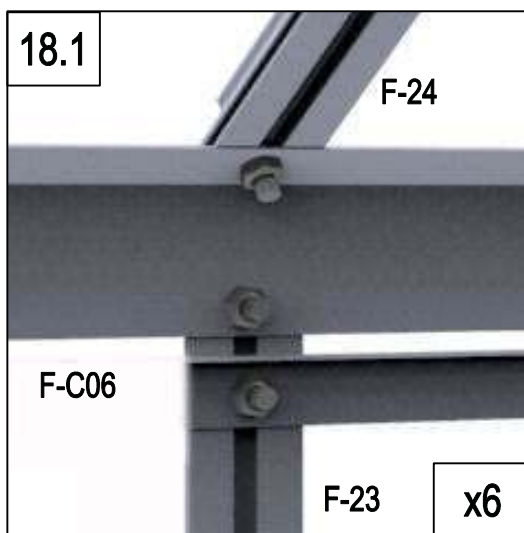
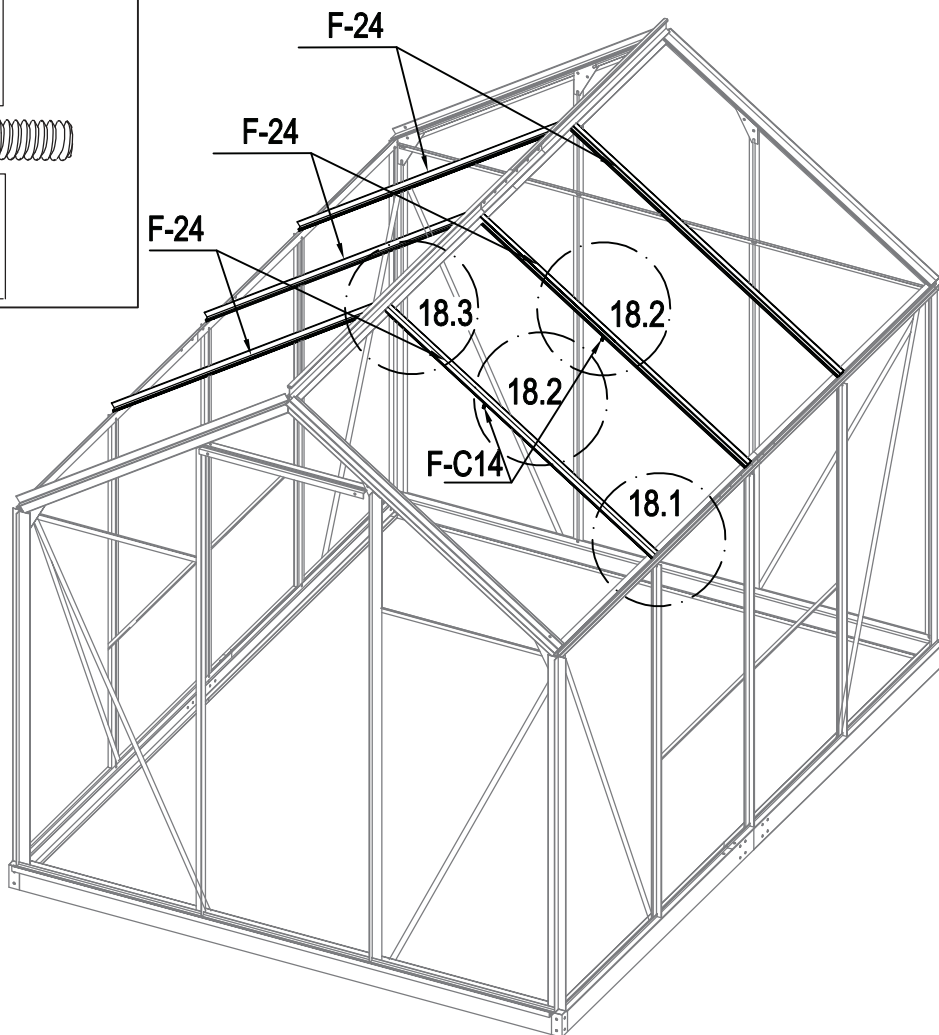
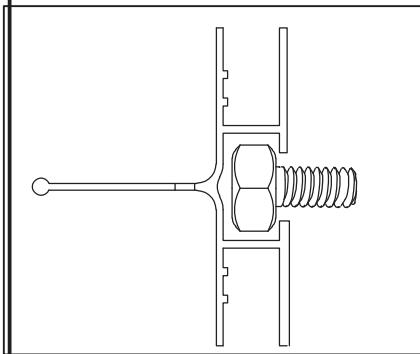

	F-12	1
	F-40	1
	F-C14	2

17

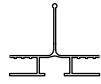

	F-24	6
	F-C14	14

18

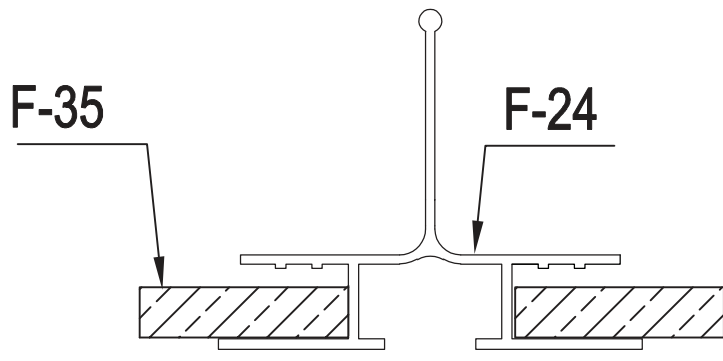
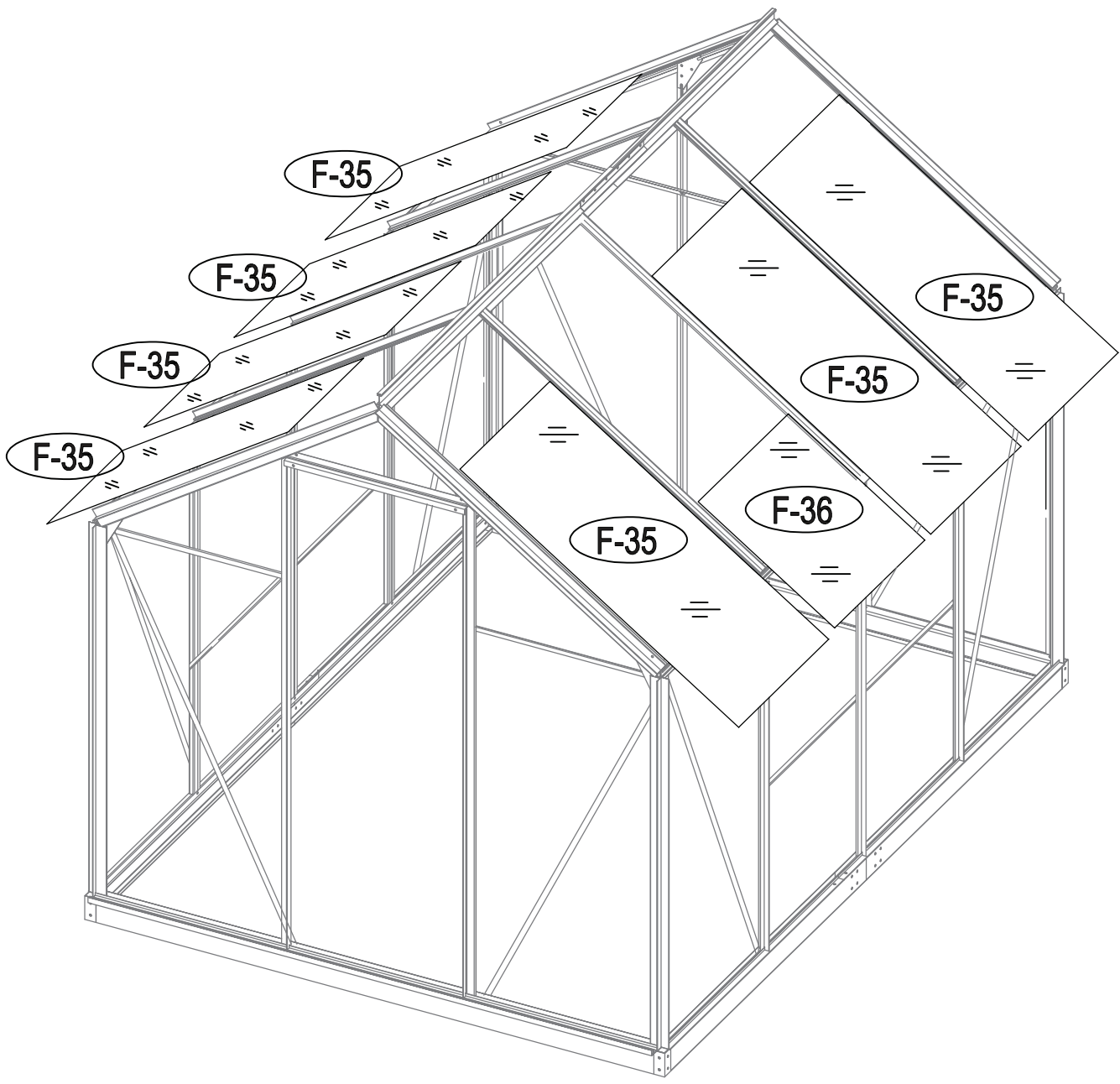

	F-36	1
	F-35	7

19

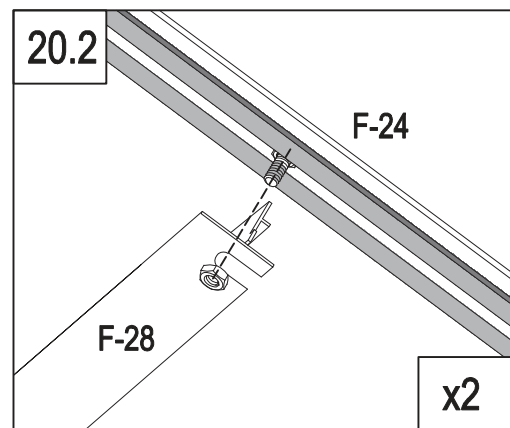
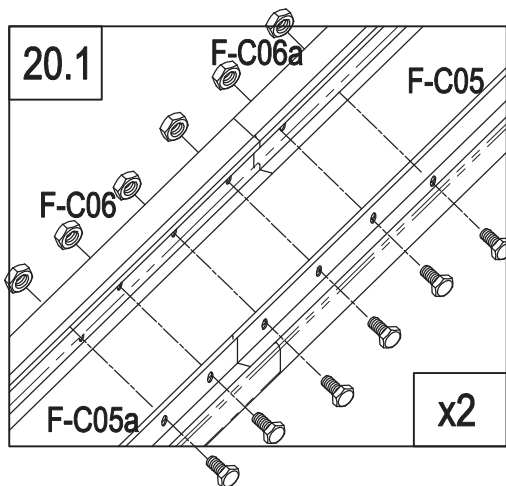
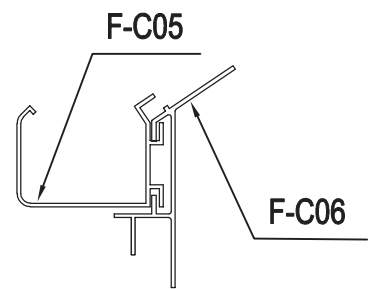
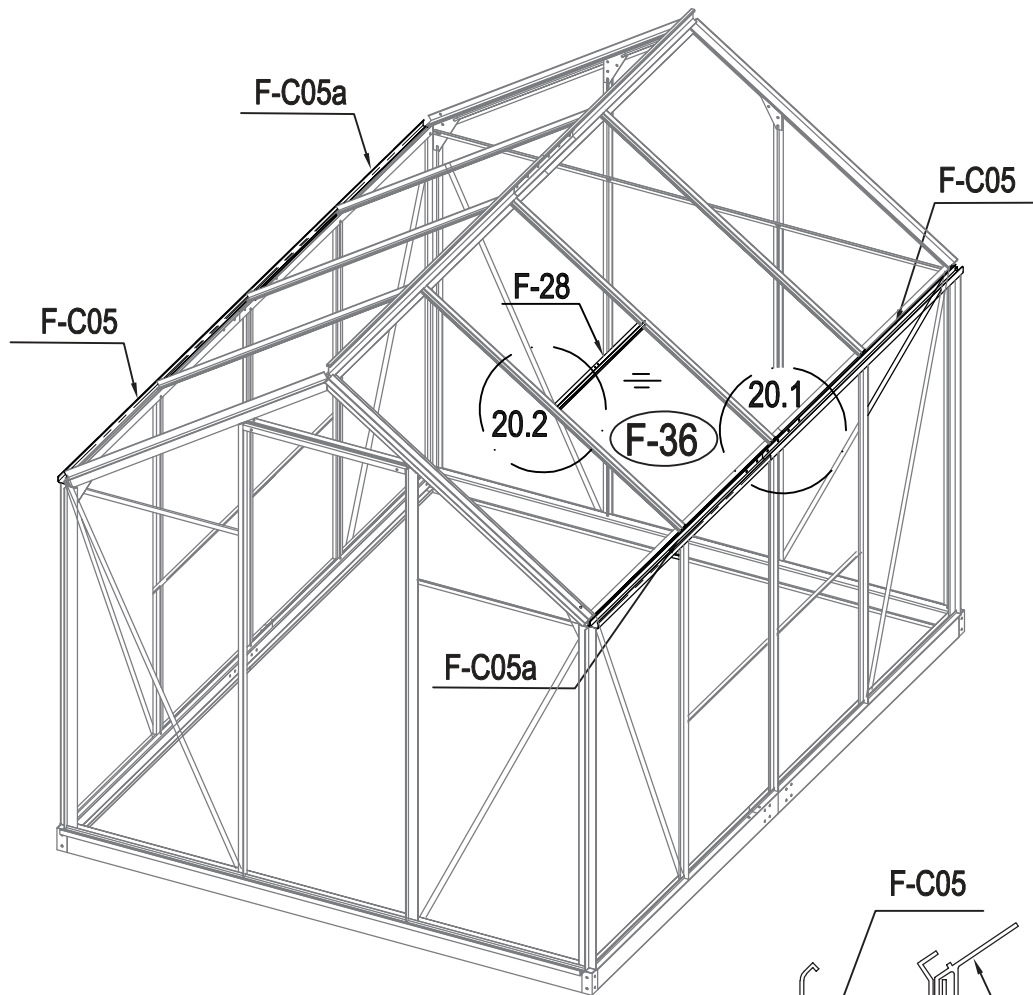

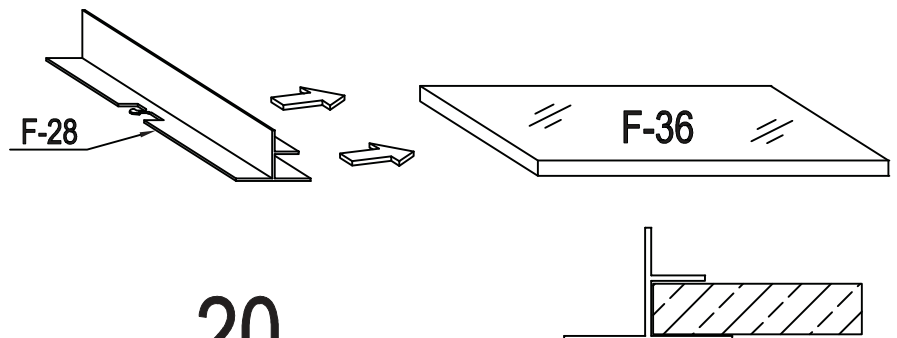

	F-28	1
	F-C05	2
	F-C05a	2
	F-C14	12

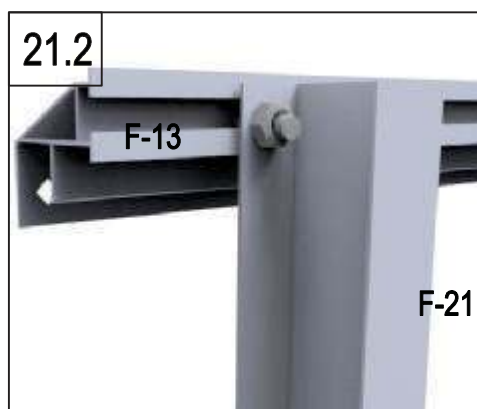
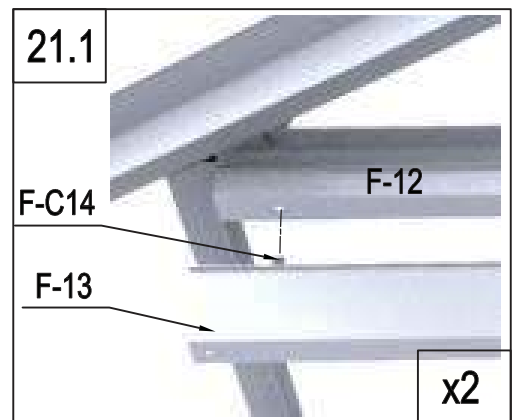
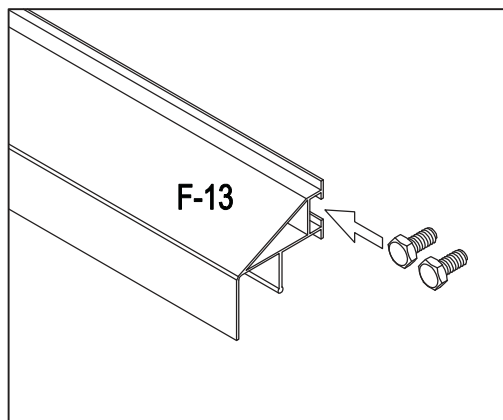
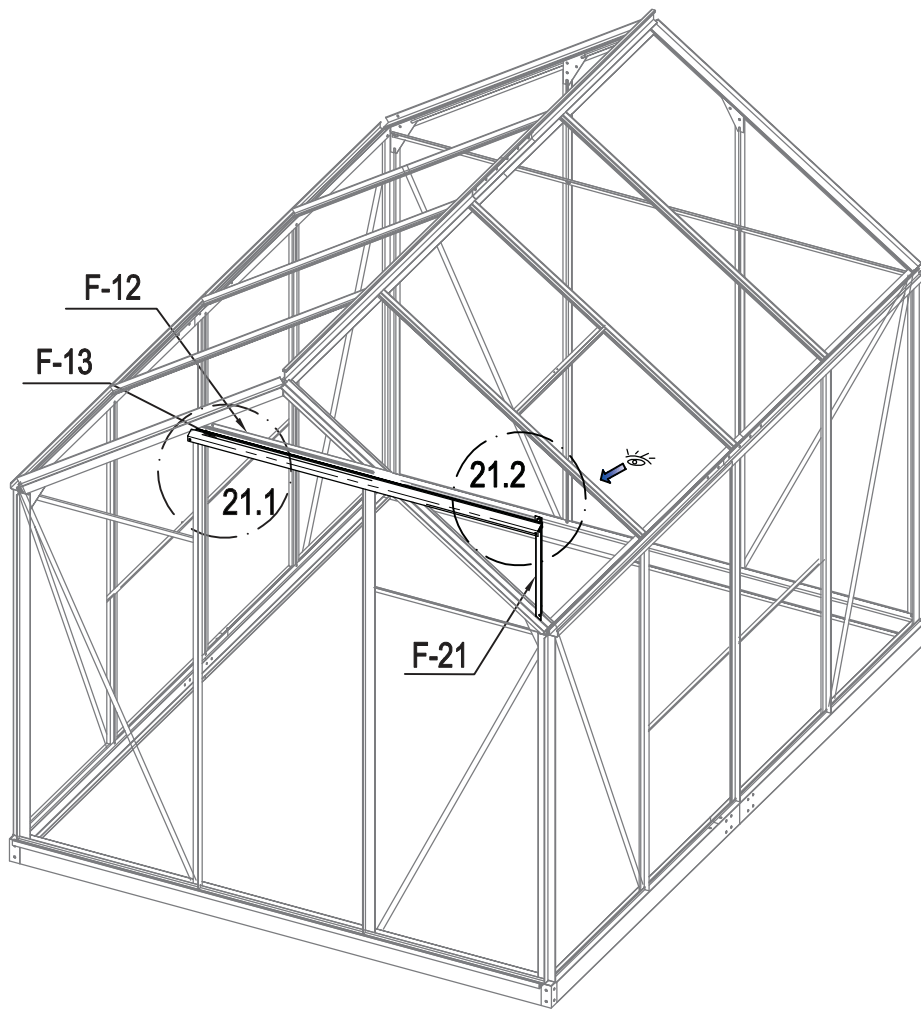

20



	F-13	1
	F-21	1
	F-C14	4

21

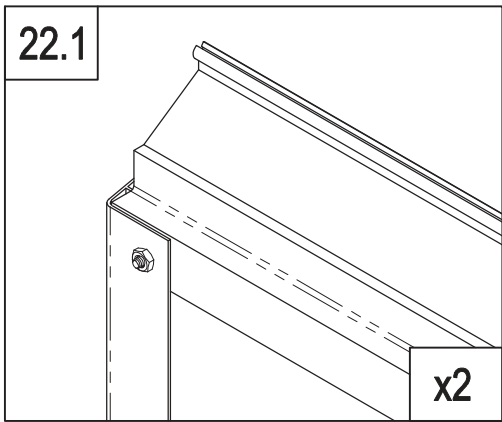
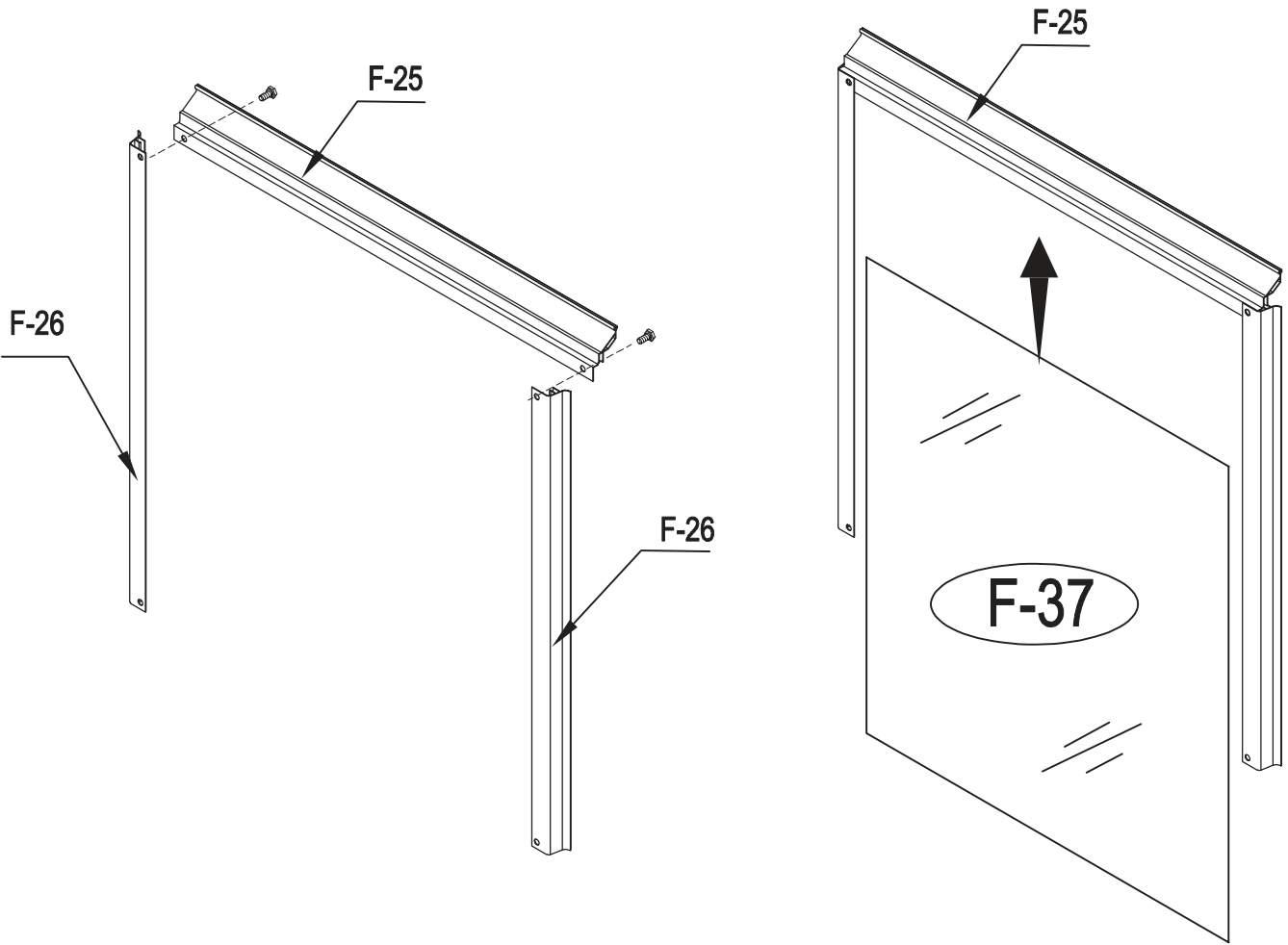

	F-25	1
	F-26	2
	F-37	1
	F-C14	2

22

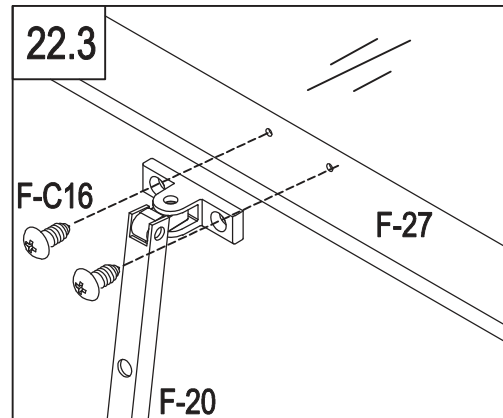
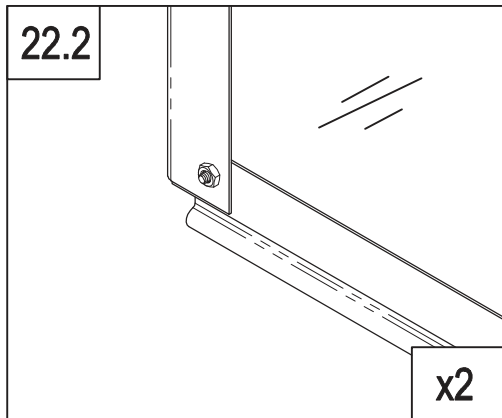
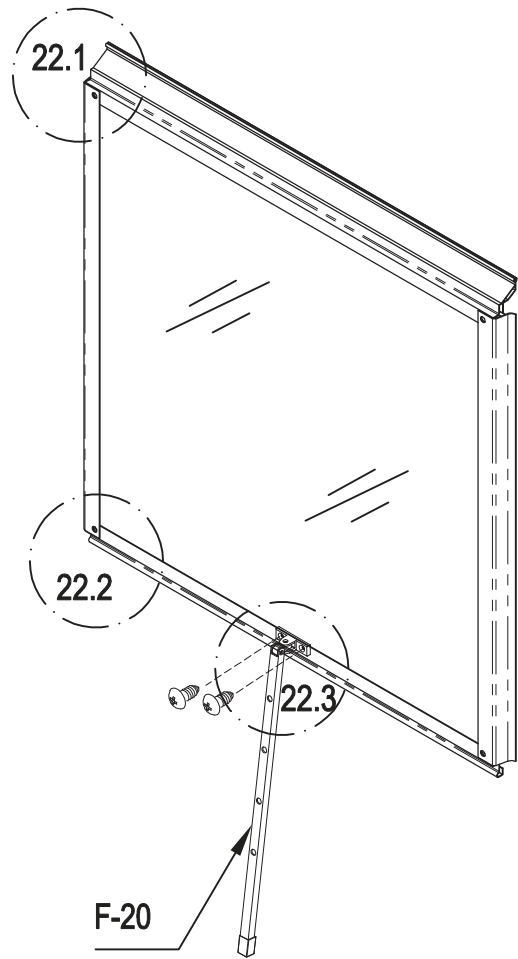
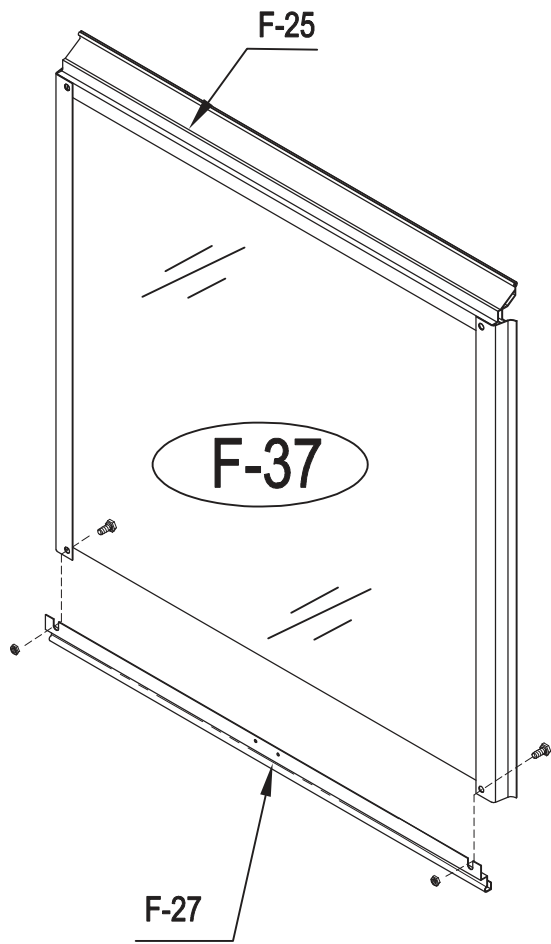

	F-27	1
	F-20	1
	F-C16	2
	F-C14	2

23

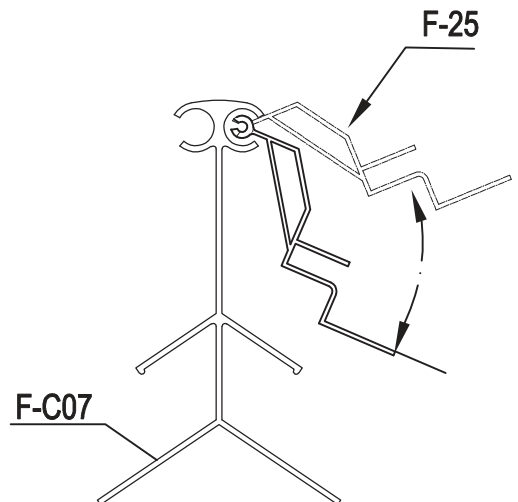
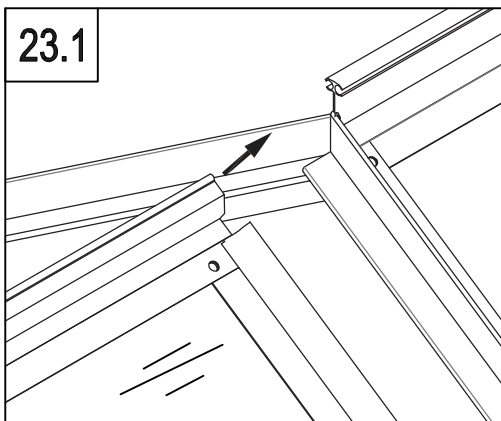
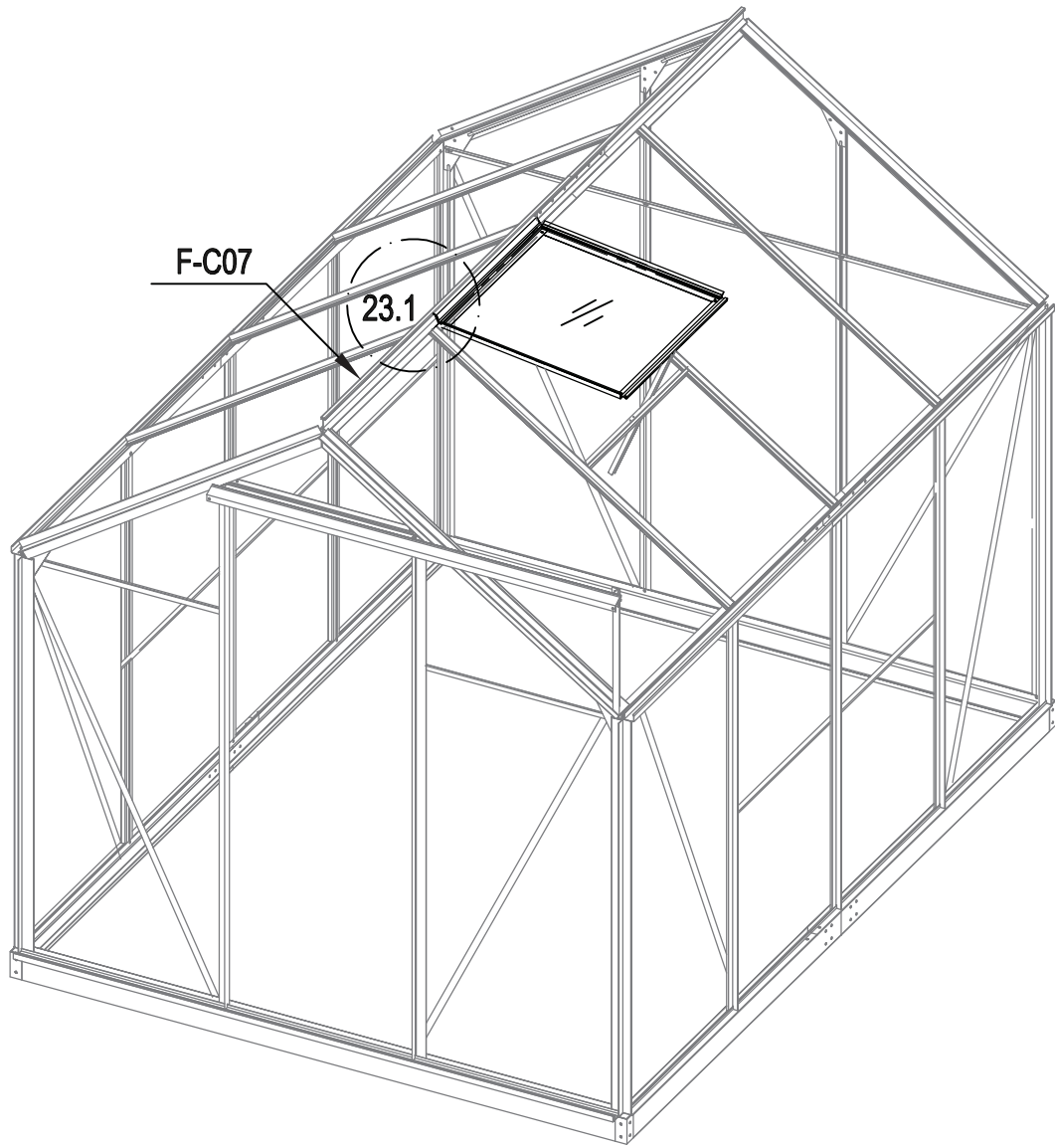

24

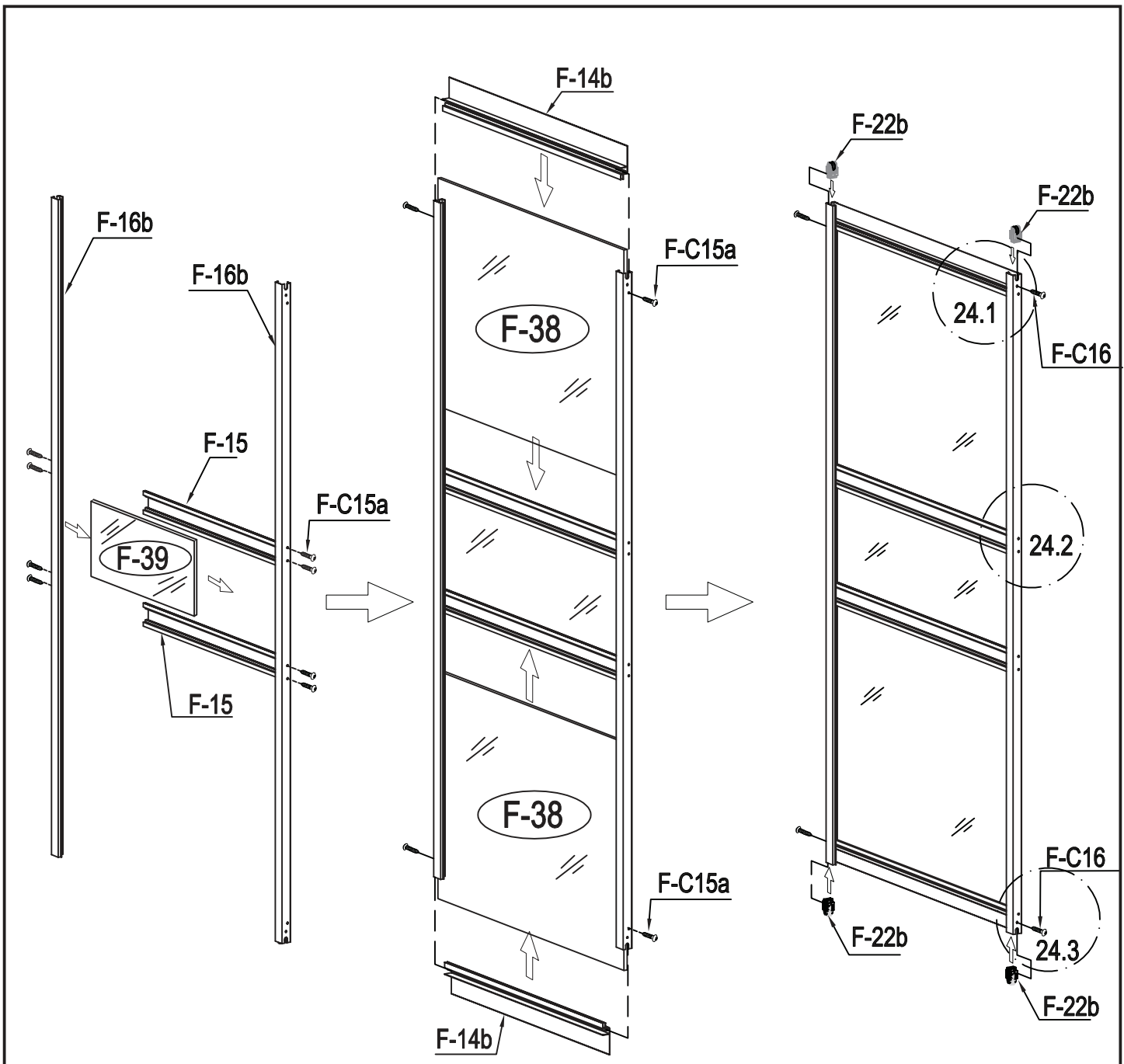

	F-38	2
	F-39	1
	F-16b	2
	F-14b	2
	F-15	2
	F-22b	4
	F-C15a	12
	F-C16	4

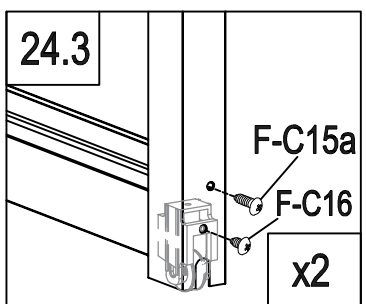
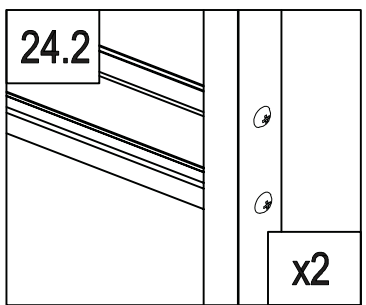
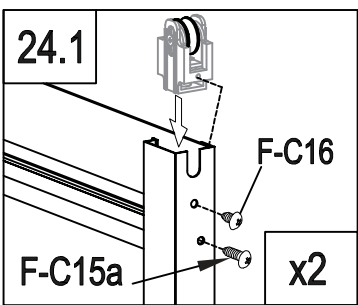

25

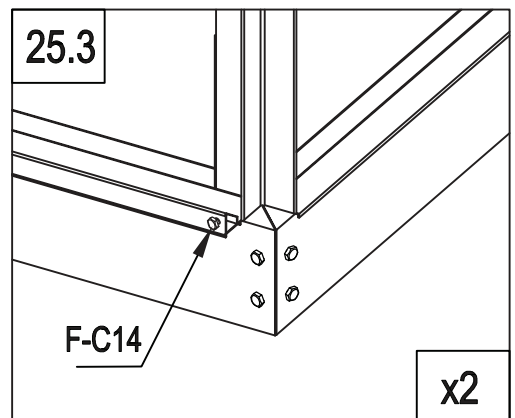
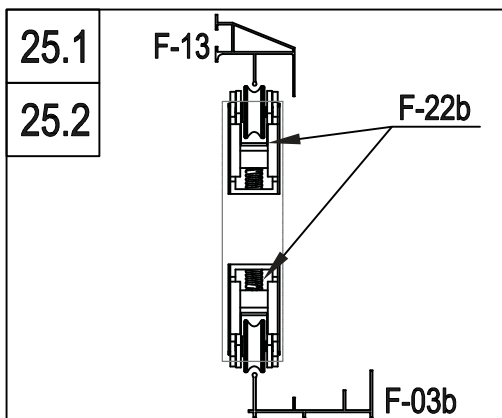
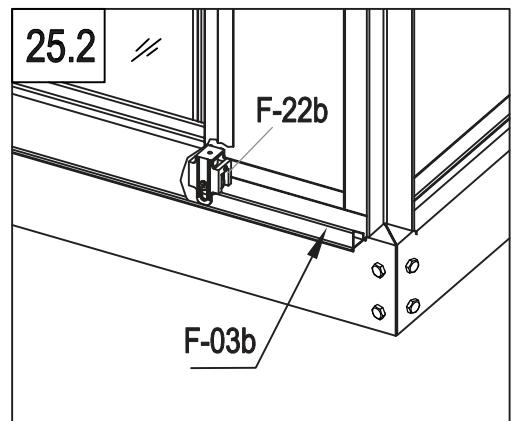
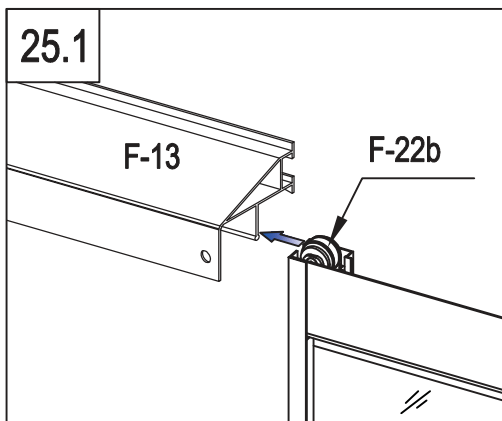
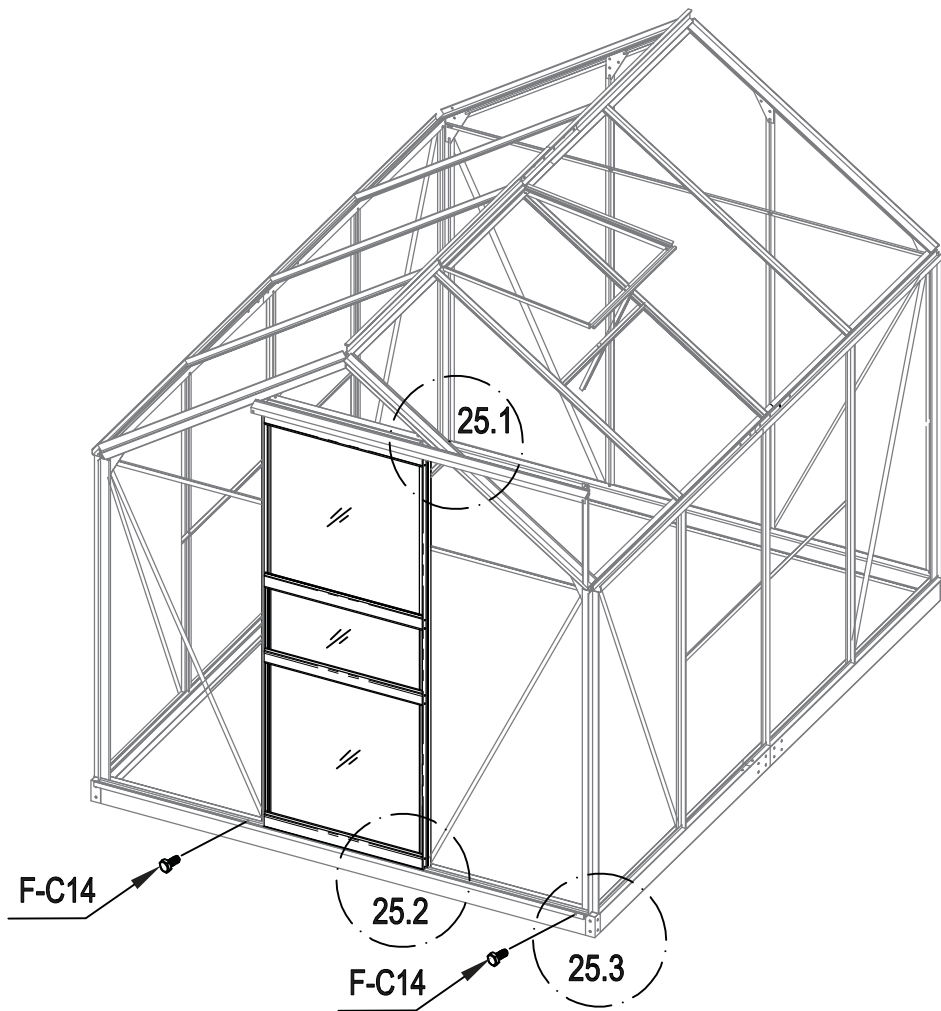

	F-C14	2
---	-------	---

26

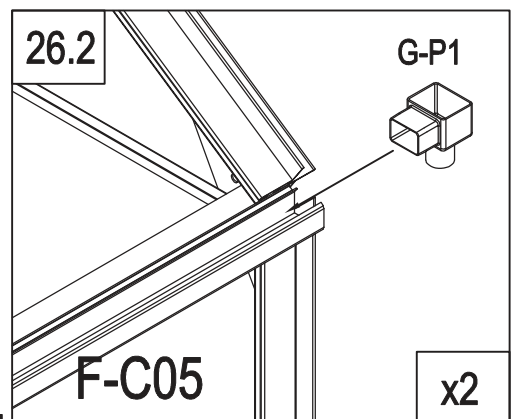
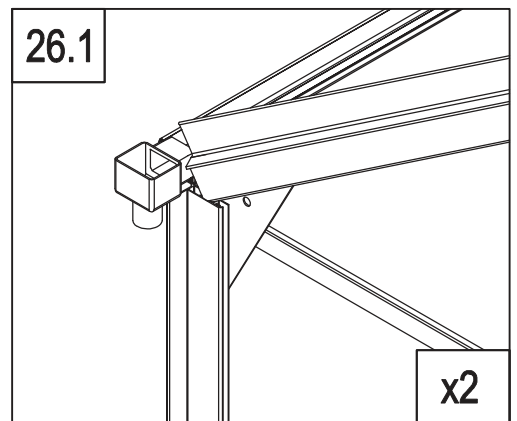
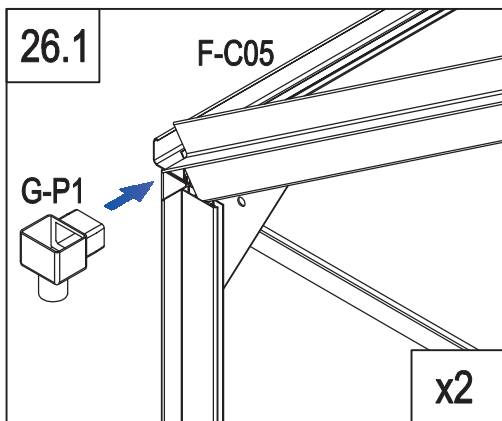
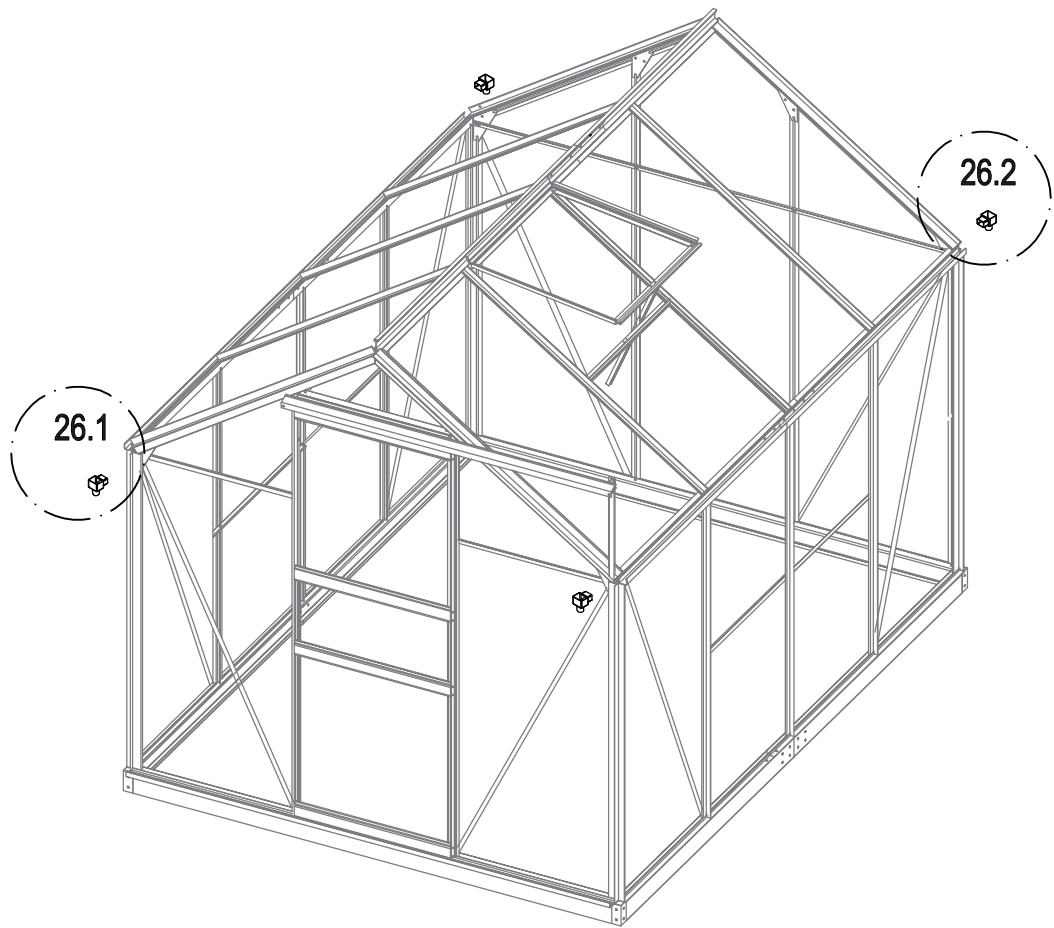

	G-P1	4
---	------	---

27

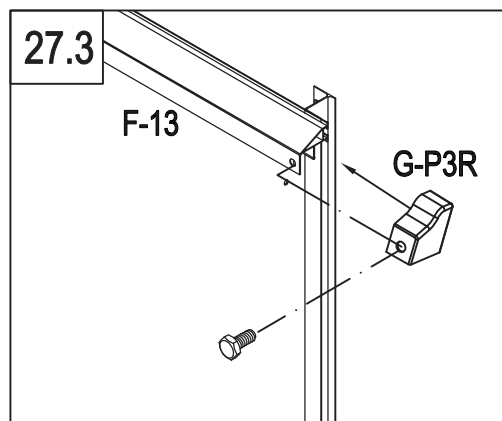
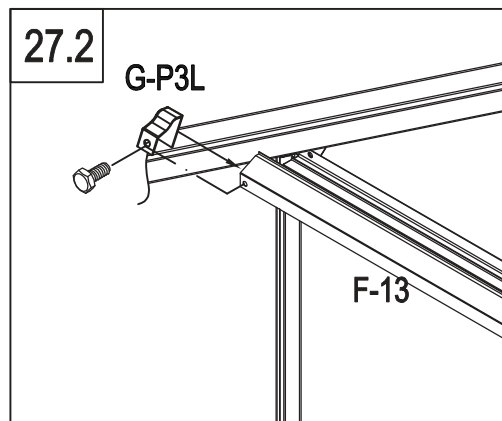
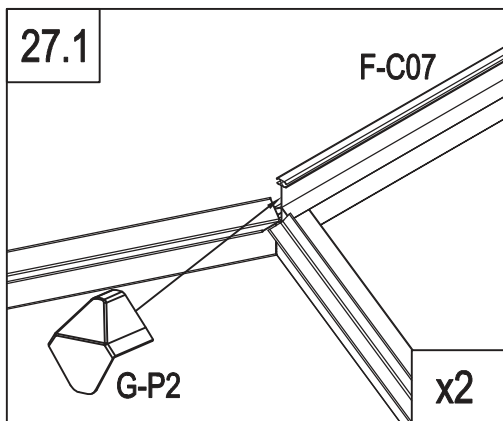
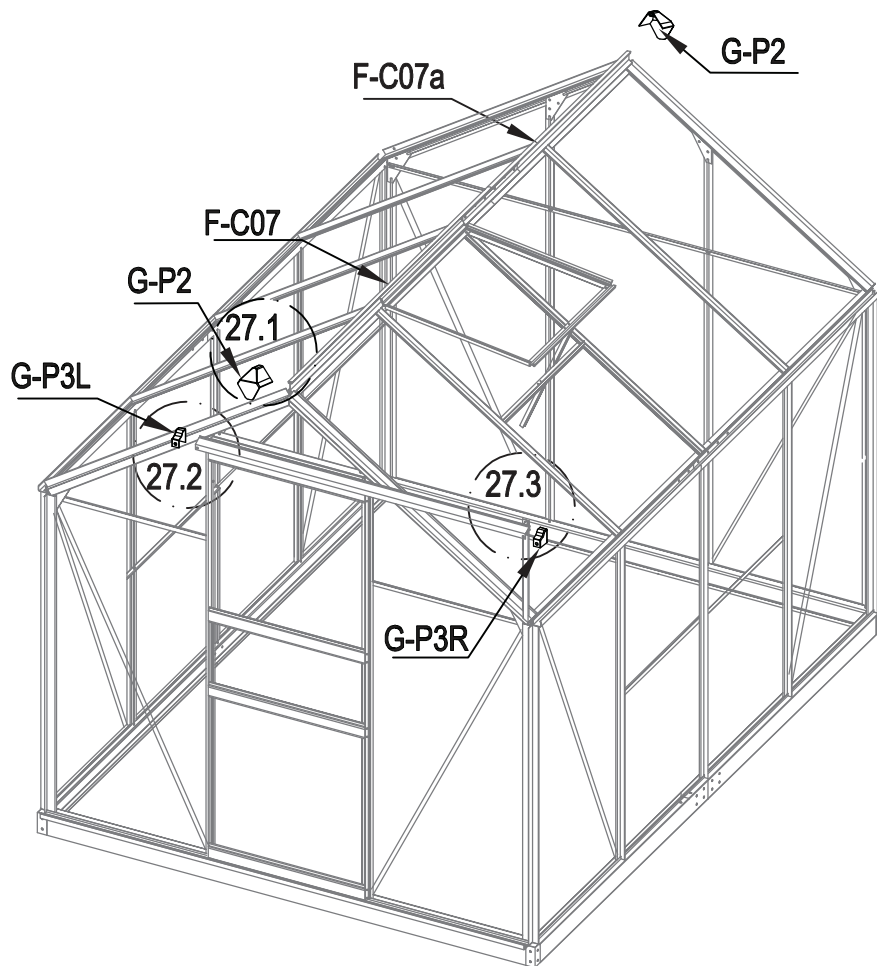

	G-P2	2
	G-P3L	1
	G-P3R	1
	F-C14	2

28

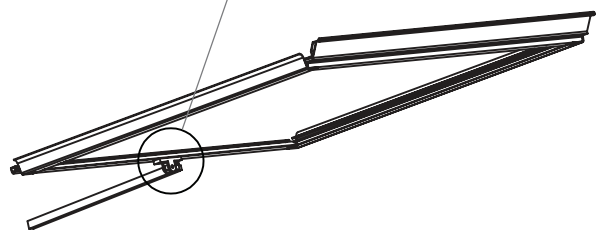
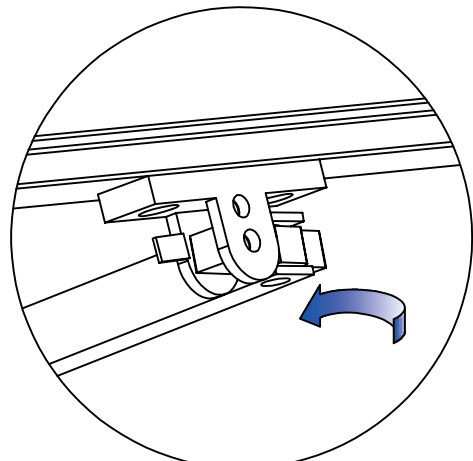
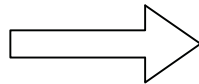
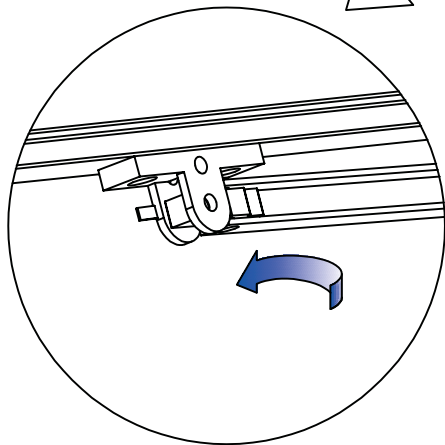
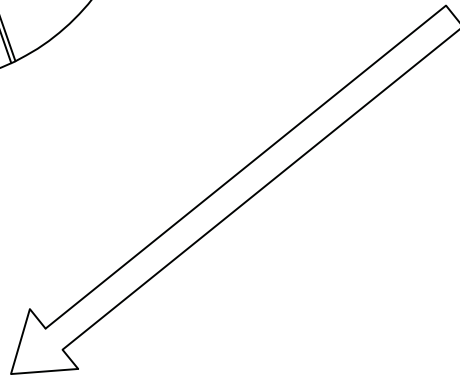
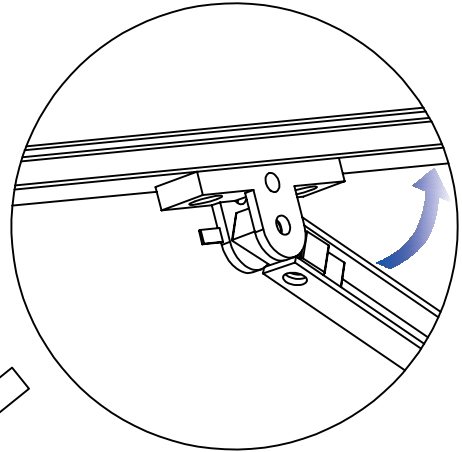
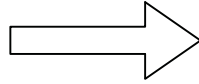
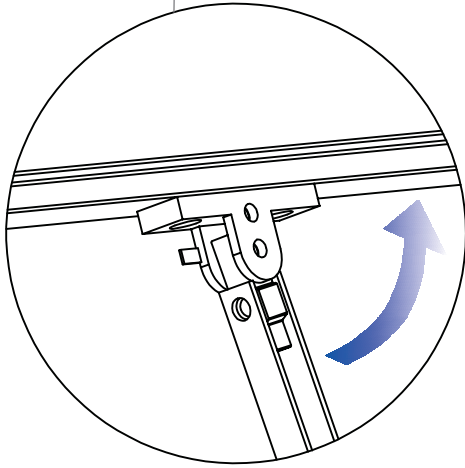
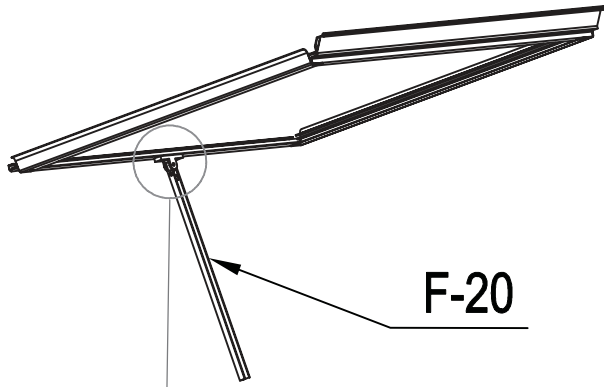

29

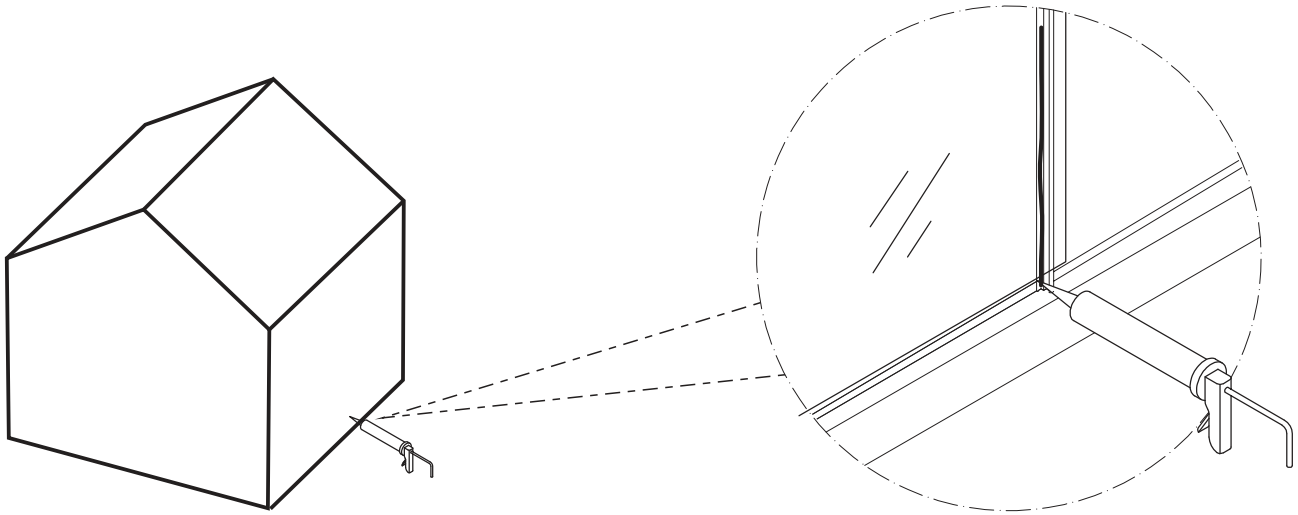

EN_ADVICE

It is not necessary but we would advise: For additional strength, you can also use some glue or tapes between the polycarbonate panel and the aluminium frame to enhance the stability.

Note: Silicone sealant and glue gun are not included in our tool kit. You can buy them locally. Only use silicone sealant suitable for aluminium

FR_CONSEILS

Ce n'est pas nécessaire mais nous vous conseillons:

Pour plus de solidité, vous pouvez également utiliser de la colle ou des rubans adhésifs entre le panneau en polycarbonate et le cadre en aluminium pour améliorer la stabilité.

Not : Le mastic silicone et le pistolet à colle ne sont pas inclus dans notre kit d'outils. Vous pouvez les acheter sur place. N'utilisez que du mastic silicone adapté à l'aluminium

ES_CONSEJO

No es necesario, pero le aconsejamos: Para mayor resistencia, también puede usar pegamento o cintas entre el panel de policarbonato y el marco de aluminio para mejorar la estabilidad.

Nota: El sellador de silicona y la pistola de pegamento no están incluidos en nuestro kit de herramientas. Puede comprarlos localmente. Sólo utilice el sellador de silicona adecuado para aluminio

DE_RAT

Es ist nicht notwendig, aber wir würden vorschlagen: Um die Festigkeit zu erhöhen, können Sie auch etwas Kleber oder Klebeband zwischen der Polycarbonatplatte und dem Aluminiumrahmen verwenden, um die Stabilität zu verbessern.

Hinweis: Silikonichtmittel und Klebepistole sind nicht in unserem Werkzeugsatz enthalten. Sie können sie vor Ort kaufen. Verwenden Sie nur für Aluminium geeignetes Silikonichtmittel



IT_SUGGERIMENTI

Non è necessario ma consigliamo: Per una maggiore resistenza, puoi anche usare della colla o dei nastri tra il pannello in polycarbonato e la struttura in alluminio per migliorare la stabilità.

Nota: il sigillante siliconico e la pistola per colla non sono inclusi nel nostro kit di attrezzi.

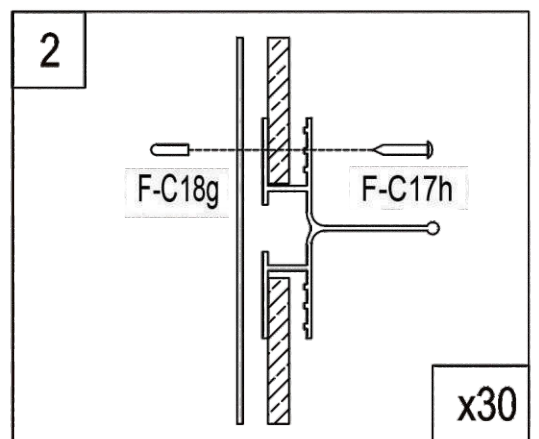
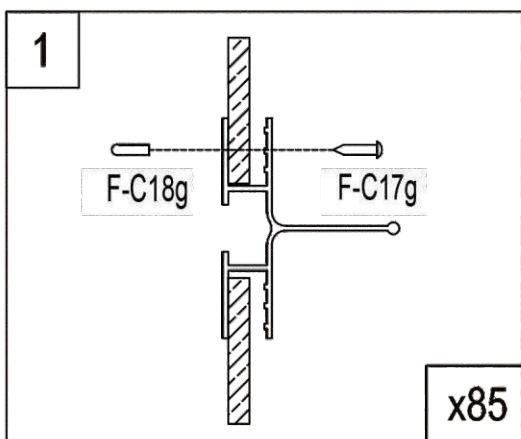
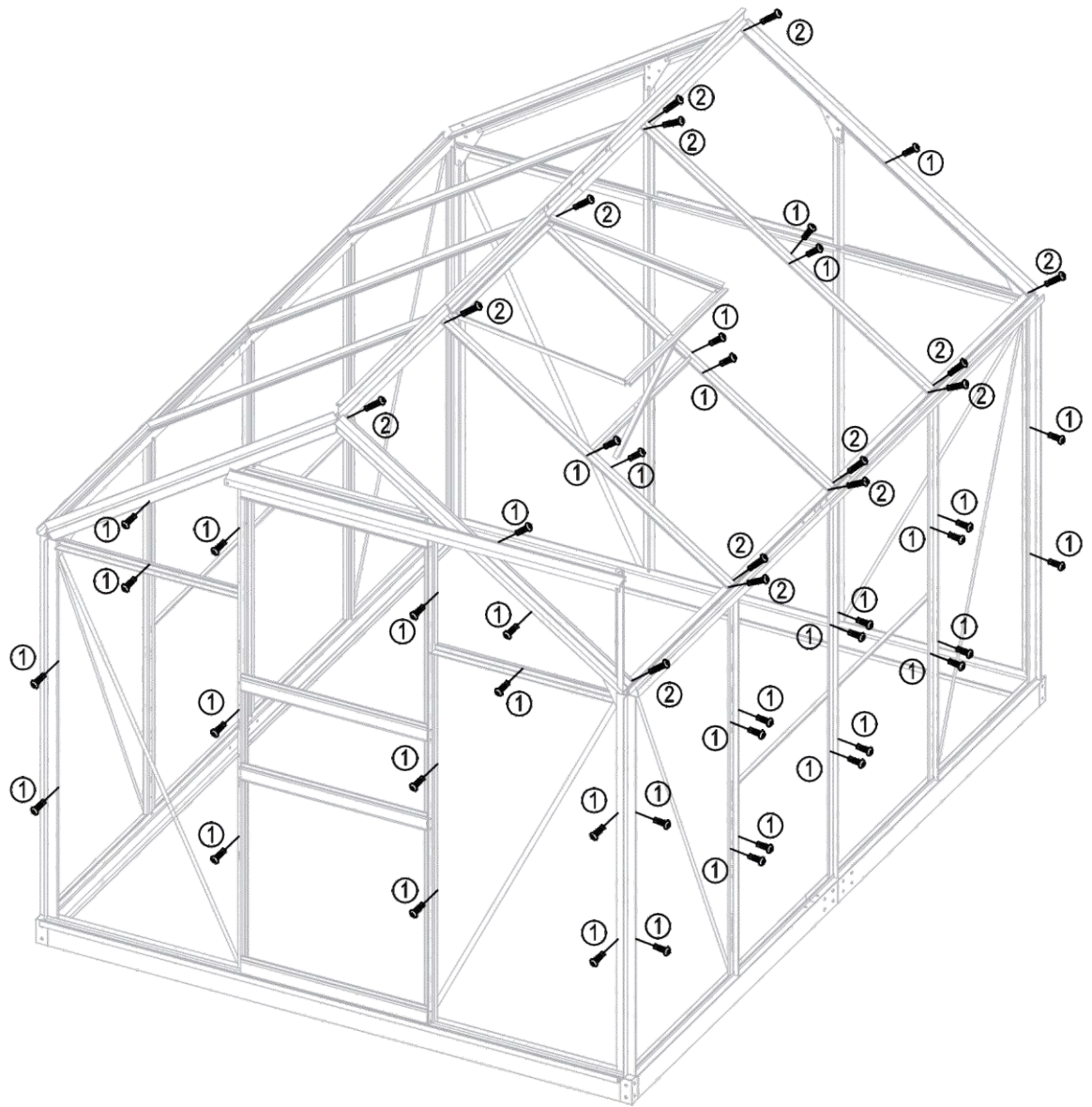
Puoi acquistarli localmente. Utilizzare solo sigillante siliconico adatto per alluminio.



	F-C18g	115
	F-C17g	85
	F-C17h	30

EN_It is not necessary but we would advise:

For additional strength, especially in the area with the strong wind weather, you can also drill the screws between the polycarbonate and the aluminum frame to enhance the stability.

FR_Ce n'est pas nécessaire mais nous vous conseillons:

Pour plus de solidité, en particulier dans les zones où le vent est fort, vous pouvez également percer les vis entre le polycarbonate et le cadre en aluminium pour améliorer la stabilité.

ES_No es necesario, pero le aconsejamos:

Para mayor resistencia, especialmente en el área con viento fuerte, también puede perforar los tornillos entre el policarbonato y el marco de aluminio para mejorar la estabilidad.

DE_Es ist nicht notwendig, aber wir würden vorschlagen:

Um die Festigkeit zu erhöhen, insbesondere in Gebieten mit starkem Wind, können Sie auch die Schrauben zwischen dem Polycarbonat und dem Aluminiumrahmen bohren, um die Stabilität zu verbessern.

IT_Non è necessario ma consigliamo:

Per una maggiore resistenza, soprattutto nella zona con vento forte, potete forare e serrare le viti tra il policarbonato e la struttura in alluminio per migliorare la stabilità.

If you have any questions, please contact our customer care center, Our contact details are below:

US

 001-877-644-9366

 customerservice@aosom.com

Imported by Aosom LLC
27150 SW Kinsman Rd Wilsonville, OR 97070 USA
MADE IN CHINA

If you have any questions, please contact our customer care center, Our contact details are below:

CA

 416-792-6088

 customerservice@aosom.ca

Imported by Aosom Canada Inc.
7270 Woodbine Avenue, Unit 307, Markham,
Ontario Canada L3R 4B9
MADE IN CHINA

Si vous avez la moindre question, veuillez contacter notre centre d'assistance à la clientèle, Nos coordonnées sont les suivantes:

 416-792-6088

 customerservice@aosom.ca

Importé par Aosom Canada Inc.
7270 Woodbine Avenue, unité 307,
Markham, Ontario Canada L3R 4B9
FABRIQUÉ EN CHINE

If you have any questions, please contact our customer care center, Our contact details are below:

UK

 0044-800-240-4004

 enquiries@mhstar.co.uk

IMPORTER ADDRESS:
MH STAR UK LTD
Unit 27, Perivale Park,
Horsenden lane South
Perivale, UB6 7RH
MADE IN CHINA

Si vous avez la moindre question, veuillez contacter notre centre d'assistance à la clientèle, Nos coordonnées sont les suivantes:

FR

 0033-1-84166106

 aosom@mhfrance.fr

Importé par/Fabricant/REP:
MH FRANCE
2 Rue Maurice Hartmann
92130 Issy Les Moulineaux
France
FABRIQUÉ EN CHINE

Wenn Sie Fragen haben, wenden Sie sich bitte an unser Kundendienstzentrum, Unsere Kontaktdaten stehen unten:

DE

 0049-0(40)-88307530

 service@aosom.de

ADRESSE DES IMPORTEURE/Hersteller/REP:
MH Handel GmbH
Wendenstraße 309
D-20537 Hamburg
Germany
IN CHINA HERGESTELLT

In caso di dubbio, si prega di contattare il nostro centro assistenza clienti, I nostri dettagli di contatto sono di seguito:

IT

 0039-0249471447

 clienti@aosom.it

IMPORTATO DA/Produttore/REP:
AOSOM Italy srl
Centro Direzionale Milanofiori
Strada 1 Palazzo F1
20057 Assago (MI)
P.I.: 08567220960
FATTO IN CINA

Si tiene alguna pregunta, comuníquese con nuestro Centro de Atención al Cliente, Nuestros datos de contacto son los siguientes:

ES

 0034-931294512

 atencioncliente@aosom.es

IMPORTADOR/Fabricante/REP:
SPANISH AOSOM, S.L.
C/ROC GROS, N°15.08550, ELS HOSTALETES DE
BALENYÀ, SPAIN.
B66295775
HECHO EN CHINA

Se tiver alguma dúvida, por favor contacte o nosso Centro de Atendimento ao Cliente, Os nossos dados de contacto são os seguintes:

PT

 0034-931294512

 info@aosom.pt.

IMPORTADOR/Fabricante/REP:
SPANISH AOSOM, S.L.
C.ROC GROS N.15, 08550. ELS HOSTALETES DE
BALENYÀ
FEITO NA CHINA



FR

**DONNEZ
OU
RECYCLEZ**



ASSOCIATION

OU



LIVRAISON

OU



DÉCHÈTERIE

Adresses sur quefairedemesdechets.fr