



IN221001979V01_UK

370-188V70



Battery Operated Tricycle

*Suitable for children of 18-36 months.

*Max weight: 25 kg.



IMPORTANT, RETAIN FOR FUTURE REFERENCE: READ CAREFULLY

ASSEMBLY INSTRUCTION

Specifications:	
Battery:	6V,4.5Ah*1
Motor:	6V,20W,#380*1
Suitable ages:	18-36 months
Maximum weight:	25 kg
Speed :	2Km/h
Power way:	Charging type
Use of time:	Charg: 8-12 hours ; Use: 1-2 hours
Charger:	Input AC 120~240V, 50/60Hz,0.2A ; output DC 6 V, 0.5A

WARNING

- 1.The pictures in this instruction is only for explaining the operation and structure of the product, when there's any difference with the real product, please confirm with the real product.
- 2.In order to improve the quality of the product,we may amend some structure or appearance of the product without notification.Thank you for your understanding.

FOR THE SAFETY OF YOUR CHILD, PLEASE READ ALL WARNINGS AND ASSEMBLY/USE INSTRUCTIONS. KEEP THIS GUIDE FOR FUTURE REFERENCE.

- ADULT ASSEMBLY REQUIRED. The product contains small parts, which are for adult assembly only. keep small children away when assembling.
- always remove protective material and poly bags and dispose before assembly.
- never leave child unattended. direct adult supervision is required.
- always keep child in view when child is in vehicle.
- Keep Children within Safe Riding Areas:
 - Never use in roadways, near motor vehicles, on lawn space, on or near steep inclines or steps, swimming pools or any other dangerous area.
- Use the toy only on flat surfaces. Such as inside your house, garden or playground.
- Never use in the dark. A child could encounter unexpected obstacles and have an accident. Operate the vehicle only in the daytime or a well-lit area.
- Please avoid running on sand or any other rough ground.
- always wear shoes.
- always sit on the seat.
- this toy has no brake.
- It is prohibited to change the circuit or add other electric parts
- Inspect wires and connections of the vehicle periodically.
- Do not let any child touch the wheels or be near them when the car is moving.
- This vehicle has adjustable play seat belts. Please instruct children how to tie the safety belt before using, guarantee the security.

STORAGE BATTERY INFORMATION AND MAINTENANCE

- Please charge 8 to 12 hours before first time use.
- Please use the suitable adapter to charge storage battery, otherwise the ride-on will be damaged.
- Please charge the car once the speed is slower than normal, otherwise it will decrease storage battery life.
- Please fully charge the battery before you put your ride-on away, and remember to recharge the battery every 30 days. This will ensure the normal use of the battery, otherwise, the battery might not hold a charge without proper maintenance.
- Batteries may leak fluids that can cause chemical burn injury or ruin your product.
- To avoid battery leakage: Do not mix old and new batteries or batteries of different types: alkaline, standard (carbon-zinc) or rechargeable (nickel-cadmium).
- Insert batteries as indicated inside the battery compartment. Remove batteries during long periods of non-use.
- Always remove exhausted batteries from the product. Dispose of batteries safely. Do not dispose of batteries in a fire. The batteries may explode or leak.
- Never short-circuit the battery terminals.
- Non-rechargeable batteries are not to be recharged.
- Use only batteries of the same or equivalent type as recommended.
- Do not charge non-rechargeable batteries.
- Remove rechargeable batteries from the product before charging.
- If removable rechargeable batteries are used, they are only to be charged under adult supervision
- Every single charging can not go over 10 hours. Both charger and storage batteries will occur mildly warm during charging. Do not use mal-functioned adapter or storage battery unless they are repaired.
- Charger and storage batteries are not considered as toys.
- Please make periodical inspection for storage battery, especially for adapter wires and plugs.
- Please turn off the switch when the ride-on is not in use. Please do a full charge after long periods of inactivity.
- Charge in well ventilated, dry place. Do not open the battery or the charger.
- Tighten the screws with a screwdriver. DO NOT over tighten

Disposal Of Battery:

1. Your sealed lead-acid battery must be recycled or disposed of in an environmentally sound manner.
2. Do not dispose of your lead-acid battery in a fire. The battery may explode or leak.
3. Do not dispose of a lead-acid battery in your regular, household trash. The incineration, land filling or mixing of sealed lead-acid batteries with house-hold trash is prohibited by law.

PREVENT FIRE AND ELECTRIC SHOCK:

- Use the only rechargeable battery and charger supplied with your vehicle.
 - NEVER substitute the battery or the charger with another brand. Using another battery or charger may cause a fire or explosion.
 - Do not use the battery or charger for any other product. Overheating, fire or explosion could occur.
 - NEVER modify the electric circuit system. Tampering with the electric system may cause a shock, fire or explosion or may permanently damage the system.
 - Do not allow direct contact between battery terminals. Fire or explosion can occur.
 - Do not allow any type of liquid on the battery or its components.
 - Explosive gasses are created during charging. Do not charge near heat or flammable materials. Charge the battery in a well- ventilated area ONLY.
 - NEVER pick up the battery by the wires or charger. Damage can occur to the battery and may cause a fire. Pick up the battery by the case ONLY.
- Charge the battery in a dry area ONLY.
- Battery posts, terminals and related accessories contain lead and lead compounds, chemicals known to the State of California to cause cancer and reproductive harm. Wash hands after handling.
 - Do not open the battery. Battery contains lead acid and other materials that are toxic and corrosive.
 - Do not open the charger. Exposed wiring and circuitry inside case may cause electric shock.
- ONLY adults may handle or charge the battery. NEVER allow child to handle or charge the battery. Battery is heavy and contains lead acid (electrolyte).
- Do not drop the battery. Permanent damage to the battery could occur or cause serious injury.
 - Before charging the battery, check for wear or damage to the battery, charger, its supply cord and the connectors. DO NOT charge the battery if any damage to parts has occurred.
- Do not allow the battery to drain completely. Recharge the battery after each use or once a month if not used regularly.
- Do not charge battery upside down.
 - Always secure the battery with the bracket. Battery can fall out and injure a child if vehicle tips over.
 - It is parents' responsibility to check main parts of the toy before using, Must regularly examine for potential hazard, such as the battery, charge, cable or cord, plug, screws are fastening enclosure of other parts and that in the event of such damage, the toy must not be until that damage had been properly removed. Make sure the plastic parts of the vehicle are not cracked or broken.
 - Occasionally use a lightweight oil to lubricate moving parts such as wheels.
 - Park the vehicle indoors or cover it with a tarp to protect it from wet weather.
 - Keep the vehicle away from sources of heat, such as stoves and heaters. Plastic parts may melt.
 - Recharge the battery after each use. Only an adult can handle the battery. Recharge the battery at least once a month when the vehicle Raider is not being used.
 - Do not wash the vehicle with a hose. Do not wash the vehicle with soap and water. Do not drive the vehicle in rainy or snowy weather. Water will damage the motor, electric system and battery.
 - Clean the vehicle with a soft, dry cloth. To restore shine to plastic parts, use a non-wax furniture polish. Do not use car wax. Do not use abrasive cleaners.
 - Do not drive the vehicle in loose dirt, sand or fine gravel which could damage moving parts, motors or the electric system.
 - When not using, all the electrical source should be turn off. Turn off the power switch and disconnect the battery connection.

In order to show how to operate the car and the instruction of product we use picture to guide you. Maybe what you bought is different from the picture, please see the real one.

In order to improve our quality, we will change the appearance and instruction without notification, please understand.

Please read the operating instructions carefully before using. Assembly it correctly, or it will hurt your children. Please keep guide book properly.



Part Name _____

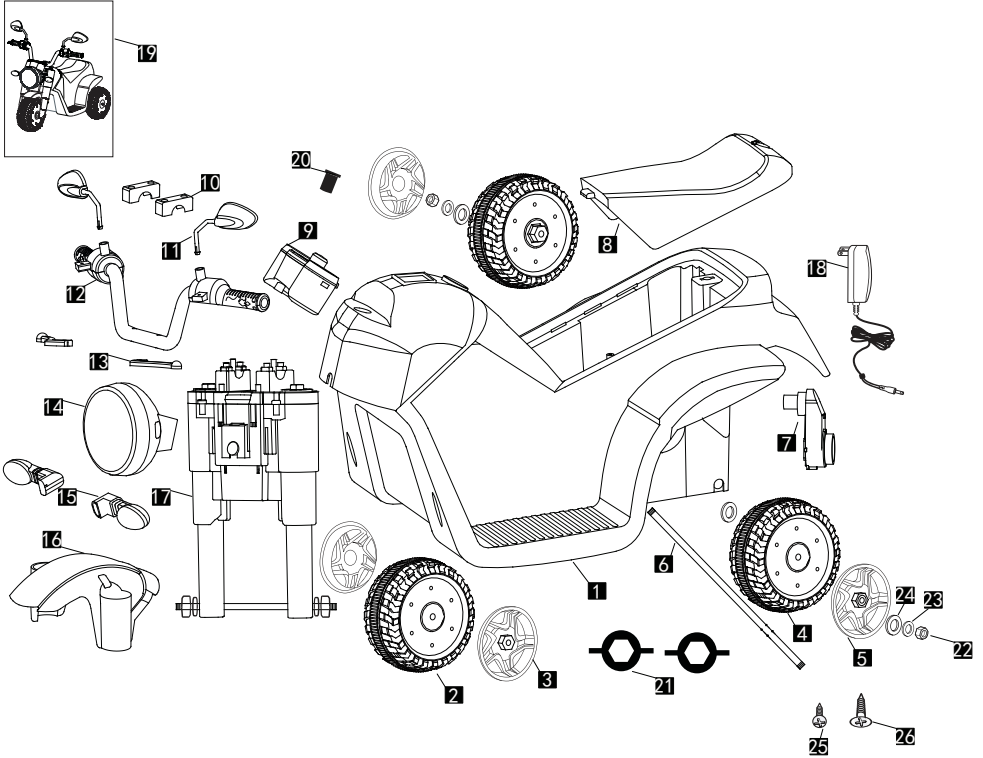

No.	part name	qty	No.	part name	qty	No.	part name	qty
1	car body	1	10	headstock	2	19	guide book	1
2	front wheel	1	11	rearview mirror	2	20	bush	1
3	front wheel cover	2	12	handlebar	1	21	M8 wrench	2
4	rear wheel	2	13	brake	2	22	M8 nut	2
5	rear wheel cover	2	14	front light	1	23	small washer	2
6	rear axle	1	15	turning light	2	24	big washer	4
7	motor	1	16	fender	1	25	4x12 screw	12+1
8	seat	1	17	front fork	1	26	4x16 screw	4
9	platform	1	18	charger	1			

How to assemble

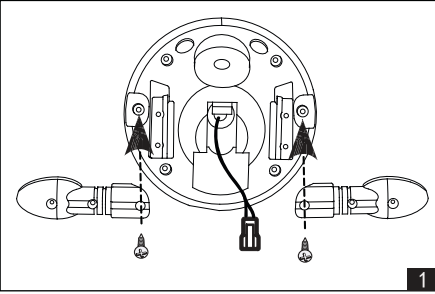

1. Assembling front light according to arrowhead, using 2pcs 4x12 screw to tighten.

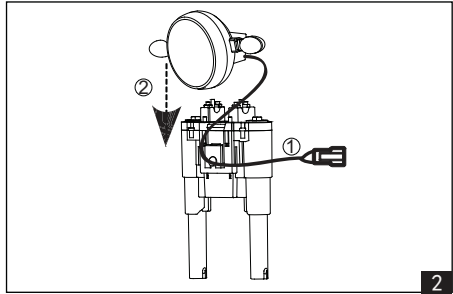

2. Passing light line through front fork(1), putting front light into front fork(2).

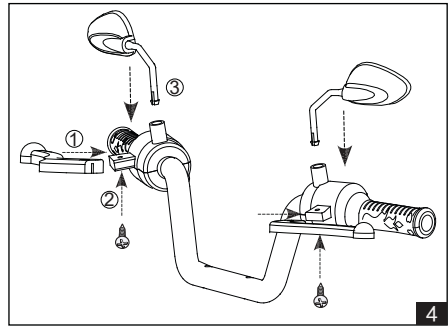
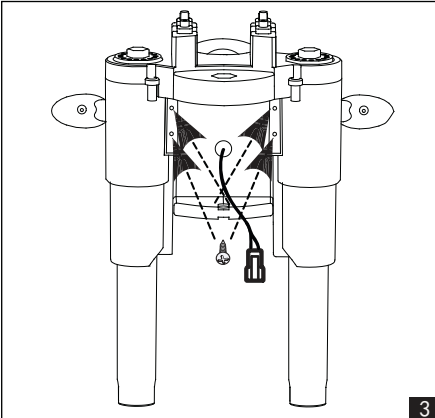

3. using 4pcs 4x12 screw to tighten.

4. Assembling brake according to arrowhead(1), using 2pcs 4x12 screw to tighten(2), assembling rearview mirror according to arrowhead(3).

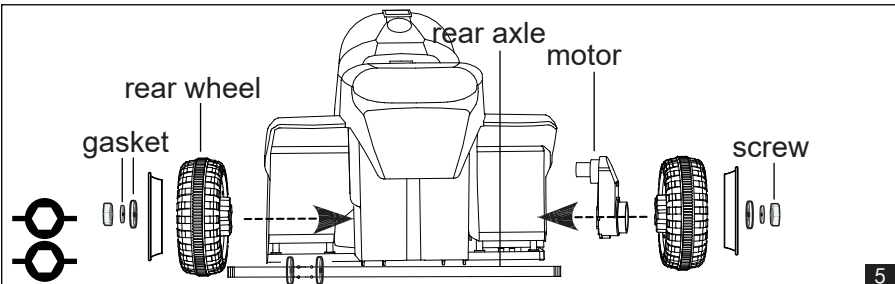

5. Assembling order to rear axle for left side is rear wheel, rear wheel cover, gasket, screw, for right side is motor, rear wheel, rear wheel cover, gasket, screw.

How to assemble and use

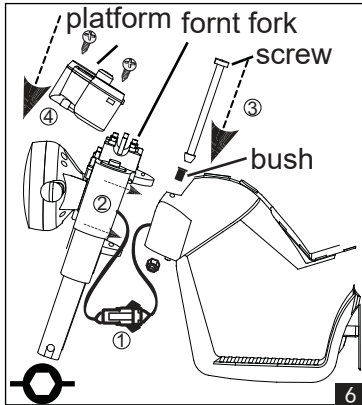

6. Inserting light line(1).
Assembling front fork(2).
Assembling bush, screw(3).
Assembling platform, using 2pcs 4x12 screw to tighten(4).

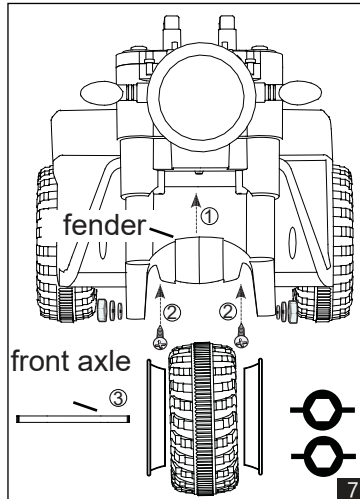

7. Assembling fender(1). Using 2pcs 4x12 screw to tighten(2).
Assembling front wheel cover first, putting front wheel into fender,
inserting front axle through front wheel(3), then one gasket each
side, using screw to tighten.

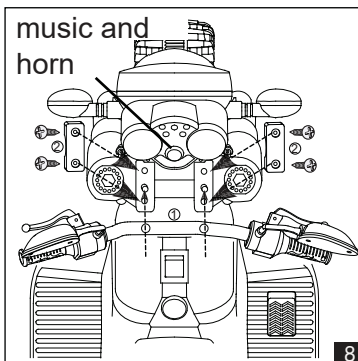

8. Inserting headstock on
the front fork(1), using 4pcs
4x16 screw to tighten.

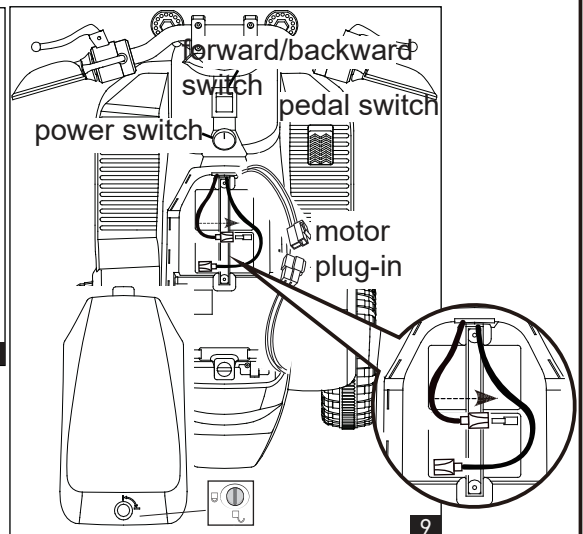

How to use and maintain _____

9. Connecting red line to battery and motor line to motor, then assembling seat. Turning on the power, pressing forward/backward switch to forward, stepping pedal switch, tricycle moves forward, turns to backward, it moves back. Car stops when you leave pedal switch.

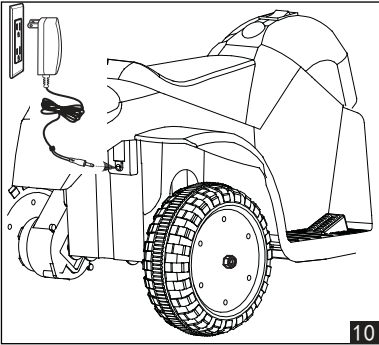

10. Battery charge: please charge tricycle when battery is low. Charging hole is on the left side of the right wheel. Connecting charging hole, then charge(10).
(Notice: cannot play when charging, charging only under adult supervision)

problem	cause	solution
car cannot move	<ol style="list-style-type: none"> 1. voltage to low 2. fuse fired 3. switch assembled uncorrect 4. battery line loose 5. battery broken 6. battery damage 7. motor broken 	<ol style="list-style-type: none"> 1. recharge 2. replace new fuse 3. reassemble according to guide book 4. reconnect 5. replace new battery 6. factory repair 7. factory repair
cannot charge	<ol style="list-style-type: none"> 1. battery line loose 2. charger no electricity 3. charger broken 	<ol style="list-style-type: none"> 1. reconnect 2. plug-in 3. replace new charger
short time for playing	<ol style="list-style-type: none"> 1. battery not full 2. battery old 	<ol style="list-style-type: none"> 1. recharge 2. replace new battery
small noise and heat when charging	chemical reaction	normal

How to maintain, warning and charging notification _____

speed slow	1. battery old 2. no power 3. overload 4. rough road	1. replace new battery 2. recharge 3. normal weight 20kg 4. smooth road
loud motor noise	gear broken	factory repair
car shaking	1. motor line loose 2. motor has dead point	1. reconnect 2. factory repair
car not move	battery line loose	reconnect
car stops	spare parts broken	factory repair

If you have any questions, please contact our customer care center.

Our contact details are below:



0044-800-240-4004



enquiries@mhstar.co.uk

IMPORTER ADDRESS:

MH STAR UK LTD

Unit 27, Perivale Park,

Horsenden lane South

Perivale, UB6 7RH

MADE IN CHINA

