

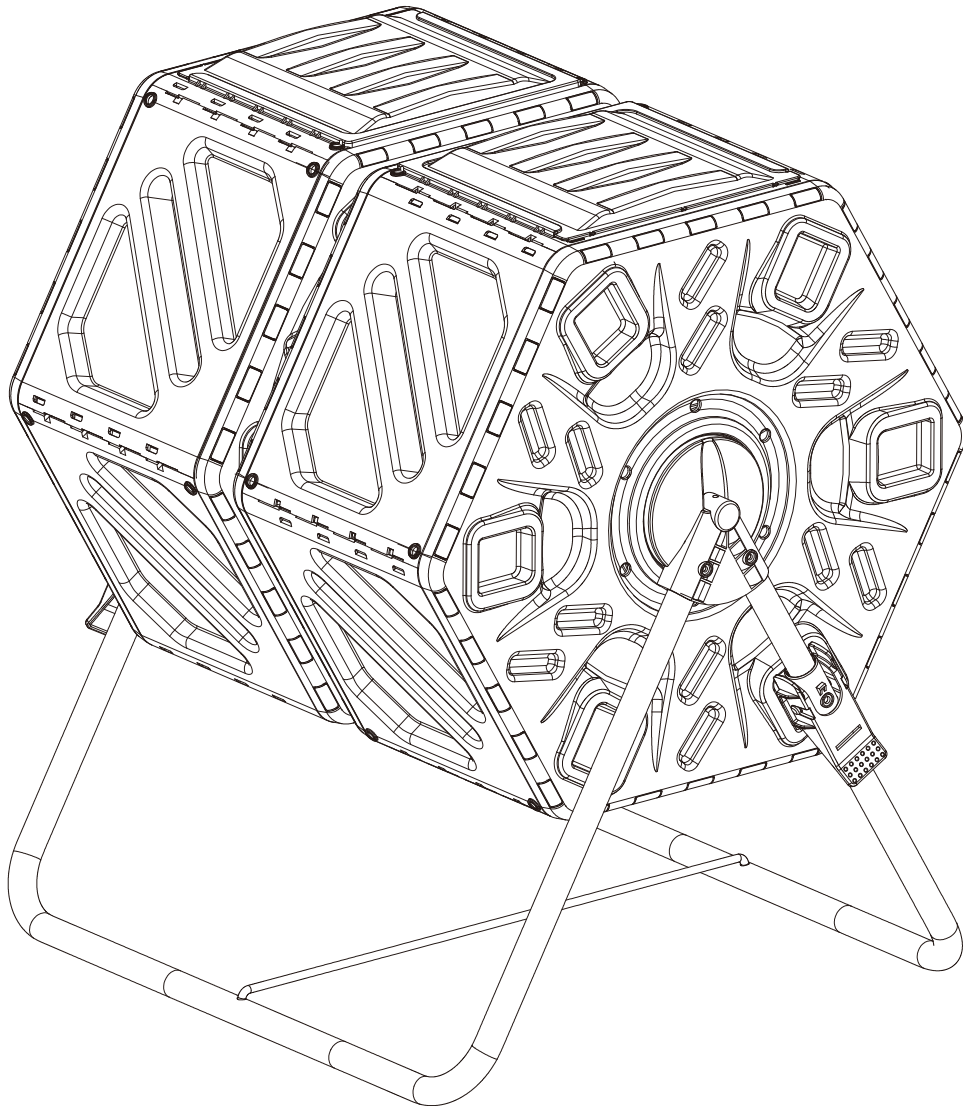

IN221100826V01_GL

845-916V00_845-916V01



EN_IMPORTANT, RETAIN FOR FUTURE REFERENCE: READ CAREFULLY.

FR_IMPORTANT: A LIRE ATTENTIVEMENT ET À CONSERVER POUR CONSULTATION ULTÉRIEURE.

ES_IMPORTANTE, LEA Y GUARDE PARA FUTURAS REFERENCIAS.

PT_IMPORTANTE, RETER PARA REFERÊNCIA FUTURA: LEIA ATENTAMENTE.

DE_WICHTIG! SORGFÄLTIG LESEN UND FÜR SPÄTER NACHSCHLAGEN AUFBEWAHREN.

IT_IMPORTANTE! CONSERVARE IL PRESENTE MANUALE PER FUTURO RIFERIMENTO E LEGGERLO ATTENTAMENTE.

EN

Dear customer,

Thank you for purchasing this product. So that your appliance serves you well, please read all the instructions in this user's manual. If you have any questions, please contact our customer care center, Our contact details are below:

FR

Cher client,

Nous vous remercions d'avoir acheté ce produit. Afin que vous puissiez profiter pleinement de votre appareil, veuillez lire toutes les instructions de ce manuel d'utilisation. Si vous avez la moindre question, veuillez contacter notre centre d'assistance à la clientèle, Nos coordonnées sont les suivantes:

DE

Sehr geehrter Kunde,

Vielen Dank, dass Sie dieses Produkt erworben haben. Damit Ihr Gerät Ihnen gute Dienste leistet, lesen Sie bitte alle Hinweise in diesem Benutzerhandbuch. Wenn Sie Fragen haben, wenden Sie sich bitte an unser Kundendienstzentrum, Unsere Kontaktdaten stehen unten:

ES

Queridos clientes,

Gracias por comprar este producto. Para que su electrodoméstico le sirva mejor, lea todas las instrucciones de este manual del usuario. Si tiene alguna pregunta, comuníquese con nuestro Centro de Atención al Cliente, Nuestros datos de contacto son los siguientes:

PT

Caros clientes,

Obrigado por adquirir este produto. Para que o seu aparelho o sirva melhor, leia todas as instruções deste manual do utilizador. Se tiver alguma dúvida, por favor contacte o nosso Centro de Atendimento ao Cliente, Os nossos dados de contacto são os seguintes:

IT

Caro Cliente,

Grazie per aver acquistato questo prodotto. Per servirti meglio con questo apparecchio ti prego di leggere tutte le istruzioni in presente manuale utente. In caso di dubbio, si prega di contattare il nostro centro assistenza clienti, I nostri dettagli di contatto sono di seguito:

Country	 Phone	 Email
US	001-877-644-9366	customerservice@aosom.com
CA	416-792-6088	customerservice@aosom.ca
UK	0044-800-240-4004	enquiries@mhstar.co.uk
DE	0049-0(40)-88307530	service@aosom.de
FR	0033-1-84166106	aosom@mhfrance.fr
ES&PT	0034-931294512	atencioncliente@aosom.es
IT	0039-0249471447	clienti@aosom.it

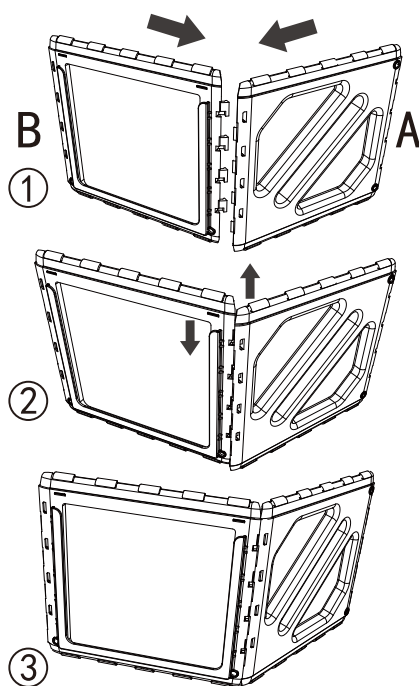
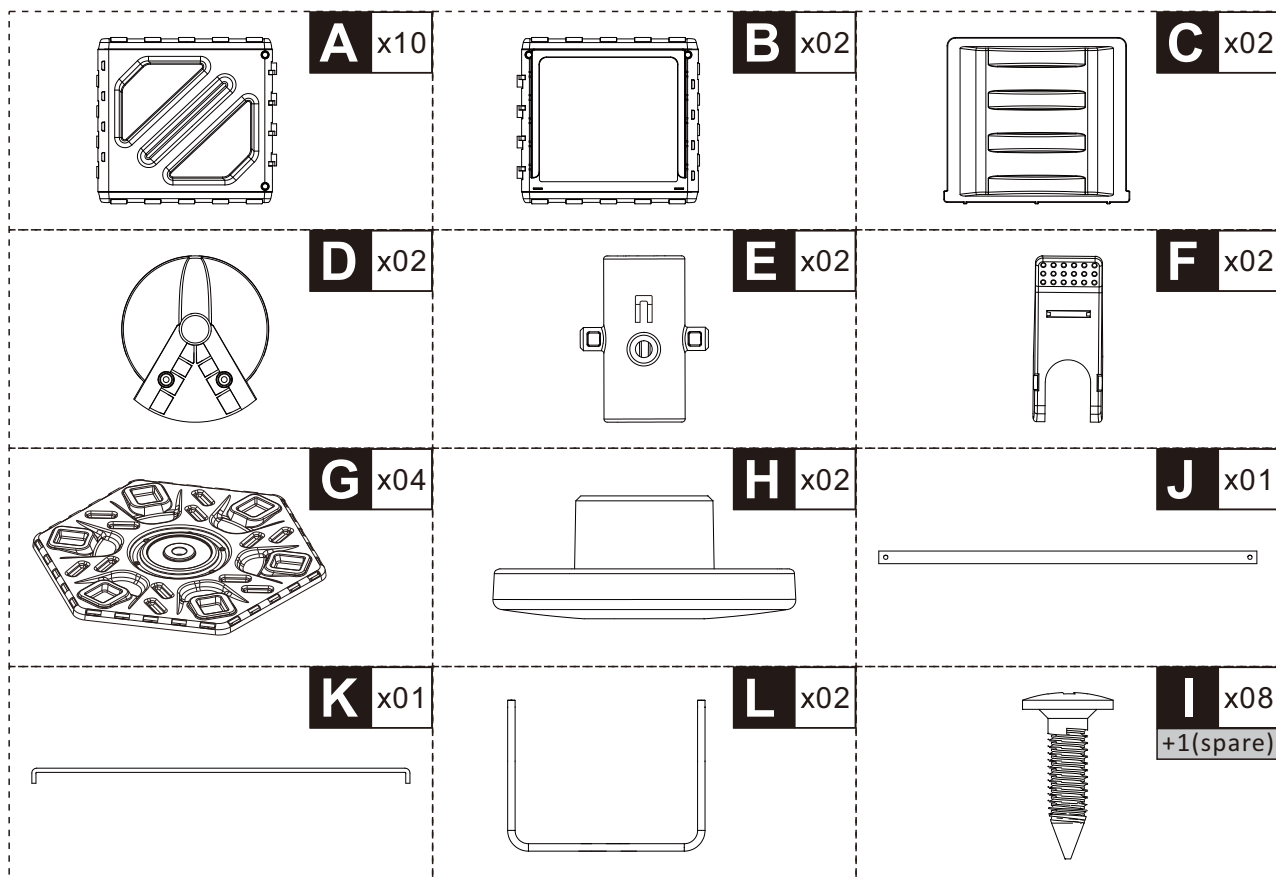

EN Match A and B and slide into the right position
FR Faites correspondre A et B et glissez-les dans la bonne position.
ES Haz coincidir A y B y deslízate en la posición correcta
PT Faça corresponder A e B e deslize para a posição correcta
DE A und B zusammenbringen und in die richtige Position schieben
IT Abbinare A e B e farli scorrere nella posizione giusta.

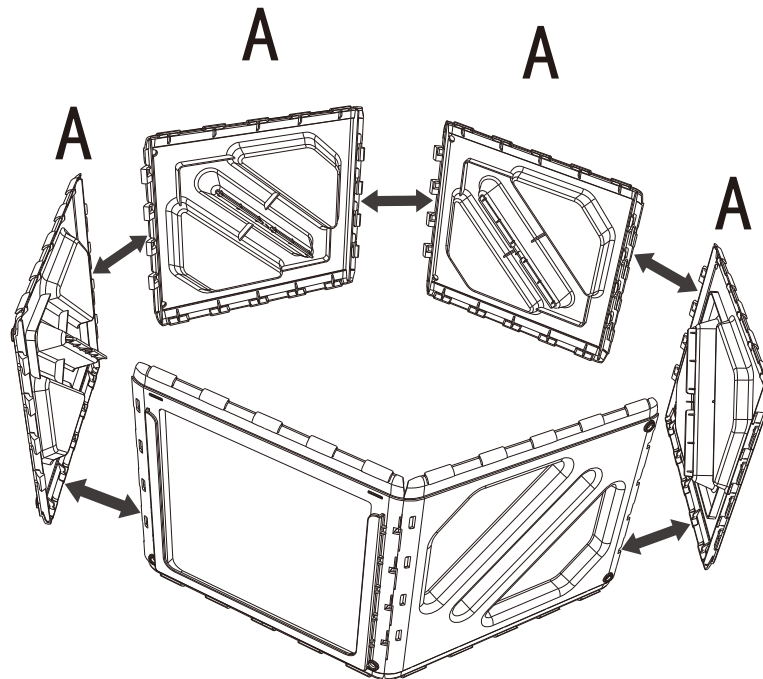

EN_repeat with the rest 4 of A panels
FR_répétez avec les 4 autres panneaux A
ES_repetir con el resto de los 4 paneles A
PT_repetir com os restantes 4 painéis A
DE_Wiederholen Sie den Vorgang mit den restlichen 4 Platten von A
IT_ripetere con gli altri 4 pannelli di A

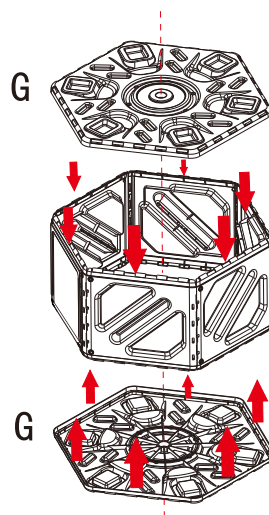

EN_Finish the first chamber after click on the two side panels and assemble the second chamber by the same way
FR_Terminez la première chambre après avoir cliqué sur les deux panneaux latéraux et assemblez la deuxième chambre de la même manière.
ES_Termina la primera cámara después de hacer clic en los dos paneles laterales y monta la segunda cámara de la misma manera
PT_Acabar a primeira câmara depois de clicar nos dois painéis laterais e montar a segunda câmara da mesma maneira
DE_Fertigstellung der ersten Kammer nach Anklicken der beiden Seitenteile und Montage der zweiten Kammer auf die gleiche Weise
IT_Terminate la prima camera dopo aver cliccato sui due pannelli laterali e assemblate la seconda camera nello stesso modo.

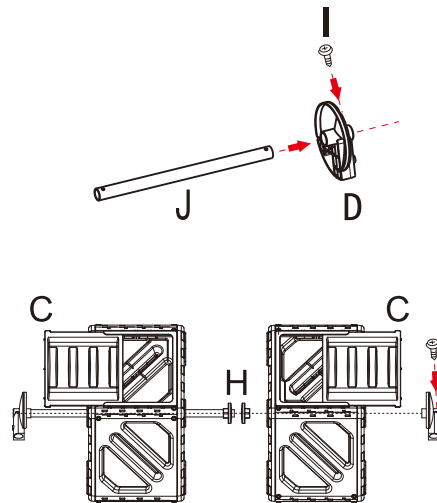

EN Make sure the parts C towards out side when you put two chambers together with part J

FR Assurez-vous que les pièces C sont orientées vers l'extérieur lorsque vous assemblez deux chambres avec la pièce J.

ES Asegúrese de que las partes C hacia el lado exterior cuando usted pone dos cámaras junto con la parte J

PT Assegure-se de que as partes C para o exterior quando colocar duas câmaras juntas com a parte J

DE Achten Sie darauf, dass die Teile C nach außen zeigen, wenn Sie zwei Kammern mit Teil J zusammensetzen.

IT Assicurarsi che le parti C siano rivolte verso il lato esterno quando si uniscono le due camere con la parte J.

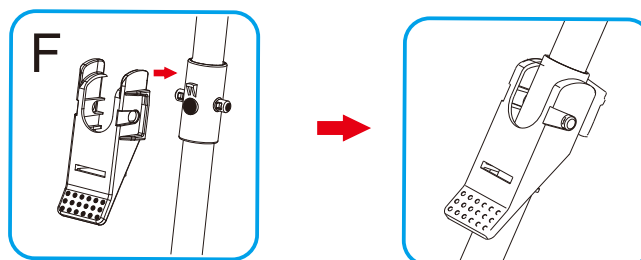
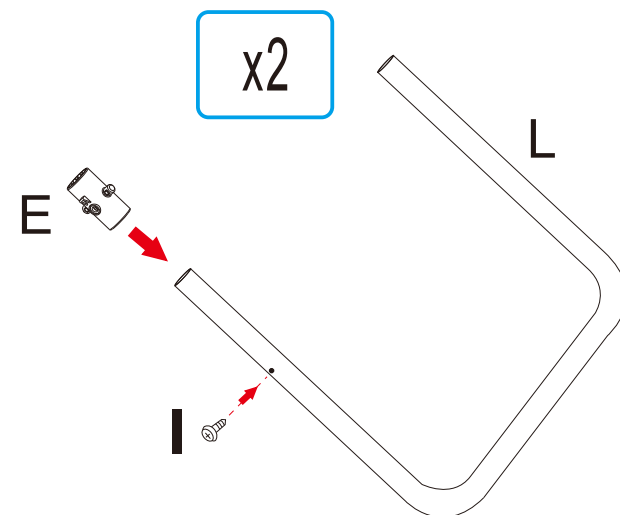

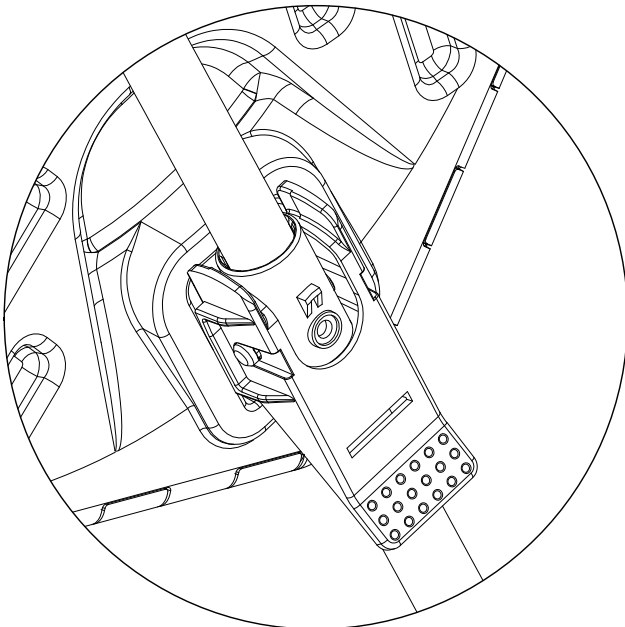
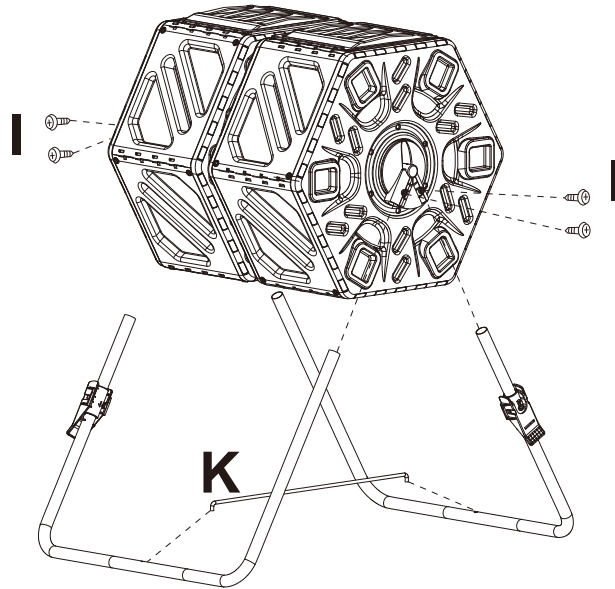
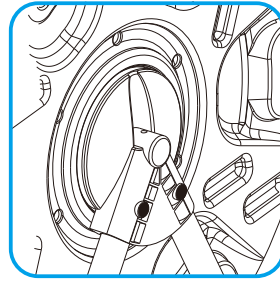

ON

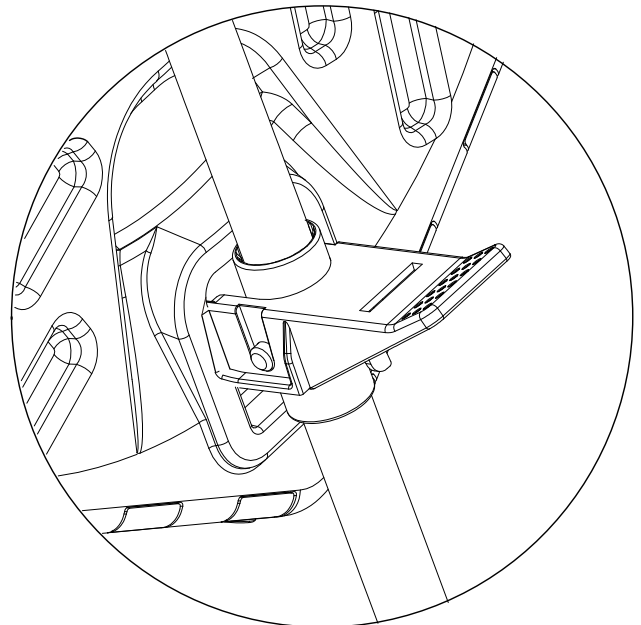

OFF

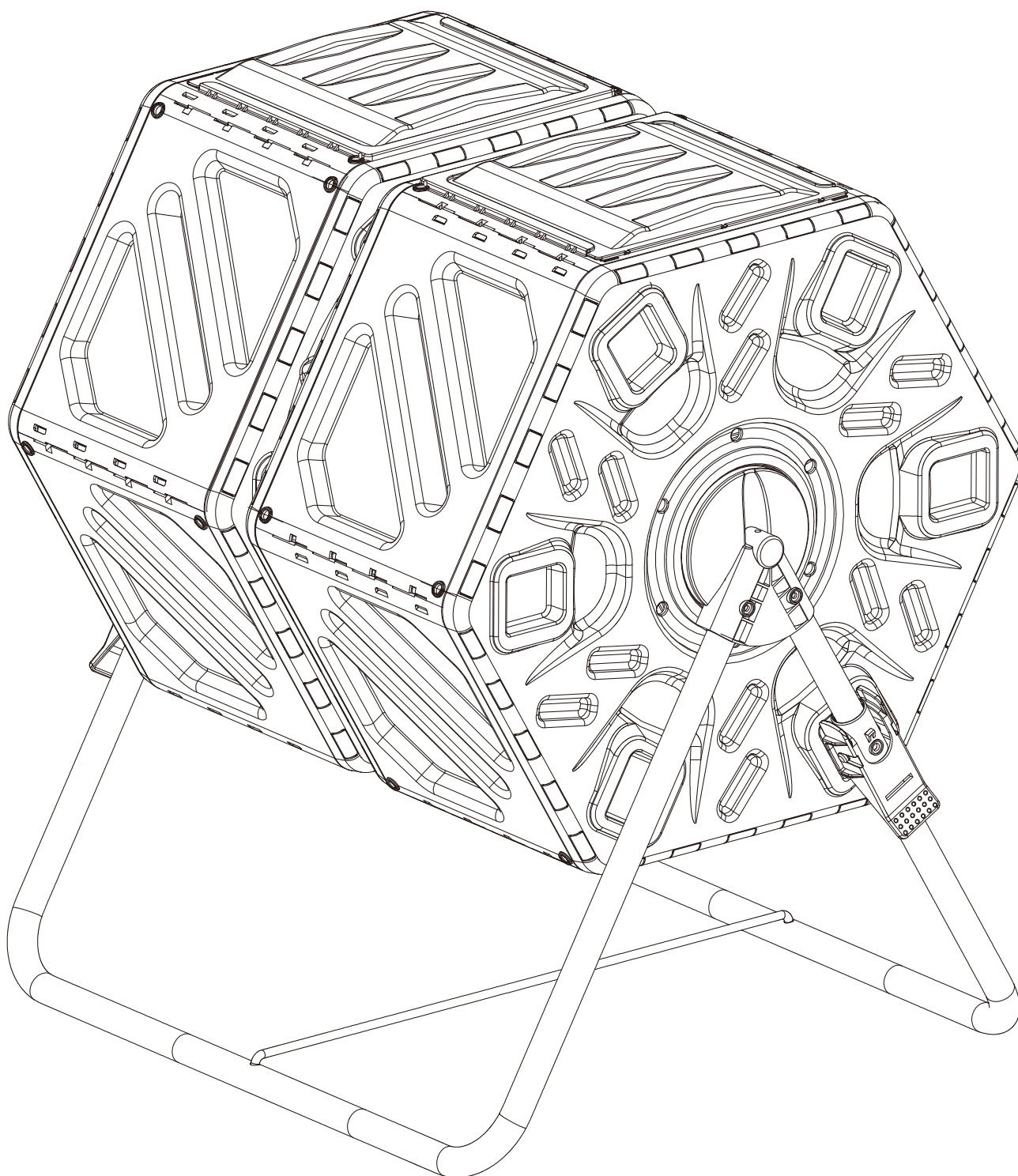

US

Imported by Aosom LLC
27150 SW Kinsman Rd Wilsonville, OR 97070 USA
MADE IN CHINA

CA

Imported by Aosom Canada Inc.
1251 Tapscott Road, Unit 101, Scarborough, Ontario Canada M1X 1S9
MADE IN CHINA

Importé par Aosom Canada Inc.
1251 Rue Tapscott, Unité 101, Scarborough, Ontario Canada M1X 1S9
FABRIQUÉ EN CHINE

UK

IMPORTER ADDRESS:
MH STAR UK LTD
Unit 27, Perivale Park,
Horsenden lane South
Perivale, UB6 7RH
MADE IN CHINA

FR

ADRESSE D'IMPORTATION:
MH FRANCE
2 Rue Maurice Hartmann
92130 Issy Les Moulineaux
France
FABRIQUÉ EN CHINE



<https://quefairedemesdechets.fr>

ES

IMPORTADOR:
SPANISH AOSOM, S.L.
C/ROC GROS,Nº15.08550, ELS HOSTALET DE BALENYÀ, SPAIN.
B66295775
WWW.AOSOM.ES
ATENCIONCLIENTE@AOSOM.ES
TEL: 931294512
HECHO EN CHINA

DE

ADRESSE DES IMPORTEURE:
MH Handel GmbH
Wendenstraße 309
D-20537 Hamburg
Germany
IN CHINA HERGESTELLT

IT

IMPORTATO DA:
AOSOM Italy srl
Centro Direzionale Milanofiori
Strada 1 Palazzo F1
20057 Assago (MI)
P.I.: 08567220960
FATTO IN CINA