

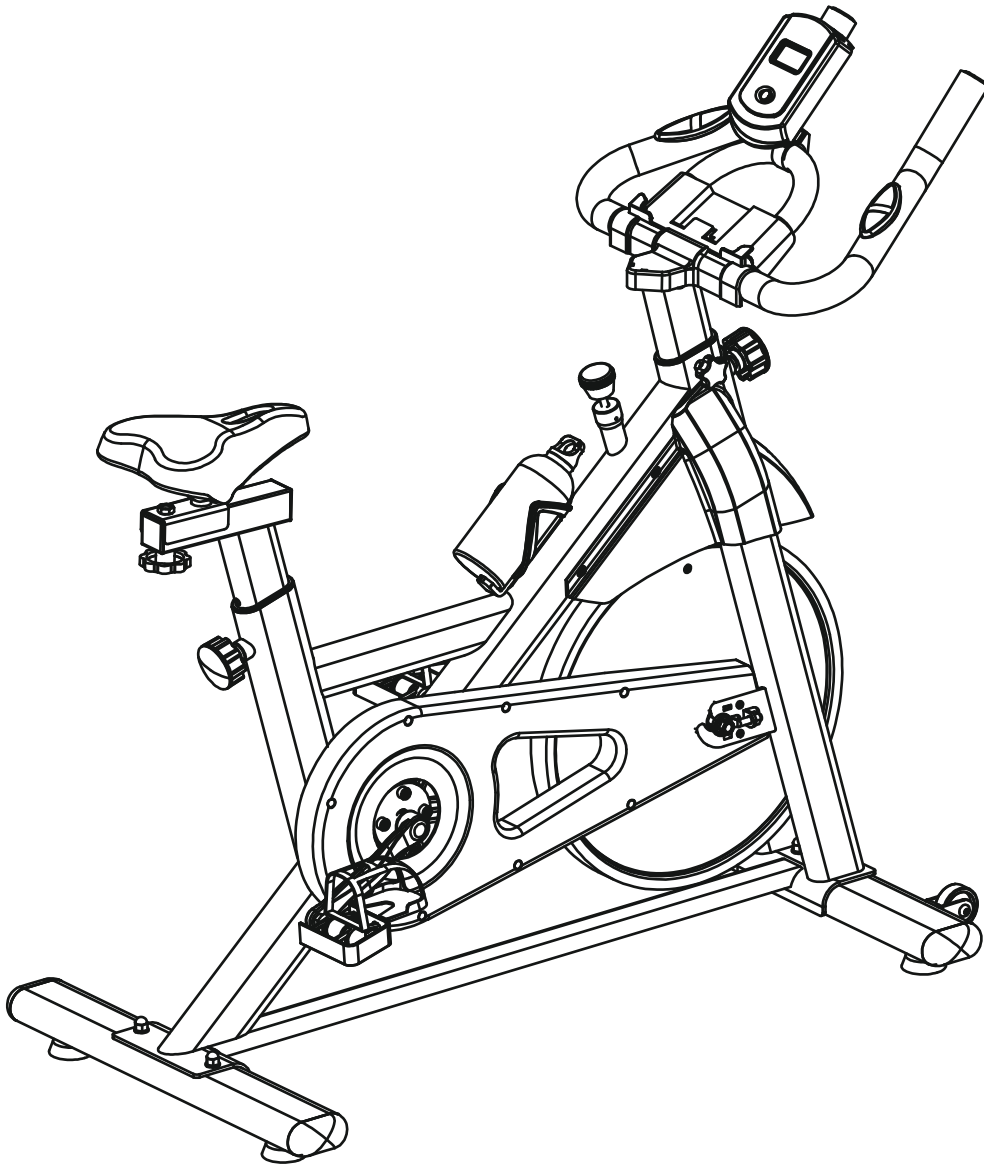

IN230100077V02\_UK

**A90-213V01**



**CAUTION:**

MAX USER WEIGHT: 150KG

IMPORTANT, RETAIN FOR FUTURE REFERENCE: READ CAREFULLY

**ASSEMBLY & INSTRUCTION MANUAL**

# SAFETY INFORMATION

## WARNING

TO REDUCE THE RISK OF SERIOUS INJURY, READ THE FOLLOWING SAFETY INSTRUCTIONS BEFORE USING THE EQUIPMENT.

### IMPORTANT: THIS UNIT IS INTENDED FOR HOME USE ONLY

1. It is important to read this entire manual before assembling and using the equipment. Safe and efficient use can only be achieved if the equipment is assembled, maintained and used properly. It is your responsibility to ensure that all users of the equipment are informed of all warnings and precautions.
2. Before starting any exercise program you should consult your doctor to determine if you have any physical or health conditions that could create a risk to your health and safety, or prevent you from using the equipment properly. Your doctor's advice is essential if you are taking medication that affects your heart rate, blood pressure or cholesterol level.
3. Be aware of your body's signals. Incorrect or excessive exercise can damage your health. Stop exercising if you experience any of the following symptoms: Pain, tightness in your chest, irregular heartbeat, extreme shortness of breath, feeling light headed, dizzy or nauseous. If you do experience any of these conditions you should consult your doctor before continuing with your exercise program.
4. Keep children and pets away from the equipment. The equipment is designed for adult use only.
5. Use the equipment on a solid, flat level surface with a protective cover for your floor or carpet. For safety, the equipment should have at least 0.6 metre of free space all around it.
6. Before using the equipment, check the nuts and bolts are securely tightened.
7. The safety level of the equipment can only be maintained if it is regularly examined for damage and/or wear and tear.
8. Always use the equipment as indicated. If you find any defective components whilst assembling or checking the equipment, or if you hear any unusual noise coming from the equipment during use, stop. Do not use the equipment until the problem has been rectified.
9. Wear suitable clothing whilst using the equipment. Avoid wearing loose clothing which may get caught in the equipment or that may restrict or prevent movement.
10. The equipment has been tested and certified to EN ISO 20957-1; EN ISO 20957-5 under class H.C. Suitable for domestic, home use only. Maximum weight of user 150kg.
11. This equipment is not suitable for high precision applications.
12. Care must be taken when lifting or moving the equipment so as not to injure your back. Always use proper lifting techniques and/or use assistance.

# EXPLODED DRAWING

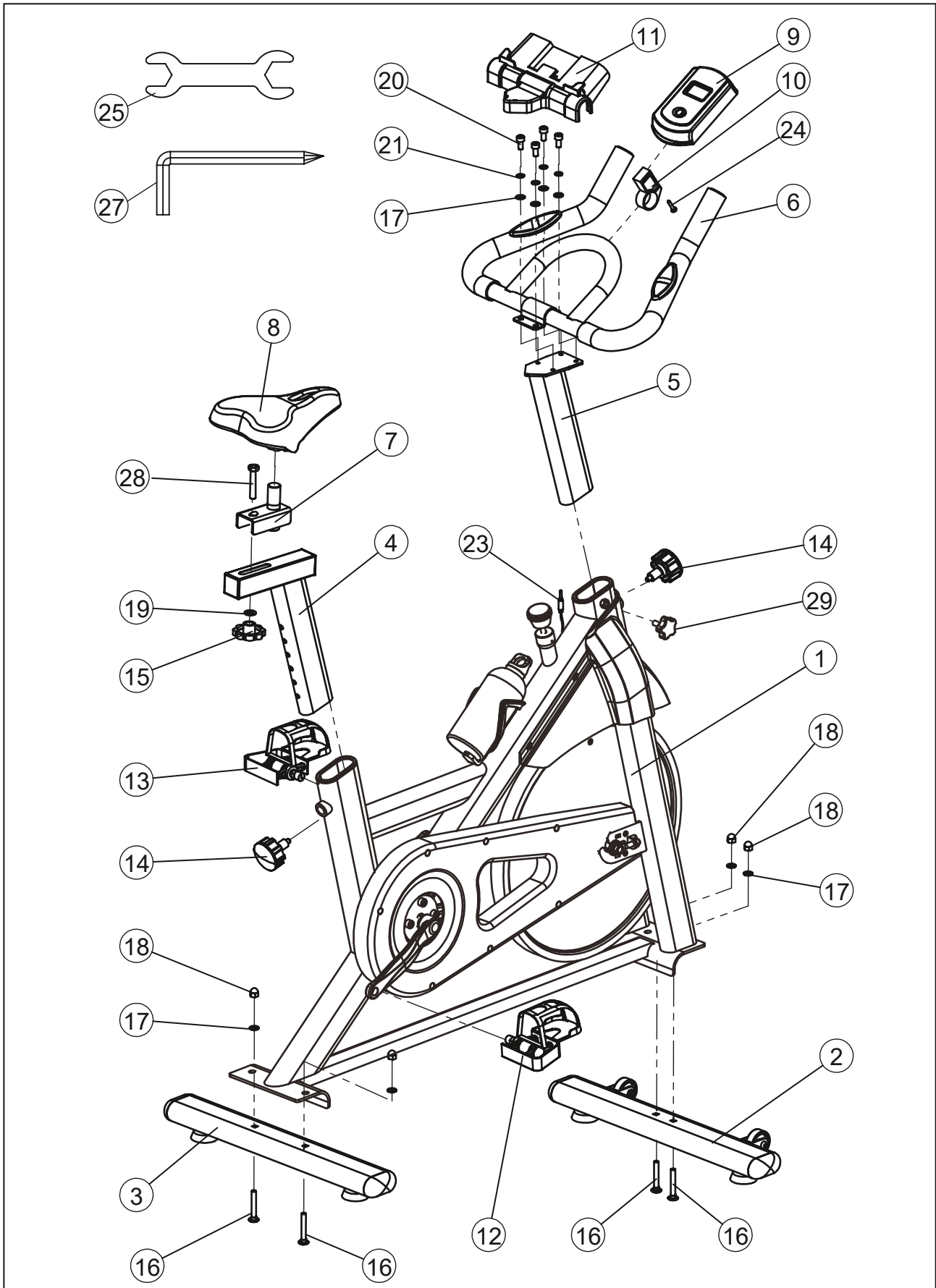

# PARTS LIST

NO.	NAME	SIZE	QTY.	NO.	NAME	SIZE	QTY.
1	Main Body	Assembly	1	15	Adjusting nut	M10	1
2	Front Stabilize	Assembly	1	16	Carriage Bolts	M8X50	4
3	Rear Stabilizer	Assembly	1	17	Flat washer	Φ8.5	8
4	Saddle Post	Assembly	1	18	Cover nut	M8	4
5	Handle Post	Assembly	1	19	Flat washer	Φ10.5	1
6	Handle Frame	Assembly	1	20	Button head bolt	M8X16	4
7	Saddle Adjustment Frame	Assembly	1	21	Spring washer	Φ8.5	4
8	Saddle	Spring loaded	1				
9	Monitor	Square	1	23	Signal Wire		1
10	Monitor Holder	fit for Φ25tube	1	24	Self tapping screw	ST5X25	1
11	Mobile phone holder	fit for Φ25tube	1	25	Open wrench	13-15	1
12	Right pedal	R	1	27	Inner hexagon spanner	6mm	1
13	Left pedal	L	1	28	six angle bolts	M10X55	1
14	Adjusting knob	M16	2	29	Adjusting nut	M8	1

# ASSEMBLY INSTRUCTIONS

## STEP 1

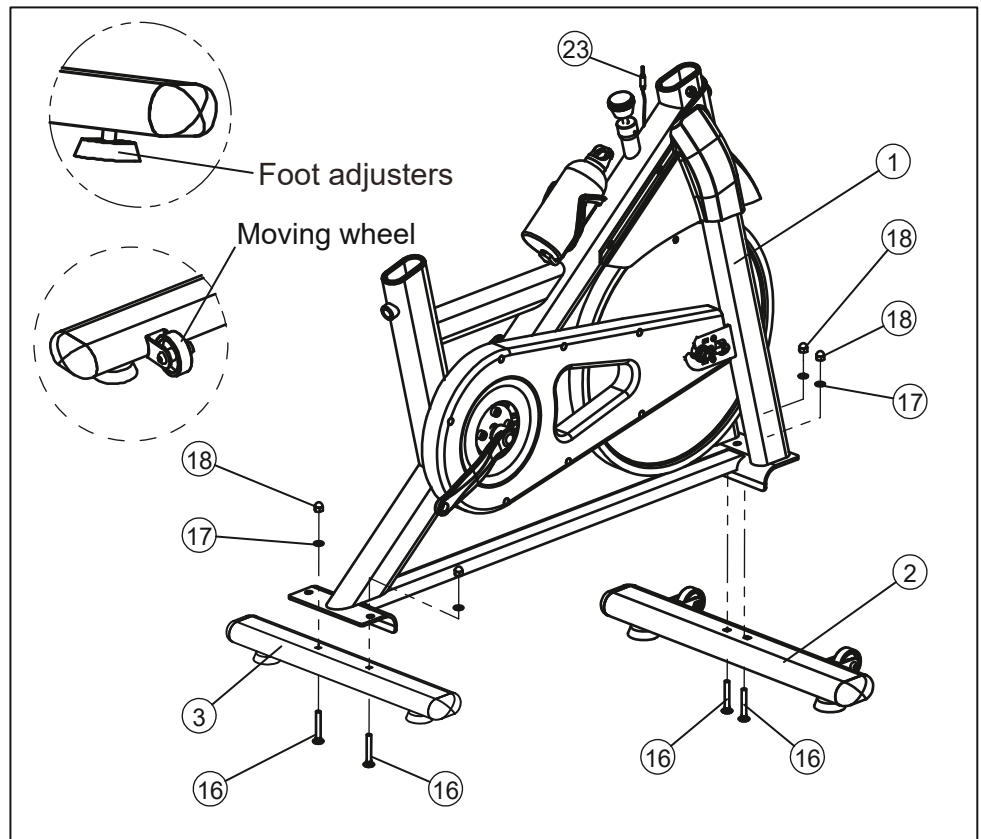
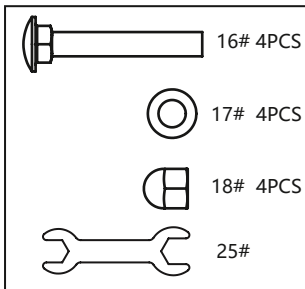

The Front Stabilize (2) is fixed on the Main Body (1) with Carriage Bolts (16), Flat washers (17) and cover nuts (18), and fixed with open wrench (25). Note: the move wheels of the Front Stabilize(2) are forward,as shown.

Similarly, the Rear Stabilizer (3) is fixed on the Main Body (1) with carriage Bolts (16), flat washers (17) and cover nuts (18), and fixed with open wrench (25).

Attention: The foot adjusters on the rear stabilizer (3) can adjust the machine to the ground smoothly.The moving wheels on both sides of The Front Stabilize (2) can move the machine in a short distance.

## STEP 2

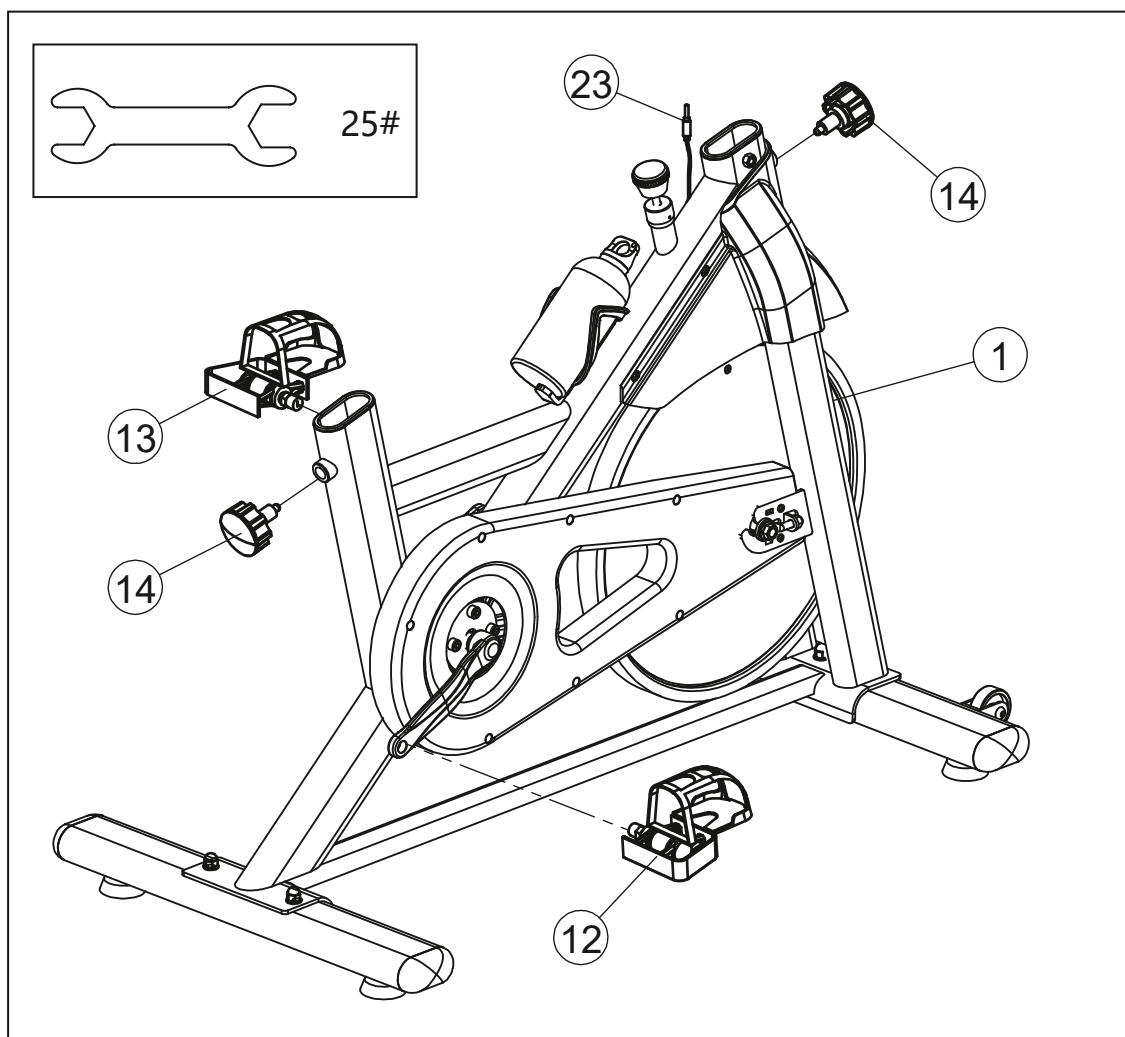

Install the right pedal (12) with R mark on The Main Body (1) and fix it with an open wrench (25). Note: tighten it clockwise.

Similarly, Install the left pedal (13) with L mark on the Main Body (1) and fixed with an open wrench (25). Note: tighten counterclockwise.

The adjusting knobs (14) is installed in front and back of the Main Body(1) respectively. Note that no tightening is needed at this time.

### STEP 3

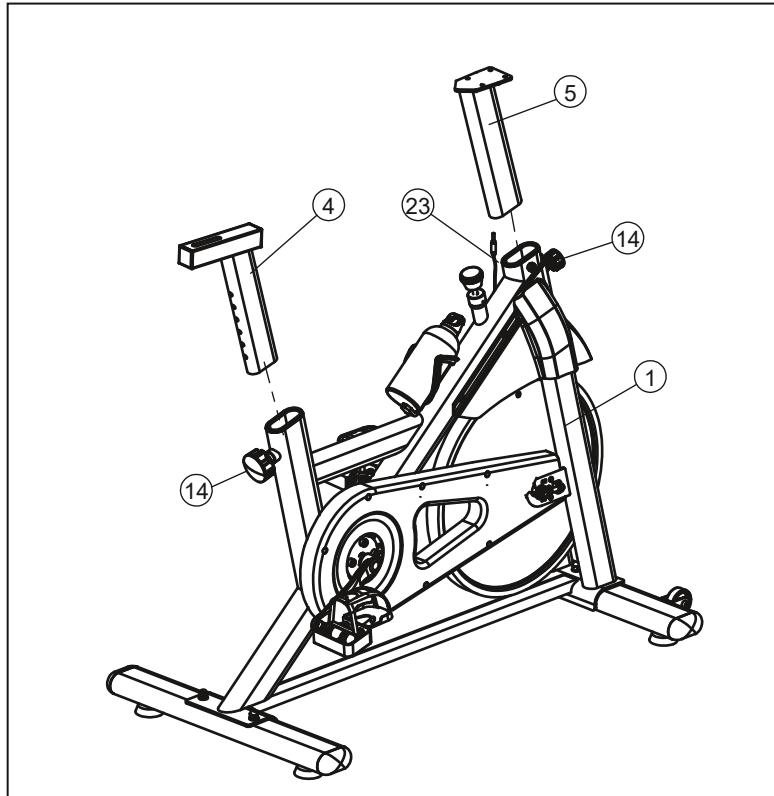

The Saddle Post (4) is inserted into the Main Body (1), and the Adjusting knob (14) is pulled out so that the Adjusting knob (14) is automatically inserted into the corresponding hole of the Saddle Post (4).

Similarly, the Handle Post (5) is inserted into the Main Body (1), and the Adjusting knob (14) is pulled out so that the Adjusting knob (14) is automatically inserted into the corresponding hole of the Handle Post (5).

Note: Pull out the Adjusting knob (14) can adjust the height of the Saddle Post (4) or the Handle Post(5). After adjusting, it is necessary to tighten the Adjusting knobs (14).

### STEP 4

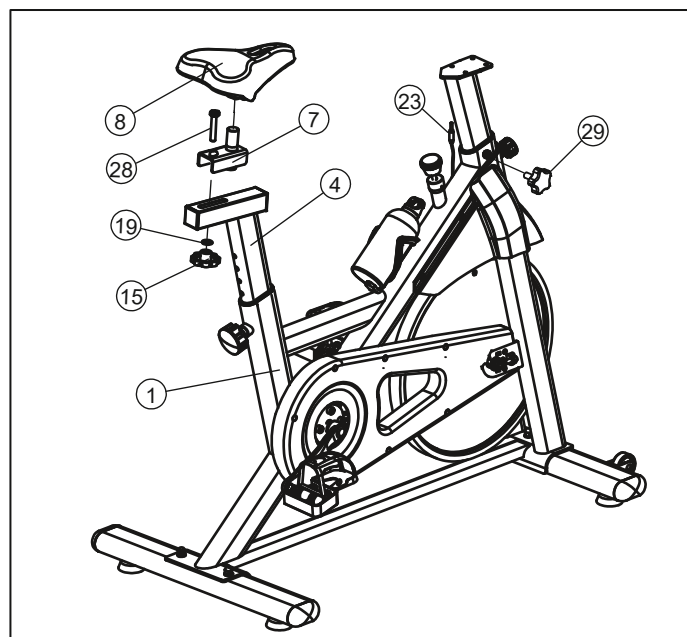
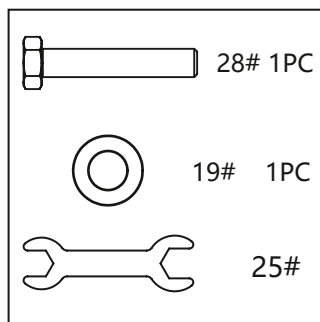

The Saddle Adjustment Frame (7) is installed in the Saddle Post (4) and fixed with the Flat washer (19), an six angle bolts (28) and a adjusting nut (15). Then the Saddle (8) is arranged on the Saddle Adjustment Frame (7), and is fixed and tightened with the open wrench (25). Install adjusting nut(29) on main body(1).

Note: Loosening the adjusting nut (15) can adjust the Saddle Adjustment Frame (7) position before and after adjusting to the corresponding position, the adjusting nut (15) needs to be tightened . The adjusting nut(29) can reinforce the handlevpost(5).

## STEP 5

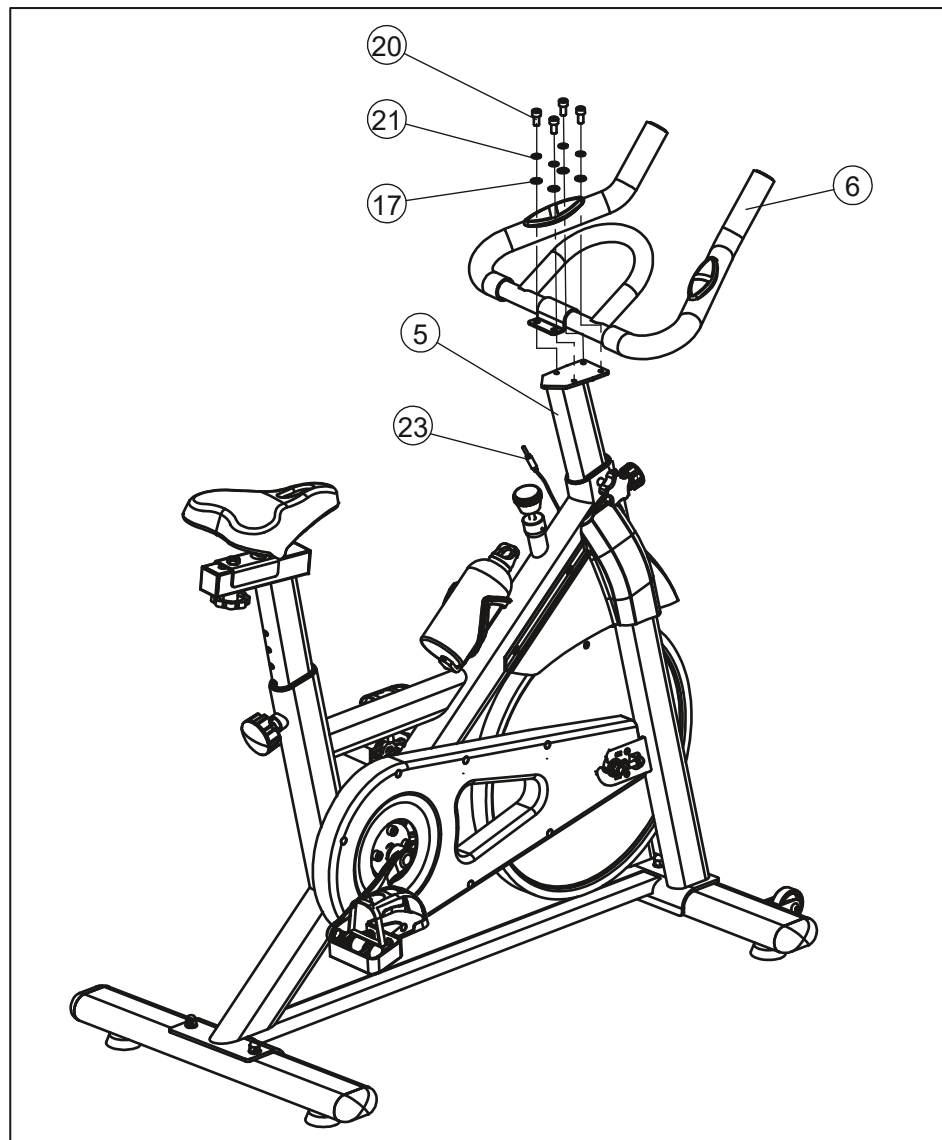
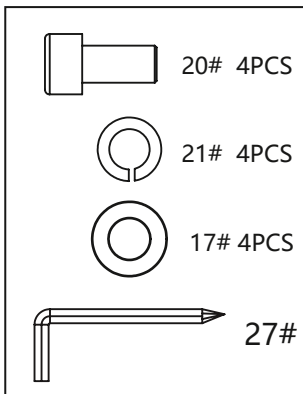

The Handle Frame (6) is fixed on the Handle Post (5) with Flat washers(17), the Spring washers (21) and the Button head bolts (20), and tightened with an inner hexagonal wrench (27).

## STEP 6

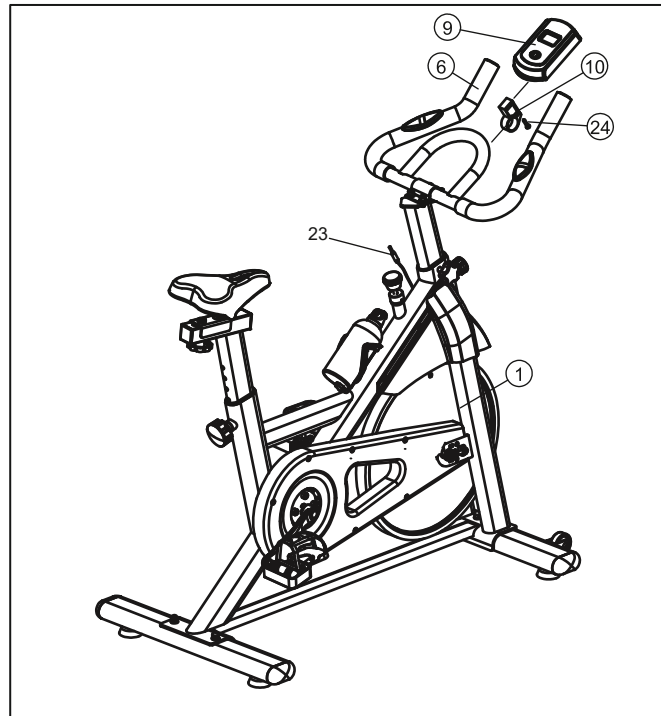
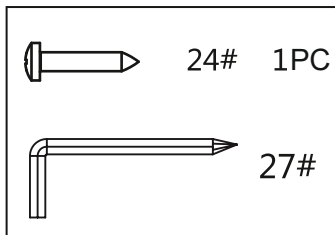

The Monitor Holder (10) is pulled and fixed on the Handle Frame (6) with the Self tapping screw (24) and tightened with the inner hexagonal wrench (27).

The Monitor (9) is mounted on the Monitor Holder (10).  
Insert the Signal Wire (23) into the "sensor" hole on the back of the Monitor(9).

## STEP 7

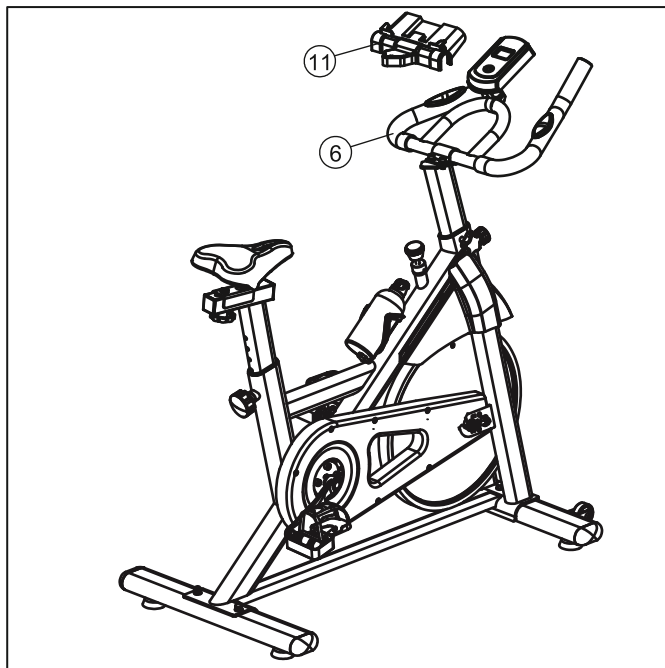

Install the Mobile phone holder (11) on the Handle Frame (6).

**CAUTION:** before using, please reconfirm that each part is tight and firm, and the machine is stable with the ground.



# COMPUTER FUNCTION



## A, BATTERY INSTALLATION

Load two 1.5V AA battery in the battery box on the back (after each battery replacement, all values will be "0")

## B, FUNCTIONAL DESCRIPTION

- 1, automatic scanning (SCAN): open the screen or press the button to enter the SCAN state, all the functions of the TIME--SPD--DIST--CAL--ODO--PUL will be automatically displayed on the main screen.
- 2, the movement time (TIME): cumulative calculation of movement time from 00:00--99:59, the user can press the button to select the time value display state.
- 3, the movement distance (DIST): cumulative calculation movement from the 0.0--999.9, the user can press the button to select the value of the distance display.
- 4, calories (CAL): shows that the cumulative consumption of calories from 0.0--9999, the user can press the button to select the value of the state of the display value. **Note: this data is only a rough description and cannot be used for medical treatment.**
- 5, the speed of movement (SPEED): show the current speed of the athlete, the value of 0.0--999.9 km / mile / hour.
- 6, Odometer (ODO): the distance between motion and time is 0-9999 km.
- 7, Pulse (PUL): instant heart rate, 40-240 times / minute, Note: this data is only a rough description and cannot be used for medical treatment.
- 8, reset: hold down the button for about 3 seconds, all the values will be returned to the "0", the function can be reset.

## C, ATTENTION

- 1, such as electronic display is not normal, the need to re install the battery to try again, the battery "+", "-" can not be installed.
- 2, battery specification: 1 AA 5 1.5V battery
- 3, When the battery is scrapped, it must be removed from the electronic watch and handled safely.

## TRAINING INSTRUCTIONS

IN ADDITION TO THE USE OF THE EQUIPMENT CAN ENHANCE PHYSICAL FITNESS AND EXERCISE MUSCLES, BUT ALSO THROUGH A REASONABLE DIET TO PLAY A ROLE IN WEIGHT LOSS.

### A, warm-up before training

This phase of warm up exercise can enhance the body's blood circulation, and the muscles to achieve good training, while reducing the risk of cramps or muscle damage during training. Before each training please do warm-up exercise in accordance with the following recommendations of the training, each stretch must be maintained for about 30 seconds, while doing this exercise not stretching intensity, prevent muscle damage, once the muscles are damaged, please stop the practice.

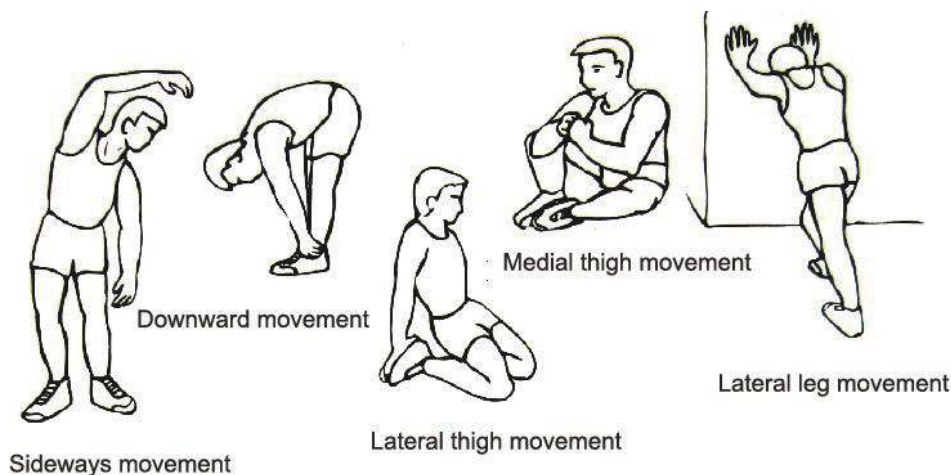

### B, training stage

This stage is the formal training phase, after a long period of practice can improve the flexibility of the leg muscles. In the training process, the key is to do the training according to the training condition, and to choose the reasonable training intensity.

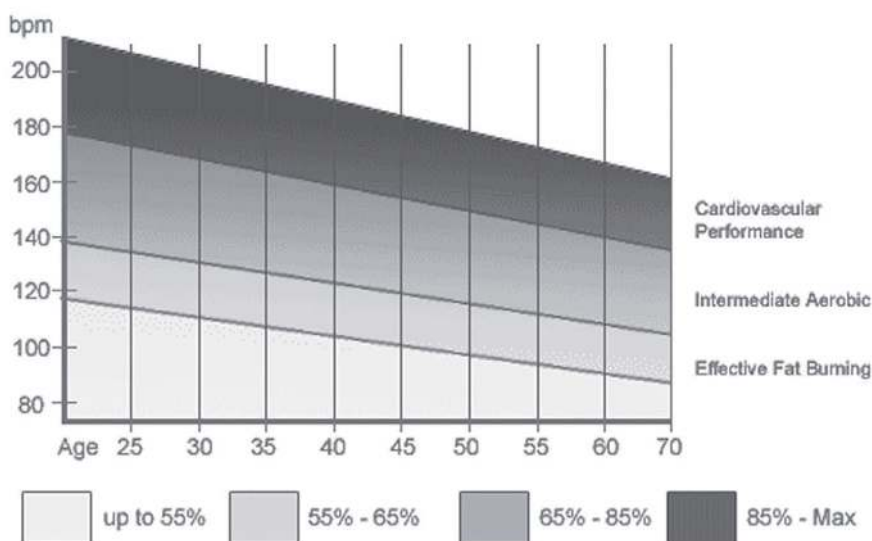

#### Note:

To keep the heart rate within the corresponding target range for at least 1 minutes of training, most people in the beginning of training lasted 15--20 minutes.

**UK**

If you have any questions, please contact our customer care center.

Our contact details are below:



0044-800-240-4004



enquiries@mhstar.co.uk

IMPORTER ADDRESS:

MH STAR UK LTD

Unit 27, Perivale Park,  
Horsenden lane South

Perivale, UB6 7RH

MADE IN CHINA

**ES**

Si tiene alguna pregunta, comuníquese con nuestro Centro de Atención al Cliente. Nuestros datos de contacto son los siguientes:



0034-931294512



atencioncliente@aosom.es

IMPORTADOR:

SPANISH AOSOM, S.L.

C/ ROC GROS, N° 15. 08550, ELS HOSTALETS DE  
BALENYÀ, SPAIN.

B66295775

WWW.AOSOM.ES

ATENCIONCLIENTE@AOSOM.ES

TEL: 931294512

HECHO EN CHINA

**FR**

Si vous avez la moindre question, veuillez contacter notre centre d'assistance à la clientèle.

Nos coordonnées sont les suivantes:



0033-1-84166106



aosom@mhfrance.fr

Importé par:

MH France

2, rue Maurice Hartmann

92130 Issy-les-Moulineaux

France

Fabriqué en Chine

**PT**

Se tiver alguma dúvida, por favor contacte o nosso Centro de Atendimento ao Cliente. Os nossos dados de contacto são os seguintes:



0034-931294512



info@aosom.pt.

IMPORTADOR:

SPANISH AOSOM, S.L

C.ROC GROS N.15, 08550. ELS HOSTALETS DE BALENYÀ

TEL: 931294512 (SEG-SEX DAS 7:30H ÀS 16:30H)

INFO@AOSOM.PT

WWW.AOSOM.PT

**DE**

Wenn Sie Fragen haben, wenden Sie sich bitte an unser Kundendienstzentrum.

Unsere Kontaktdaten stehen unten:



0049-(0)40-88307530



service@aosom.de

ADRESSE DES IMPORTEURE:

MH Handel GmbH

Wendenstraße 309

D-20537 Hamburg

Germany

IN CHINA HERGESTELLT

**IT**

In caso di dubbio, si prega di contattare il nostro centro assistenza clienti. I nostri dettagli di contatto sono di seguito:



0039-0249471447



clienti@aosom.it

IMPORTATO DA:

AOSOM Italy srl

Centro Direzionale Milanofiori

Strada 1 Palazzo F1

20057 Assago (MI)

P.I.: 08567220960

FATTO IN CINA