



Assembly video please scan the QR code .



WARNING!

- The toy must be assembled by adults.



IMPORTANT, RETAIN FOR FUTURE REFERENCE: READ CAREFULLY

ASSEMBLY INSTRUCTION

Specifications:	
Battery:	6V4.5AH*1
Motor:	6V 20W*1
Suitable ages:	18-36 months
Maximum weight:	25KG
Speed :	0-3km/h
Power way:	Charging type
Use of time:	Charg: 8-12 hours ; Use: 0.75 hours
Charger:	Input AC 120~240 V, 50~60Hz, output DC 6 V 500mA

WARNING

1.The pictures in this instruction is only for explaining the operation and structure of the product, when there's any difference with the real product, please confirm with the real product.

2.In order to improve the quality of the product,we may amend some structure or appearance of the product without notification.Thank you for your understanding.

FOR THE SAFETY OF YOUR CHILD, PLEASE READ ALL WARNINGS AND ASSEMBLY/USE INSTRUCTIONS. KEEP THIS GUIDE FOR FUTURE REFERENCE.

- ADULT ASSEMBLY REQUIRED. The product contains small parts, which are for adult assembly only. keep small children away when assembling.
- always remove protective material and poly bags and dispose before assembly.
- never leave child unattended. direct adult supervision is required.
- always keep child in view when child is in vehicle.
- Keep Children within Safe Riding Areas:
 - Never use in roadways, near motor vehicles, on lawn space, on or near steep inclines or steps, swimming pools or or any other dangerous area.
 - Use the toy only on flat surfaces. Such as inside your house, garden or playground.
 - Never use in the dark. A child could encounter unexpected obstacles and have an accident. Operate the vehicle only in the daytime or a well-lit area.
 - always wear shoes.
 - always sit on the seat.
 - this toy has no brake.
 - It is prohibited to change the circuit or add other electric parts
 - Inspect wires and connections of the vehicle periodically.
 - Do not let any child touch the wheels or be near them when the car is moving.
 - This vehicle has adjustable play seat belts. Please instruct children how to tie the safety belt before using, guarantee the security.

STORAGE BATTERY INFORMATION AND MAINTENANCE

- Please charge 8 to 12 hours before first time use.
- Please use the suitable adapter to charge storage battery, otherwise the ride-on will be damaged.
- Please charge the car once the speed is slower than normal, otherwise it will decrease storage battery life.
- Please fully charge the battery before you put your ride-on away, and remember to recharge the battery every 30 days. This will ensure the normal use of the battery, otherwise, the battery might not hold a charge without proper maintenance.
- Batteries may leak fluids that can cause chemical burn injury or ruin your product.
- To avoid battery leakage: Do not mix old and new batteries or batteries of different types: alkaline, standard (carbon-zinc) or rechargeable (nickel-cadmium).
- Insert batteries as indicated inside the battery compartment. Remove batteries during long periods of non-use.
- Always remove exhausted batteries from the product. Dispose of batteries safely. Do not dispose of batteries in a fire. The batteries may explode or leak.
- Never short-circuit the battery terminals.
- Non-rechargeable batteries are not to be recharged.
- Use only batteries of the same or equivalent type as recommended.
- Do not charge non-rechargeable batteries.
- Remove rechargeable batteries from the product before charging.
- If removable rechargeable batteries are used, they are only to be charged under adult supervision
- Every single charging can not go over 10 hours. Both charger and storage batteries will occur mildly warm during charging. Do not use mal-functioned adapter or storage battery unless they are repaired.
- Charger and storage batteries are not considered as toys.
- Please make periodical inspection for storage battery, especially for adapter wires and plugs.
- Please turn off the switch when the ride-on is not in use. Please do a full charge after long periods of inactivity.
- Charge in well ventilated, dry place. Do not open the battery or the charger.
- Tighten the screws with a screwdriver. DO NOT over tighten

Disposal Of Battery:

1. Your sealed lead-acid battery must be recycled or disposed of in an environmentally sound manner.
2. Do not dispose of your lead-acid battery in a fire. The battery may explode or leak.
3. Do not dispose of a lead-acid battery in your regular, household trash. The incineration, land filling or mixing of sealed lead-acid batteries with house-hold trash is prohibited by law.

PREVENT FIRE AND ELECTRIC SHOCK:

- Use the only rechargeable battery and charger supplied with your vehicle.
- NEVER substitute the battery or the charger with another brand. Using another battery or charger may cause a fire or explosion.
- Do not use the battery or charger for any other product. Overheating, fire or explosion could occur.
- NEVER modify the electric circuit system. Tampering with the electric system may cause a shock, fire or explosion or may permanently damage the system.
- Do not allow direct contact between battery terminals. Fire or explosion can occur.
- Do not allow any type of liquid on the battery or its components.
- Explosive gasses are created during charging. Do not charge near heat or flammable materials. Charge the battery in a well- ventilated area ONLY.
- NEVER pick up the battery by the wires or charger. Damage can occur to the battery and may cause a fire. Pick up the battery by the case ONLY.

Charge the battery in a dry area ONLY.

●Battery posts, terminals and related accessories contain lead and lead compounds, chemicals known to the State of California to cause cancer and reproductive harm. Wash hands after handling.

●Do not open the battery. Battery contains lead acid and other materials that are toxic and corrosive.

●Do not open the charger. Exposed wiring and circuitry inside case may cause electric shock.

ONLY adults may handle or charge the battery. NEVER allow child to handle or charge the battery. Battery is heavy and contains lead acid (electrolyte).

●Do not drop the battery. Permanent damage to the battery could occur or cause serious injury.

●Before charging the battery, check for wear or damage to the battery, charger, its supply cord and the connectors. DO NOT charge the battery if any damage to parts has occurred.

Do not allow the battery to drain completely. Recharge the battery after each use or once a month if not used regularly.

●Do not charge battery upside down.

●Always secure the battery with the bracket. Battery can fall out and injure a child if vehicle tips over.

●It is parents' responsibility to check main parts of the toy before using, Must regularly examine for potential hazard, such as the battery, charge, cable or cord, plug, screws are fastening enclosure of other parts and that in the event of such damage, the toy must not be until that damage had been properly removed. Make sure the plastic parts of the vehicle are not cracked or broken.

●Occasionally use a lightweight oil to lubricate moving parts such as wheels.

●Park the vehicle indoors or cover it with a tarp to protect it from wet weather.

●Keep the vehicle away from sources of heat, such as stoves and heaters. Plastic parts may melt.





●Recharge the battery after each use. Only an adult can handle the battery. Recharge the battery at least once a month when the vehicle Raider is not being used.

●Do not wash the vehicle with a hose. Do not wash the vehicle with soap and water. Do not drive the vehicle in rainy or snowy weather. Water will damage the motor, electric system and battery.

●Clean the vehicle with a soft, dry cloth. To restore shine to plastic parts, use a non-wax furniture polish. Do not use car wax. Do not use abrasive cleaners.

●Do not drive the vehicle in loose dirt, sand or fine gravel which could damage moving parts, motors or the electric system.

●When not using, all the electrical source should be turn off. Turn off the power switch and disconnect the battery connection.

 <p>A x 1 Car body</p>	 <p>B x 1 Handlebar</p>	 <p>C x 1 Front fork</p>	
 <p>D x 3 Wheel</p>	 <p>E x 1 Driving wheel</p>	 <p>F x 1 Steering lever</p>	
 <p>G x 1 Rear axle</p>	 <p>H x 1 Motor</p>	 <p>I x12 Washer</p>	 <p>J x 4 M8 Screw nut</p>
 <p>K x 6 M4*10 Screw</p>	 <p>L x 1 Cotter pin</p>	 <p>M x 2 Wrench</p>	 <p>N x 1 Charger</p>



How to assemble

1. How to assemble front fork

Turn the car over, then insert the front fork into the right place. Use 2pcs M4*10 screw to tighten front guard and front fork. Use 2pcs M4*10 screw to tighten front fork and car body.



2. How to assemble front wheel

Insert 1pcs washer to the bottom of the steering lever. Insert the steering column into the hole. Move the washer up to the hole of cotter pin, then use snap-pin to tighten.



3. How to assemble front wheel

Add washer, front wheel, washer one by one to front axle, use M8 screw nut to tighten. The other side in the same way.

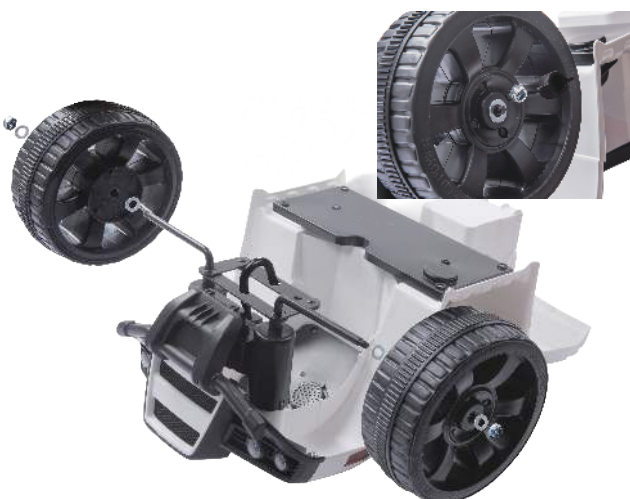

4. How to assemble back wheel

Add 1pcs washer from the long side of rear axle, then insert the rear axle to the car body from the right side. Add motor, driving wheel and 1pcs washer to the left side one by one, then add 1pcs washer, wheel, 1pcs washer to the right side one by one, finally use 2pcs M8 screw nut to tighten.

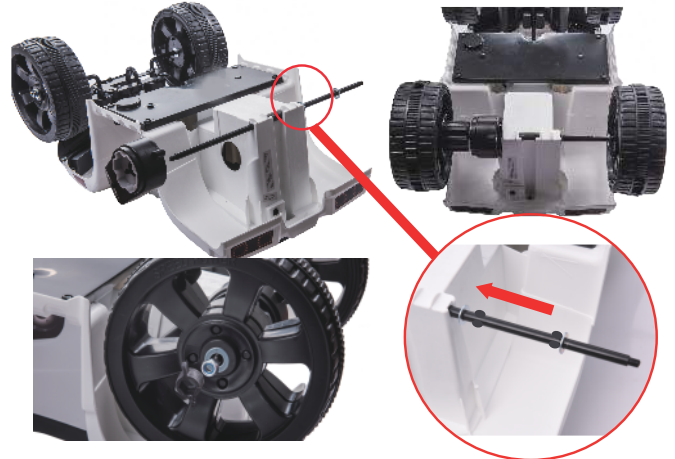

5. Connect the lines

Connect motor line and battery line first. Then turn on the power to check line connected right or not.

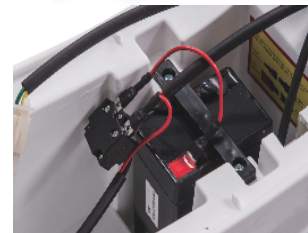

6. How to assemble handlebar

Straighten the wheel, then insert the handlebar to the steering lever (please match the shape), it is assembled correctly when hear "Click".



Function show



Button function

- ① Barometric horn
- ② Forward/ Backward
- ③ Power
- ④ Pedal

Problem solution

Problem	Analysis	Solution
	Battery low power Fuse protect	Charge battery Reuse a few minutes later
Car can not move	Power not turn on Battery line loose Battery damaged Electric device damaged Motor damaged	Turn on it again Reconnect Replace a new one Replace a new one Replace a new one
Battery can not be recharged	Battery connector loose Charger not plug in Chager damages	Reconnect Replug Replace a new one
Car does not run very long	Battery power low Battery is old	Recharge Replace a new one
Charger feels warm when charging	Chemical reaction	Normal
Speed slow	Battery is old Battery power low Overloaded Road is not even	Replace a new one Recharge Reduce weight under 25KG Play in a smooth area

Charging notification

- For the first use, please charge 10 hours, or will damage the battery.
- Plug charger DC line into charge hole first, then plug charger into socket. Car can not be played when it charging.
- Every time it charged, do not charge more than 18 hours. It is normal that charger and battery warm (under 60°) during charging.
- Do not charge if plug is wet, or will occur short-circuited.
- Only use charger provided by manufacturer, or will damage charger and battery or occur short-circuited.
- If long time no use, please charge 1 time per month at least.

Charging step

- Step 1: Charge hole is under the seat.
- Step 2: Plug charger DC line into charge hole.
- Step 3: Plug charger into socket.



Warning: Car must be charged by adults only. Car is useless during charging.

Maintenance instruction

- Check battery, charger and other spare parts regularly. If any problem, please fix it before playing.
- Use lubricating oil to care iron parts. Keep car away from fire and sunshine. Park it on the even place, not reversal or gradient.
- Park it indoor and cover it with waterproof cloth.
- Keep car away from fire, like stove or heater, or plastic may melt. Keep away from flammable things, or may occur fire accident.
- Charge it after use and must be done by adults only. If long time no use, please charge it 1 time per month, in order to maintain battery.
- Clean the vehicle with a dry cloth only. Do not use chemical solvent to wipe plastic parts. Do not wash it with water or play it when raining or snowing. Water will damage motor, electric system or battery.
- Please turn power off after each use.
- Only use charger provided by manufacturer.
- Do not change car's structure or electric line. Check job request some skills or under specialist's guidance.

Contact US

If you have any questions, please contact our customer care center.

Our contact details are below:



0044-800-240-4004



enquiries@mhstar.co.uk

IMPORTER ADDRESS:
MH STAR UK LTD
Unit 27, Perivale Park,
Horsenden lane South
Perivale, UB6 7RH
MADE IN CHINA