

PawHut

IN230300088V01_GL

D00-123



EN_ IMPORTANT, RETAIN FOR FUTURE REFERENCE: READ CAREFULLY.

FR_ IMPORTANT: A LIRE ATTENTIVEMENT ET À CONSERVER POUR CONSULTATION ULTÉRIEURE.

ES_ IMPORTANTE, LEA Y GUARDE PARA FUTURAS REFERENCIAS.

PT_ IMPORTANTE, RETER PARA REFERÊNCIA FUTURA: LEIA ATENTAMENTE.

DE_ WICHTIG! SORGFÄLTIG LESEN UND FÜR SPÄTER NACHSCHLAGEN AUFBEWAHREN.

IT_ IMPORTANTE! CONSERVARE IL PRESENTE MANUALE PER FUTURO RIFERIMENTO E LEGGERLO ATTENTAMENTE.

EN

Dear customer,

Thank you for purchasing this product. So that your appliance serves you well, please read all the instructions in this user's manual. If you have any questions, please contact our customer care center, Our contact details are below:

FR

Cher client,

Nous vous remercions d'avoir acheté ce produit. Afin que vous puissiez profiter pleinement de votre appareil, veuillez lire toutes les instructions de ce manuel d'utilisation. Si vous avez la moindre question, veuillez contacter notre centre d'assistance à la clientèle, Nos coordonnées sont les suivantes:

DE

Sehr geehrter Kunde,

Vielen Dank, dass Sie dieses Produkt erworben haben. Damit Ihr Gerät Ihnen gute Dienste leistet, lesen Sie bitte alle Hinweise in diesem Benutzerhandbuch. Wenn Sie Fragen haben, wenden Sie sich bitte an unser Kundendienstzentrum, Unsere Kontaktdaten stehen unten:

ES

Queridos clientes,

Gracias por comprar este producto. Para que su electrodoméstico le sirva mejor, lea todas las instrucciones de este manual del usuario. Si tiene alguna pregunta, comuníquese con nuestro Centro de Atención al Cliente, Nuestros datos de contacto son los siguientes:

PT



Caros clientes,

Obrigado por adquirir este produto. Para que o seu aparelho o sirva melhor, leia todas as instruções deste manual do utilizador. Se tiver alguma dúvida, por favor contacte o nosso Centro de Atendimento ao Cliente, Os nossos dados de contacto são os seguintes:

IT

Caro Cliente,

Grazie per aver acquistato questo prodotto. Per servirti meglio con questo apparecchio ti prego di leggere tutte le istruzioni in presente manuale utente. In caso di dubbio, si prega di contattare il nostro centro assistenza clienti, I nostri dettagli di contatto sono di seguito:

Country	 Phone	 Email
US	001-877-644-9366	customerservice@aosom.com
CA	416-792-6088	customerservice@aosom.ca
UK	0044-800-240-4004	enquiries@mhstar.co.uk
DE	0049-0(40)-88307530	service@aosom.de
FR	0033-1-84166106	aosom@mhfrance.fr
ES	0034-931294512	atencioncliente@aosom.es
PT	0034-931294512	info@aosom.pt
IT	0039-0249471447	clienti@aosom.it

US

Imported by Aosom LLC
27150 SW Kinsman Rd Wilsonville, OR 97070 USA
MADE IN CHINA

CA

Imported by Aosom Canada Inc.
1251 Tapscott Road, Unit 101, Scarborough, Ontario Canada M1X 1S9
MADE IN CHINA

Importé par Aosom Canada Inc.
1251 Rue Tapscott, Unité 101, Scarborough, Ontario Canada M1X 1S9
FABRIQUÉ EN CHINE

EN

IMPORTER ADDRESS:
MH STAR UK LTD
Unit 27, Perivale Park,
Horsenden lane South
Perivale, UB6 7RH
MADE IN CHINA

FR

ADRESSE D'IMPORTATION:
MH FRANCE
2 Rue Maurice Hartmann
92130 Issy Les Moulineaux
France
FABRIQUÉ EN CHINE

ES

IMPORTADOR:
SPANISH AOSOM, S.L.
C/ROC GROS,Nº15.08550, ELS HOSTALETS DE BALENYÀ, SPAIN.
B66295775
WWW.AOSOM.ES
ATENCIONCLIENTE@AOSOM.ES
TEL: 931294512
HECHO EN CHINA

PT

SPANISH AOSOM, S.L
C.ROC GROS N.15, 08550. ELS HOSTALETS DE BALENYÀ
TEL: 931294512 (SEG-SEX DAS 7:30H ÀS 16:30H)
INFO@AOSOM.PT
WWW.AOSOM.PT

DE

ADRESSE DES IMPORTEURS:
MH Handel GmbH
Wendenstraße 309
D-20537 Hamburg
Germany
IN CHINA HERGESTELLT

IT

IMPORTATO DA:
AOSOM Italy srl
Centro Direzionale Milanofiori
Strada 1 Palazzo F1
20057 Assago (MI)
P.I.: 08567220960
FATTO IN CINA

1.Handle

2.Cradle

3.Rear wheel

**4.Front
wheel**



Operation frame

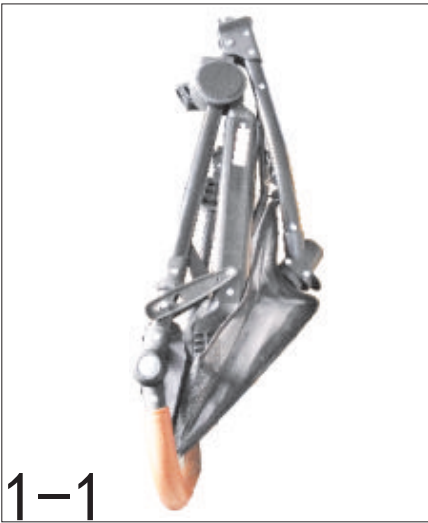

* Open the box, take the frame and all parts from the bag, pull up the handle as picture 1-1.

* Keep pulling the handle upward till sound click.
ASSEMBLE PET BAG



* Open two supporting wires as figure 2-1.

* Put the safety belts through the holes, then fasten the velcro as figure 2-2.

* Close the canopy by zipper as figure 2-3.

Assemble front wheels

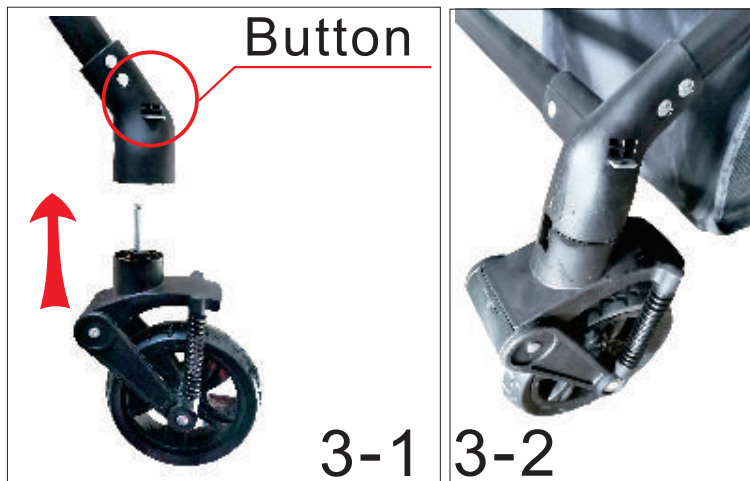

* Put on front wheels: push the front wheels on the frame till sound click as picture 3-1.

* Remove front wheels: press down the button as picture 3-1, while pulling up the stroller by another hand as picture 3-2.

Assemble rear wheels

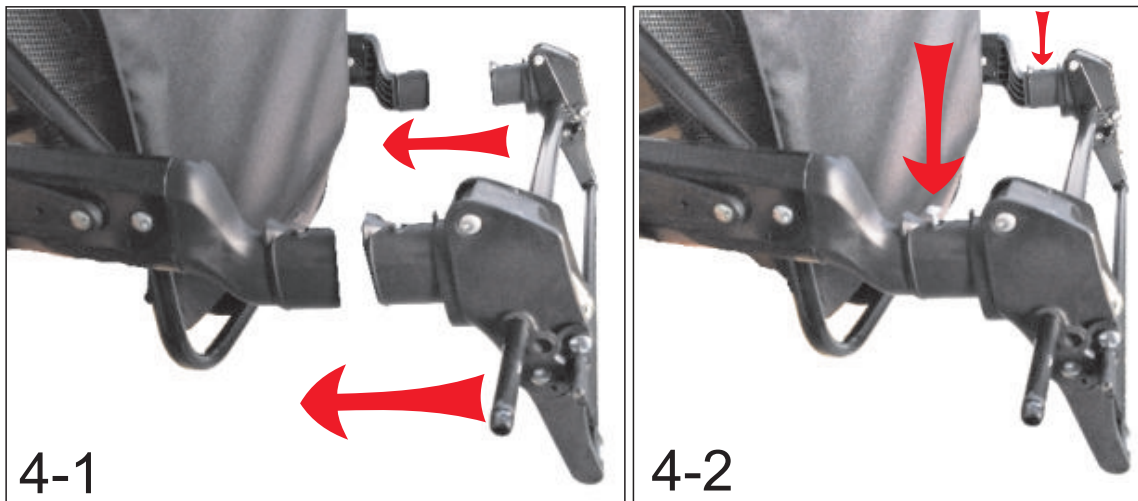

* Install the rear wheel mount, and then lock the screws.

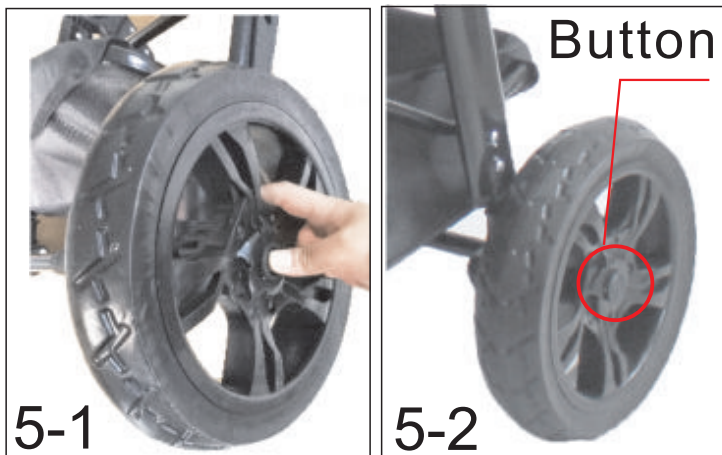

* Pressing down the button in the centre of wheels, put on the axle
Open the net part .



* Open and close the net part through zip as picture 6.

Brake



* Brake rear wheels: step down the brake rode can park the stroller; pull upward the brake rod to unlock.

Install the pet cage

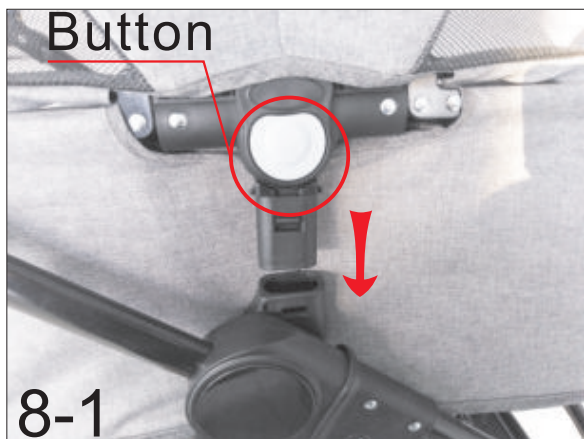

* Install the pet cage: Hold the pet cage by both hands and insert the connector joint into the socket till a sound "click" as picture 8-1. Then install the fixing hook

Folding product

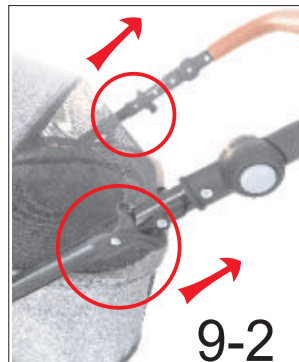
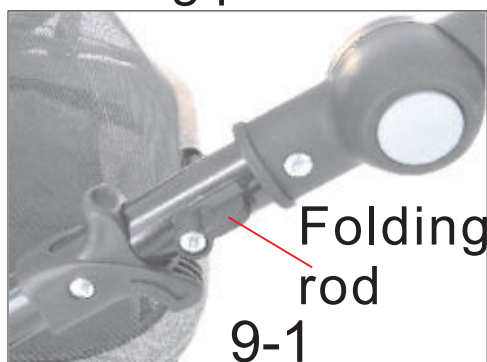

* Rotate the folding bar as shown in the figure, Pull up the connectors on both side of stroller at same time, press down the handle.

Safety belt

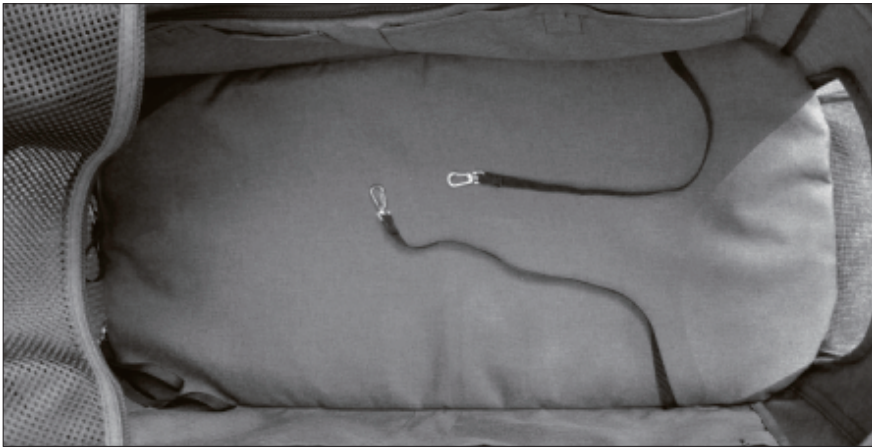

*Please use safety belt while the pet is in cradle.

Adjusting handle

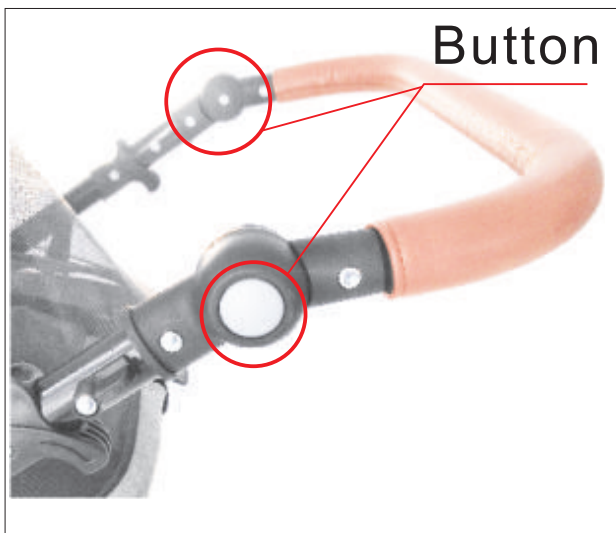

* Press down the buttons on both side of handle and then adjust

▲WARNING:

1. For pets only.
2. Do not leave pet in stroller unattended.
3. Always apply the brake whenever the stroller is stationary.
4. The maximum weight capacity is 25kg.
5. Do not use any component not supplied by manufacturer.

Cleaning and maintenance:

1. Unsnap button on stroller;
2. Take apart the canopy;
3. Take out the cushion;
4. Wipe stroller slightly.

1. Poignée

2. berceau

3. roue arrière

4. roue avant



Cadre de fonctionnement



1-1



1-2

* Ouvrez la boîte, sortez le cadre et toutes les pièces du sac, tirez la poignée vers le haut comme sur l'image 1-1.

* Continuez à tirer la poignée vers le haut jusqu'à ce que vous entendiez un déclic. —

ASSEMBLER LE SAC POUR ANIMAUX DE COMPAGNIE



2-1



2-2



2-3

* Ouvrez les deux câbles de soutien (figure 2-1).

* Passez les ceintures de sécurité dans les trous, puis fixez le velcro (figure 2-2).

* Fermez la capote à l'aide de la fermeture éclair (figure 2-3).

Assemblage des roues avant

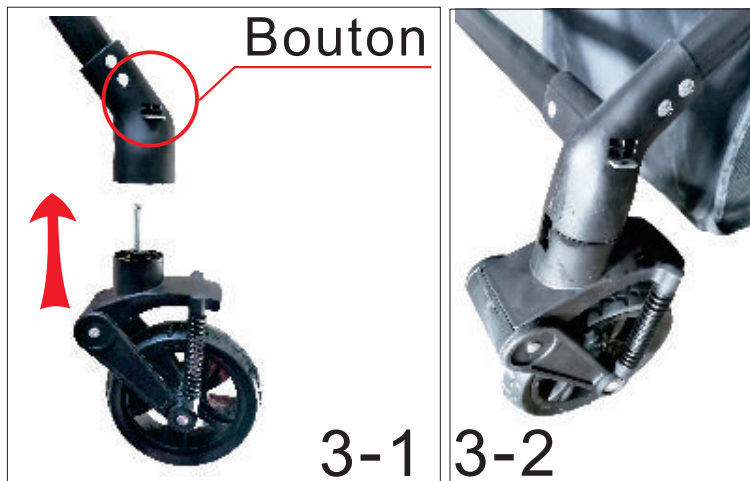

* Mettre les roues avant : pousser les roues avant sur le châssis jusqu'au clic sonore comme sur l'image 3-1.

* Enlever les roues avant : appuyer sur le bouton comme sur l'image 3-1, tout en tirant la poussette d'une autre main comme sur l'image 3-2.

Assembler de vraies roues

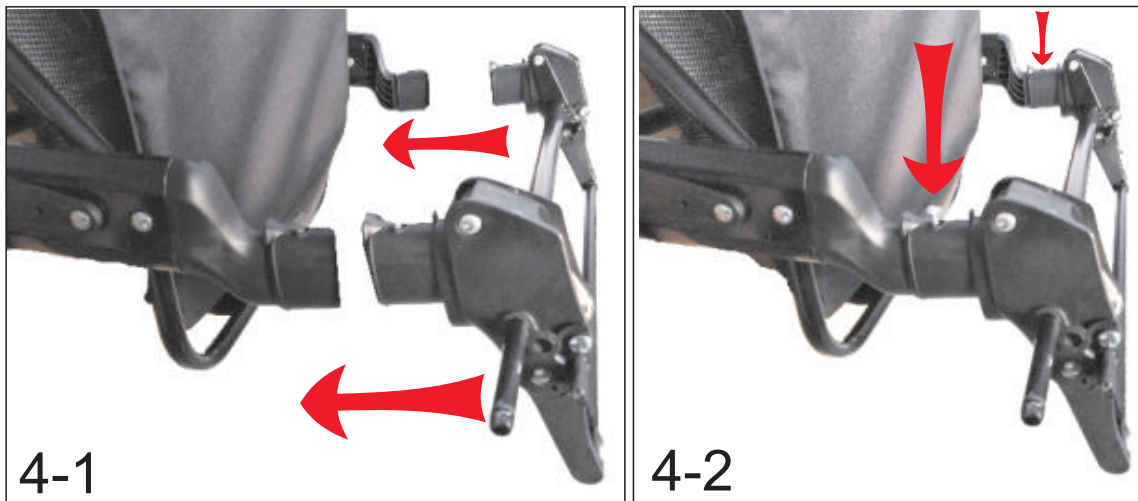

* Installez le support de la roue arrière, puis verrouillez les vis.

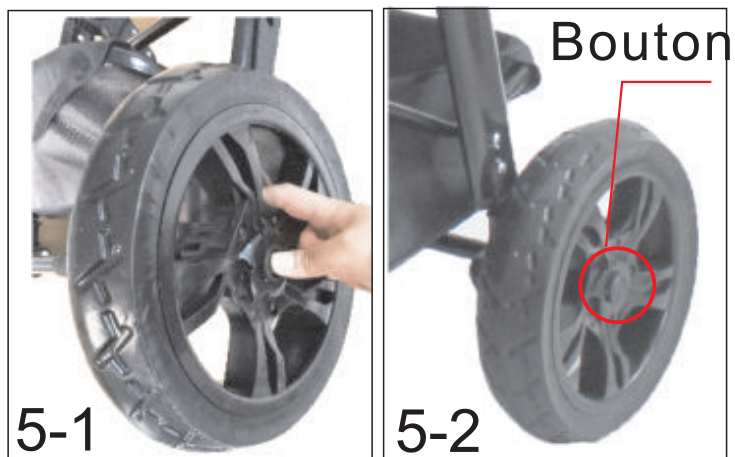

* Appuyer sur le bouton au centre des roues, mettre en place l'axe. Ouvrir la partie filet .



*Ouvrez et fermez la partie filet par la fermeture éclair, comme sur l'image 6.

Frein



* Freiner les roues arrière : descendre la tige de frein pour garer la poussette ; tirer la tige de frein vers le haut pour déverrouiller.

Installer la cage pour animaux de compagnie

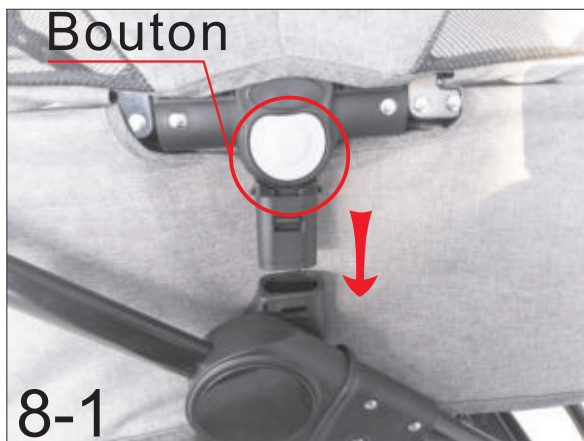

* Installer la cage de l'animal : Tenez la cage à deux mains et insérez le connecteur dans la prise jusqu'à ce que vous entendiez un "clic", comme sur l'image 8-1.

Produit pliable

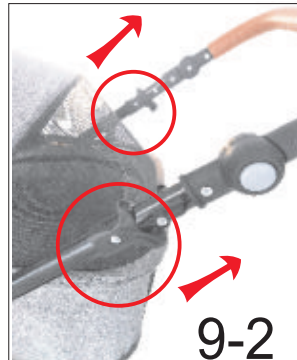
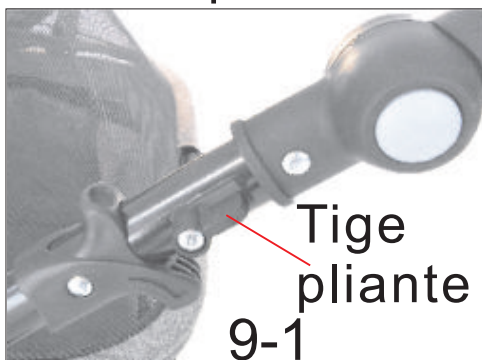

* Tourner la barre de pliage comme indiqué sur la figure, tirer vers le haut les connecteurs des deux côtés de la poussette en même temps, appuyer sur la poignée.

Ceinture de sécurité

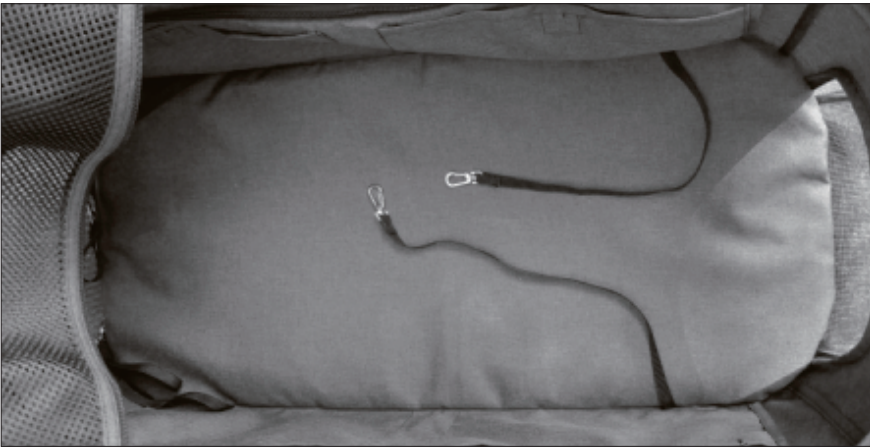

*Veuillez utiliser la ceinture de sécurité lorsque l'animal est dans le berceau.

Poignée de réglage

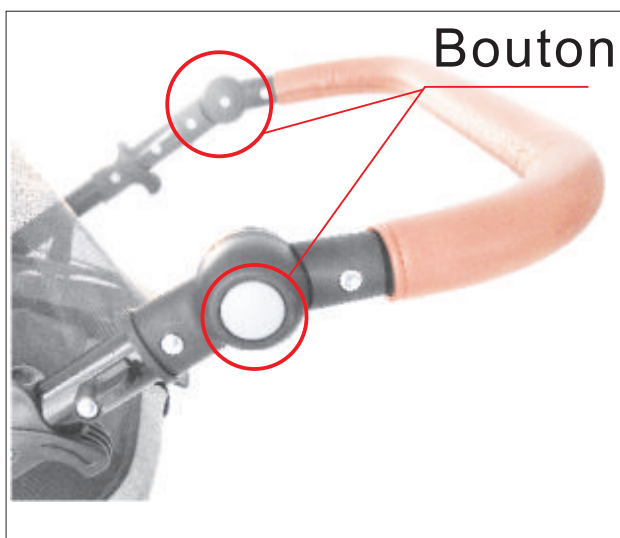

* Appuyer sur les boutons situés de part et d'autre de la poignée, puis ajuster.

▲ AVERTISSEMENT :

1. pour les animaux domestiques uniquement.
2. Ne pas laisser l'animal dans la poussette sans surveillance.
3. Toujours appliquer le frein lorsque la poussette est à l'arrêt.
4. la capacité de poids maximale est de 25 kg.
5. ne pas utiliser de composants non fournis par le fabricant.

Nettoyage et entretien :

1. débloquer le bouton de la poussette ;
2. démonter la capote
3. retirer le coussin ;
4. essuyer légèrement la poussette.

1.Mango

2.Cuna

3.Rueda trasera

4.Rueda delantera



Marco operativo

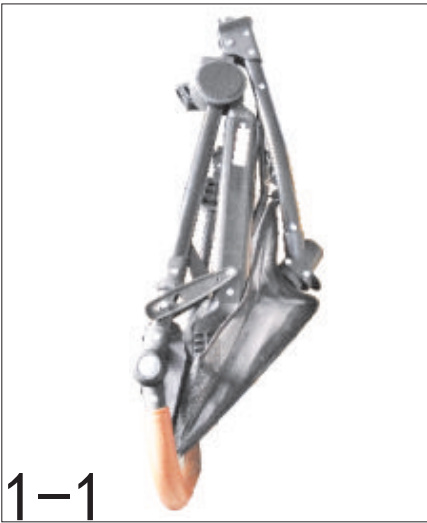

1-1



1-2

* Abra la caja, saque el marco y todas las piezas de la bolsa pe, tire del asa hacia arriba como en la imagen 1-1. * Siga tirando del asa hacia arriba hasta que suene un clic.

* Siga tirando del asa hacia arriba hasta que suene un clic.

MONTAR LA BOLSA PARA MASCOTAS



2-1



2-2



2-3

* Abra los dos cables de soporte como se muestra en la figura 2-1.

* Pase los cinturones de seguridad por los orificios y fije el velcro como se muestra en la figura 2-2.

* Cierre la capota con la cremallera como se muestra en la figura 2-3.

Montar las ruedas delanteras

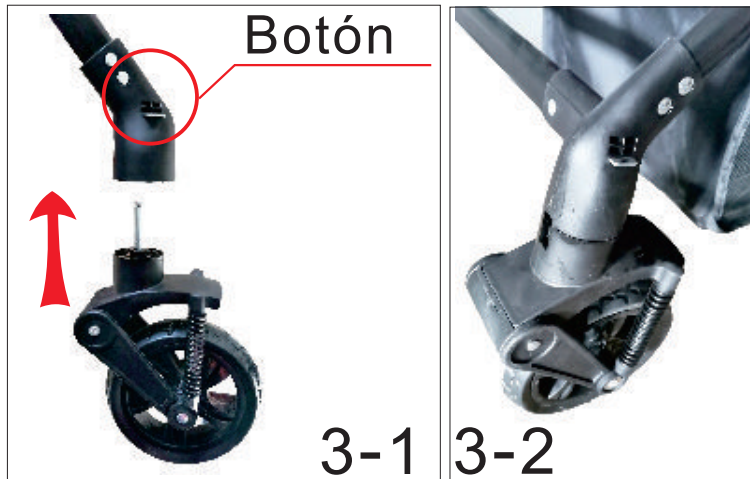

* Coloque las ruedas delanteras: empuje las ruedas delanteras en el chasis hasta que suenen como en la imagen 3-1.

* Quite las ruedas delanteras: pulse el botón como en la imagen 3-1, mientras tira del cochecito con otra mano como en la imagen 3-2.

Montar ruedas reales

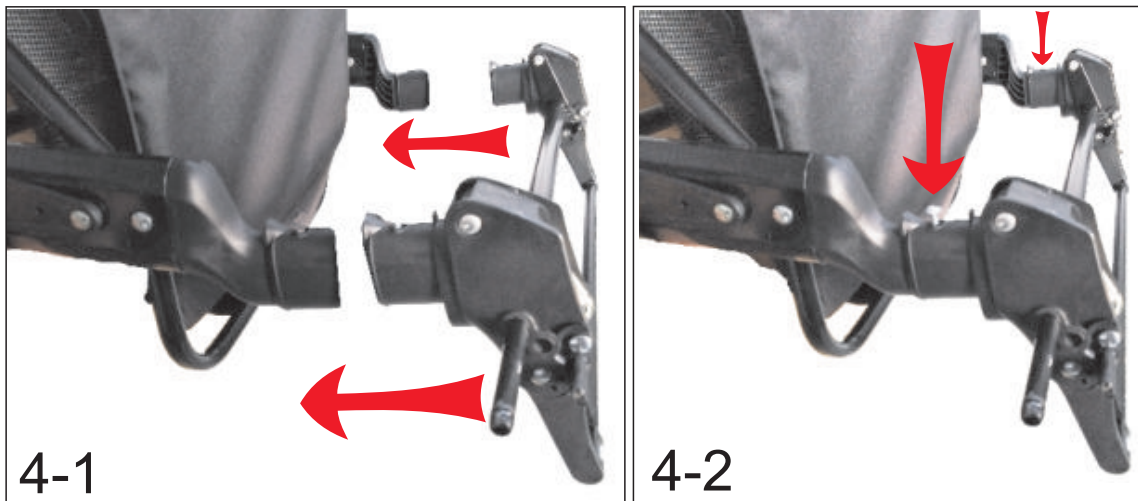

*Instale el soporte de la rueda trasera y, a continuación, bloquee los tornillos.

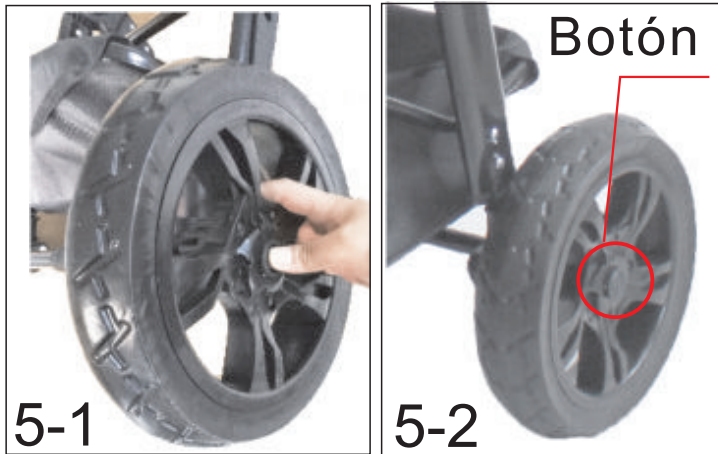

* Presionando el botón en el centro de las ruedas, coloque el eje.
Abrir la parte de la red .



* Abra y cierre la parte de red mediante cremallera como en la imagen 6.

Freno



* Freno de las ruedas traseras: bajando la barra de freno se puede aparcar el cochecito; tirando hacia arriba de la barra de freno se desbloquea.

Instalar la jaula

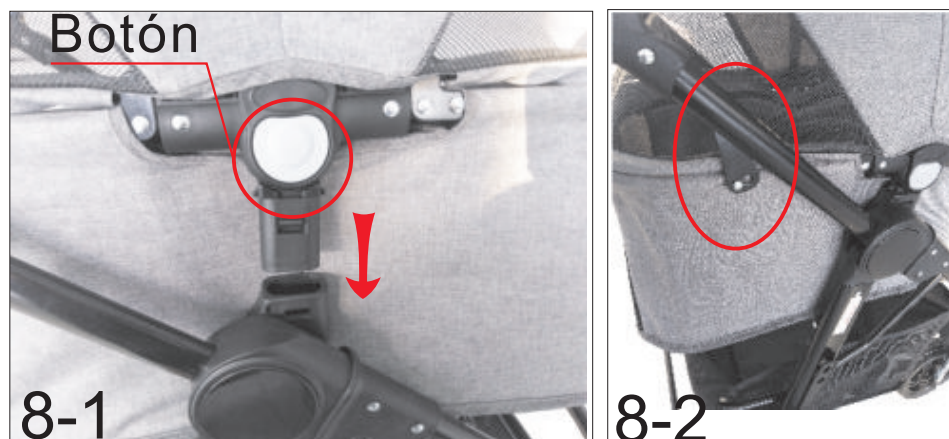

* Instale la jaula: Sujete la jaula con ambas manos e inserte el conector en el enchufe hasta que se oiga un "clic", como se muestra en la imagen 8-1. A continuación, instale el gancho de fijación.

Producto plegable

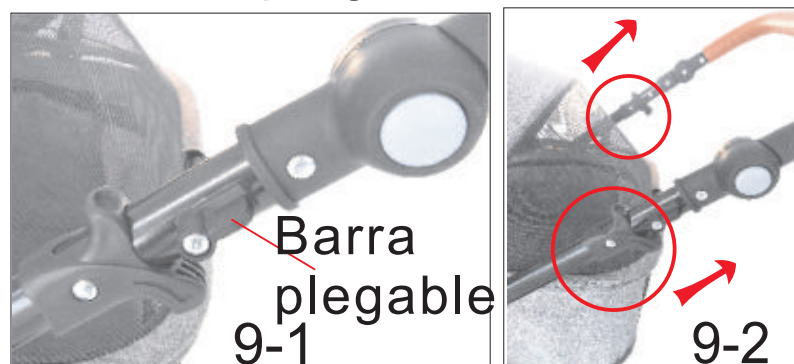

*Gire la barra de plegado como se muestra en la figura, tire hacia arriba de los conectores de ambos lados del cochecito al mismo tiempo, presione hacia abajo el asa.

Cinturón de seguridad

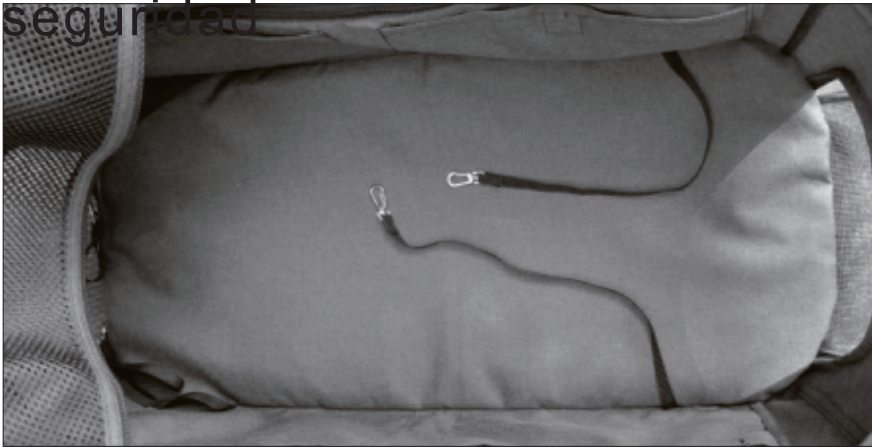

*Por favor, utilice el cinturón de seguridad mientras la mascota esté en la cuna.

Asa de ajuste

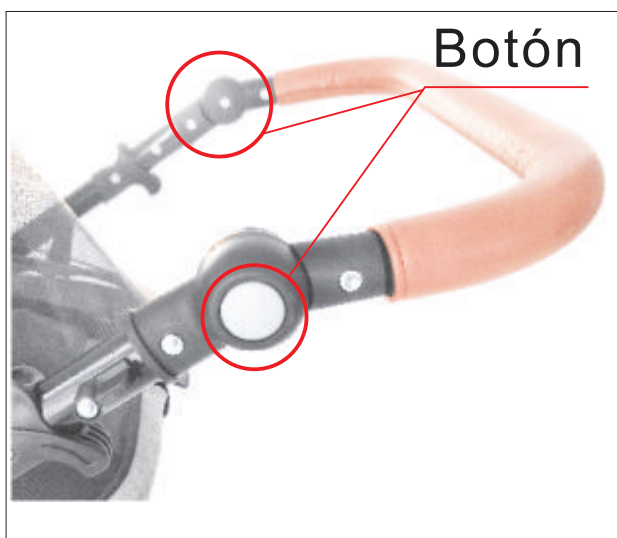

* Presione los botones de ambos lados de la empuñadura y, a continuación, ajuste

ADVERTENCIA:

1. Sólo para mascotas.
2. No deje a su mascota desatendida en el cochecito.
3. Ponga siempre el freno cuando el cochecito esté parado.
4. La capacidad máxima de peso es de 25 kg.
5. No utilice ningún componente no suministrado por el fabricante.

Limpieza y mantenimiento:

1. Desenganche el botón del cochecito;
2. Desmonte la capota;
3. Saque el cojín;
4. Limpie ligeramente el cochecito.

1.Manusear

2.Berço

3.Roda traseira

**4.Roda
dianteira**



Estrutura de operação



1-1



1-2

*Abrir a caixa, tirar a moldura e todas as partes do saco do pe, puxar para cima a pega como figura 1-1.

*Puxe a pega para cima até ao clique sonoro.
MONTAR O SACO DE ANIMAIS DE ESTIMAÇÃO



2-1



2-2



2-3

* Abra dois fios de suporte como figura 2-1.

* Coloque os cintos de segurança através dos orifícios, depois aperte o velcro como figura 2-2.

* Fechar o dossel com zíper, como figura 2-3.

Montar rodas frontais

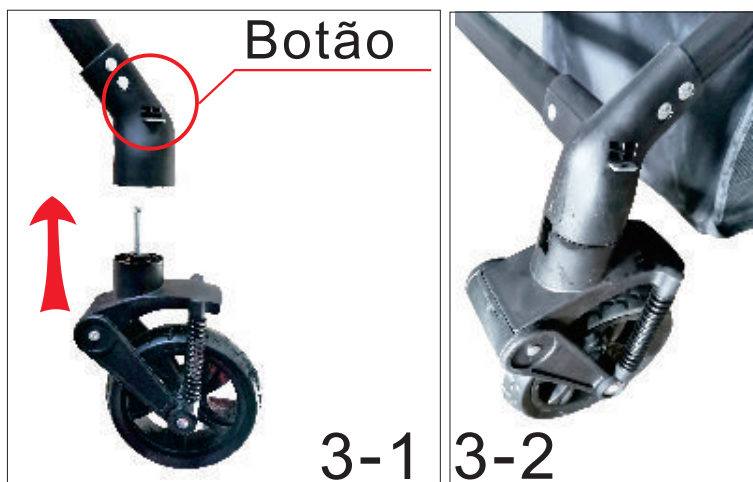

* Colocar as rodas dianteiras: empurrar as rodas dianteiras sobre a moldura até que o som clique como imagem 3-1.

* Retirar as rodas dianteiras: premir o botão como figura 3-1, enquanto se puxa o carrinho de bebê por outra mão como figura 3-2.

Montagem de rodas reais

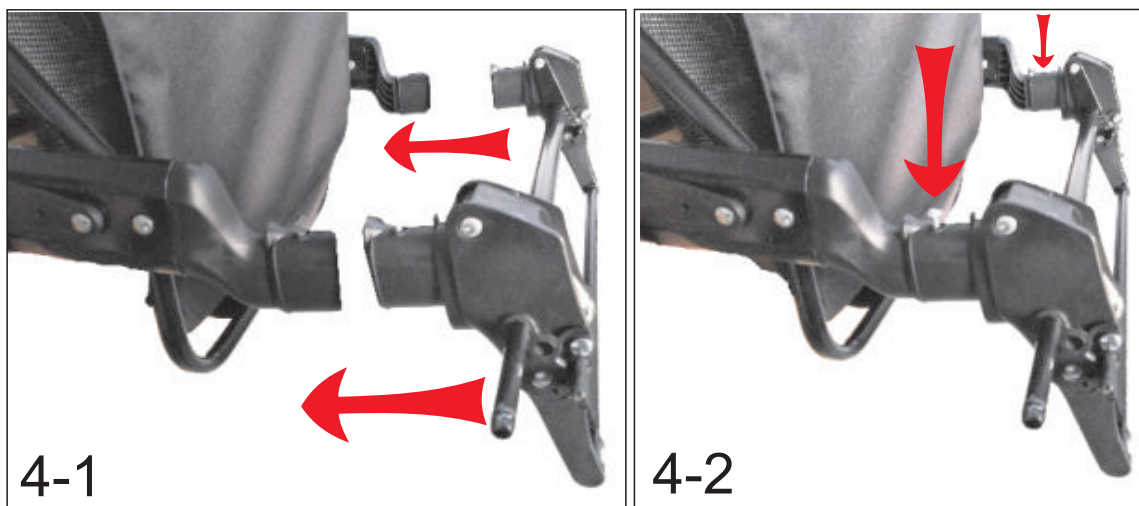

*Instalar o suporte da roda traseira, e depois bloquear os parafusos.

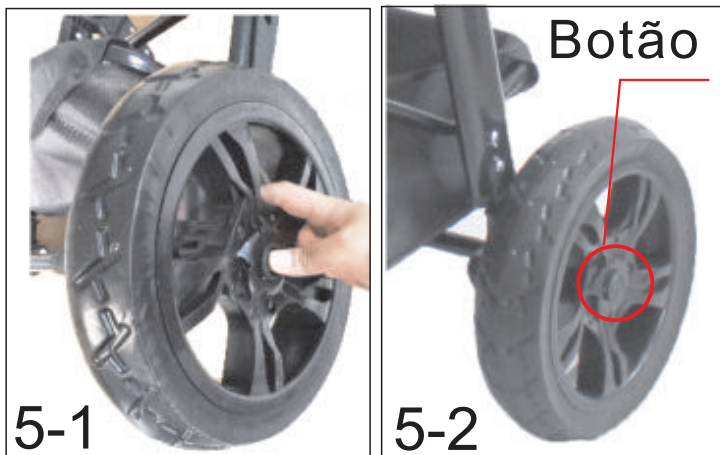

* Premindo o botão no centro das rodas, colocado sobre o eixo
Abrir a parte da rede .



*Abrir e fechar a parte da rede através do fecho de correr como imagem 6.

Travão



* Rodas traseiras de travão: descer o travão montado pode estacionar o carrinho; puxar a haste do travão para cima para desbloquear.

Instalar a gaiola para animais de estimação

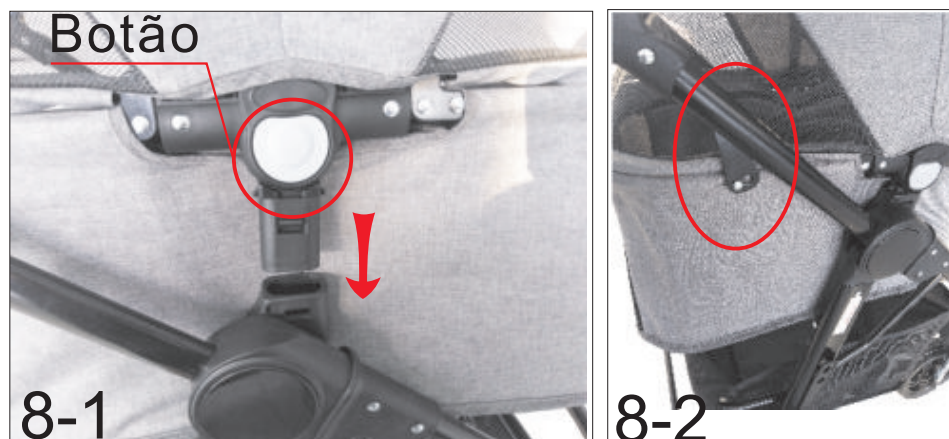

* Instalar a gaiola para animais de estimação: Segurar a gaiola do animal de estimação com ambas as mãos e inserir a articulação do conector na tomada até um "clique" sonoro como na figura 8-1.

Produto dobrável



*Rota a barra dobrável como mostra a figura, Puxe para cima os conectores de ambos os lados do carrinho de passeio ao mesmo tempo, pressione para baixo a pega.

Cinto de segurança

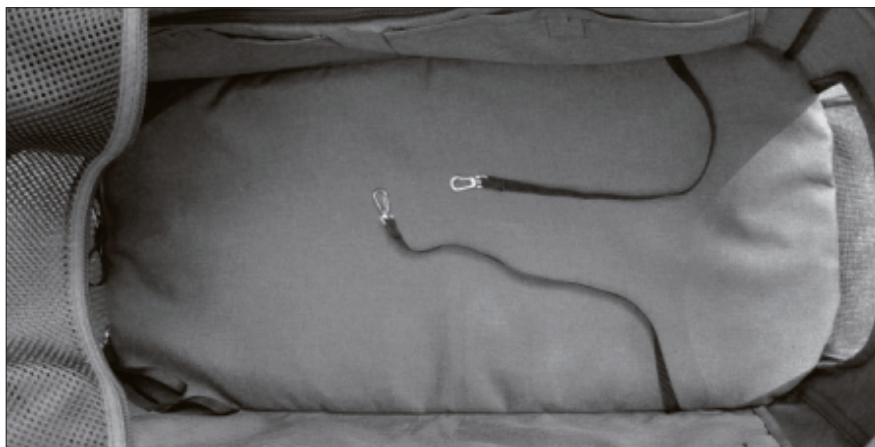

*Por favor, usar cinto de segurança enquanto o animal de estimação está no berço.

Pega de ajuste

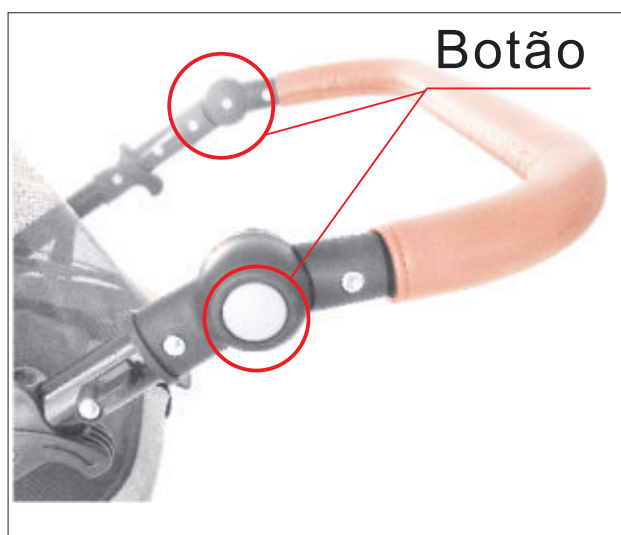

* Pressione para baixo os botões de ambos os lados da pega e depois ajuste

▲WARNING:

- 1.apenas para animais de estimação.
- 2.Não deixar o animal de estimação no carrinho de bebé sem vigilância.
- 3.Sempre que o carrinho de passeio estiver parado, accionar o travão.
- 4.A capacidade máxima de peso é de 25kg.
- 5.Não utilizar nenhum componente não fornecido pelo fabricante.

Limpeza e manutenção:

- 1.Botão de desembaciar no carrinho de passeio;
- 2.Desmontar o dossel;
3. desmontar a almofada;
4. limpar ligeiramente o carrinho de bebé.

1. Handgriff

2. wiege

3. hinteres Rad

**4. das
Vorderrad**



Rahmen der Operation



1-1



1-2

* Öffnen Sie den Karton, nehmen Sie den Rahmen und alle Teile aus der Tasche und ziehen Sie den Griff nach oben (siehe Abbildung 1-1).

* Ziehen Sie den Griff weiter nach oben, bis ein Klicken zu hören ist.

HAUSTIERTASCHE ZUSAMMENBAUEN



2-1



2-2



2-3

* Öffnen Sie zwei Stützdrähte wie in Abbildung 2-1 dargestellt.

* Stecken Sie die Sicherheitsgurte durch die Löcher und befestigen Sie dann den Klettverschluss wie in Abbildung 2-2.

* Schließen Sie das Verdeck mit dem Reißverschluss wie in Abbildung 2-3.

Vorderräder montieren

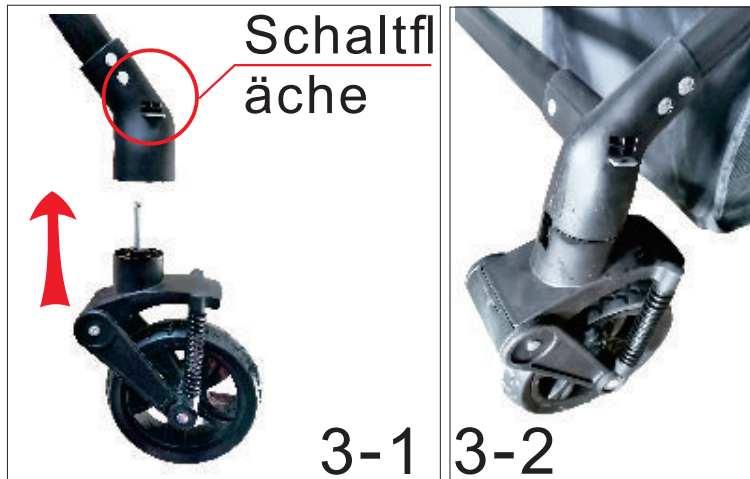

* Anbringen der Vorderräder: Schieben Sie die Vorderräder auf den Rahmen, bis ein Klickgeräusch zu hören ist (siehe Abbildung 3-1).

* Entfernen Sie die Vorderräder: Drücken Sie den Knopf wie in Abbildung 3-1, während Sie den Kinderwagen mit einer anderen Hand wie in Abbildung 3-2 hochziehen.

Echte Räder zusammenbauen

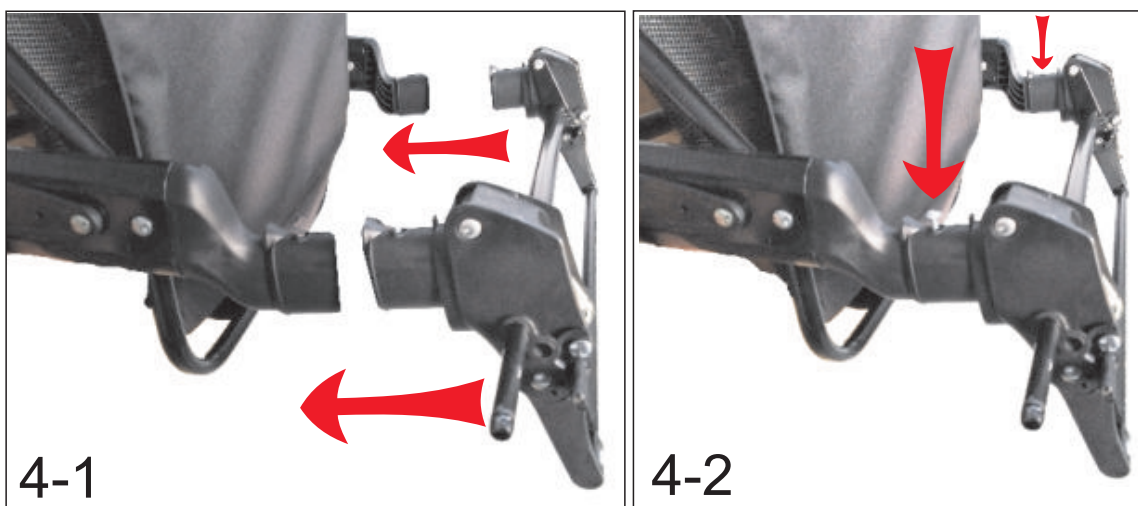

* Bauen Sie die Hinterradhalterung ein und sichern Sie die Schrauben.

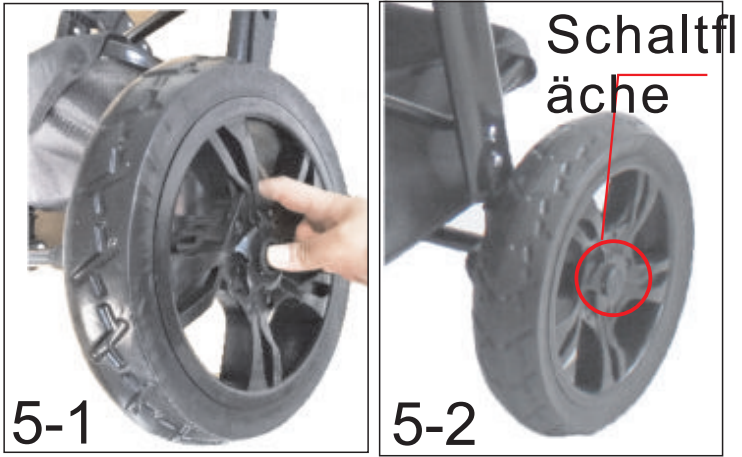

* Drücken Sie den Knopf in der Mitte der Räder, setzen Sie die Achse auf. Öffnen Sie das Netzteil.



*Öffnen und schließen Sie das Netzteil durch den Reißverschluss wie in Abbildung 6.

Bremse



* Bremse Hinterräder: Schritt nach unten die Bremse Rode kann der Kinderwagen parken; ziehen Sie die Bremse Stange nach oben zu entriegeln.

Installieren Sie den Käfig für Haustiere

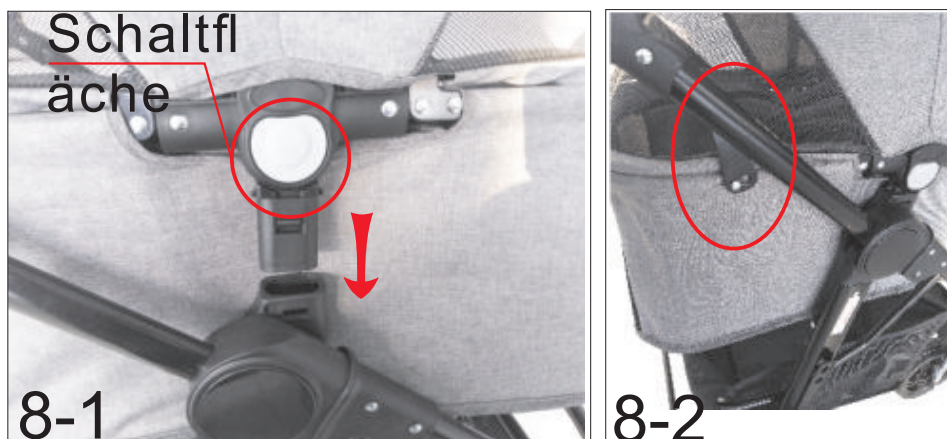

* Installieren Sie den Tierkäfig: Halten Sie den Käfig mit beiden Händen fest und stecken Sie das Verbindungsstück in die Buchse, bis ein Klickgeräusch zu hören ist (siehe Bild 8-1), dann installieren Sie den Befestigungshaken. Zusammenklappbares Produkt

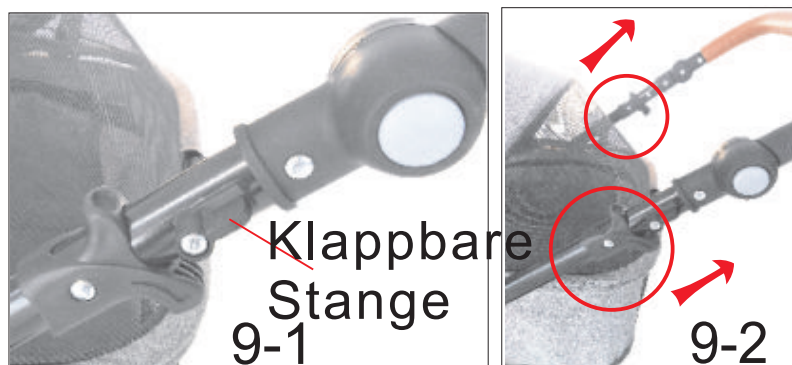

*Drehen Sie den Faltbügel wie in der Abbildung gezeigt, ziehen Sie die Verbindungsstücke an beiden Seiten des Kinderwagens gleichzeitig hoch und drücken Sie den Griff nach unten.

Sicherheitsgurt

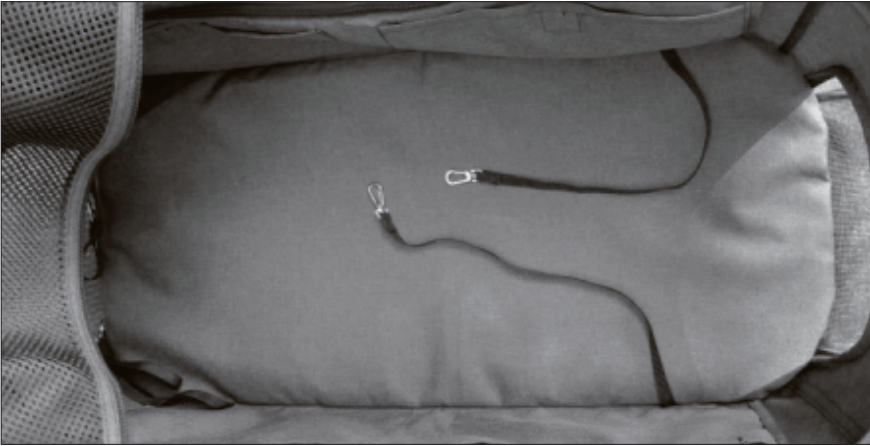

* Bitte legen Sie den Sicherheitsgurt an, während sich das Haustier in der Wiege befindet.

Verstellbarer Griff

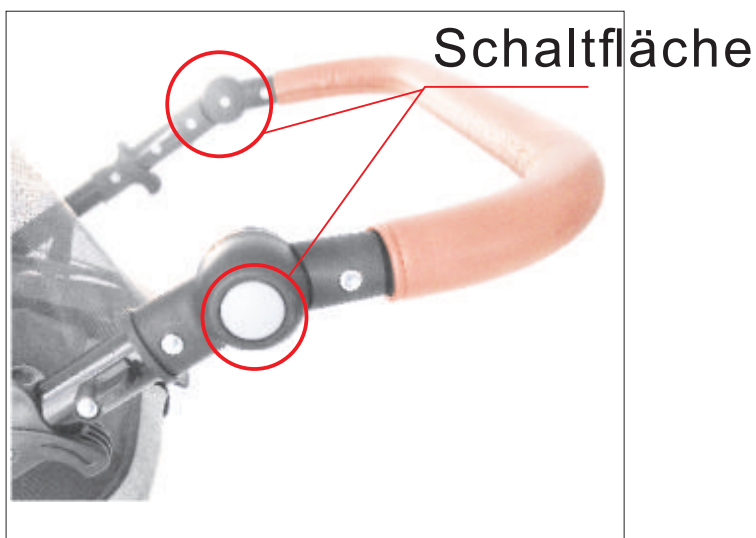

* Drücken Sie die Knöpfe auf beiden Seiten des Griffs und stellen Sie sie dann ein.

▲ WARNUNG:

1. nur für Haustiere.
2. lassen Sie Ihr Haustier nicht unbeaufsichtigt im Kinderwagen.
- 3) Ziehen Sie immer die Bremse an, wenn der Kinderwagen stillsteht.
4. die maximale Gewichtskapazität beträgt 25 kg.
5. verwenden Sie keine Teile, die nicht vom Hersteller geliefert wurden.

Reinigung und Wartung:

1. den Druckknopf des Kinderwagens lösen;
2. nehmen Sie das Verdeck ab;
3. nehmen Sie das Kissen heraus;
4. wischen Sie den Kinderwagen leicht ab.

1.Maniglia

2.Culla

**3.Ruota
posteriore**

**4.Ruota
anteriore**



Telaio di funzionamento



1-1



1-2

* Aprire la scatola, prendere il telaio e tutte le parti dalla busta, tirare la maniglia verso l'alto come nell'immagine 1-1.

* Continuare a tirare la maniglia verso l'alto fino al clic sonoro.

ASSEMBLARE LA BORSA PER ANIMALI DOMESTICI



2-1



2-2



2-3

* Aprire due cavi di supporto come in figura 2-1.

* Far passare le cinture di sicurezza attraverso i fori, quindi fissare il velcro come in figura 2-2.

* Chiudere la cappottina con la cerniera lampo come in figura 2-3.

Assemblare le ruote anteriori

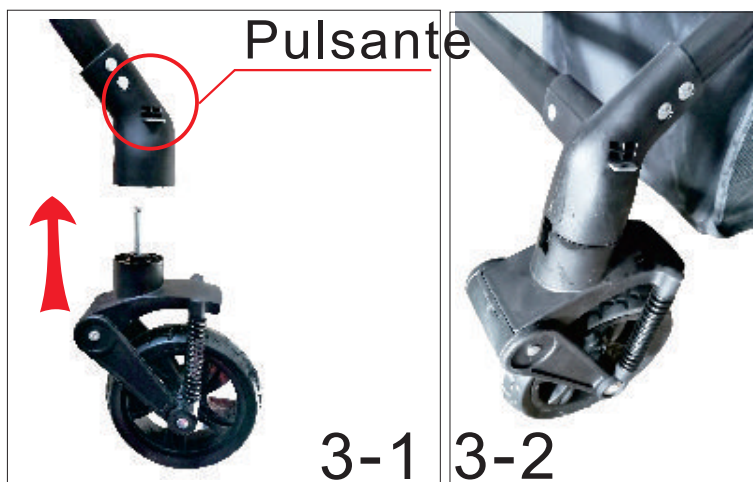

* Mettere le ruote anteriori: spingere le ruote anteriori sul telaio fino a quando non si sente un clic, come nella figura 3-1.

* Rimuovere le ruote anteriori: premere il pulsante come nell'immagine 3-1, mentre si tira su il passeggino con un'altra mano come nell'immagine 3-2.

Assemblare ruote vere e proprie

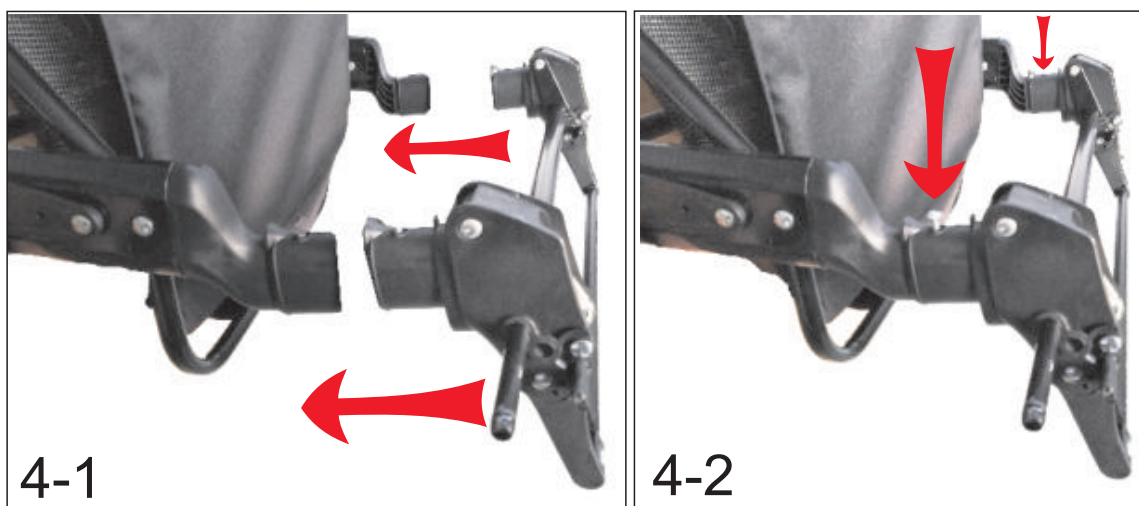

* Installare il supporto della ruota posteriore e bloccare le viti.

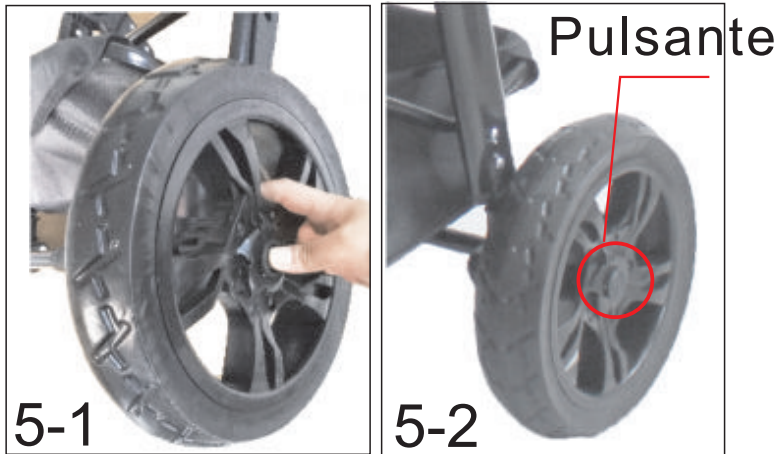

* Premendo il pulsante al centro delle ruote, inserire l'asse.
 Aprire la parte in rete.



*Aprire e chiudere la parte di rete tramite la cerniera come nell'immagine 6.

Freno



* Freno delle ruote posteriori: abbassare l'asta del freno per parcheggiare il passeggino; tirare l'asta del freno verso l'alto per sbloccarlo.

Installare la gabbia per animali domestici

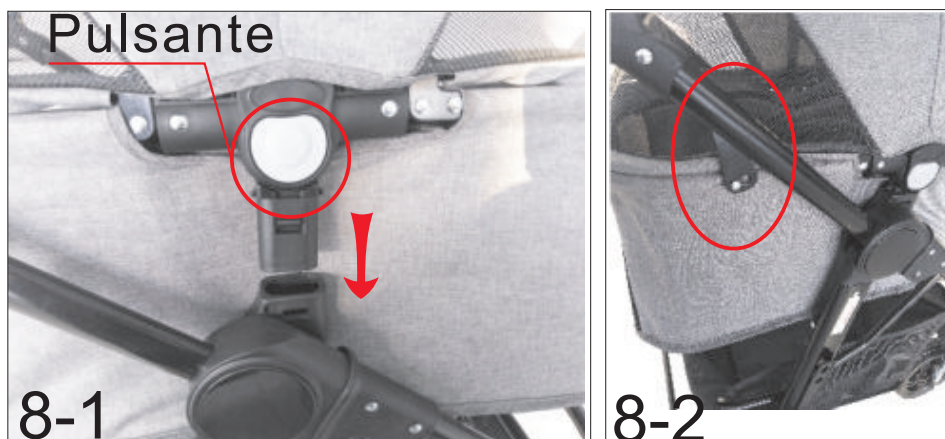

* Installare la gabbia per animali: Tenere la gabbia per animali domestici con entrambe le mani e inserire il connettore nella presa fino a quando non si sente un "clic" come nell'immagine 8-1. Quindi installare il gancio di fissaggio.

Prodotto pieghevole



*Ruotare la barra pieghevole come mostrato in figura, tirare contemporaneamente i connettori su entrambi i lati del passeggino e premere la maniglia.

Cintura di sicurezza

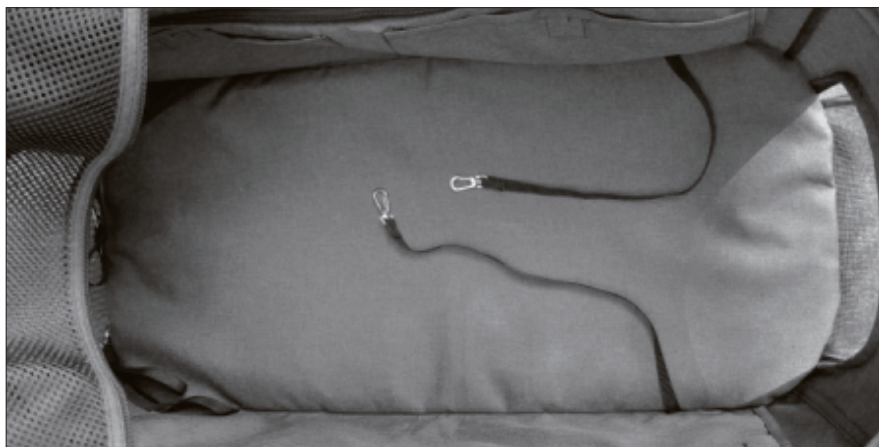

*Si prega di utilizzare la cintura di sicurezza quando l'animale è nella culla.

Maniglia di regolazione

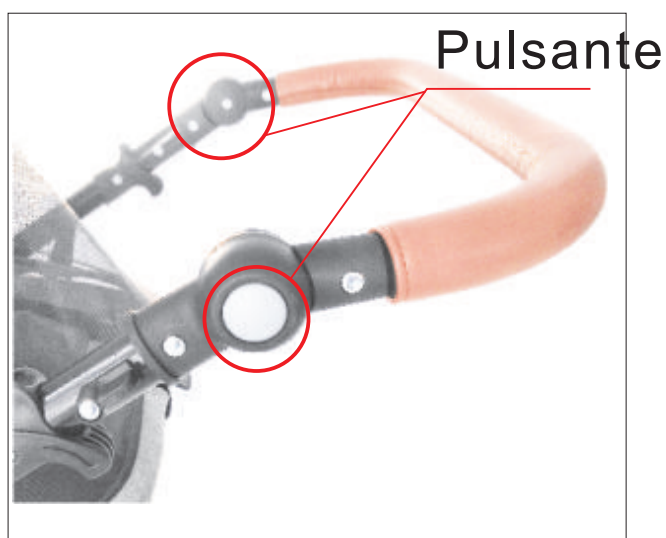

* Premere i pulsanti su entrambi i lati dell'impugnatura, quindi regolare

ATTENZIONE:

1. Solo per animali domestici.
2. Non lasciare l'animale nel passeggino incustodito.
3. Azionare sempre il freno quando il passeggino è fermo.
4. La capacità massima di peso è di 25 kg.
5. Non utilizzare componenti non forniti dal produttore.

Pulizia e manutenzione:

1. Sganciare il pulsante del passeggino;
2. Smontare la capottina;
3. Estrarre il cuscino;
4. Pulire leggermente il passeggino.