



IN230300120V02_UK

370-276V00



CHILDREN'S Pedal GO KART



Assembly video please scan the QR code.



The chain maintain video please scan the QR code.

WARNING: Certification Age:5+ years old; Max weight: 50 kg.

IMPORTANT, RETAIN FOR FUTURE REFERENCE: READ CAREFULLY

ASSEMBLY INSTRUCTION

A x 1



B x 1



C x 1



D x 1



E x 1



F x 4



G x 1



H x 1



I x 4



J x 2

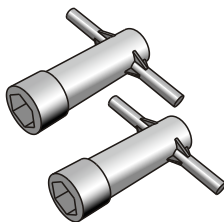

K x 1

**Note:**

All screws, nuts and small plastic parts are pre-installed in the corresponding position, please follow the steps to remove before you install the product.

- Assembly tools required:



Screwdriver wrench
(not included)

⚠ WARNING:

1. CHOKING HAZARD—Small parts. Not for children under 3 years.
2. Only allowed for adults to install, keep children away.
3. To be used under the direct supervision of an adult.
4. Just only allow one child to use.
5. Please use on a flat and clean surface. Never use near steps, sloped driveways, hills roadways, alleys, swimming pool areas, road, on grass or wet surfaces or other bodies of water.
6. Before driving toy car each time, adult should inspect screws of every parts, please tighten the screw cap if any looseness. secure all fasteners before every ride.
7. Always wear shoes and suitable protective equipment. always wear a local standard approved helmet while riding, with the chinstrap securely fastened.
8. Do not ride the product at dusk, at night or at times of limited visibility.
9. Always comply with local laws and regulations.

MAINTENANCE & CARE

- A. Keep all instructions and parts relating to this product for future reference.
- B. Regularly check for damage and that all screws are securely tightened.
- C. Check that the seat is securely fastened.
- D. Lubricate the chain as often as required.
- E. Regularly check tyre pressures.

1. Attach the Steering connection plate

Bottom view

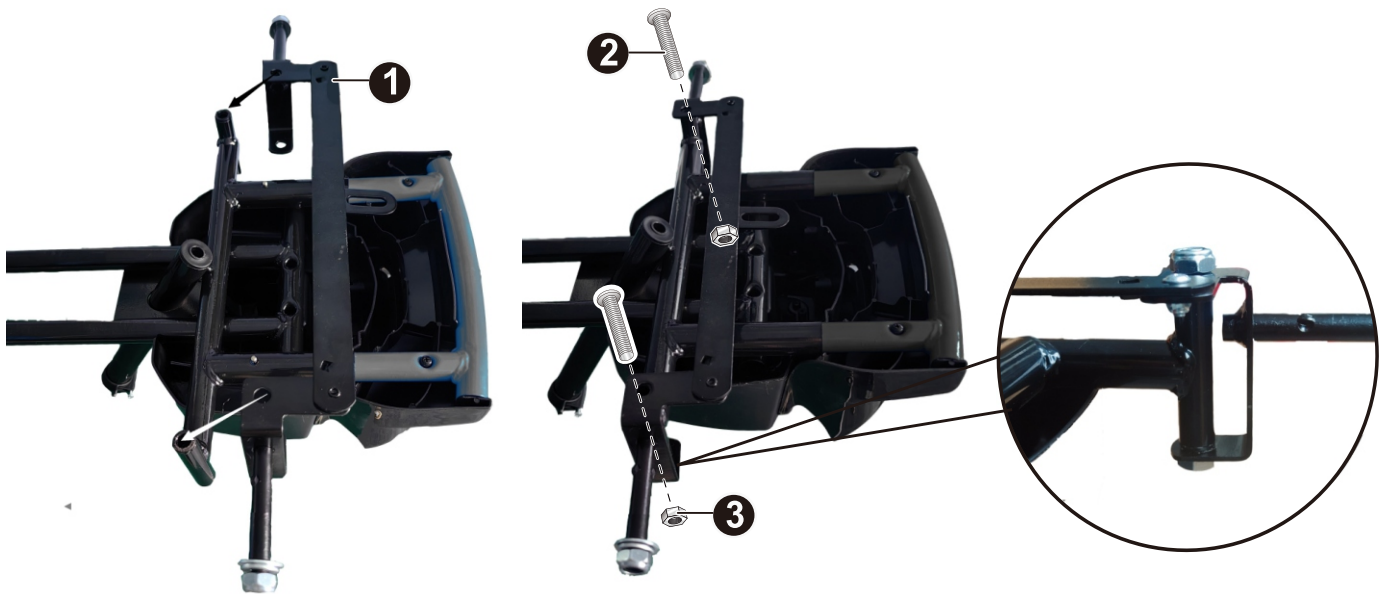

Cutting the cable ties and remove the steering bracket

1. Loosening M10*90mm screw then place the steering bracket on the body.
- 2-3. Screwing with the steering bracket with M10*90mm screw & M10 nut.

2. Attach the Rear Wheels

Rear right view



1. Slide the drive bracket into the rear axle.
- 2-3. attach the drive bracket to the rear axle using M5*25 screws and M5 nuts.
4. Slide the rear wheel into the rear axle so that it is connected to the drive bracket.
5. Slide a 10 washer onto the rear axle.
6. Tighten the lock M10 nut to the end of the rear axle using a wrench.

Rear left view



7. Slide the rear wheel into the rear axle .
8. Slide a 10 washer onto the rear axle.
9. Tighten the lock M10 nut to the end of the rear axle using a wrench.

3. Attach the Front Wheels & Steering Axle



1. Slide a 12 washer onto the front axle.
2. Slide the wheel into the front axle.
3. Slide a 10 washer onto the front axle.
4. Tighten the lock M10 nut to the end of the front axle using a wrench.

Repeat for the other front wheel.

Turn the go cart on its side.

5. Put the 10 washer on the Steering Axle. (Don't remove the washer from the Steering Axle)
6. Insert the Steering Axle through the steering Axle Support, make sure the other hook to the opening hole on the Front Axle.

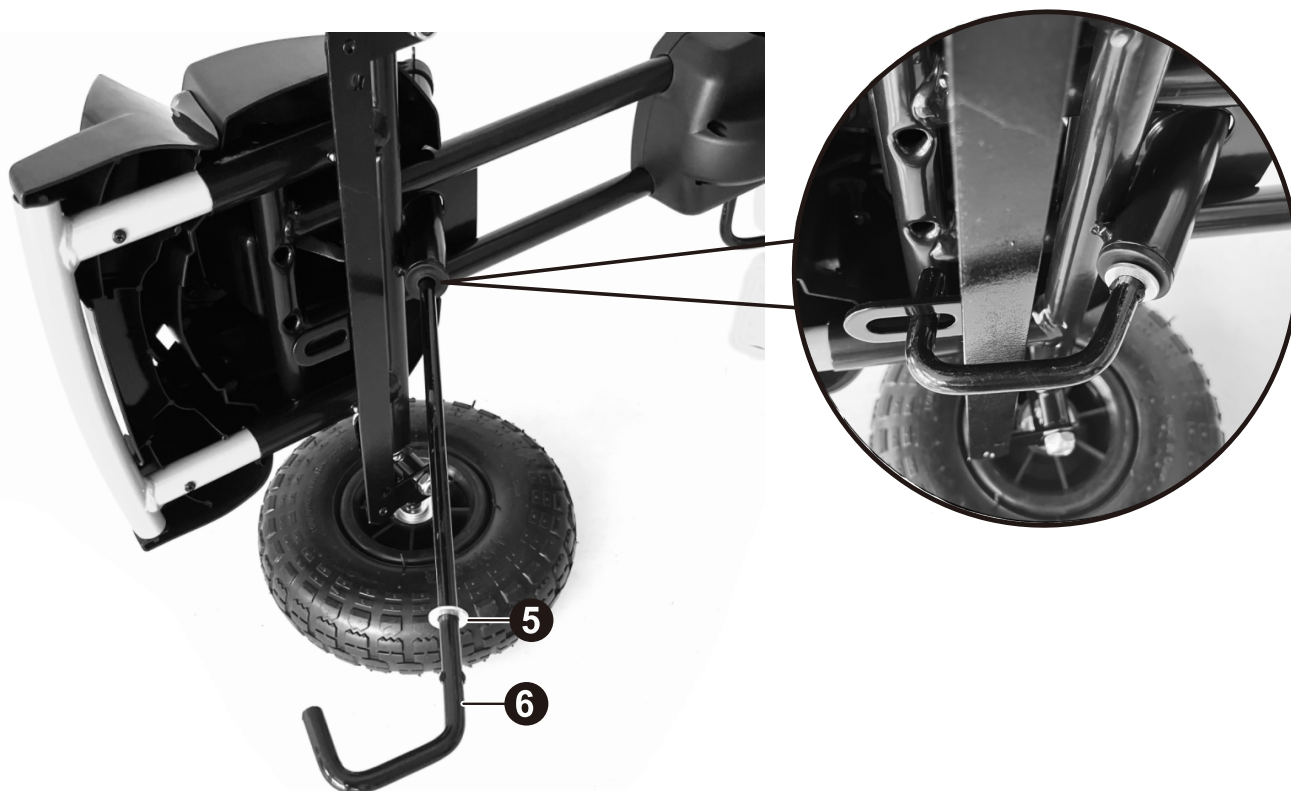

4. Attach the Steering Wheel & Front Cover

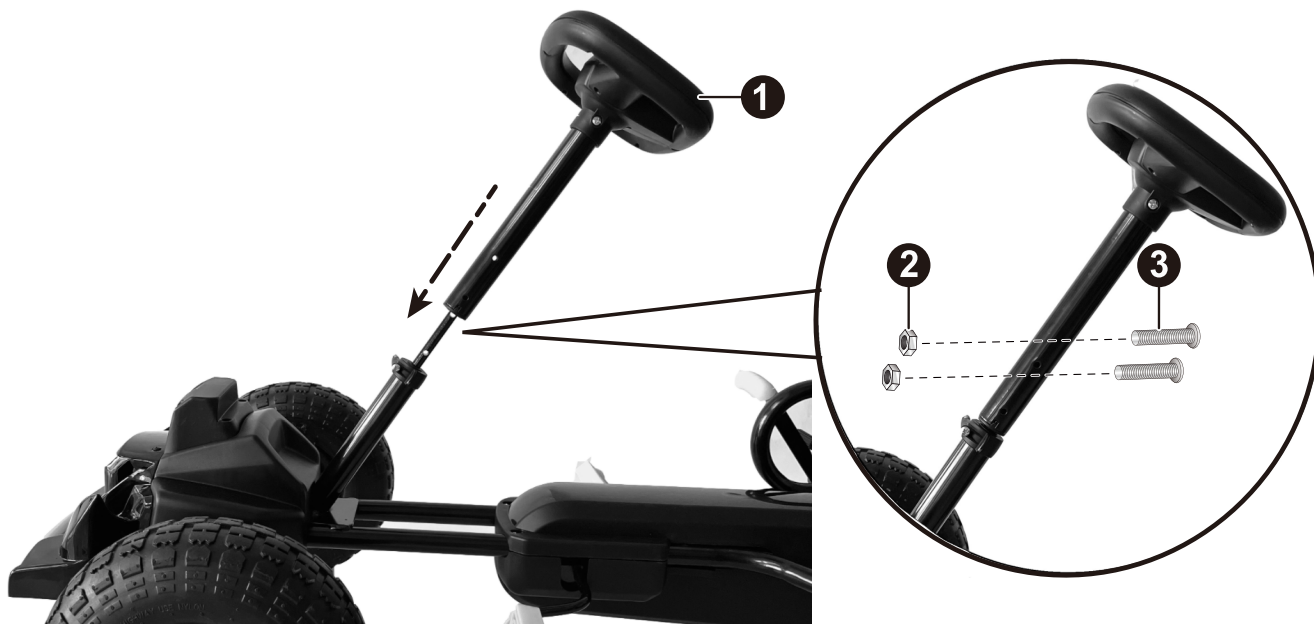

Remove M5*32 screw & M5 nut from the Steering Wheel.

1. Insert the Steering Wheel to the end of the Steering Axle, align the holes of the Steering Wheel and Steering Axle,

2-3. Secure with M5*32 screw & M5 nut the Steering Wheel.

Remove M4*14 screw from the body.

4. Align the Front Cover and Body and insert bottom into the body opening slot,

5. Secure with M4*14 screw the Front Cover.



5. Attach the Seat



Remove M5*55mm & M5 nut from the Body.

- 1.Align and assemble the Seat to the Body
- 2-3.Secure with M5*55mm & M5 nut the Seat.

6. Attach the fender



Remove the M5*10 screws from the rack.
1.Place the clay tablets on the frame and align them with the holes.

2.Use the M5*10 screw to secure it.

There are four clay tablets. Please install them one by one.

Use your New bicycle



1. **Brake:** Press to slow or brake down the vehicle.
2. **Pedals:** To move the vehicle forward and reverse.
3. **Steering wheel:** Controls the direction of the vehicle.

Chain Adjustment

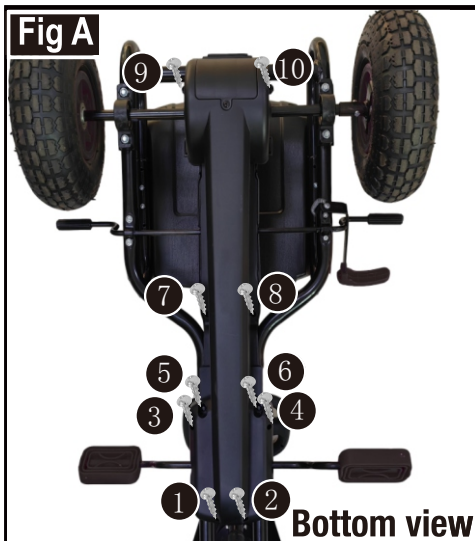

Bottom view

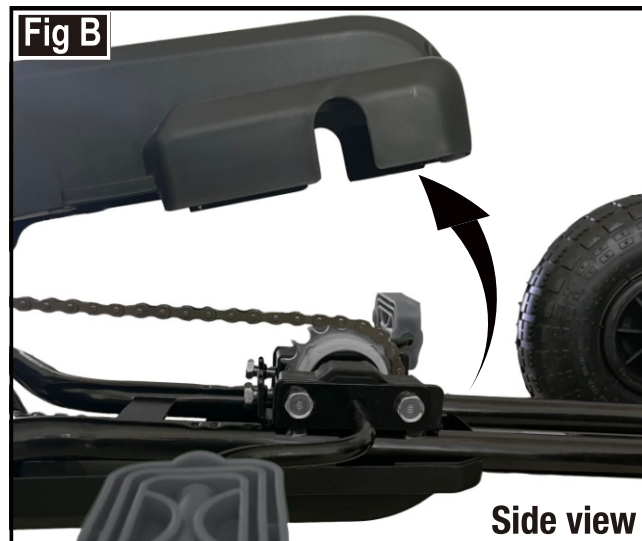

Side view

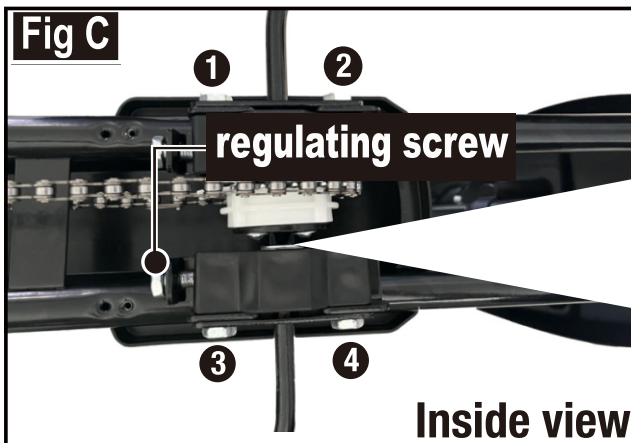

Inside view

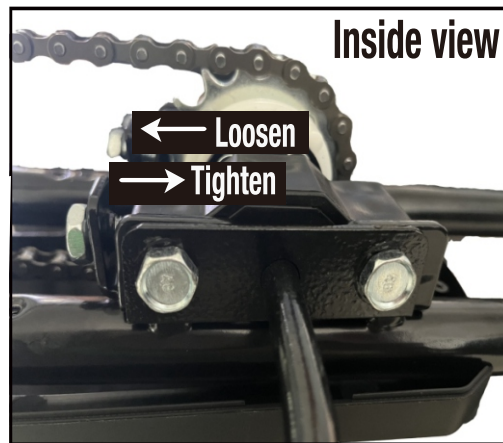

Inside view

The chain must be at the correct tightness. If too tight, the bicycle will be difficult to pedal. If too loose, the chain can come off the sprockets.

Adjust the tightness of the chain as follows:

- A. Turn the product downside up. Remove the six screws on the bottom of the product with a screwdriver.
- B. Press the two buckles on the side of the product, Lift up the chain cover.
- C. Loosen the four fixed screws and adjust the screws according to the tightness of the chain.



KART A PÉDALES POUR ENFANTS



Vidéo d'assemblage,
veuillez scanner le code
QR.



La vidéo du maintien de
la chaîne, veuillez
scanner le code QR.

ATTENTION: Âge de certification: 5+ ans; Poids maximum : 50 kg.

**IMPORTANT: A LIRE ATTENTIVEMENT ET À CONSERVER POUR
CONSULTATION ULTÉRIEURE.**

Assemblage & manuel d'instructions

A x 1



B x 1



C x 1



D x 1



E x 1



F x 4



G x 1



H x 1



I x 4



J x 2

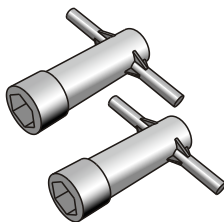

K x 1

**Note:**

Toutes les vis, écrous et petites pièces en plastique sont préinstallés dans la position correspondante, veuillez suivre les étapes à retirer avant d'installer le produit.

- Outils d'assemblage



Clé pour tournevis
(Non inclus)

⚠ AVERTISSEMENT :

1. DANGER D'ÉTOUFFEMENT - Petites pièces. Pas conseillé aux enfants de moins de 3 ans.
2. Installation par des adultes uniquement, tenir les enfants à l'écart.
3. À utiliser sous la surveillance directe d'un adulte.
4. Ne doit être utilisé que par un seul enfant à la fois.
5. À utiliser sur une surface plane et propre. Ne jamais utiliser à proximité d'un escalier, d'une entrée en pente, d'une route en pente, d'une allée, d'une piscine, d'une route, sur l'herbe ou sur des surfaces mouillées ou d'autres plans d'eau.
6. Avant de conduire à chaque fois le jouet, l'adulte doit inspecter les vis de chaque pièce, veuillez serrer le bouchon à vis s'il est desserré. Fixez toutes les attaches avant chaque trajet.
7. Portez toujours des chaussures et un équipement de protection approprié. Portez toujours un casque homologué selon les normes locales pendant que vous roulez, avec la jugulaire solidement attachée.
8. Ne pas rouler au crépuscule, la nuit ou à des heures de visibilité réduite.
9. Respectez toujours les lois et règlements locaux.

ENTRETIEN ET MAINTENANCE

- A. Conservez toutes les instructions et les pièces relatives à ce produit pour pouvoir vous y référer ultérieurement.
- B. Vérifiez régulièrement que le produit n'est pas endommagé et que toutes les vis sont bien serrées.
- C. Vérifier que le siège est bien fixé.
- D. Lubrifiez la chaîne aussi souvent que nécessaire.
- E. Vérifiez régulièrement la pression des pneus.

1. Fixation de la plaque de raccordement de direction

Vue du bas

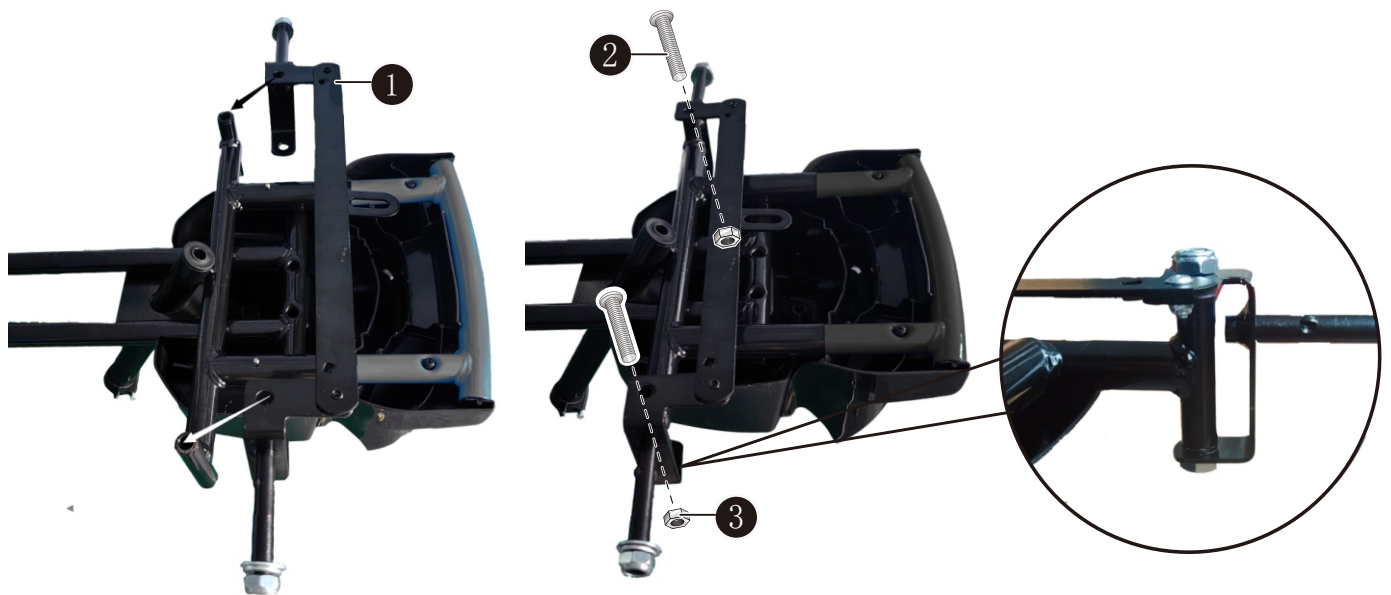

Découpage des serre-câbles et démontage du support de direction

1. Desserrer la vis M10*90mm puis monter le support de direction sur la carrosserie.
- 2-3. Visser le support de direction avec la vis M10*90mm et l'écrou M10.

2. Fixation des roues arrière

Vue arrière droite



1. Faites glisser le support d'entraînement dans l'essieu arrière.
- 2-3. fixez le support d'entraînement à l'essieu arrière à l'aide de vis M5 * 25 et d'écrous M5.
4. Faites glisser la roue arrière dans l'essieu arrière afin qu'elle soit reliée au support d'entraînement.
5. Faites glisser une rondelle 10 sur l'essieu arrière.
6. Serrez l'écrou de verrouillage M10 à l'extrémité de l'essieu arrière à l'aide d'une clé.

Vue arrière gauche



7. Faites glisser la roue arrière dans l'essieu arrière.
8. Faites glisser une laveuse 10 sur l'essieu arrière.
9. Serrez le contre-écrou M10 à l'extrémité de l'essieu arrière à l'aide d'une clé.

3. Fixation des roues avant et de L'essieu directeur



1. Faites glisser une rondelle 12 sur l'essieu avant.
2. Faites glisser la roue dans l'essieu avant.
3. Faites glisser une rondelle 10 sur l'essieu avant.
4. Serrez l'écrou de verrouillage M10 à l'extrémité de l'essieu avant à l'aide d'une clé.

Répétez l'opération pour l'autre roue avant.

Tournez le kart sur le côté.

5. Mettez la rondelle 10 sur l'essieu directeur. (Ne retirez pas la rondelle de l'essieu directeur)
6. Insérez l'essieu directeur à travers le support de l'essieu directeur, assurez-vous que l'autre crochet au trou d'ouverture sur l'essieu avant.

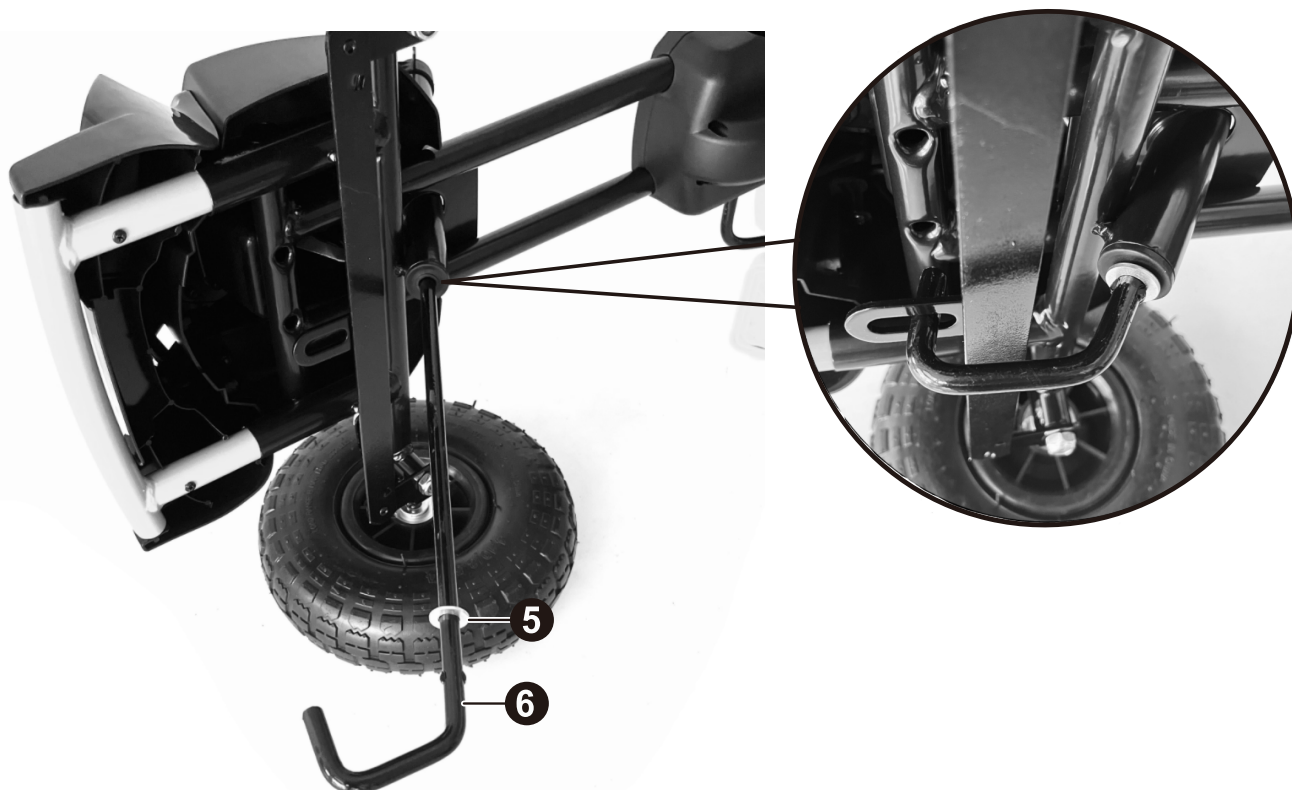

4. Fixation du volant et du capot avant

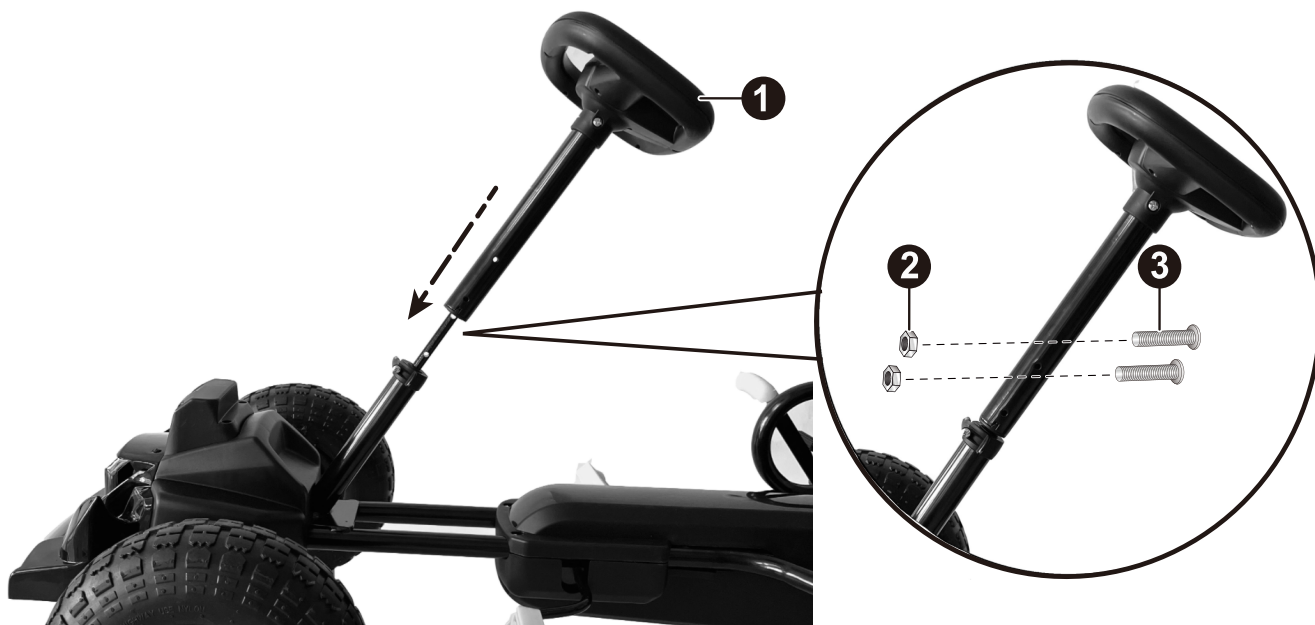

Retirez la vis M5 * 32 et l'écrou M5 du volant.

1. Insérez le volant à l'extrémité de l'essieu directeur, alignez les trous du volant et de l'essieu directeur,

2-3. Fixez le volant avec la vis M5 * 32 et écrou M5.

Retirez la vis M4 * 14 de la carrosserie.

4. Alignez le capot avant et la carrosserie, et insérez le bas dans la fente d'ouverture du corps,

5. Fixez le capot avant avec la vis M4 * 14 .



5. Fixation du siège



Retirez l'écrou M5 * 55mm et M5 de la carrosserie.

1. Alignez et assemblez le siège à la carrosserie
- 2-3. Fixez le siège avec l'écrou M5*55mm et M5.

6. Fixation du garde-boue



Retirez les vis M5*10 du support.

1. Placez les tablettes d'argile sur le cadre et alignez -les avec les trous.
2. Fixez-les à l'aide de la vis M5*10. Il y a quatre tablettes d'argile. Veuillez les installer une par une.

Utilisation de votre nouveau kart



1. **Frein:** appuyez pour ralentir ou freiner le véhicule.
2. **Pédales:** pour faire avancer et reculer le véhicule.
3. **Volant:** Contrôle la direction du véhicule.

Ajustement de la chaîne

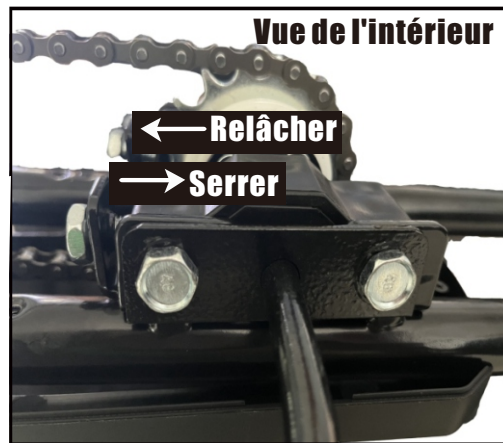
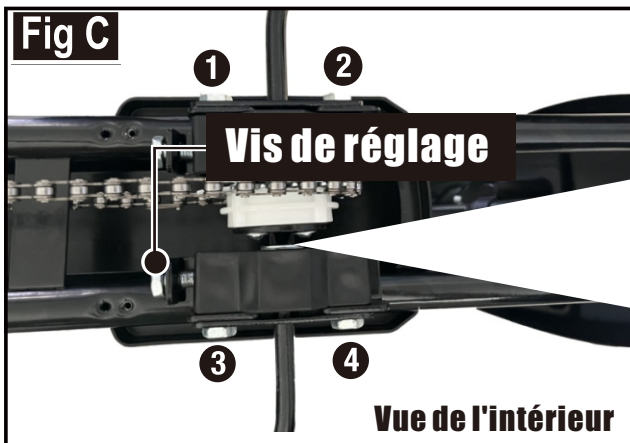
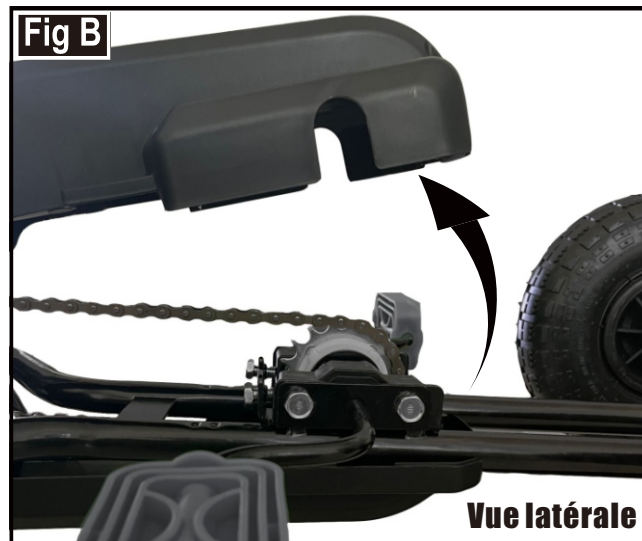
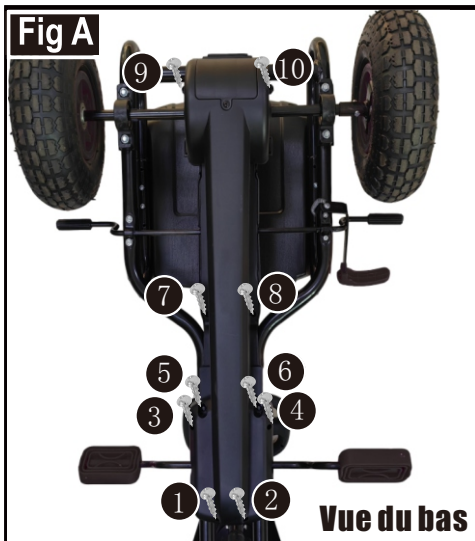

La chaîne doit être à la bonne étanchéité. Si elle est trop serrée, il sera difficile de pédaler. Si elle est trop desserrée, la chaîne peut se détacher des pignons.

Régler le serrage de la chaîne comme suit :

- A. Retournez le produit à l'envers. Retirez les six vis situées au bas du produit à l'aide d'un tournevis.
- B. Appuyez sur les deux boucles sur le côté du produit, soulevez le couvercle de la chaîne.
- C. Desserrez les quatre vis fixes et ajustez les vis en fonction du serrage de la chaîne.



KINDER Pedal-GO-KART



Montagevideo scannen Sie bitte den QR-Code ein.



Das Video zur Kettenpflege scannen Sie bitte den QR-Code.

WARNUNG: Zertifizierungsalter: 5+ Jahre; Max. Gewicht: 50 kg.

WICHTIG! SORGFÄLTIG LESEN UND FÜR SPÄTER NACHSCHLAGEN AUFBEWAHREN.

MONTAGEANWEISUNGEN

A x 1



B x 1



C x 1



D x 1



E x 1



F x 4



G x 1



H x 1



I x 4



J x 2

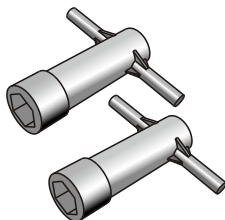

K x 1

**Hinweis:**

Alle Schrauben, Muttern und kleinen Kunststoffteile sind an der entsprechenden Position vorinstalliert. Bitte folgen Sie den folgenden Schritten, bevor Sie das Produkt installieren.

- Erforderliches Werkzeug für den Zusammenbau:



Schraubenzieher-Schlüssel
(nicht mitgeliefert)

! WARNUNG:

1. ERSTICKUNGSGEFAHR-Kleine Teile. Nicht für Kinder unter 3 Jahren geeignet.
2. Die Montage darf nur von Erwachsenen vorgenommen werden, halten Sie Kinder fern.
3. Es ist unter der direkten Aufsicht eines Erwachsenen zu verwenden.
4. Erlauben Sie jeweils nur einem Kind es zu benutzen.
5. Verwenden Sie es bitte auf einer ebenen und sauberen Oberfläche. Es sollte niemals in der Nähe von Treppen, steile Auf-/ oder Abfahrten, hügeligen Straßen, Alleen, Schwimmbadbereichen, Straßen, auf Gras oder nassen Oberflächen oder anderen Gewässern benutzt werden.
6. Vor jeder Nutzung des Spielzeugautos sollte ein Erwachsener die Schrauben aller Teile überprüfen. Ziehen Sie bitte die Schraubenkappen fest, wenn sie locker sind. Überprüfen Sie vor jeder Fahrt alle Befestigungselemente.
7. Es sollten immer Schuhe und eine geeignete Schutzausrüstung getragen werden. Während der Fahrt sollte immer ein gemäß der örtlichen Norm zugelassener Helm getragen werden, dessen Kinnriemen fest sitzt.
8. Nicht während der Dämmerung, bei Nacht oder bei eingeschränkter Sicht mit dem Produkt fahren.
9. Beachten Sie stets die örtlichen Gesetze und Vorschriften.

WARTUNG & PFLEGE

- A. Bewahren Sie alle Anweisungen und Teile, die sich auf dieses Produkt beziehen, zur späteren Verwendung auf.
- B. Prüfen Sie es regelmäßig auf Beschädigungen und ob alle Schrauben fest angezogen sind.
- C. Prüfen Sie, ob der Sitz sicher befestigt ist.
- D. Schmieren Sie die Kette so oft wie nötig.
- E. Prüfen Sie regelmäßig den Reifendruck.

1. Befestigen Sie die Anschlussplatte für die Lenkung

Ansicht von unten



Schneiden Sie die Kabelbinder durch und entfernen Sie die Lenkungshalterung

1. Lösen Sie die M10 × 90 mm Schraube und setzen Sie die Lenkungshalterung auf die Karosserie.
- 2-3. Verschrauben Sie die Lenkungshalterung mit einer M10 × 90 mm Schraube und einer M10 Mutter.

2. Befestigen Sie die Hinterräder

Ansicht von hinten rechts

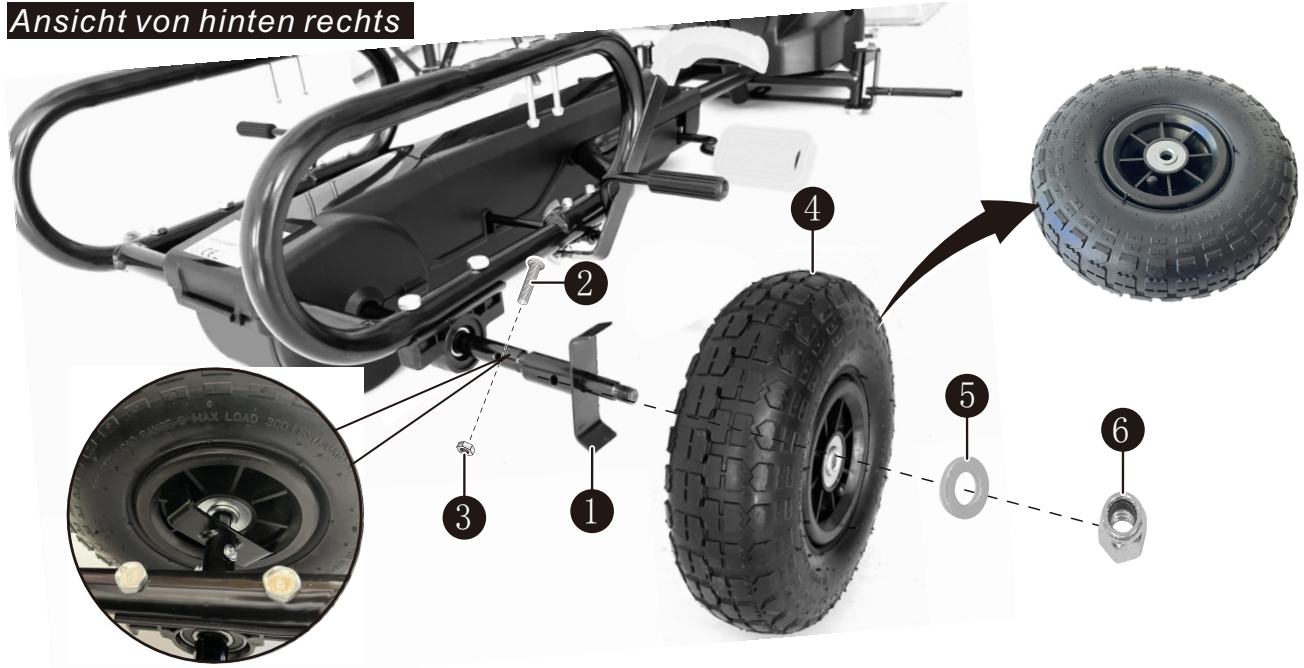

1. Schieben Sie die Antriebshalterung in die Hinterachse.
- 2-3, befestigen Sie die Antriebshalterung mit M5 x 25 Schrauben und M5 Muttern an der Hinterachse.
4. Schieben Sie das Hinterrad so in die Hinterachse, dass es mit der Antriebshalterung verbunden ist.
5. Schieben Sie eine 10er Unterlegscheibe auf die Hinterachse.
6. Ziehen Sie die Kontermutter M10 am Ende der Hinterachse unter Verwendung eines Schraubenschlüssels fest.

Ansicht hinten links



7. Schieben Sie das Hinterrad in die Hinterachse.
8. Schieben Sie eine 10er Unterlegscheibe auf die Hinterachse.
9. Ziehen Sie die Kontermutter M10 am Ende der Hinterachse unter Verwendung eines Schraubenschlüssels fest.

3. Befestigen Sie die Vorderräder und die Lenkachse



1. Schieben Sie eine 12er Unterlegscheibe auf die Vorderachse.
2. Schieben Sie das Rad in die Vorderachse.
3. Schieben Sie eine 10er Unterlegscheibe auf die Vorderachse.
4. Ziehen Sie die Kontermutter M10 am Ende der Vorderachse unter Verwendung eines Schraubenschlüssels fest.

Wiederholen Sie den Vorgang für das andere Vorderrad.

Drehen Sie den Go-Cart auf die Seite.

5. Setzen Sie die 10er Unterlegscheibe auf die Lenkachse. (Entfernen Sie die Unterlegscheibe nicht von der Lenkachse)
6. Stecken Sie die Lenkachse durch die Lenkachsenhalterung und stellen Sie sicher, dass der andere Haken in der Öffnung an der Vorderachse fest sitzt.

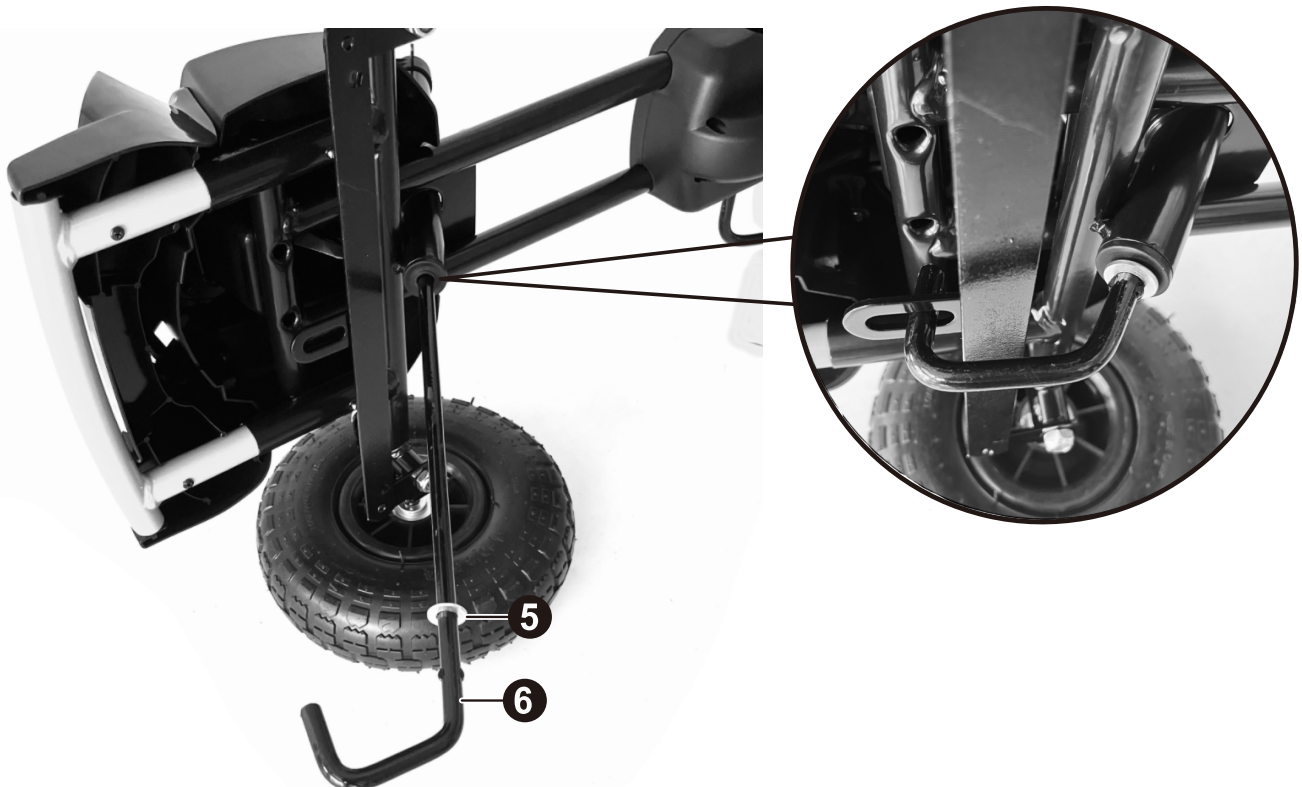

4. Befestigen Sie das Lenkrad und die vordere Abdeckung

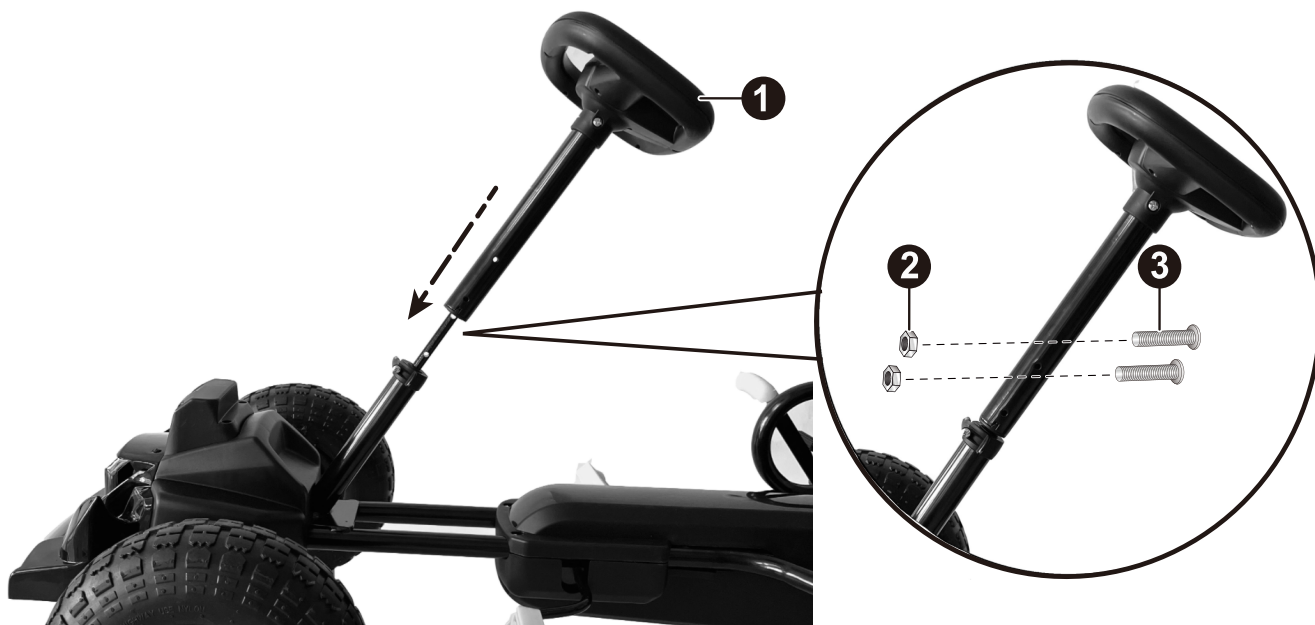

Entfernen Sie die M5 x 32 Schraube und die M5 Mutter vom Lenkrad.

1. Setzen Sie das Lenkrad in das Ende der Lenkachse ein, richten Sie die Löcher des Lenkrads und der Lenkachse aus,

2-3. Sichern Sie das Lenkrad mit der M5 x 32 Schraube und der M5 Mutter.

Entfernen Sie die M4 x 14 Schraube aus der Karosserie.

4. Richten Sie die vordere Abdeckung und die Karosserie aus und stecken Sie den Boden in den Steckplatz der Karosserieöffnung,

5. Sichern Sie die vordere Abdeckung mit der M4 x 14 Schraube.



5. Befestigen Sie den Sitz



Entfernen Sie die M5 x 55 mm und M5 Mutter von der Karosserie.

1. Richten Sie den Sitz aus und montieren Sie ihn an der Karosserie

2-3. Befestigen Sie den Sitz sicher mit der M5 x 55 mm und der M5-Mutter.

6. Befestigen Sie den Kotflügel



Entfernen Sie die M5 x 10 Schrauben vom Gestell.

1. Legen Sie die Tontafeln auf den Rahmen und richten Sie sie an den Löchern aus.

2. Verwenden Sie die M5 x 10 Schraube, um sie sicher zu befestigen. Es gibt vier Tontafeln. Bitte installieren Sie sie nacheinander.

Verwenden Sie Ihr neues Fahrzeug



1. **Bremse:** Drücken Sie, um das Fahrzeug zu verlangsamen oder abzubremsen.
2. **Pedale:** um das Fahrzeug vorwärts und rückwärts zu bewegen.
3. **Lenkrad:** Steuert die Richtung des Fahrzeugs.

Einstellen der Kette

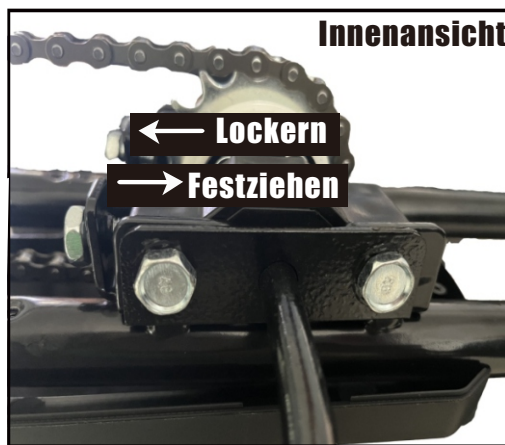
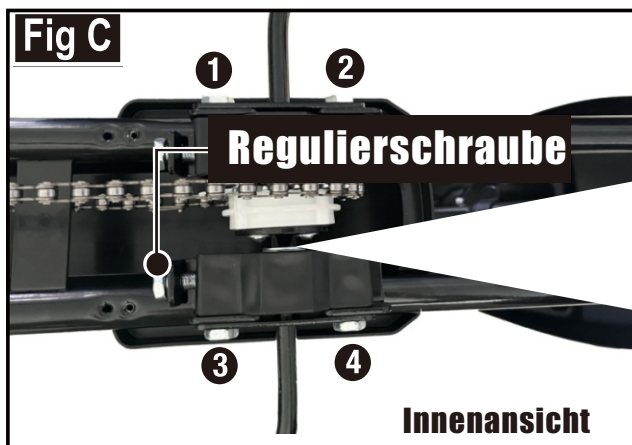
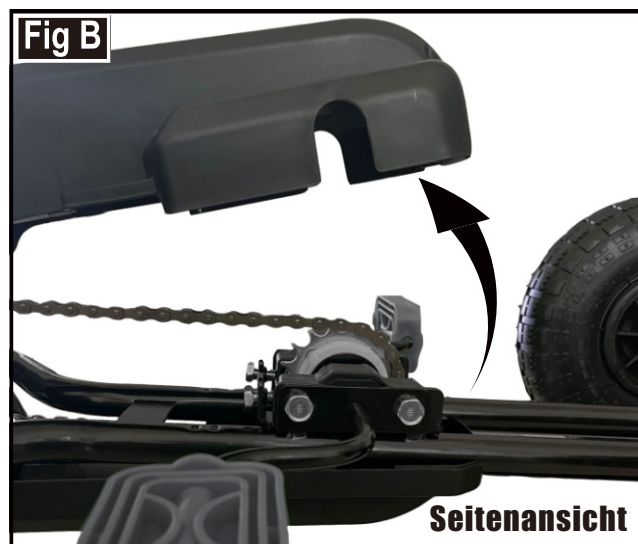
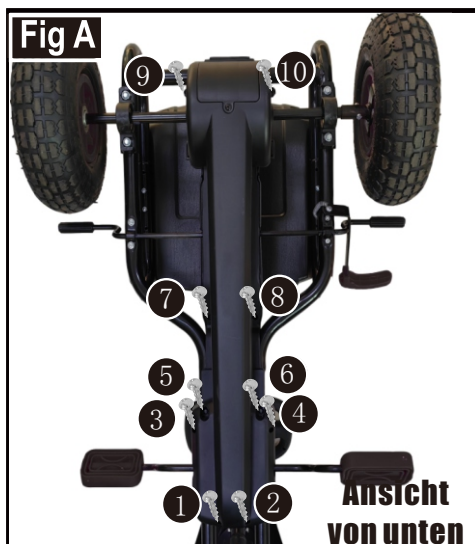

Die Kette muss richtig gespannt sein. Ist sie zu straff, lässt sich das Fahrzeug nur schwer treten. Ist sie zu locker, kann die Kette von den Ritzeln abspringen.

Stellen Sie die Spannung der Kette wie folgt ein:

- A. Drehen Sie das Produkt auf den Kopf. Entfernen Sie die sechs Schrauben an der Unterseite des Produkts mit einem Schraubenzieher.
- B. Drücken Sie auf die beiden Schnallen an der Seite des Produkts. Heben Sie die Abdeckung der Kette an.
- C. Lösen Sie die vier festen Schrauben und stellen Sie die Schrauben entsprechend der Straffheit der Kette ein.



KART INFANTIL A PEDALES



Vídeo de montaje,
escanea el código QR.



La cadena de mantener
el vídeo por favor
escanear el código QR.

ADVERTENCIA: Edad de certificación: 5+ años; Peso máximo: 50 kg.

IMPORTANTE, LEA Y GUARDE PARA FUTURAS REFERENCIAS.

INSTRUCCIONES DE MONTAJE

A x 1

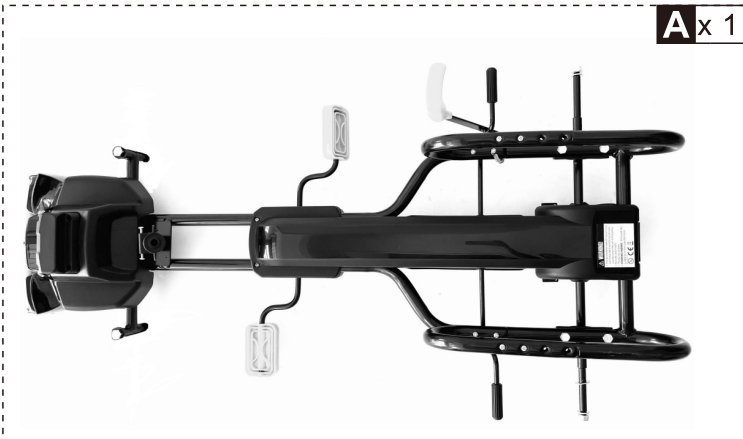

B x 1



C x 1



D x 1



E x 1

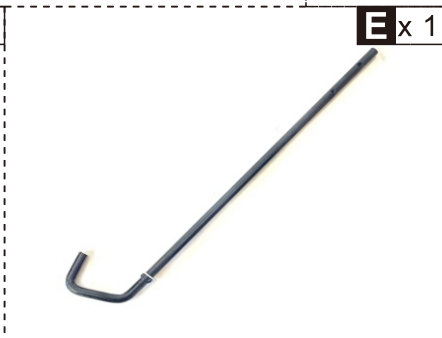

F x 4



G x 1



H x 1



I x 4



J x 2

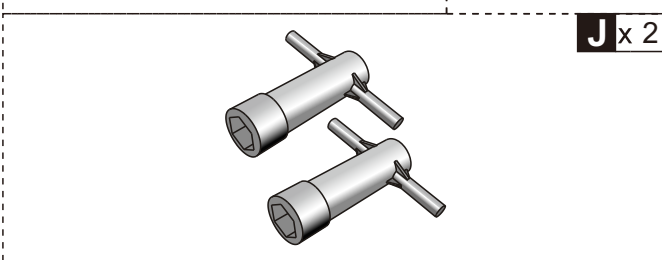

K x 1



Nota:

Todos los tornillos, tuercas y piezas pequeñas de plástico están pre instalados en la posición correspondiente, siga los pasos para retirarlos antes de montar el producto.

- Herramientas requeridas:

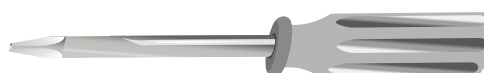

Destornillador llave inglesa
(no incluidas)

⚠️ ADVERTENCIA:

1. PELIGRO DE ASFIXIA: Incluidas piezas pequeñas. No es adecuado para los niños menores de 3 años.
2. La instalación sólo se puede realizar por los adultos, mantenga a los niños alejados al instalar el scooter.
3. El producto debe ser utilizado bajo la supervisión directa de un adulto.
4. Sólo se permita que un/una niño/a utilice este scooter a la vez.
5. Utilice este scooter sobre una superficie plana y limpia. Nunca lo utilice cerca de escalones, caminos de entrada inclinados, caminos de colinas, callejones, áreas de piscinas, carreteras, sobre césped o superficies mojadas u otros lugares cerca de cuerpos de agua.
6. Antes de conducir este scooter de juguete cada vez, el adulto debe inspeccionar los tornillos de cada pieza del scooter. Si la cubierta de rosca está floja, apriétela bien. Fije todos los sujetadores bien antes de cada uso.
7. Siempre lleve calzado y equipo de protección adecuado al conducir este scooter. Siempre use un casco aprobado por las normas locales al conducir, y fije la correa de la barbilla bien abrochada.
8. No utilice este scooter al anochecer, de noche o en momentos con visibilidad limitada.
9. Siempre cumpla con las leyes y regulaciones locales.

MANTENIMIENTO Y CUIDADO

- A. Guarde todas las instrucciones y piezas relativas juntas con este producto para las referencias futuras.
- B. Compruebe regularmente para asegurarse de que no haya daños y que todos los tornillos estén apretados firmemente.
- C. Compruebe que el asiento del scooter esté abrochado firmemente.
- D. Lubrique la cadena frecuentemente si sea necesario.
- E. Compruebe regularmente la presión de los neumáticos.

1. Fijar la placa de conexión de la dirección

vista inferior



Corte las bridas de los cables y retire la ménsula de dirección

1. Afloje el tornillo M10*90 mm, luego coloque la ménsula de dirección en el cuerpo.
- 2-3. Fije la ménsula de dirección con el tornillo M10*90mm y la tuerca M10.

2.Fijar las ruedas traseras

vista trasera derecha

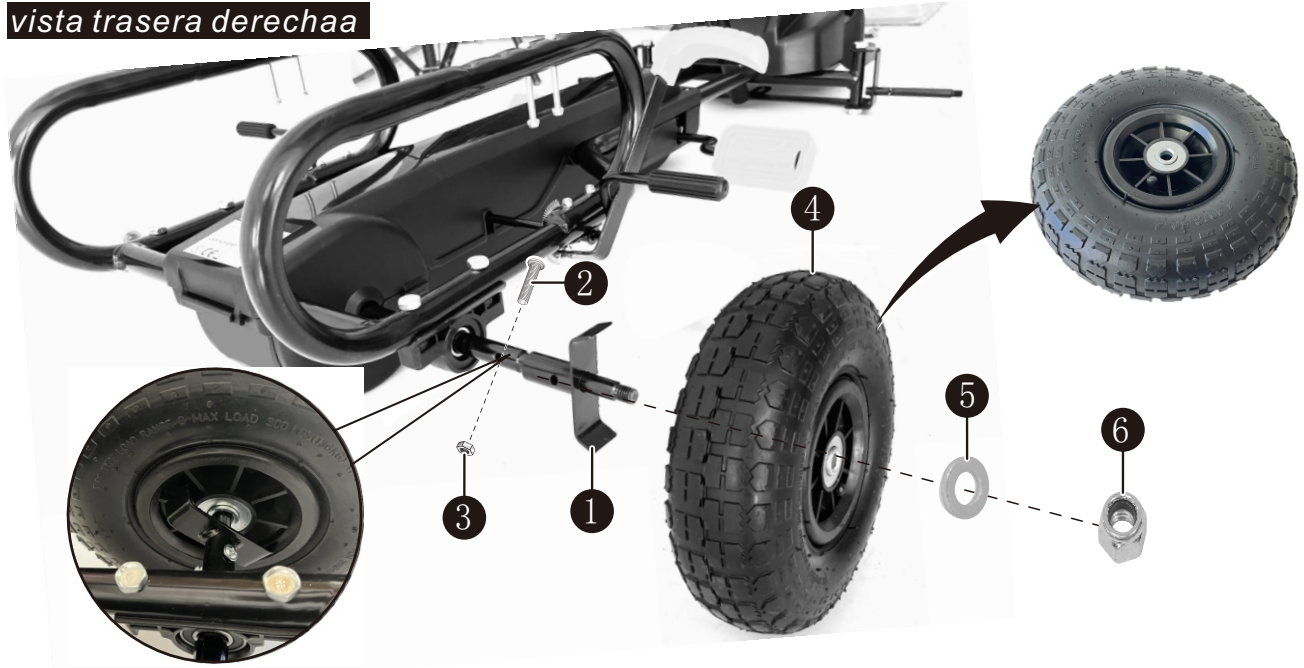

1. Deslice el soporte de accionamiento en el eje trasero.
- 2-3. Fije el soporte de accionamiento al eje trasero con tornillos M5*25 y tuercas M5.
4. Deslice la rueda trasera en el eje trasero para que quede conectada al soporte de accionamiento.
5. Deslice una arandela $\text{Ø}10$ en el eje trasero.
6. Apriete la tuerca de bloqueo M10 en el extremo del eje trasero con una llave.

vista trasera izquierda



7. Deslice la rueda trasera en el eje trasero .
8. Deslice una arandela 10 en el eje trasero.
9. Apriete la tuerca de bloqueo M10 en el extremo del eje trasero con una llave.

3. Fijar las ruedas delanteras y el eje de dirección



1. Deslice una arandela de $\varnothing 12$ en el eje delantero.
2. Deslice la rueda en el eje delantero.
3. Deslice una arandela de $\varnothing 10$ en el eje delantero.
4. Apriete la tuerca de seguridad M10 al final del eje delantero con una llave. Repita para la otra rueda delantera.

Gire el carrito de viaje de costado.

5. Coloque la arandela $\varnothing 10$ en el eje de dirección. (No quite la arandela del eje de dirección)
6. Inserte el eje de dirección a través del soporte del eje de dirección, asegúrese de que el otro gancho esté en el orificio de apertura del eje delantero.

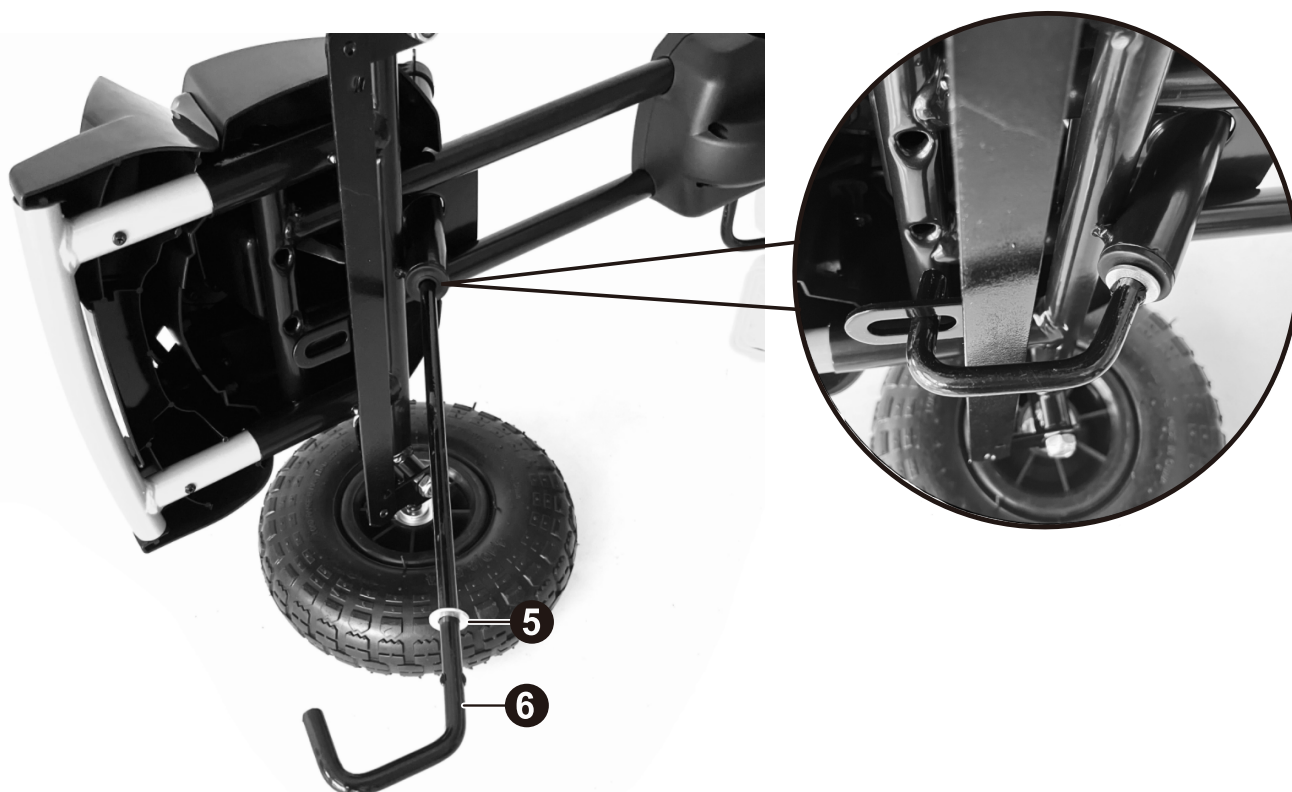

4. Colocar el volante y la cubierta frontal

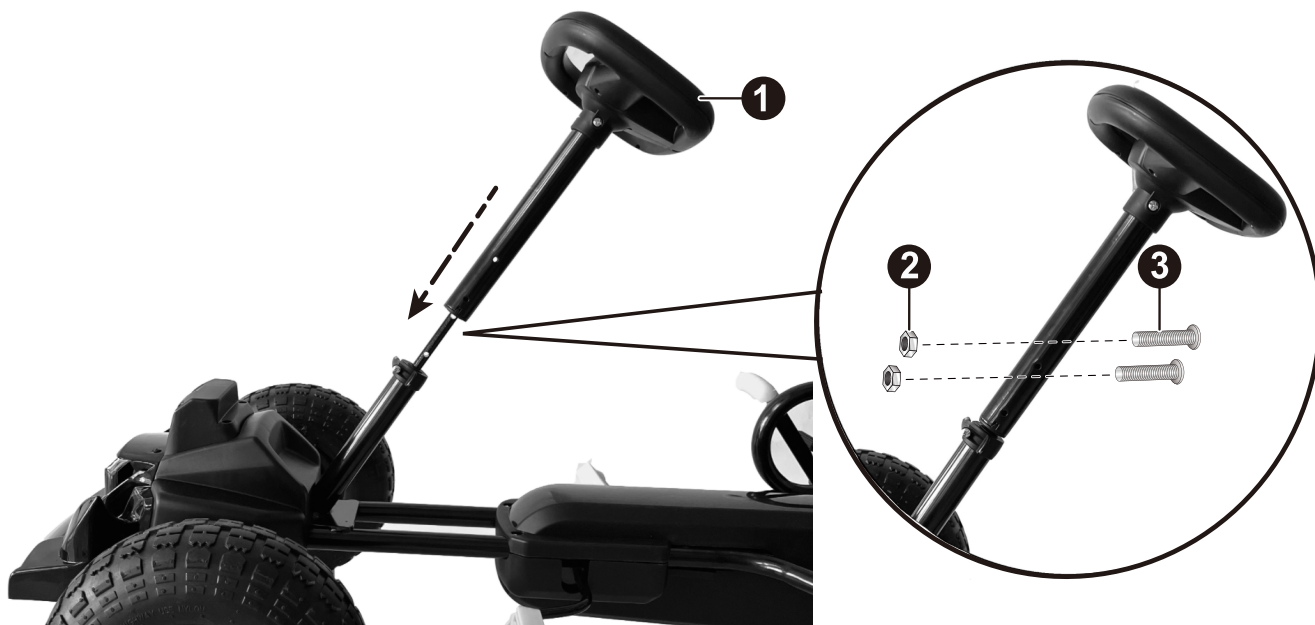

Retire el tornillo M5*32 y la tuerca M5 del volante.

1. Inserte el volante en el extremo del eje de dirección, alinee los agujeros del volante y del eje de dirección.

2-3. Asegure el volante con un tornillo M5*32 y una tuerca M5.

Retire el tornillo M4*14 de la carrocería.

4. Alinee la cubierta frontal y el cuerpo e inserte la parte inferior en la ranura de apertura del cuerpo.

5. Asegure con tornillos M4*14 la cubierta frontal.



5. Fijar el asiento



Quite la tuerca M5*55 mm y M5 del cuerpo.

1. Alinee y monte el asiento en el cuerpo.

2-3. Asegure el asiento con tuercas M5*55mm y M5.

6. Colocar el guardabarros



Retire los tornillos M5*10 del bastidor.

1. Coloque el guardabarros en el bastidor y alinéalo con los orificios.

2. Utilice el tornillo M5*10 para fijarlos. Hay cuatro guardabarros. Instálelos uno a uno.

Usar tu bicicleta nueva



1. **Freno:** Presione para reducir la velocidad o frenar el vehículo.
2. **Pedales:** Para mover el vehículo hacia adelante y hacia atrás.
3. **Volante:** Controla la dirección del vehículo.

Ajustar la cadena

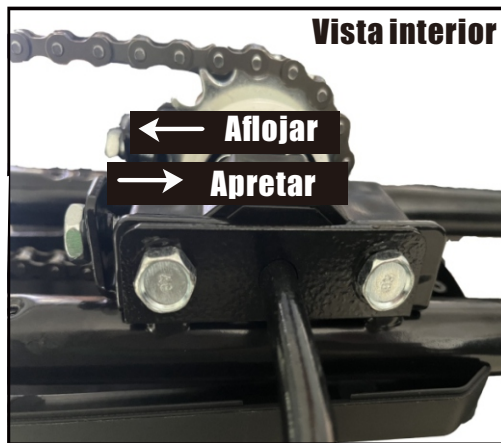
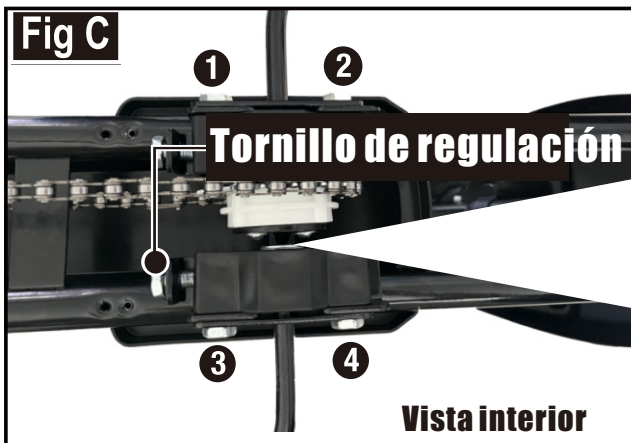

La cadena debe tener el apriete correcto. Si está demasiado apretada, la bicicleta será difícil de pedalear. Si está demasiado floja, la cadena puede salirse de los piñones.

Compruebe el apriete de la cadena de la siguiente manera:

- A. Gire el producto al revés. Retire los seis tornillos de la parte inferior del del producto con un destornillador.
- B. Presione las dos hebillas en el lado del producto, levante la cubierta de la cadena.
- C. Afloje los cuatro tornillos fijos y ajuste los tornillos de acuerdo con la tensión de la cadena.



KART INFANTIL



Vídeo de montagem,
escaneie o código QR.



A cadeia mantém o
vídeo por favor
digitalizar o código QR.

AVISO: Idade de certificação: 5+ anos; Peso máximo: 50 kg.

IMPORTANTE, RETER PARA REFERÊNCIA FUTURA: LEIA ATENTAMENTE

INSTRUÇÃO DE MONTAGEM

A x 1



B x 1



C x 1



D x 1



E x 1



F x 4



G x 1



H x 1



I x 4



J x 2

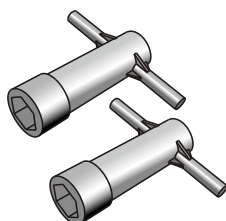

K x 1



Nota:

Todos os parafusos, porcas e pequenas peças de plástico são pré-instalados na posição correspondente, por favor siga os passos para remover antes de instalar o produto.

- Ferramentas de montagem necessárias:



Chave de fendas Chave inglesa
(não incluídas)

⚠️ ADVERTÊNCIA:

1. CHOKING HAZARD-Spequenas peças. Não para crianças com menos de 3 anos.
2. permitido apenas para adultos, manter as crianças afastadas.
3. A ser utilizado sob a supervisão directa de um adulto.
4. Só é permitida a utilização por uma única criança.
5. Por favor, utilizar sobre uma superfície plana e limpa. Nunca utilizar perto de degraus, caminhos inclinados, estradas de colinas, becos, áreas de piscinas, estrada, em relva ou superfícies molhadas ou outros corpos de água.
6. Antes de conduzir um carrinho de brinquedo de cada vez, os adultos devem inspeccionar os parafusos de cada peça, por favor aperte a tampa de rosca se houver alguma folga. fixe todos os parafusos antes de cada passeio.
7. usar sempre sapatos e equipamento de protecção adequado. usar sempre um capacete aprovado pela norma local durante a condução, com a correia do queixo firmemente apertada.
8. Não montar o produto ao anoitecer, durante a noite ou em alturas de visibilidade limitada.
9. Cumprir sempre as leis e regulamentos locais.

MANUTENÇÃO E CUIDADOS

- A. Guarde todas as instruções e partes relacionadas com este produto para referência futura.
- B. Verificar regularmente se há danos e se todos os parafusos estão bem apertados.
- C. Verificar se o assento está bem apertado.
- D. Lubrificar a corrente com a frequência necessária.
- E. Verificar regularmente a pressão dos pneus.

1. Fixar a Placa de Ligação da Direcção

Vista Inferior



Corte das abraçadeiras de cabo e remoção do suporte da direcção

1. soltar o parafuso M10*90mm e depois colocar o suporte de direcção na carroçaria.
- 2-3. Aparafusar com o suporte de direcção com parafuso M10*90mm e porca M10.

2. Fixar as Rodas

Vista posterior direita

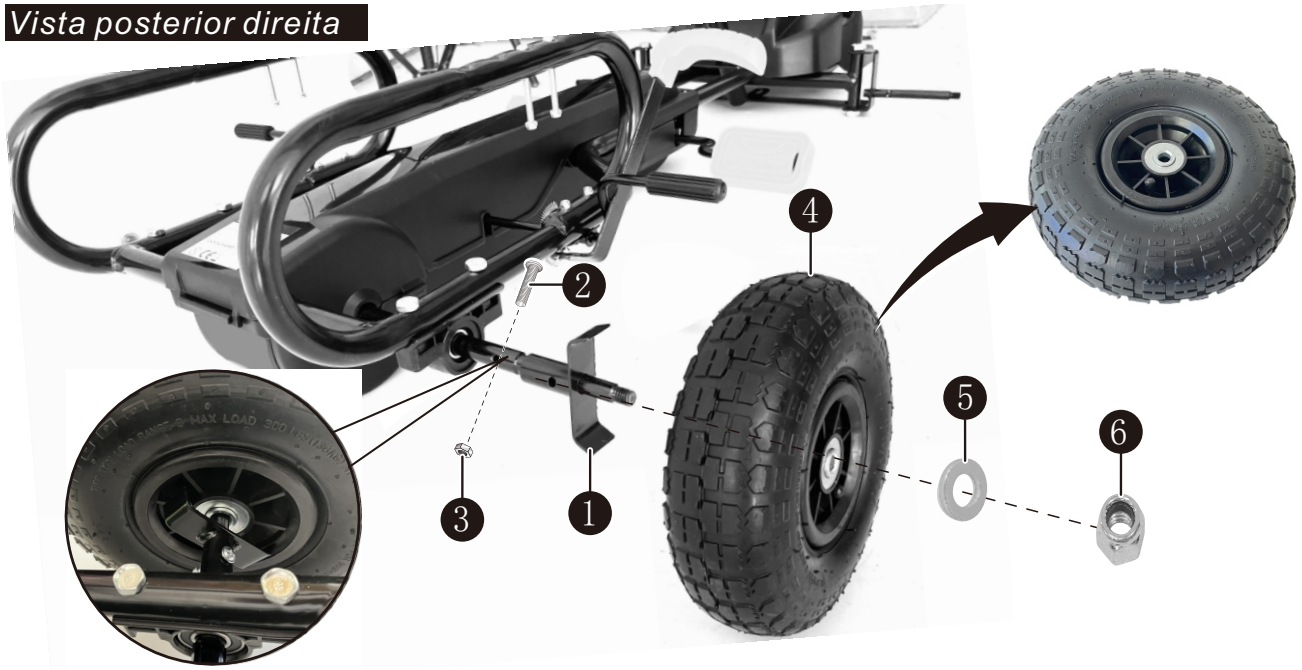

1. Deslizar o suporte de tracção para o eixo traseiro.
- 2-3. Fixar o suporte de transmissão ao eixo traseiro com parafusos M5*25 e porcas M5.
4. Deslizar a roda traseira para o eixo traseiro de modo a que seja ligada ao suporte de transmissão.
5. Deslizar uma arruela de 10 no eixo traseiro.
6. Apertar a porca M10 da fechadura até à extremidade do eixo traseiro com uma chave inglesa.

Vista traseira esquerda



7. Deslizar a roda traseira para o eixo traseiro.
8. Deslizar uma arruela de 10 no eixo traseiro.
9. Apertar a porca de fixação M10 até à extremidade do eixo traseiro com uma chave de porcas.

3. Fixar as Rodas Dianteiras e o Eixo Direccional



1. Deslize uma arruela 12 no eixo dianteiro.
2. Deslizar a roda para o eixo dianteiro.
3. Deslizar uma arruela de 10 no eixo dianteiro.
4. Apertar a porca de fixação M10 até à extremidade do eixo dianteiro utilizando uma chave inglesa.

Repetir para a outra roda da frente.

Virar o kart para o lado.

5. Coloque a arruela 10 no eixo de direcção. (Não retire a arruela do eixo de direcção)
6. Inserir o eixo de direcção através do suporte do eixo de direcção, certificar-se de que o outro gancho do eixo da frente se encontra no orifício de abertura.

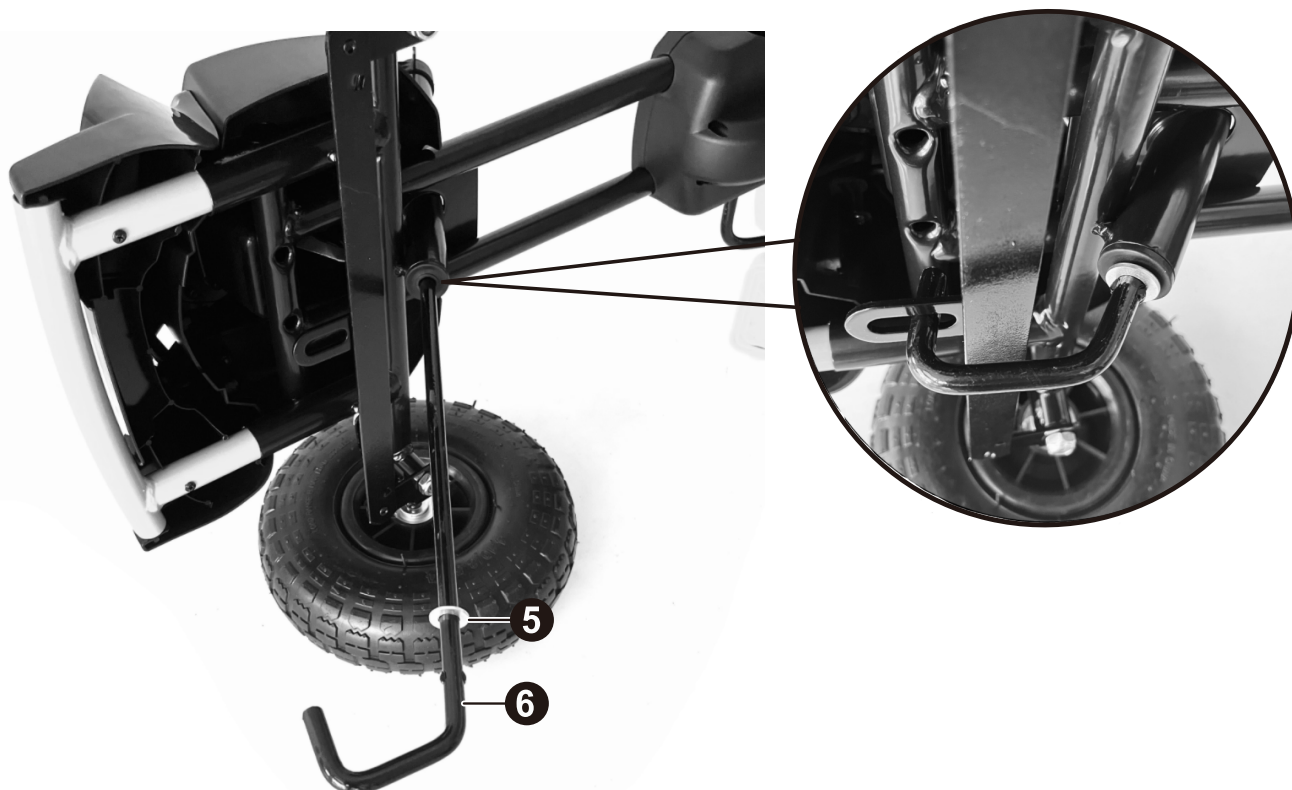

4. Fixar o Volante e a Cobertura Frontal

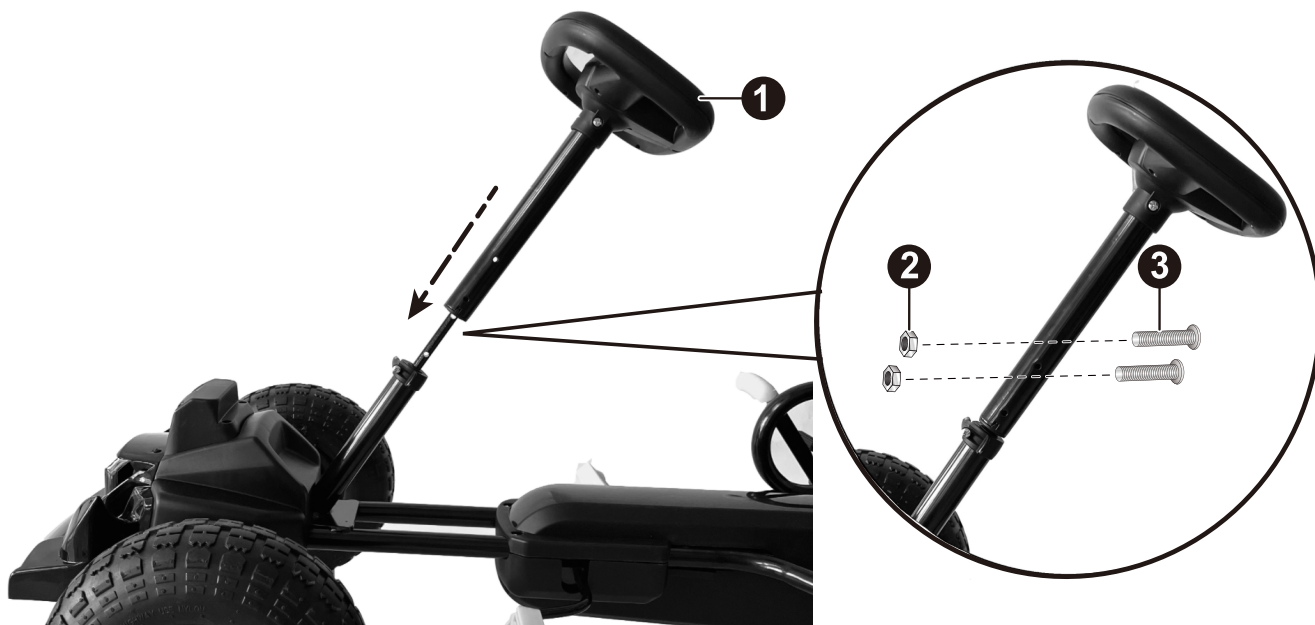

Remover o parafuso M5*32 e a porca M5 do volante.

1. Inserir o volante no fim do eixo direccional, alinhar os orifícios do volante e do eixo direccional.
- 2-3. Fixar com parafuso M5*32 e porca M5 o volante. Retirar o parafuso M4*14 da estrutura.
4. Alinhar a cobertura frontal e a estrutura e inserir o fundo na ranhura de abertura da estrutura.
5. Fixar com M4*14 aparafusar a cobertura frontal.



5. Fixar o Assento



Remover a porca M5*55mm e a M5 da estrutura.

1. Alinhar e montar o assento a estrutura
- 2-3. Fixar com porca M5*55mm e M5 o assento.

6. Fixar o para-lamas



Retirar os parafusos M5*10 da estrutura.

1. Colocar as pastilhas de argila sobre a estrutura e alinhá-las com os orifícios.
2. Utilizar o parafuso M5*10 para o fixar. Existem quatro pastilhas de argila. Por favor instale-as uma a uma.

Use o seu Novo Kart



1. **Travão:** Prime para abrandar ou travar o veículo.
2. **Pedal:** Para mover o veículo para a frente e para trás.
3. **Volante:** Controla a direcção do veículo.

Ajuste da Corrente

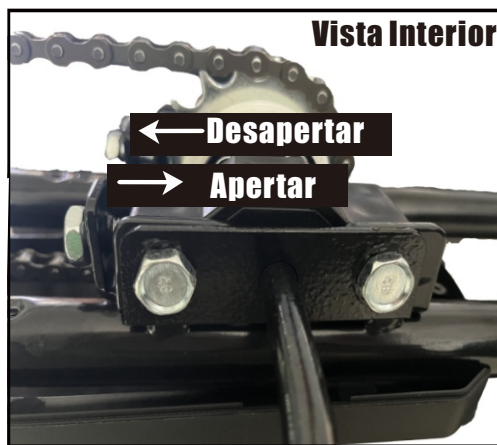
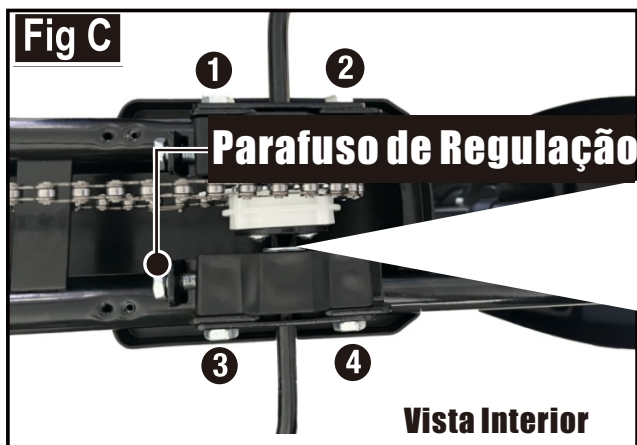
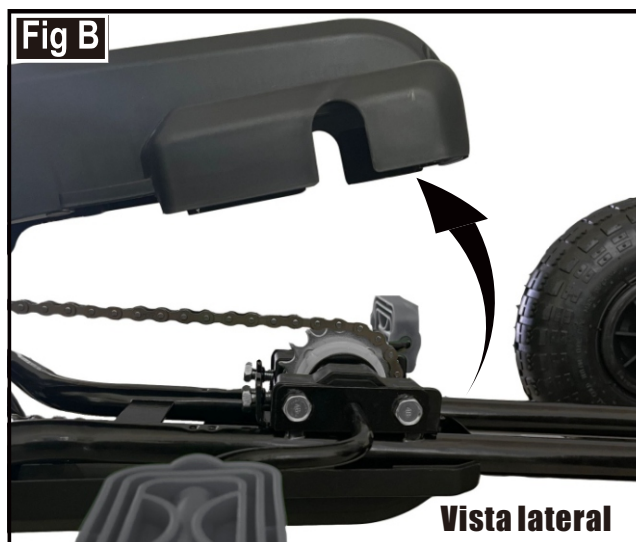
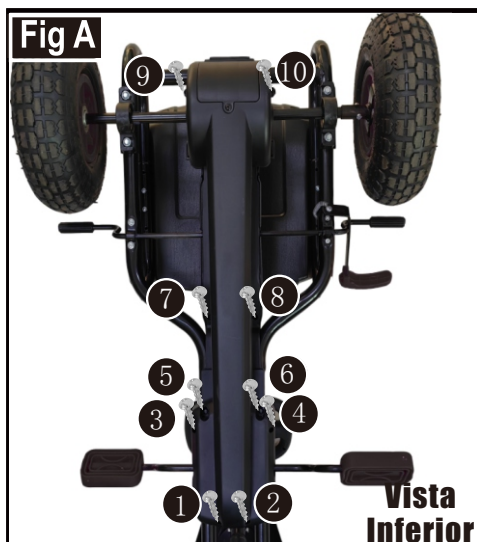

A corrente deve estar no aperto correcto. Se estiver demasiado apertada, o kart será difícil de pedalar. Se demasiado solta, a corrente pode sair das rodas dentadas.

A corrente deve estar no aperto da corrente da seguinte forma:

- A. Virar o produto para baixo. Retirar os seis parafusos na parte inferior do produto com uma chave de fendas.
- B. Pressionar as duas fivelas na lateral do produto. Levantar a cobertura da corrente.
- C. Desaperte os quatro parafusos fixos e ajuste os parafusos de acordo com o aperto da corrente.



Pedale GO per bambini Karting



Scansionare il codice QR
per il Video di Assemblaggio



Scansionare il codice
QR per il Video di
Catena mantiene.

ATTENZIONE: Età di certificazione: 5+ anni; Peso massimo: 50 kg.

IMPORTANTE! CONSERVARE IL PRESENTE MANUALE PER FUTURO RIFERIMENTO E LEGGERLO ATTENTAMENTE.

A x 1



B x 1



C x 1



D x 1



E x 1



F x 4



G x 1



H x 1



I x 4



J x 2

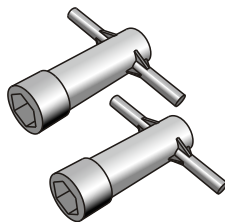

K x 1



Nota:

Tutte le viti, i dadi e le piccole parti in plastica sono preinstallate nella posizione corrispondente; seguire i passaggi per la rimozione prima di installare il prodotto.

- Attrezzi di montaggio necessari:



Cacciavite e Chiave inglese
(non inclusa)

⚠ AVVERTENZA:

1. RISCHIO DI SOFFOCAMENTO — Parti piccole. Non adatto a bambini sotto i 3 anni.
2. Consentire l'installazione solo agli adulti, tenere lontani i bambini.
3. Da utilizzare sotto la diretta supervisione di un adulto.
4. Consentire l'uso un bambino alla volta.
5. Si prega di utilizzare su una superficie in piano e pulita. Non usare mai vicino a gradini, passi carrai in pendenza, strade in collina, vicoli, piscine, strade, su erba o superfici bagnate o altre fonti d'acqua.
6. Prima di guidare ogni volta il veicolo, l'adulto dovrebbe ispezionare le viti di tutte le parti, e stringere i dadi in caso di allentamento. Stringere tutti i dispositivi di fissaggio prima di ogni viaggio.
7. Indossare sempre scarpe e dispositivi di protezione adeguati. Indossare sempre un casco approvato dalla normativa locale durante la guida, con il cinturino fissato saldamente.
8. Non guidare il prodotto al crepuscolo, di notte o in momenti di visibilità limitata.
9. Rispettare sempre le leggi e le normative locali.

MANUTENZIONE & CURA

- A. Conservare tutte le istruzioni e le parti relative a questo prodotto per riferimenti futuri.
- B. Verificare regolarmente la presenza di danni e che tutte le viti siano strette saldamente.
- C. Verificare che il sedile sia fissato in sicurezza.
- D. Lubrificare la catena tutte le volte che è necessario.
- E. Controllare regolarmente la pressione degli pneumatici.

1. Montaggio della piastra di collegamento dello sterzo

Vista dal fondo



Tagliare le fascette e rimuovere la staffa dello sterzo

1. Allentare la vite M10*90 mm e poi posizionare la staffa dello sterzo sul corpo.
- 2-3. Avvitare la staffa di sterzo con la vite M10*90 mm e il dado M10.

2. Montaggio delle ruote posteriori

Vista posteriore destra

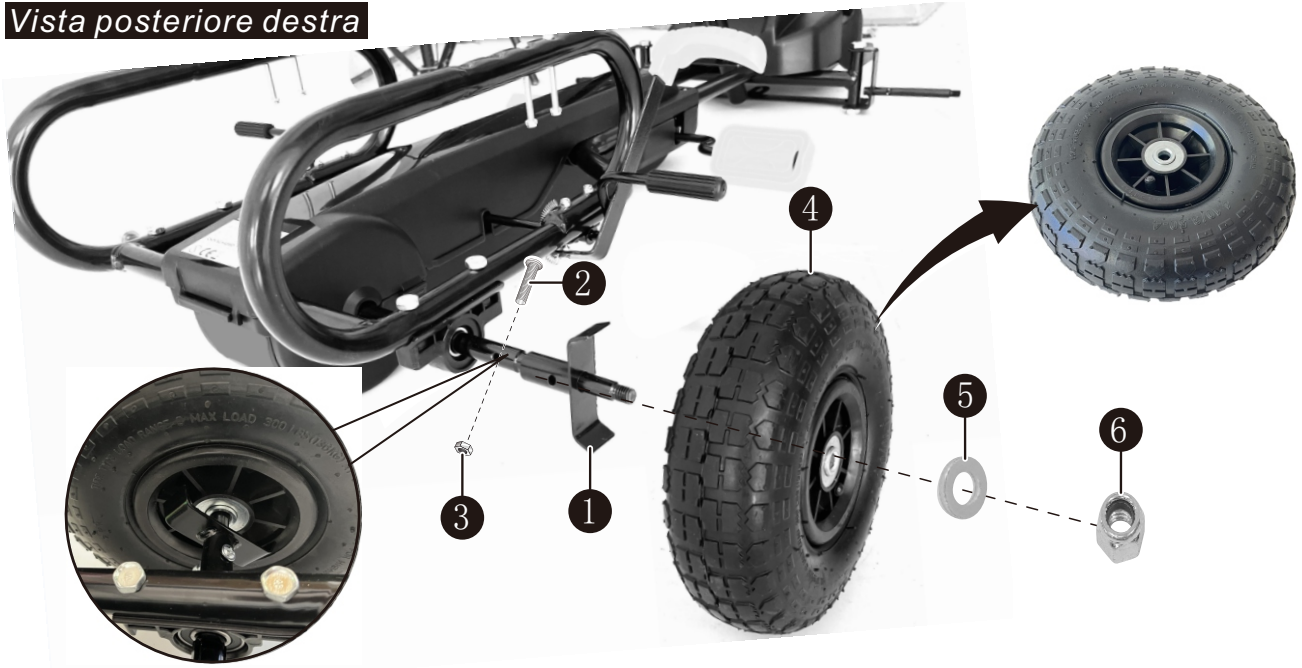

1. Far scorrere la staffa di trasmissione nell'assale posteriore.
- 2-3. fissare la staffa di trasmissione all'assale posteriore con viti M5*25 e dadi M5.
4. Far scorrere la ruota posteriore nell'assale posteriore in modo che sia collegata alla staffa di trasmissione.
5. Far scorrere una rondella 10 sull'assale posteriore.
6. Serrare il dado di bloccaggio M10 all'estremità dell'asse posteriore con una chiave.

Vista posteriore sinistra view



7. Far scorrere la ruota posteriore nell'assale posteriore.
8. Far scorrere una rondella 10 sull'asse posteriore.
9. Serrare il dado di bloccaggio M10 all'estremità dell'asse posteriore con una chiave.

3. Montaggio delle ruote anteriori & dell'asse sterzante



1. Far scorrere una rondella 12 sull'assale anteriore.
2. Far scorrere la ruota nell'assale anteriore.
3. Far scorrere una rondella 10 sull'assale anteriore.
4. Serrare il dado di bloccaggio M10 all'estremità dell'asse anteriore con una chiave.

Ripetere l'operazione per l'altra ruota anteriore.

Girare la Karting su un lato.

5. Mettere la rondella 10 sull'asse dello sterzo (non rimuovere la rondella dall'asse dello sterzo).
6. Inserire l'asse di sterzo attraverso il supporto dell'asse di sterzo, assicurandosi che l'altro gancio sia in corrispondenza del foro di apertura sull'asse anteriore.

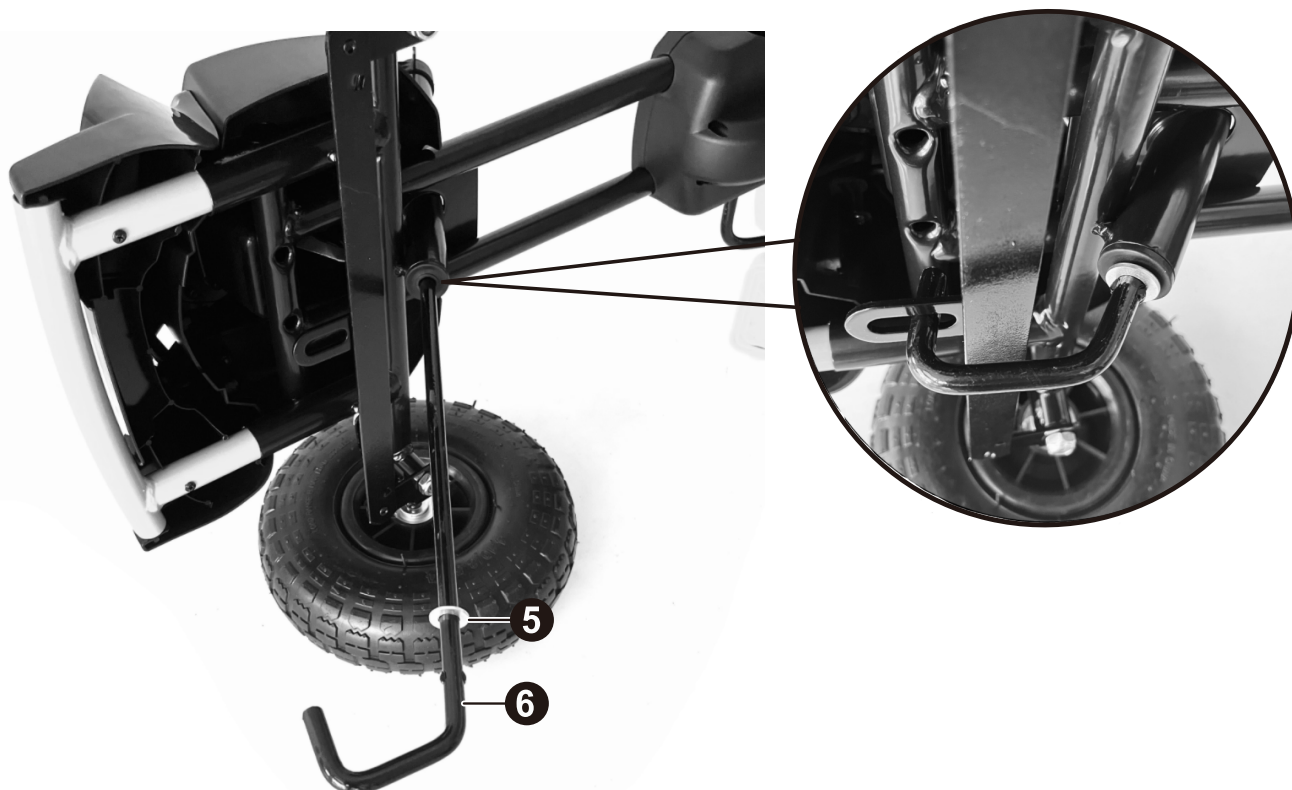

4. Montaggio del Volante & del Coperchio anteriore

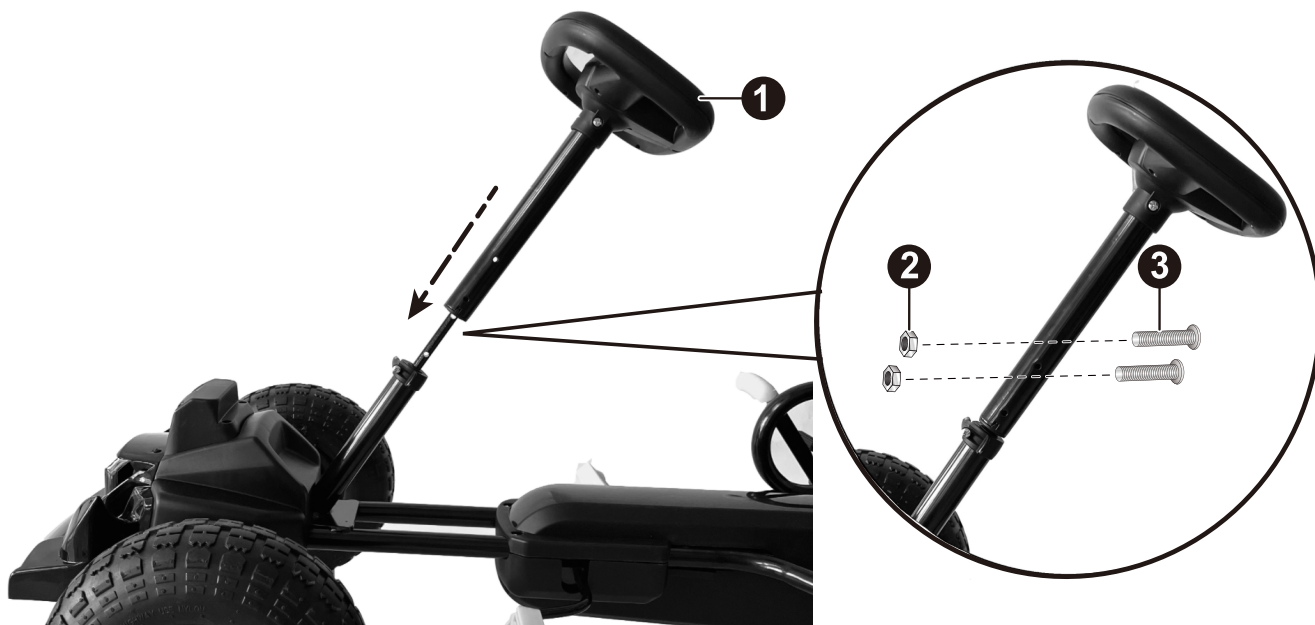

Rimuovere la vite M5*32 e il dado M5 dal volante.

1. Inserire il volante all'estremità dell'asse dello sterzo, allineare i fori del volante e dell'asse dello sterzo,

2-3. Fissare il volante con una vite M5*32 e un dado M5.

Rimuovere la vite M4*14 dal corpo.

4. Allineare il coperchio anteriore e il corpo e inserire la parte inferiore nella scanalatura aperta del corpo,

5. Fissare il coperchio anteriore con una vite M4*14.



5. Montaggio del Sedile



Rimuovere il dado M5*55 mm e M5 dal corpo.

1. Allineare e assemblare il sedile al corpo.
- 2-3. Fissare il sedile con dado M5*55m e dado M5

6. Montare il parafango



Rimuovere le viti M5*10 dal telaio.

1. Posizionare il parafango sul telaio e allinearle ai fori.
2. Utilizzare la vite M5*10 per fissarle. Ci sono quattro parafanghi. Installarle una dopo l'altra.

Utilizzare la tua nuova Karting



1. **Freno:** premere per rallentare o frenare il veicolo.
2. **Pedali:** per muovere il veicolo in avanti e in retromarcia.
3. **Volante:** per controllare la direzione del veicolo.

Regolazione della Catena

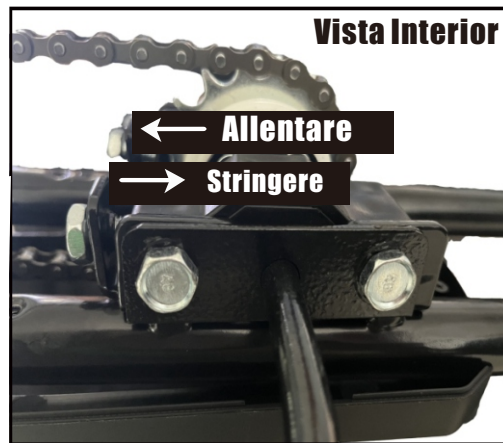
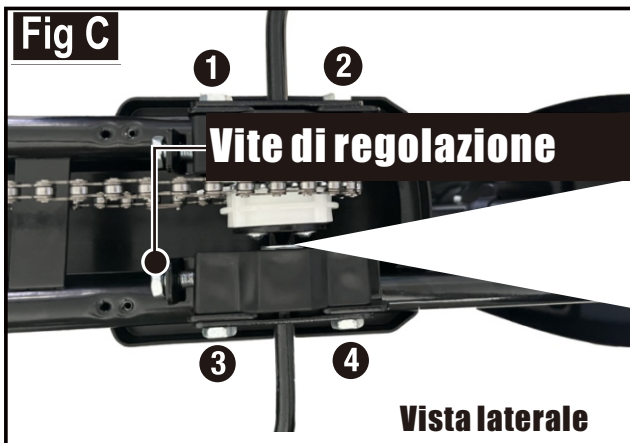
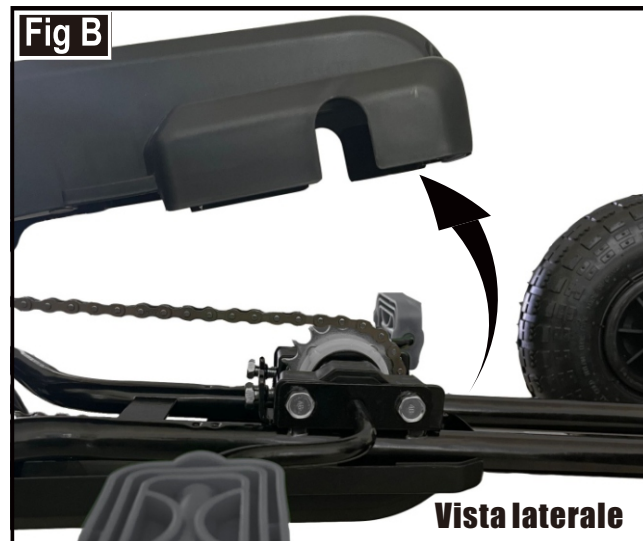

La catena deve avere il giusto serraggio: se troppo stretta, la Karting sarà difficile da pedalare. Se troppo allentata, la catena può staccarsi dalle ruote dentate.

Regolare il serraggio della catena come segue:

- A. Capovolgere il prodotto e rimuovere le sei viti sul fondo del prodotto con un cacciavite.
- B. Premere le due fibbie sul lato del prodotto e sollevare il coperchio della catena.
- C. Allentare le quattro viti fisse e regolare le viti in base alla tenuta della catena.

UK

If you have any questions, please contact our customer care center.

Our contact details are below:



0044-800-240-4004



enquiries@mhstar.co.uk

IMPORTER ADDRESS:

MH STAR UK LTD

Unit 27, Perivale Park,
Horsenden lane South

Perivale, UB6 7RH

MADE IN CHINA

ES

Si tiene alguna pregunta, comuníquese con nuestro Centro de Atención al Cliente. Nuestros datos de contacto son los siguientes:



0034-931294512



atencioncliente@aosom.es

IMPORTADOR:

SPANISH AOSOM, S.L.

C/ ROC GROS, N° 15. 08550, ELS HOSTALETS DE
BALENYÀ, SPAIN.

B66295775

WWW.AOSOM.ES

ATENCIONCLIENTE@AOSOM.ES

TEL: 931294512

HECHO EN CHINA

FR

Si vous avez la moindre question, veuillez contacter notre centre d'assistance à la clientèle.

Nos coordonnées sont les suivantes:



0033-1-84166106



aosom@mhfrance.fr

Importé par:

MH France

2, rue Maurice Hartmann

92130 Issy-les-Moulineaux

France

Fabriqué en Chine

PT

Se tiver alguma dúvida, por favor contacte o nosso Centro de Atendimento ao Cliente. Os nossos dados de contacto são os seguintes:



0034-931294512



atencioncliente@aosom.es

IMPORTADOR:

SPANISH AOSOM, S.L

C.ROC GROS N.15, 08550. ELS HOSTALETS DE BALENYÀ

TEL: 931294512 (SEG-SEX DAS 7:30H ÀS 16:30H)

INFO@AOSOM.PT

WWW.AOSOM.PT

DE

Wenn Sie Fragen haben, wenden Sie sich bitte an unser Kundendienstzentrum.

Unsere Kontaktdaten stehen unten:



0049-0(40)-88307530



service@aosom.de

ADRESSE DES IMPORTEURE:

MH Handel GmbH

Wendenstraße 309

D-20537 Hamburg

Germany

IN CHINA HERGESTELLT

IT

In caso di dubbio, si prega di contattare il nostro centro assistenza clienti. I nostri dettagli di contatto sono di seguito:



0039-0249471447



clienti@aosom.it

IMPORTATO DA:

AOSOM Italy srl

Centro Direzionale Milanofiori

Strada 1 Palazzo F1

20057 Assago (MI)

P.I.: 08567220960

FATTO IN CINA



FR

DONNEZ
OU
RECYCLEZ



OU

ASSOCIATION



OU

LIVRAISON



DÉCHÈTERIE

Adresses sur quefairedemesdechets.fr

Aosom