

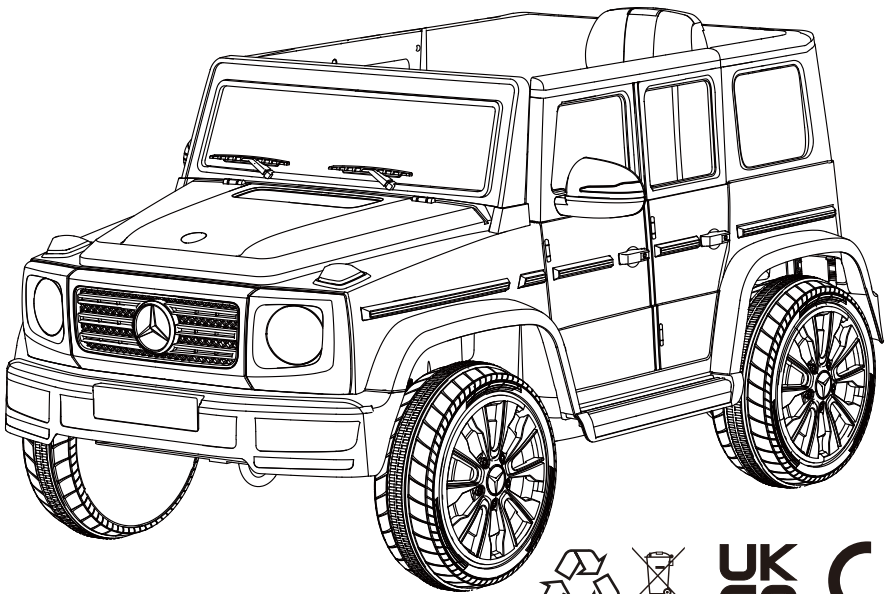



IN230300195V01_UK

370-148V70



“Mercedes-Benz”   and the design of the enclosed product are subject to intellectual property protection owned by Daimler AG. They are used by Zhejiang Jiajia Ride-On Co., Ltd. under license.

IMPORTANT, RETAIN FOR FUTURE REFERENCE: READ CAREFULLY

ASSEMBLY INSTRUCTION

SPECIFICATIONS:

Battery:	12V4.5AH *2
Motor:	2*390(25W)
Suitable ages:	37-96 months
Maximum weight:	30KG
Speed :	1WD 3KM/h 2WD 3-5KM/h
Power way:	Charging type
Use of time:	Charg: 8-12 hours ; Use: 1-2 hours
Charger:	Input AC 110 V~240, output DC12V 500mA

WARNING

1.The pictures in this instruction is only for explaining the operation and structure of the product, when there's any difference with the real product, please confirm with the real product.

2.In order to improve the quality of the product, we may amend some structure or appearance of the product without notification. Thank you for your understanding.

FOR THE SAFETY OF YOUR CHILD, PLEASE READ ALL WARNINGS AND ASSEMBLY/USE INSTRUCTIONS. KEEP THIS GUIDE FOR FUTURE REFERENCE.

●ADULT ASSEMBLY REQUIRED. The product contains small parts, which are for adult assembly only. keep small children away when assembling.

●always remove protective material and poly bags and dispose before assembly.

●never leave child unattended. direct adult supervision is required.

●always keep child in view when child is in vehicle.

●Keep Children within Safe Riding Areas:

- Never use in roadways, near motor vehicles, on lawn space, on or near steep inclines or steps, swimming pools or or any other dangerous area.

●Use the toy only on flat surfaces. Such as inside your house, garden or playground.

●Never use in the dark. A child could encounter unexpected obstacles and have an accident. Operate the vehicle only in the daytime or a well-lit area.

●Please avoid running on sand or any other rough ground.

●always wear shoes.

●always sit on the seat.

●this has no brake.

●It is prohibited to change the circuit or add other electric parts

●Inspect wires and connections of the vehicle periodically.

●Do not let any child touch the wheels or be near them when the car is moving.

●This vehicle has adjustable play seat belts. Please instruct children how to tie the safety belt before using, guarantee the security.

STORAGE BATTERY INFORMATION AND MAINTENANCE

- Please charge 8 to 12 hours before first time use.
- Please use the suitable adapter to charge storage battery, otherwise the ride-on will be damaged.
- Please charge the car once the speed is slower than normal, otherwise it will decrease storage battery life.
- Please fully charge the battery before you put your ride-on away, and remember to recharge the battery every 30 days. This will ensure the normal use of the battery, otherwise, the battery might not hold a charge without proper maintenance.
- Batteries may leak fluids that can cause chemical burn injury or ruin your product.
- To avoid battery leakage: Do not mix old and new batteries or batteries of different types: alkaline, standard (carbon-zinc) or rechargeable (nickel-cadmium).
- Insert batteries as indicated inside the battery compartment. Remove batteries during long periods of non-use.
- Always remove exhausted batteries from the product. Dispose of batteries safely. Do not dispose of batteries in a fire. The batteries may explode or leak.
- Never short-circuit the battery terminals.
- Non-rechargeable batteries are not to be recharged.
- Use only batteries of the same or equivalent type as recommended.
- Do not charge non-rechargeable batteries.
- Remove rechargeable batteries from the product before charging.
- If removable rechargeable batteries are used, they are only to be charged under adult supervision
- Every single charging can not go over 20 hours. Both charger and storage batteries will occur mildly warm during charging. Do not use mal-functioned adapter or storage battery unless they are repaired.
- Charger and storage batteries are not considered as toys.
- Please make periodical inspection for storage battery, especially for adapter wires and plugs.
- Please turn off the switch when the ride-on is not in use. Please do a full charge after long periods of inactivity.
- Charge in well ventilated, dry place. Do not open the battery or the charger.
- Tighten the screws with a screwdriver. DO NOT over tighten

Disposal Of Battery:

1. Your sealed lead-acid battery must be recycled or disposed of in an environmentally sound manner.
2. Do not dispose of your lead-acid battery in a fire. The battery may explode or leak.
3. Do not dispose of a lead-acid battery in your regular, household trash. The incineration, land filling or mixing of sealed lead-acid batteries with household trash is prohibited by law.

PREVENT FIRE AND ELECTRIC SHOCK:

- Use the only rechargeable battery and charger supplied with your vehicle.
 - NEVER substitute the battery or the charger with another brand. Using another battery or charger may cause a fire or explosion.
 - Do not use the battery or charger for any other product. Overheating, fire or explosion could occur.
 - NEVER modify the electric circuit system. Tampering with the electric system may cause a shock, fire or explosion or may permanently damage the system.
 - Do not allow direct contact between battery terminals. Fire or explosion can occur.
 - Do not allow any type of liquid on the battery or its components.
 - Explosive gasses are created during charging. Do not charge near heat or flammable materials. Charge the battery in a well- ventilated area ONLY.
 - NEVER pick up the battery by the wires or charger. Damage can occur to the battery and may cause a fire. Pick up the battery by the case ONLY. Charge the battery in a dry area ONLY.
 - Battery posts, terminals and related accessories contain lead and lead compounds, chemicals known to the State of California to cause cancer and reproductive harm. Wash hands after handling.
 - Do not open the battery. Battery contains lead acid and other materials that are toxic and corrosive.
 - Do not open the charger. Exposed wiring and circuitry inside case may cause electric shock.
- ONLY adults may handle or charge the battery. NEVER allow child to handle or charge the battery. Battery is heavy and contains lead acid (electrolyte).
- Do not drop the battery. Permanent damage to the battery could occur or cause serious injury.
 - Before charging the battery, check for wear or damage to the battery, charger, its supply cord and the connectors. DO NOT charge the battery if any damage to parts has occurred.
- Do not allow the battery to drain completely. Recharge the battery after each use or once a month if not used regularly.
- Do not charge battery upside down.
 - Always secure the battery with the bracket. Battery can fall out and injure a child if vehicle tips over.
 - It is parents' responsibility to check main parts of the toy before using, Must regularly examine for potential hazard, such as the battery, charge, cable or cord, plug, screws are fastening enclosure of other parts and that in the event of such damage, the toy must not be until that damage had been properly removed. Make sure the plastic parts of the vehicle are not cracked or broken.
 - Occasionally use a lightweight oil to lubricate moving parts such as wheels.
 - Park the vehicle indoors or cover it with a tarp to protect it from wet weather.
 - Keep the vehicle away from sources of heat, such as stoves and heaters. Plastic parts may melt.

- Recharge the battery after each use. Only an adult can handle the battery. Recharge the battery at least once a month when the vehicle Raider is not being used.
- Do not wash the vehicle with a hose. Do not wash the vehicle with soap and water. Do not drive the vehicle in rainy or snowy weather. Water will damage the motor, electric system and battery.
- Clean the vehicle with a soft, dry cloth. To restore shine to plastic parts, use a non-wax furniture polish. Do not use car wax. Do not use abrasive cleaners.
- Do not drive the vehicle in loose dirt, sand or fine gravel which could damage moving parts, motors or the electric system.
- When not using, all the electrical source should be turn off. Turn off the power switch and disconnect the battery connection.

Parts Diagram | 2

HINT: Some parts shown are assembled on both sides of vehicle

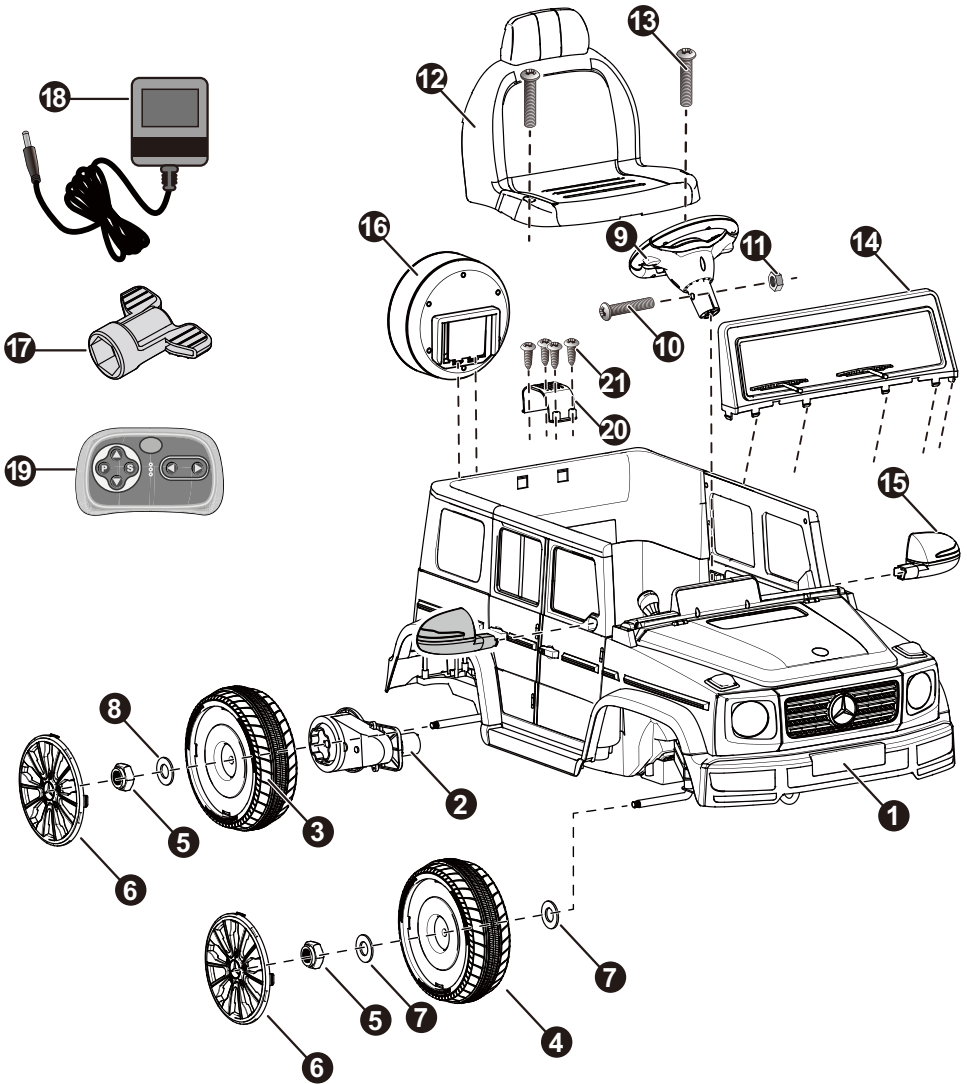

Parts List | 3

PART NO.	PART NAME	Q'ty (pcs)		REMARKS
		1WD	2WD	
1	Vehicle body	1	1	
2	Rear gear box	1	2	2WD 1 PC labeled "R", the other one labeled "L"
3	Rear wheel	2	2	
4	Front wheel	2	2	
5	Lock nut	4	4	
6	Hubcap	4	4	
7	Ø10 washer	4	4	Placed on the front axle
8	Ø12 washer	3	2	Placed on the rear axle
9	Steering wheel	1	1	
10	M5x35 machine screw	1	1	Placed on the steering wheel
11	Ø5 nut	1	1	Placed on the steering wheel
12	Seat	1	1	
13	M5x16 screw	2	2	
14	Windshield	1	1	
15	View mirror	2	2	Left and right
16	Spanner	1	1	
17	Tool box	1	1	
18	Charger	1	1	
19	Remote controller	1	1	For R/C type only
20	Motor hood	1	\	1WD type only
21	Ø4x12 screw	4	\	1WD type only

Assembly tools required (not included):



Screwdriver

HINT: If your vehicle is Two Wheels Driving Type, see the next page please.

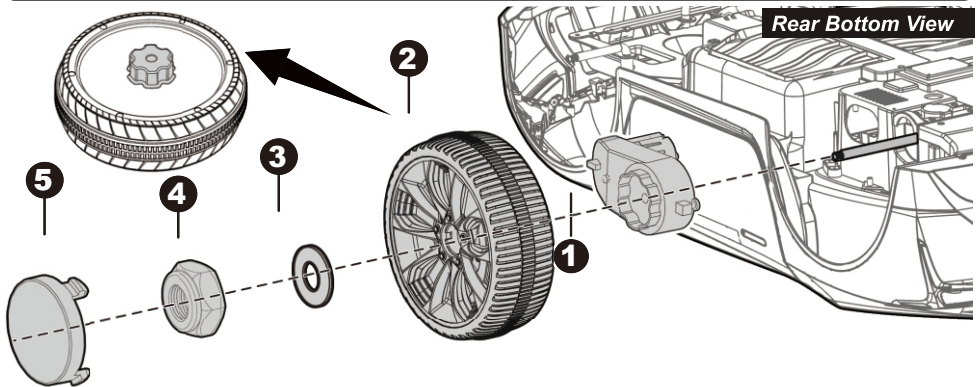

Remove all the parts from the rear axle.

1. Slide the rear gear box onto the rear axle from Left Side keep the connector and the motor on the gear box pass through the larger hole and out where the battery sits.
2. Slide the **rear wheel** onto the rear axle. Keep it match up with the gear box.
3. Slide a **Ø12 washer** onto the rear axle.
4. Tighten a **lock nut** to the end of the rear axle with a spanner.
5. Fit the **wheel cover** to the wheel.

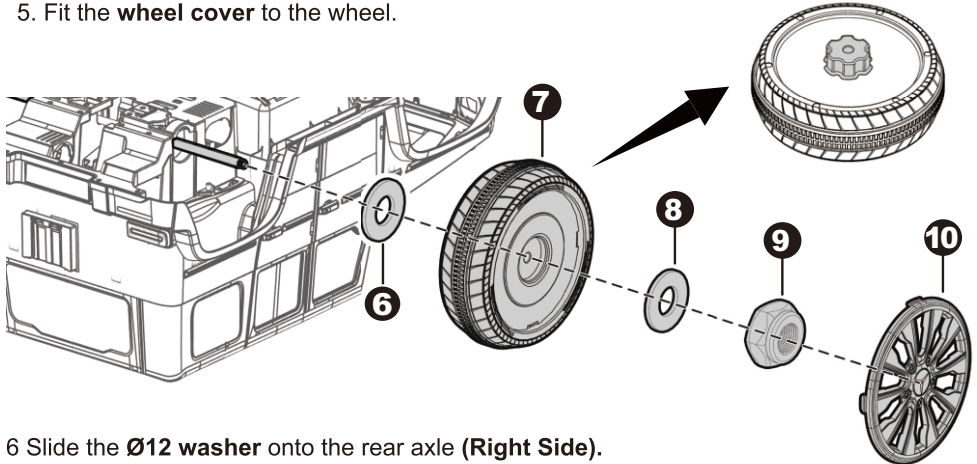

- 6 Slide the **Ø12 washer** onto the rear axle (**Right Side**).
7. Slide the **rear wheel** onto the rear axle.
8. Slide the **Ø12 washer** onto the rear axle.
9. Tighten a **lock nut** to the end of the rear axle with a spanner. **HINT: An extra spanner has been provided to hold the Lock Nut on the other side of the rear axle while tightening the Lock Nut on the other side.**
10. Fit the **wheel cover** to the wheel.

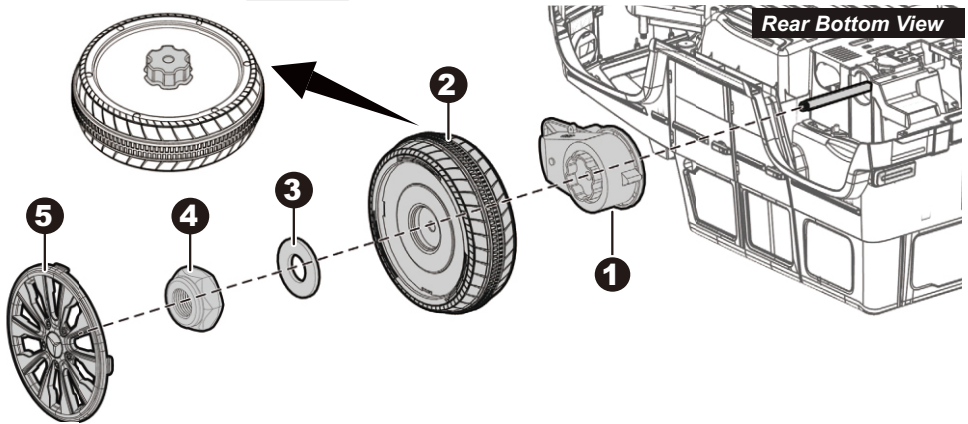

Remove all the parts from the rear axle.

1. Slide the **rear gear box** onto the rear axle. "R" labeled gear box should be fit to the "R" side of vehicle body; "L" labeled gear box should be fit to "L" side of vehicle body. Keep the motor and the connector on the gear box pass through the larger hole on the rear of the vehicle and out where the battery sits.
2. Slide the **rear wheel** onto the rear axle. And keep the driving wheel match up with the gear box.
3. Slide the **Ø12 washer** onto the rear axle.
4. Tighten a **lock nut** to the end of the rear axle with a spanner.
5. Fit the **wheel cover** to the wheels.

Repeat the above procedure to assemble the other rear wheel.

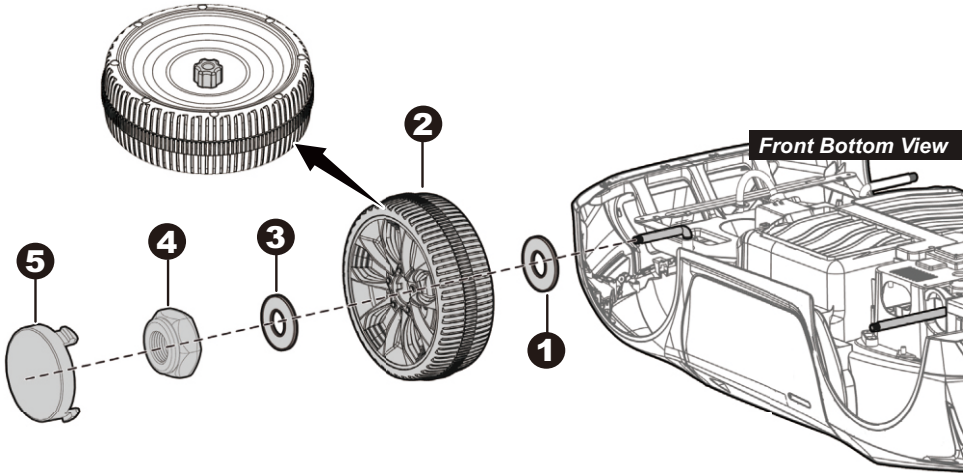

Remove all the parts from the front axle.

1. Slide a **Ø10 washer** onto the front axle.
2. Slide a **front wheel** onto the front axle.
3. Slide a **Ø10 washer** onto the front axle.
4. Tighten a **lock nut** to the end of the front axle with a spanner.
5. “Snap” the **wheel cover** to the wheel.

Repeat the above procedure to assemble the other normal wheel.

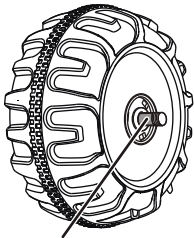

GAP

After assembling any wheel to the axles, please check the gap between the screw thread and the collapsible (refer to below picture), if the gap is too big, please add two or three washers inside the wheel, but after tightening the nut outside the wheel, please turn the wheel by your finger to check if the wheel can run smoothly, this is very important, because if the wheel can run smoothly, it is ok, but if the nut presses the wheel and the wheel can't run smoothly, the motor will be broken easily! Then you need to decrease one or two washers to make sure the wheel can run smoothly!

Attach the Steering Wheel | 7

HINT: If the steering wheel of your vehicle equipped with the sound function, please follow the steps 1-4 to add the batteries (Not Included), and refer to the battery information on page 2.

1. With a screwdriver remove the screw on the **battery cover** located in the center of the steering wheel.
2. Remove the **battery cover** from the top of the **battery compartment**.
3. Insert 2x1.5 AA batteries in their correct polarities.
4. Place the **battery cover** over the **battery compartment** and fasten with the screw you removed in step one.

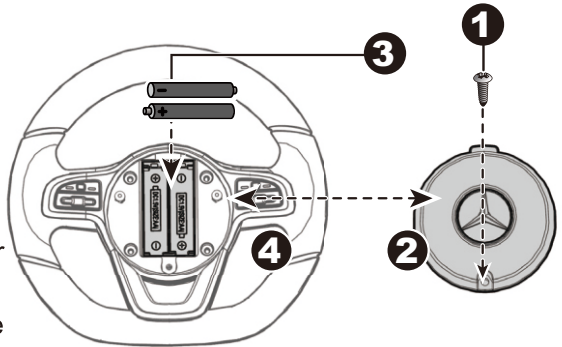

Attach the Steering Wheel

Remove the **M5x35 machine screw** and **Ø5 nut** from the **steering wheel**. Turn the vehicle body upright.

5. Place the **steering wheel** over the the steering column, protruding from the middle of the **steering wheel base**.
6. Align the holes on each side of **steering wheel with the holes at the end of the steering column**.
7. Fasten a **nut** on the **opposite end of the screw** to secure the steering wheel to the steering column.

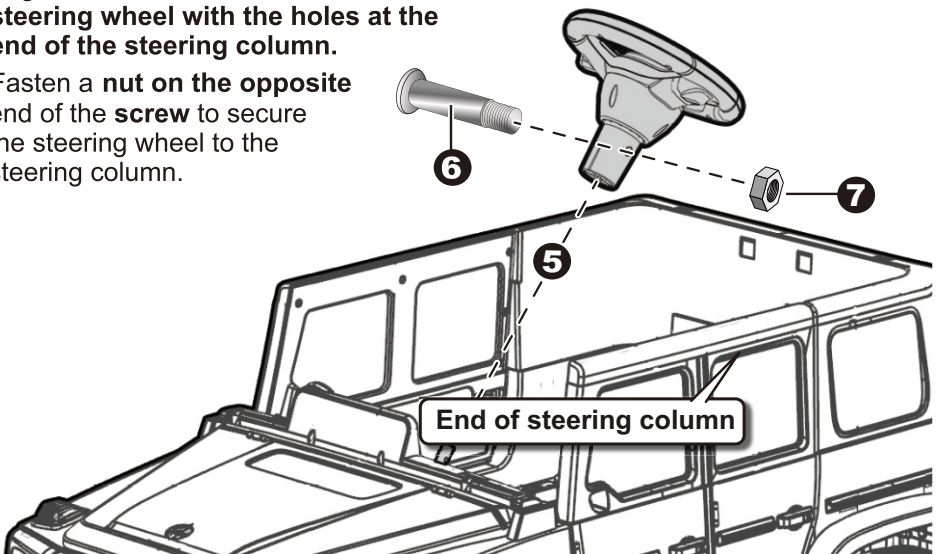

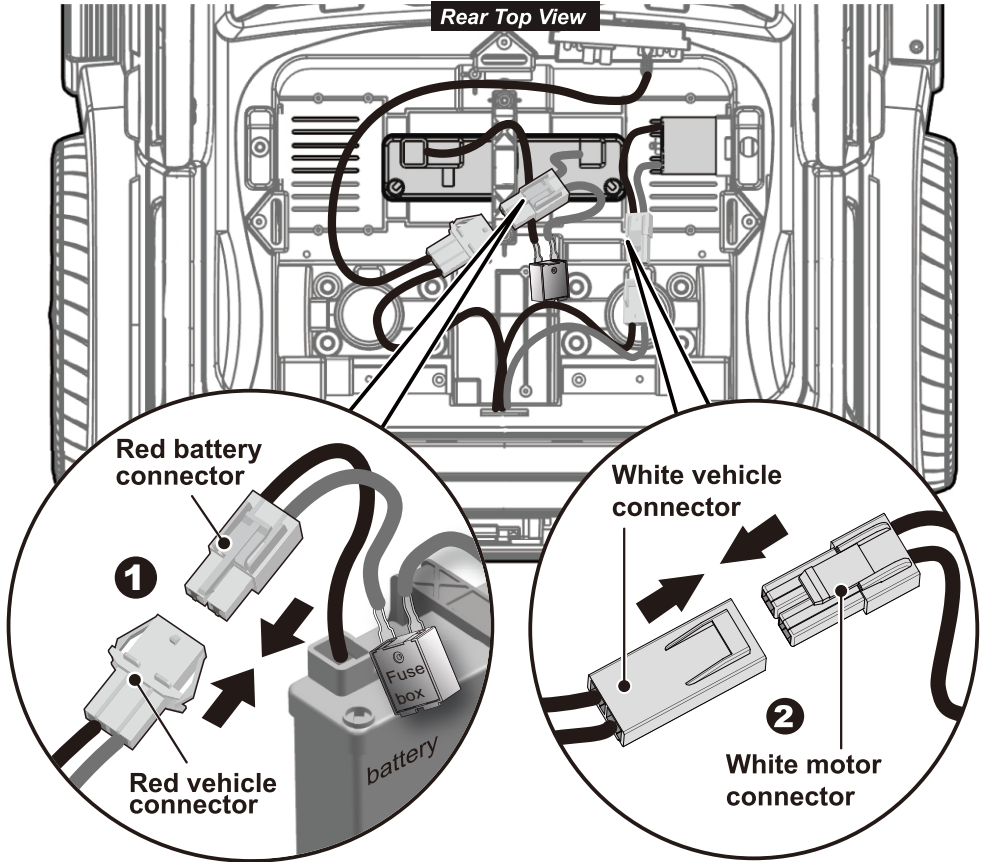

1WD

1. Plug the **vehicle connector** into the connector on the battery.
2. Plug the **vehicle connector** into the **motor connector** on body as shown above.

2WD

1. Plug the **vehicle connector** into the connector on the battery.
2. Plug the **vehicle connector** into the **motor connector** on body as shown above. Repeat for the other side.

HINT: Only 1WD product needs to assemble the motor hood

1. Fit the **motor hood** over the motor.
2. Insert two **Ø4x12 screws** and tighten.

1WD

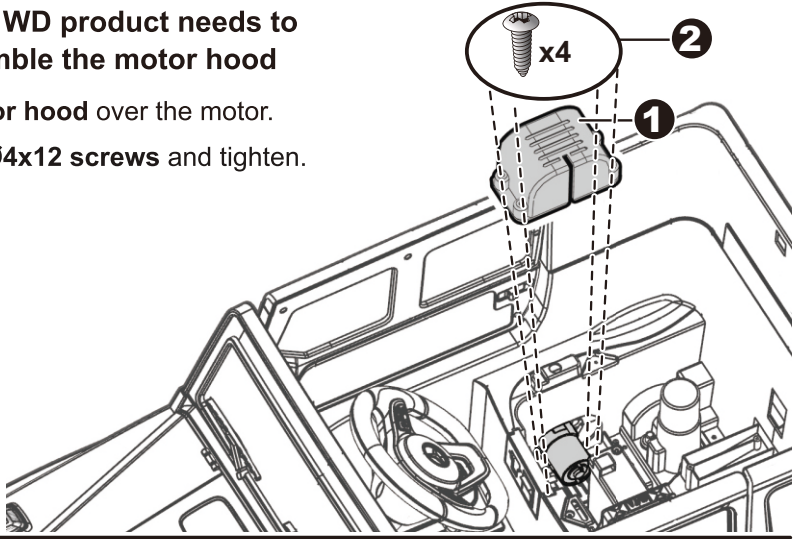

1. Fit the tabs on the seat back into the grooves on the rear of the vehicle.
2. Insert two **M5x16 machine screws** through the seat and into the vehicle body, and tighten them with a screwdriver.

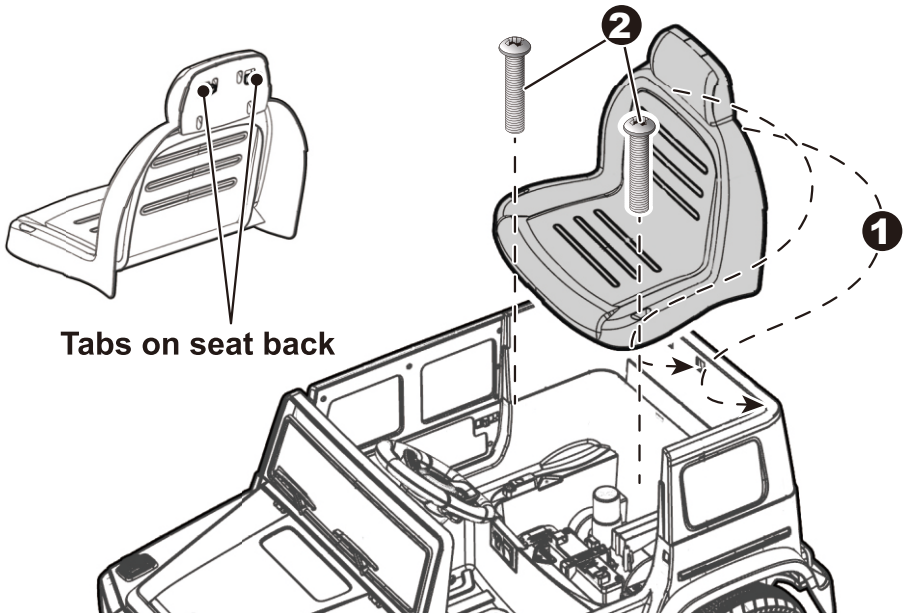

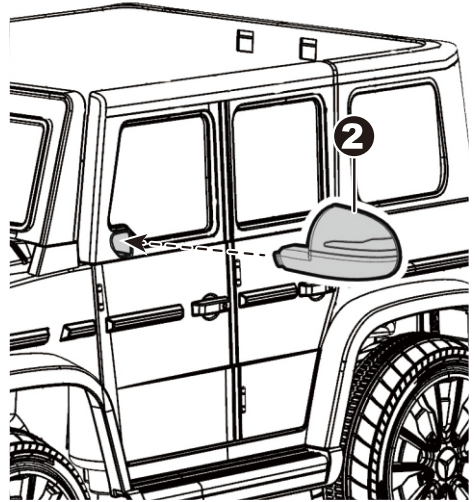
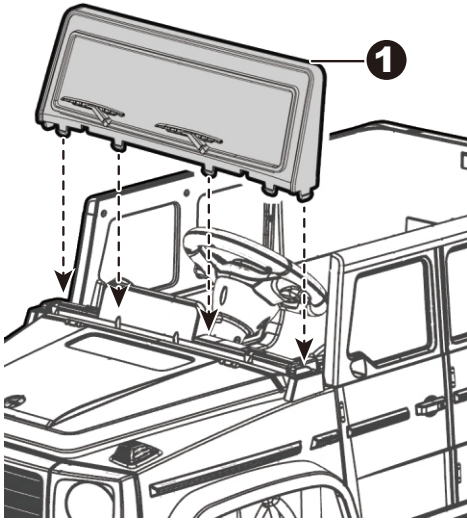

1. Fit the tabs **windshield** into the grooves on the vehicle. Press until you hear it “click” into place.
2. Fit the side mirrors to the holes on the side of the doors, push until you hear it “click” into place.
3. Fit the tool box to the back of the vehicle body. Press until you hear it “click” into place.

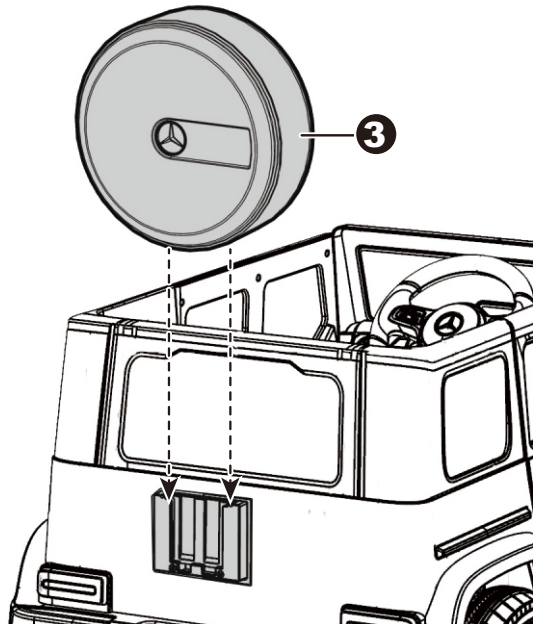

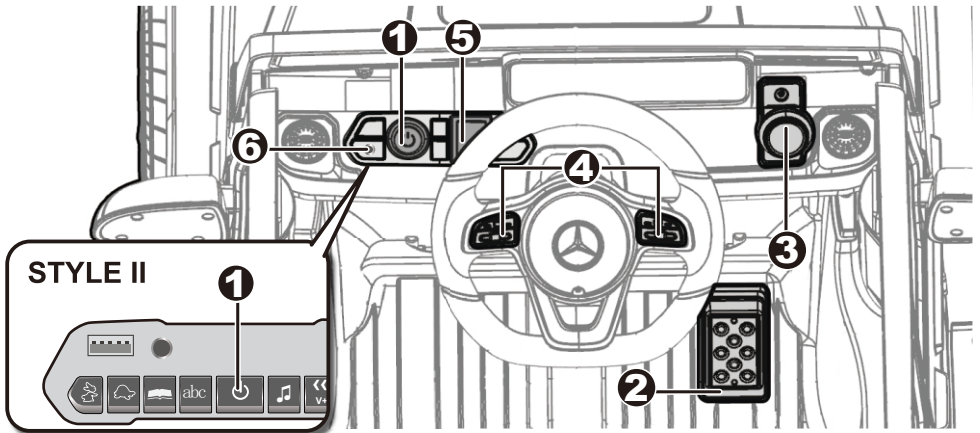

1. **Power button:** Turns the vehicle on and off.
2. **Foot pedal:** Applies power (speed) to the vehicle.
 - To move the car, press the pedal down.
 - To brake or slow down, release pressure from the pedal.
3. **Forward/reverse switch:** Changes the direction that vehicle moves from forward to reverse.
 - To move the vehicle forward, shift the lever to top position.
 - To move the vehicle backward, shift the lever to down position.
4. **Sound buttons (if equipped): Press for sound playing.**
5. **High/Low speed switch (if equipped):**
Operates the vehicle to move forward in high speed or low speed.
HINT: The vehicle is designed to operate in low speed only in reverse.
6. **3.5mm AUX input (if equipped):** Allow the audio from your portable music player or phone to be played through the ride-on speakers.

⚠ IMPORTANT

- Always stop vehicle when changing the speed (if equipped) or direction to avoid damage the gears and motor.
- **HIGH SPEED (if equipped):** Make sure your child knows how to steer, how to start and stop the product and knows the rules for safe driving.



Use the vehicle on generally level ground ONLY!

DO NOT Use the vehicle on Lawn space!

WARNING!

- **ONLY** an adult is allowed charge and recharge the battery!
 - This product with **Charging Protection**: when charging, all functions will be cut off.
- The POWER SWITCH must be turned in **OFF** position when charging.
 - Before the first use, you should charge the battery for 4-6 hours. Do not recharge the battery for more than 10 hours to avoid overheating the charger.
 - When the vehicle begins to run slowly, recharge the battery.
 - After each use or once a month minimum recharge time as 8 to 12 hours, less than 20 hours at most.
 - Use the only rechargeable battery and charger supplied with your vehicle. **NEVER** substitute the battery or the charger with another brand. Using another battery or charger may cause a fire or explosion.
 - Do not use the battery or charger for any other product.
 - If your ride-on with a **Digital voltmeter(IF EQUIPPED)**, the magnitude of voltage will tell you how much power is remaining in the battery when you must recharge the battery. Make sure the vehicle is stop!

6V product	less than 6.2	The battery needs to be charge.
12V product	less than 12.5	

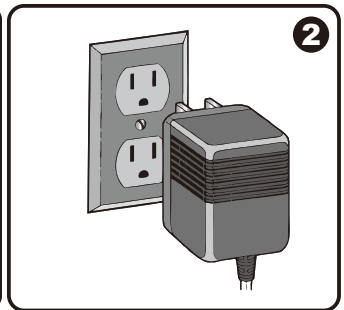
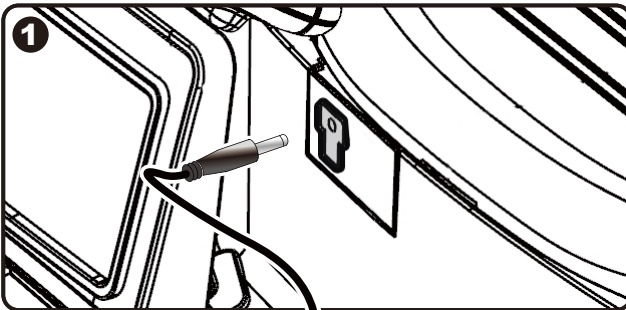

1. Plug the charger port into the input socket (the socket below the seat).
2. Plug the charger plug into a wall outlet. The battery will begin charging.

Problem	Possible Cause	Solution
Vehicle does not run	Battery low on power	Recharge battery.
	Thermal fuse has tripped	Reset fuse, see <Fuse>
	Battery connector or wires are loose	Check that the battery connectors are firmly plugged into each other. If wires are loose around the motor contact your distributor please.
	Battery is dead	Replace battery, contact your distributor please.
	Electrical system is damaged	Contact your distributor please.
	Motor is damaged	Contact your distributor please.
Vehicle does not run very long	Battery is under charged	Check that the battery connectors are firmly plugged into each other when recharging
	Battery is old	Replace battery, contact your distributor please.
Vehicle runs sluggishly	Battery low on power	Recharge battery, contact your distributor please.
	Battery is old	Replace battery, contact your distributor please.
	Vehicle is overload	Reduce weight on vehicle.
	Vehicle is being used in harsh conditions	Avoid using vehicle in harsh conditions, see <Safety>.
Vehicle needs a push to go forward	Poor contact of wires or connectors	Check that the battery connectors are firmly plugged into each other. If wires are loose around the motor, contact your distributor please.
	“Dead Spot” on motor	A dead spot means the electric power is not being delivered to the terminal connection and the vehicle needs repair. Contact your distributor please.
Difficult shifting from forward to reverse or vice-versa	Attempting to shift while the vehicle is motion	Completely stop the vehicle and shift, see <Use Your Ride-On>
Loud grinding or clicking noises coming from motor or gear box	Motor or gears are damaged	Contact your distributor please.
Battery will not recharge	Battery connector or adapter connector is loose	Check that the battery connectors are firmly plugged into each other.
	Charger not plugged in	Check that the battery charger is plugged into a working wall outlet.
	Charger is not working	Contact your distributor please.
Charger feels warm when recharging	This is normal and not a cause for concern	

Completely read through this manual and the troubleshooting guide table before calling. If you still need help resolving the problem **Contact your distributor please.**

UK

If you have any questions, please contact our customer care center.

Our contact details are below:



0044-800-240-4004



enquiries@mhstar.co.uk

IMPORTER ADDRESS:
MH STAR UK LTD
Unit 27, Perivale Park,
Horsenden lane South
Perivale, UB6 7RH
MADE IN CHINA