

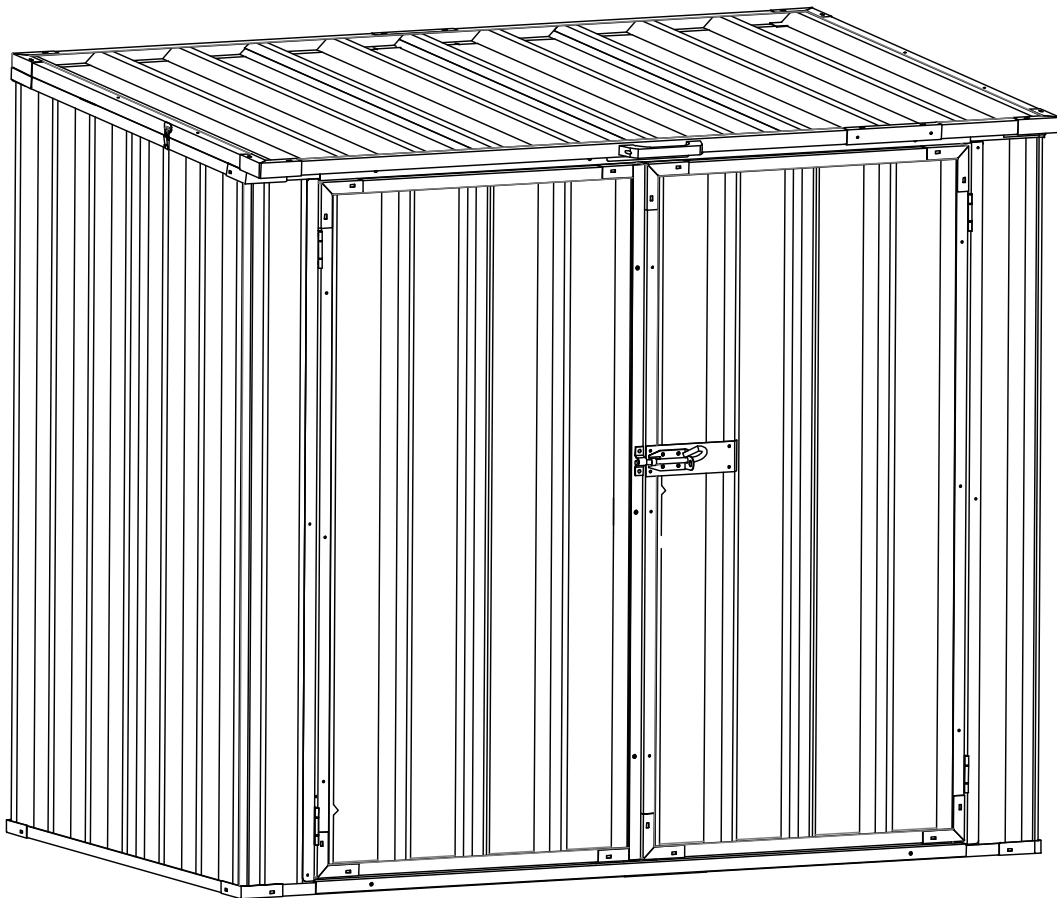

IN230400180V01_UK

845-682



EN_IMPORTANT, RETAIN FOR FUTURE REFERENCE: READ CAREFULLY.

FR_IMPORTANT: A LIRE ATTENTIVEMENT ET À CONSERVER POUR CONSULTATION ULTÉRIEURE.

ES_IMPORTANTE, LEA Y GUARDE PARA FUTURAS REFERENCIAS.

PT_IMPORTANTE, RETER PARA REFERÊNCIA FUTURA: LEIA ATENTAMENTE.

DE_WICHTIG! SORGFÄLTIG LESEN UND FÜR SPÄTER NACHSCHLAGEN AUFBEWAHREN.

IT_IMPORTANTE! CONSERVARE IL PRESENTE MANUALE PER FUTURO RIFERIMENTO E LEGGERLO ATTENTAMENTE.

EN

Dear customer,

Thank you for purchasing this product. So that your appliance serves you well, please read all the instructions in this user's manual. If you have any questions, please contact our customer care center, Our contact details are below:

FR

Cher client,

Nous vous remercions d'avoir acheté ce produit. Afin que vous puissiez profiter pleinement de votre appareil, veuillez lire toutes les instructions de ce manuel d'utilisation. Si vous avez la moindre question, veuillez contacter notre centre d'assistance à la clientèle, Nos coordonnées sont les suivantes:

DE

Sehr geehrter Kunde,

Vielen Dank, dass Sie dieses Produkt erworben haben. Damit Ihr Gerät Ihnen gute Dienste leistet, lesen Sie bitte alle Hinweise in diesem Benutzerhandbuch. Wenn Sie Fragen haben, wenden Sie sich bitte an unser Kundendienstzentrum, Unsere Kontaktdaten stehen unten:

ES

Queridos clientes,

Gracias por comprar este producto. Para que su electrodoméstico le sirva mejor, lea todas las instrucciones de este manual del usuario. Si tiene alguna pregunta, comuníquese con nuestro Centro de Atención al Cliente, Nuestros datos de contacto son los siguientes:

PT

Caros clientes,

Obrigado por adquirir este produto. Para que o seu aparelho o sirva melhor, leia todas as instruções deste manual do utilizador. Se tiver alguma dúvida, por favor contacte o nosso Centro de Atendimento ao Cliente, Os nossos dados de contacto são os seguintes:

IT

Caro Cliente,

Grazie per aver acquistato questo prodotto. Per servirti meglio con questo apparecchio ti prego di leggere tutte le istruzioni in presente manuale utente. In caso di dubbio, si prega di contattare il nostro centro assistenza clienti, I nostri dettagli di contatto sono di seguito:







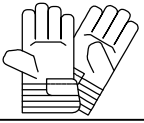

| Country |  Phone |  Email |
|---------|---|---|
| US | 001-877-644-9366 | customerservice@aosom.com |
| CA | 416-792-6088 | customerservice@aosom.ca |
| UK | 0044-800-240-4004 | enquiries@mhstar.co.uk |
| DE | 0049-0(40)-88307530 | service@aosom.de |
| FR | 0033-1-84166106 | aosom@mhfrance.fr |
| ES | 0034-931294512 | atencioncliente@aosom.es |
| PT | 0034-931294512 | info@aosom.pt |
| IT | 0039-0249471447 | clienti@aosom.it |

BEFORE YOU START

Follow these basic steps and assembly will be much easier!









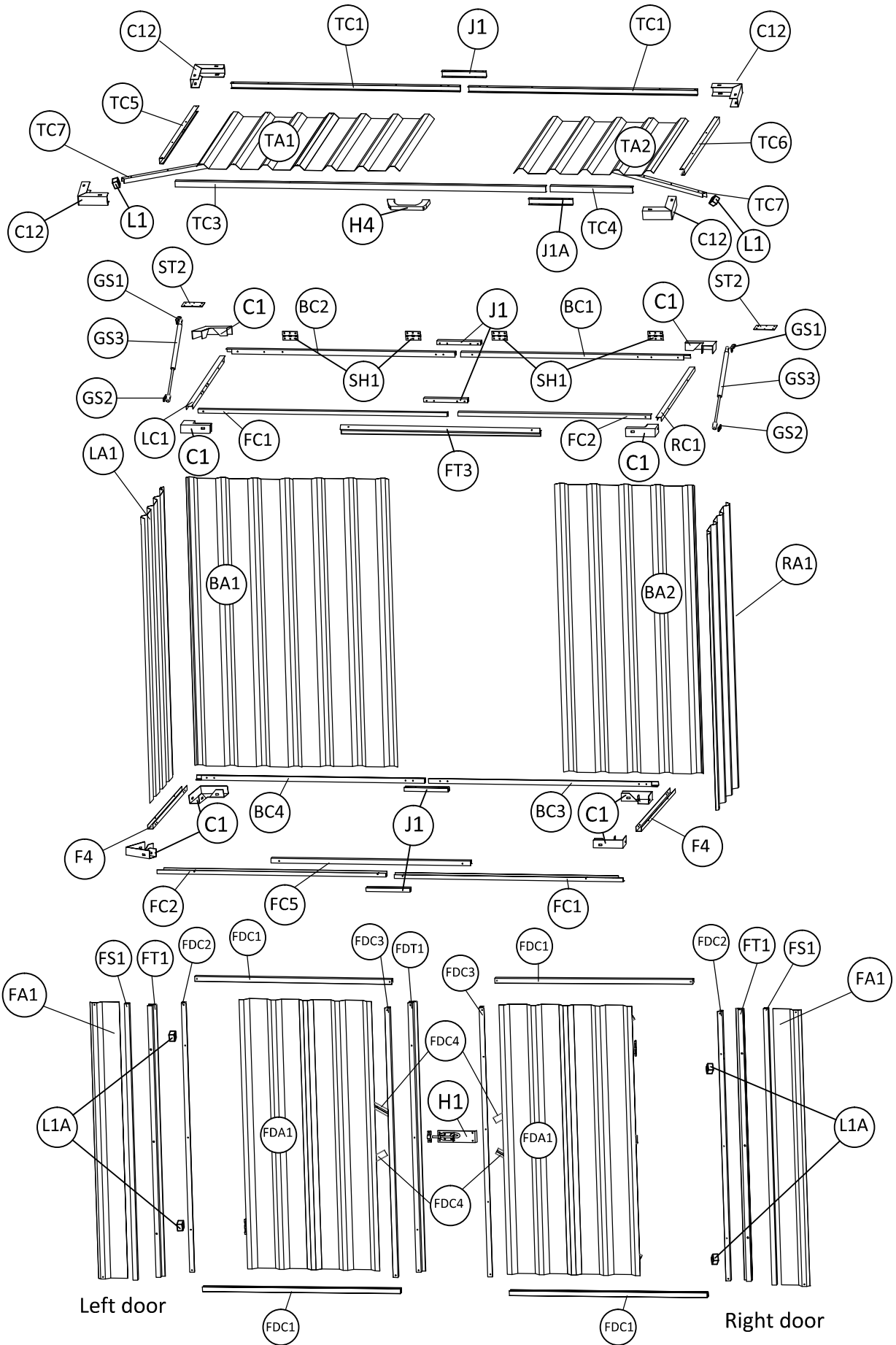



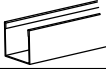
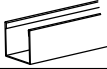
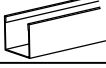
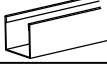

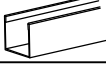
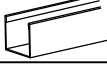

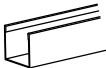
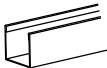
1. Prepare a suitable work space to allow access to all 4 sides.
2. A working surface or bench at around waist high will make assembly more comfortable.
3. Gather tools and safety gear.

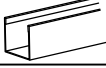
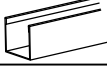

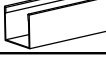



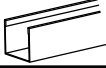
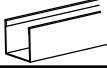



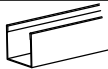
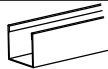
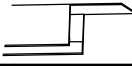







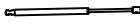

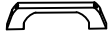







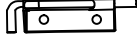

Items Required

| | | | | | |
|-------------|--|--|--|--|--|
| Safety Gear |  |  | |  |  |
| | Gloves | Safety Glasses | | Shoes | Spirit level |
| Tools |  |  |  |  |  |
| | Power drill | Screw drive | Pencil | Measure Tape | Rivet Gun |

4. From the carton, remove all channel pieces and other parts (not wall sheets) and lay them out within reach of your work surface or work bench.
5. Leave shed wall sheeting in the box until required.
6. Page 5 & 6 is an overview of the assembly processes. Start assembly at Page
7. **Follow each assembly page in order.**
An exploded drawing on page 2 may assist you as it shows where all the parts are positioned on the shed.
8. **Shed must be erected on level ground, use a spirit level.**

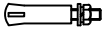

| Picture | Part No. | QTY | Check | Picture | Part No. | QTY | Check |
|---|----------|-----|-------|---|----------|-----|-------|
| Rear wall | | | | | | | |
|  | BA1 | 1 | |  | BA2 | 1 | |
|  | BC1 | 1 | |  | BC2 | 1 | |
|  | BC3 | 1 | |  | BC4 | 1 | |
| Left Wall | | | | | | | |
|  | LA1 | 1 | | | | | |
|  | LC1 | 1 | |  | F4 | 1 | |
| Right Wall | | | | | | | |
|  | RA1 | 1 | | | | | |
|  | RC1 | 1 | |  | F4 | 1 | |
| Roof Door | | | | | | | |
|  | TA1 | 1 | |  | TA2 | 1 | |
|  | TC1 | 2 | |  | TC3 | 1 | |
|  | TC4 | 1 | |  | TC5 | 1 | |
|  | TC6 | 1 | |  | TC7 | 2 | |
| Front Wall | | | | | | | |
|  | FA1 | 2 | |  | FDA1 | 2 | |
|  | FC1 | 2 | |  | FC2 | 2 | |
|  | FC5 | 1 | |  | FDC1 | 4 | |

| Picture | Part No. | QTY | Check | Picture | Part No. | QTY | Check |
|---|----------|-----|-------|--|----------|-----------------|-------|
|  | FDC2 | 2 | |  | FDC3 | 2 | |
|  | FDC4 | 4 | |  | FT3 | 1 | |
|  | FDT1 | 1 | |  | FT1 | 2 | |
|  | FS1 | 2 | | | | | |
| Other Parts | | | | | | | |
|  | ST2 | 2 | |  | GS1 | 2 | |
|  | GS2 | 2 | |  | GS3 | 2 | |
|  | C1 | 8 | |  | H4 | 1 | |
|  | L1 | 4 | |  | L1A | 8 | |
|  | H8 | 2 | |  | H1B | 1 | |
|  | J1 | 5 | |  | J1A | 1 | |
|  | H1 | 1 | |  | H3 | 1 | |
|  | H2 | 1 | |  | SH1 | 8 | |
|  | C12 | 12 | | | | | |
|  Drill | | 1 | |  Gloves | | 1 | |
|  | S2 | 2 | |  | S3 | 92 +2(spare) | |
|  | S5 | 26 | |  | S7 | 84 +2(spare) | |
|  | L3 | 34 | |  | S11 | 4 | |
|  | C7 | 4 | |  | | 3 | |

ASSEMBLY OVERVIEW

This shed is a DIY flat pack kit and is designed that way to minimise shipping and production costs making the shed more affordable. The process of building the shed is firstly to assemble each wall and roof in turn. When this is completed the shed will be erected and fixed to a concrete slab. Alternately if built on a level earth floor and attached to a wall of fence.

HOW TO ATTACH CHANNEL PIECES TO WALL SHEETS

Channels are attached to wall sheets using “Click-Well” technology where channel pieces click on to the end of wall sheets.

Position U channel over one end of the joined sheets, working from one end push channel down to clip onto sheets, continue to the end of the channel pushing as you go. (Use the heel of your hand or a rubber mallet, see video)

PUSH

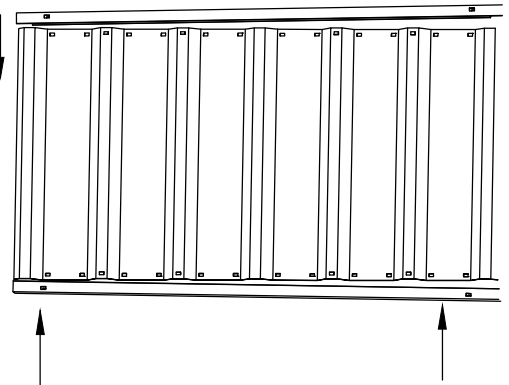

If you need to remove U channels from the panels, pull the channel along the panel from opposing ends. You may need someone to help with this.

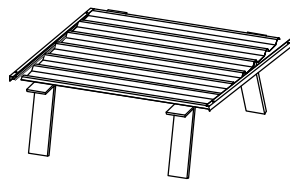

A raised platform will make assembly easier.

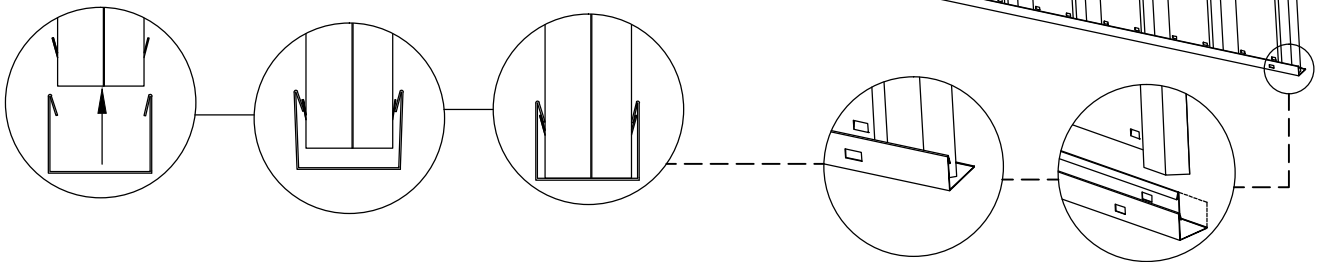
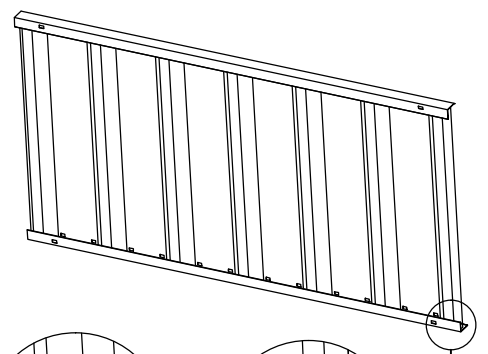

HOW TO JOIN CHANNELS (where needed)

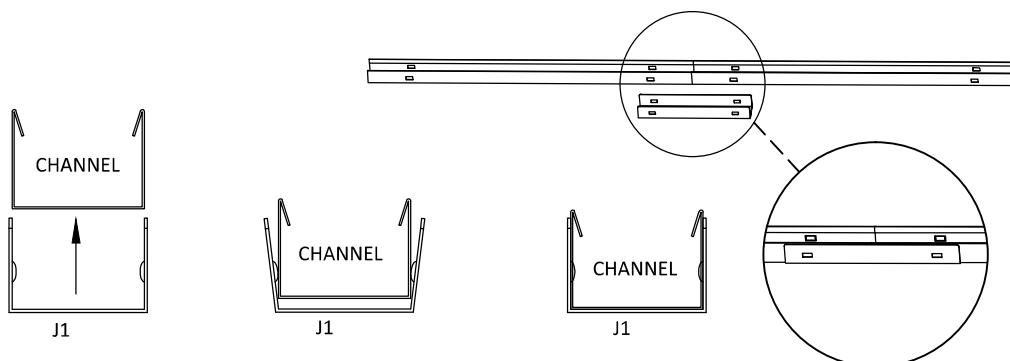

ASSEMBLY OVERVIEW

Roof Door

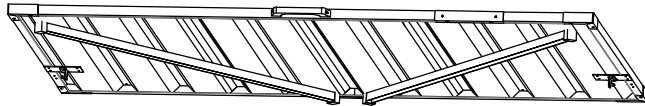

Left Wall

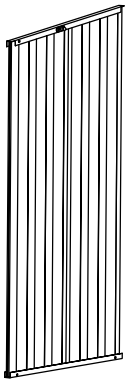

Rear wall

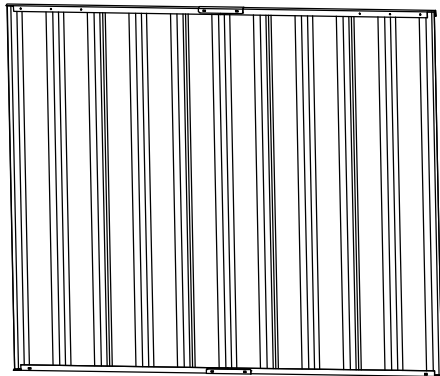



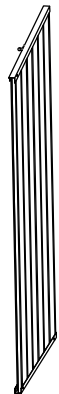



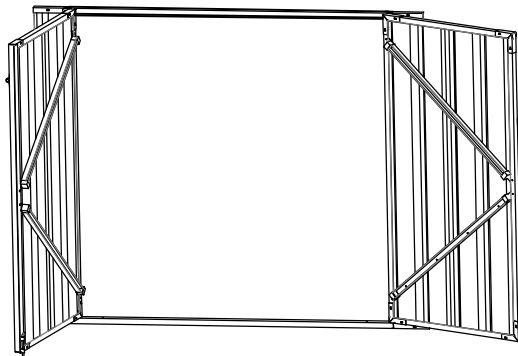

Right Wall



Front Wall



PANEL ASSEMBLY STEP 1 REAR WALL

| | | | | | | | | | | | |
|---|-----|---|---|-----|---|---|-----|---|---|----|---|
|  | BA1 | 1 |  | BA2 | 1 |  | BC4 | 1 |  | J1 | 2 |
|  | BC1 | 1 |  | BC2 | 1 |  | BC3 | 1 |  | | |

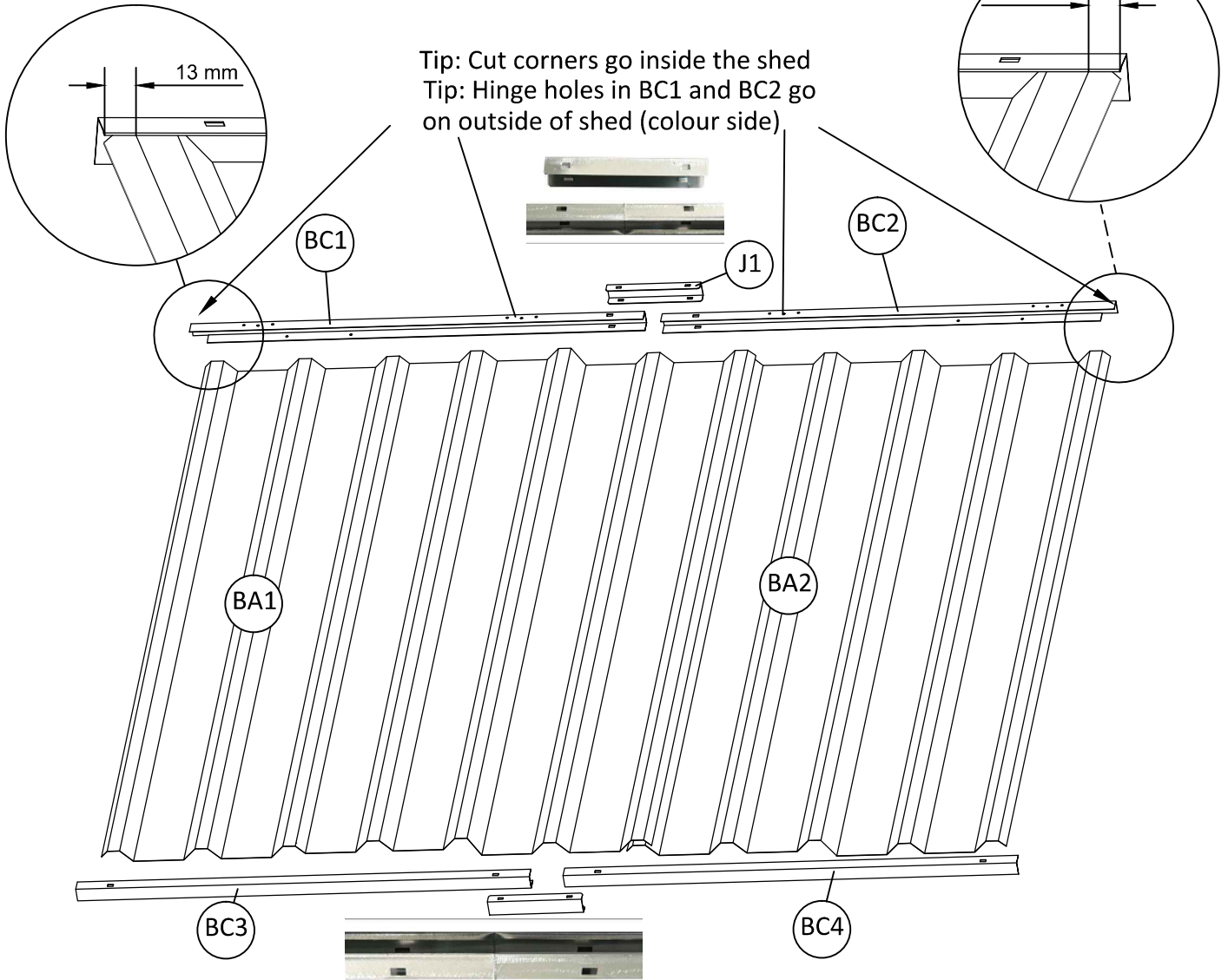

Tip: Cut corners go inside the shed
 Tip: Hinge holes in BC1 and BC2 go on outside of shed (colour side)

Where sheets are joined overlap with 1 raised rib.





Where the top and bottom U channels meet ensure they meet at the centre of the wall panel.

J1







PANEL ASSEMBLY STEP 2 LEFT & RIGHT WALLS

Left Wall Assembly







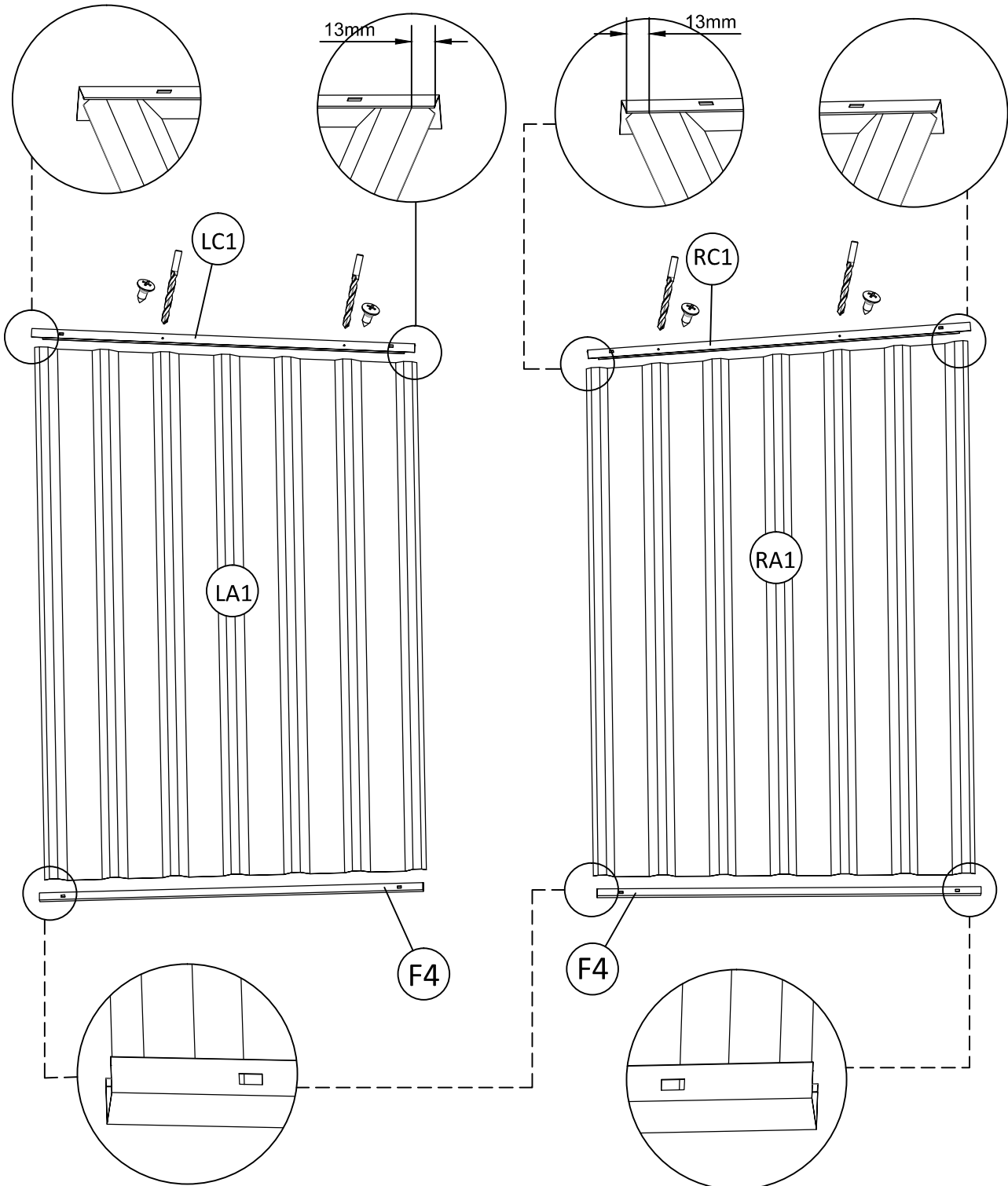



| | | | | | |
|---|-----|---|---|-----|---|
|  | LA1 | 1 |  | LC1 | 1 |
|  | F4 | 1 |  | S3 | 2 |

Right Wall Assembly

| | | | | | |
|---|-----|---|---|-----|---|
|  | RA1 | 1 |  | RC1 | 1 |
|  | F4 | 1 |  | S3 | 2 |



PANEL ASSEMBLY STEP 3 ROOF DOOR

| | | | | | | | | | | | |
|---|-----|---|---|-----|---|---|-----|---|---|-----|---|
|  | TA1 | 1 |  | TA2 | 1 |  | TC1 | 2 |  | TC3 | 1 |
|  | TC4 | 1 |  | TC5 | 1 |  | TC6 | 1 |  | S3 | 6 |
|  | C12 | 4 |  | J1 | 1 |  | J1A | 1 | | | |

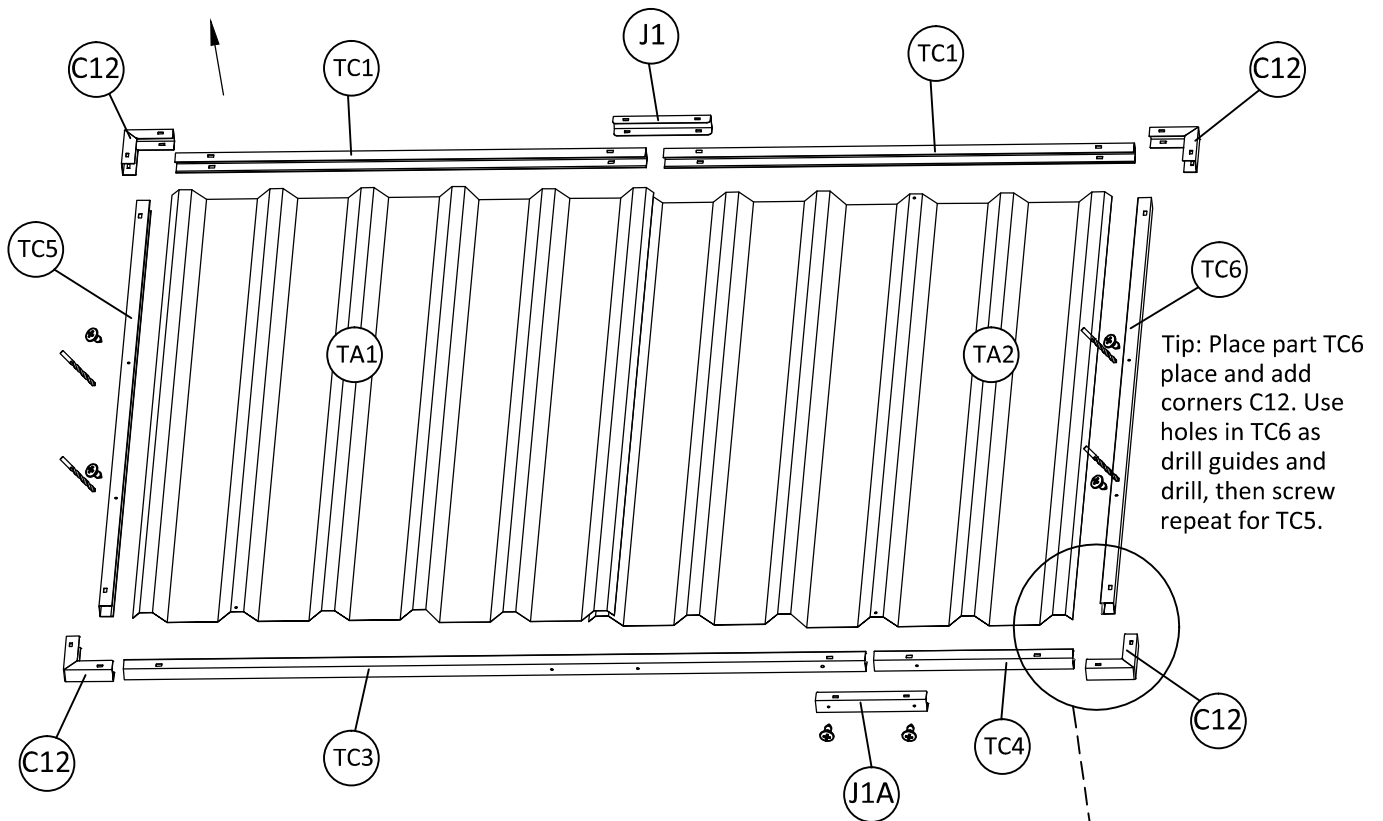
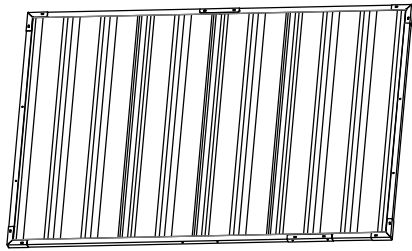



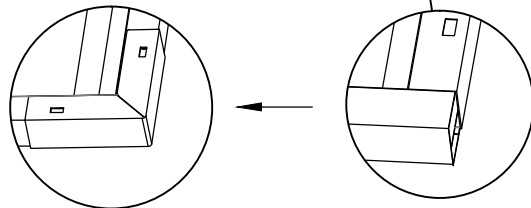

TIP: Place part TC5 on sheet. Add C12 corners over all channels, then drill holes and screw TC5 to sheet.

Place part TC6 on sheet. Add C12 corners over all channels, then drill holes and screw TC6 to sheet.



PANEL ASSEMBLY STEP 4 ROOF DOOR

| | | | | | | | | |
|---|-----|---|---|-----|---|---|----|---|
|  | GS1 | 2 |  | S2 | 2 |  | H4 | 1 |
|  | S7 | 8 |  | ST2 | 2 | | | |

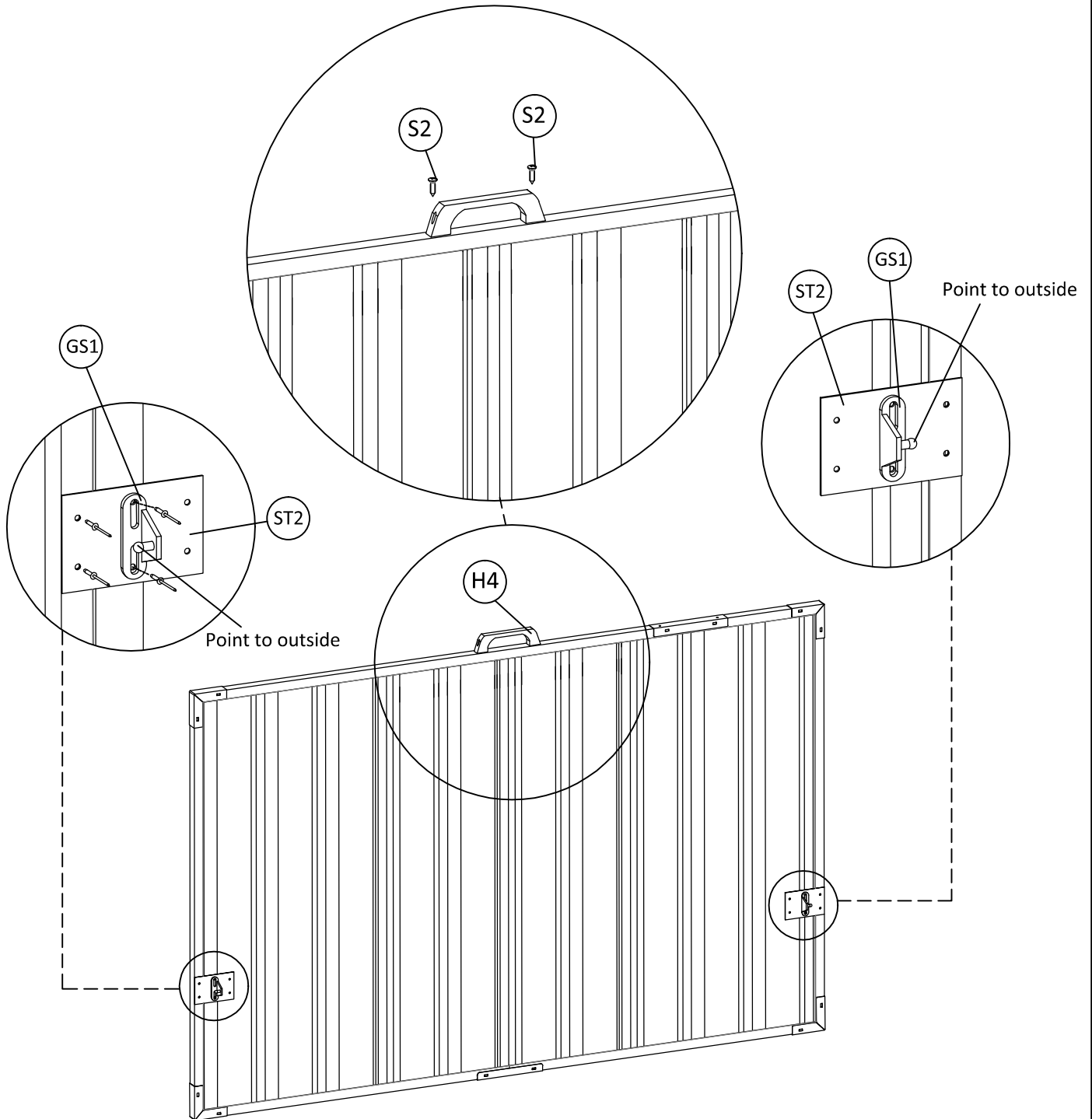

PANEL ASSEMBLY STEP 5 ROOF DOOR

To ensure the roof door closes correctly please refer to the diagram below for placement measurements.

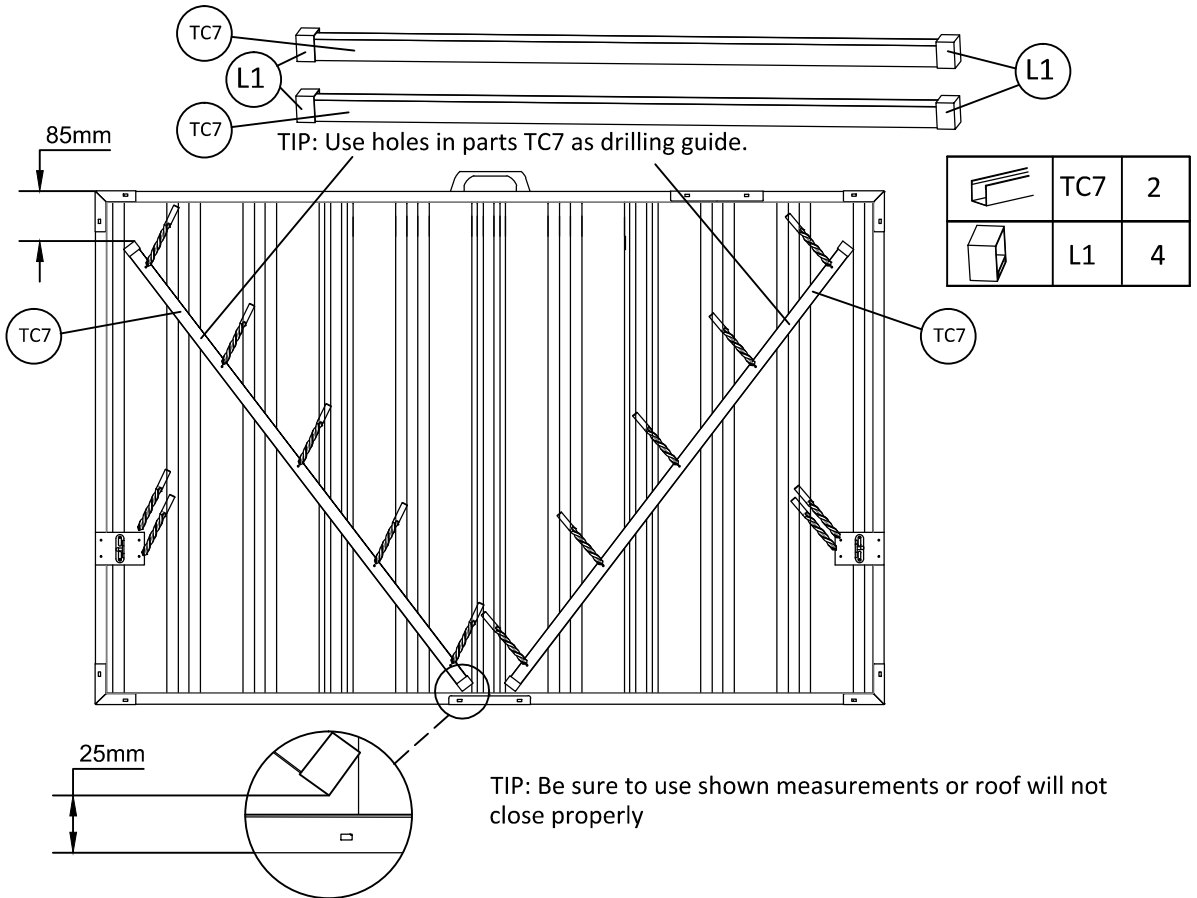



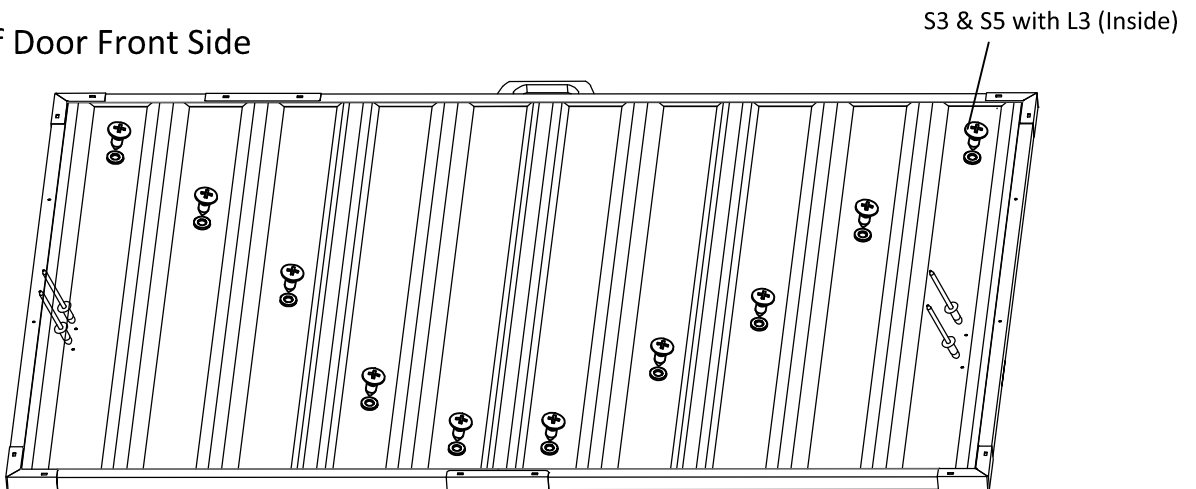

| | | | | | | | | | | | |
|--|----|----|--|----|----|--|----|----|--|----|---|
| | S3 | 10 | | S5 | 10 | | L3 | 10 | | S7 | 4 |
|--|----|----|--|----|----|--|----|----|--|----|---|

Roof Door Front Side



PANEL ASSEMBLY STEP 6 FRONT WALL

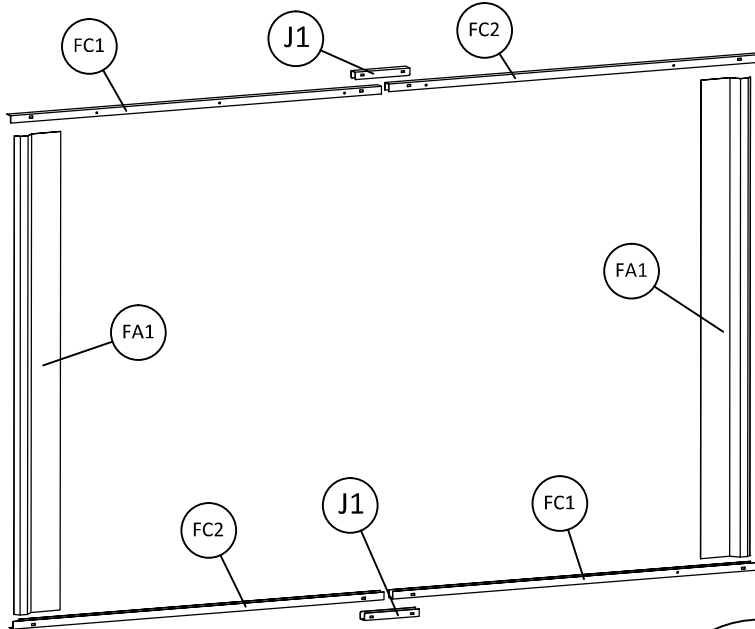

| | | | | | | | | | | | |
|---|-----|---|---|-----|---|---|-----|---|---|----|---|
|  | FA1 | 2 |  | FC1 | 2 |  | FC2 | 2 |  | J1 | 2 |
|---|-----|---|---|-----|---|---|-----|---|---|----|---|



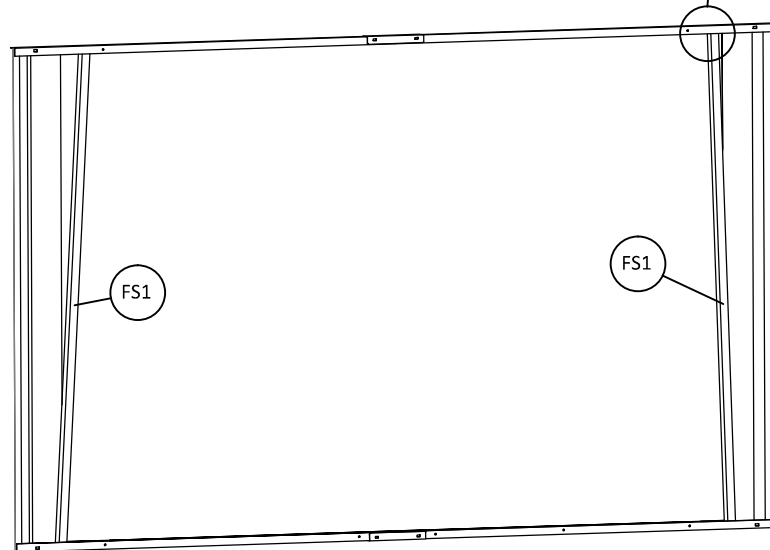
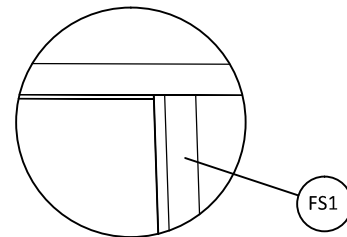

| | | |
|---|-----|---|
|  | FS1 | 2 |
|---|-----|---|

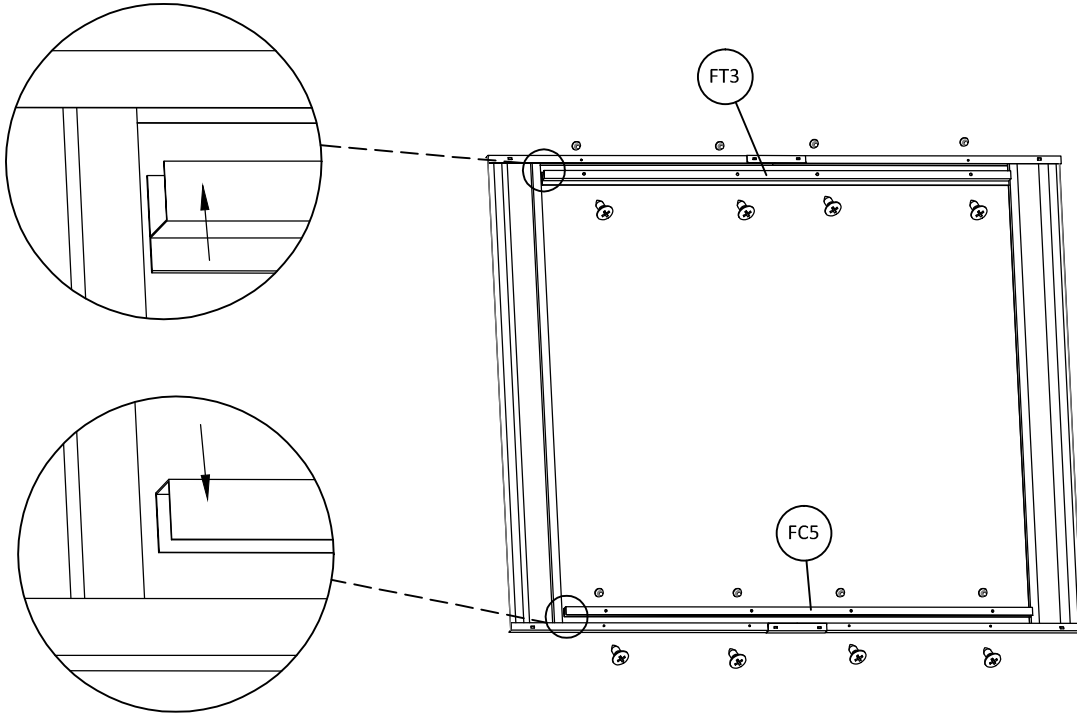

PANEL ASSEMBLY STEP 7 FRONT WALL

| | | | | | | | | |
|---|-----|---|---|----|----|--|-----|---|
|  | FT3 | 1 |  | S3 | 16 |  | FC5 | 1 |
|---|-----|---|---|----|----|--|-----|---|



| | | | | | |
|---|-----|---|---|----|----|
|  | FT1 | 2 |  | S7 | 12 |
|---|-----|---|---|----|----|

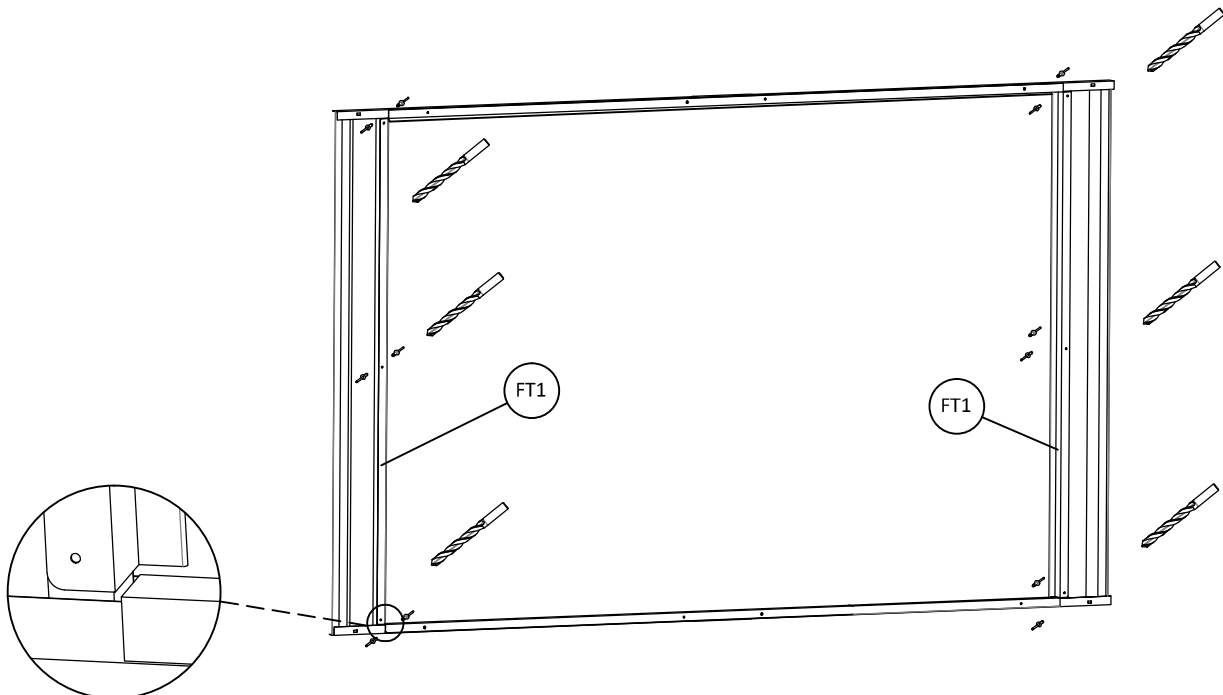

PANEL ASSEMBLY STEP 8 LEFT FRONT DOOR

| | | | | | |
|--|------|---|--|------|---|
| | FDA1 | 1 | | FDC1 | 2 |
| | FDC2 | 1 | | FDC3 | 1 |
| | FDT1 | 1 | | S3 | 6 |
| | C12 | 4 | | | |

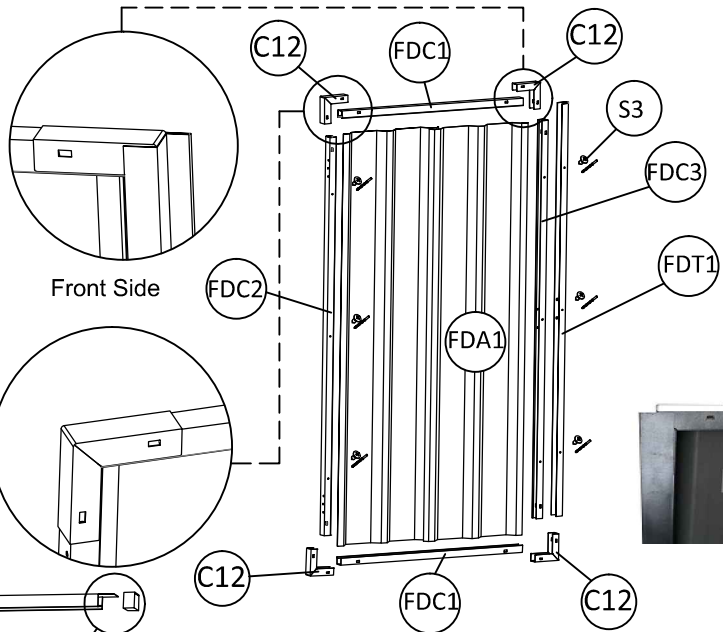

Door bracing

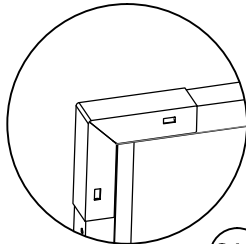

| | | | | | |
|--|------|---|--|-----|---|
| | FDC4 | 2 | | L1A | 4 |
| | S3 | 8 | | H3 | 1 |
| | H2 | 1 | | | |

TIP: Use holes in parts FDC4 as drilling guide.

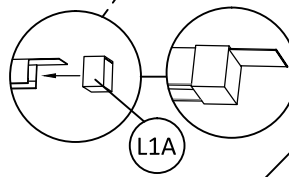



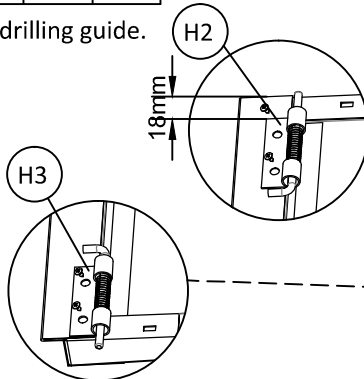
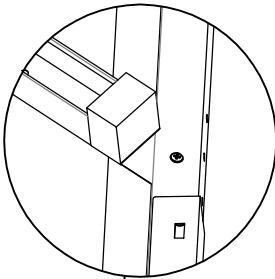
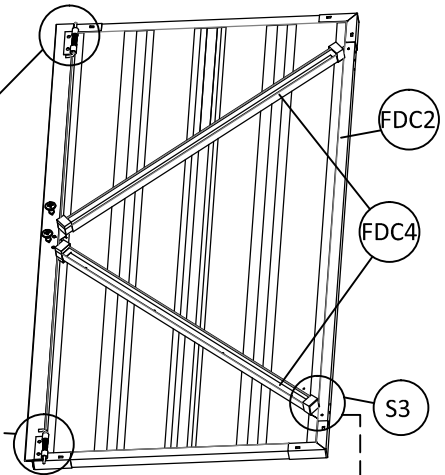

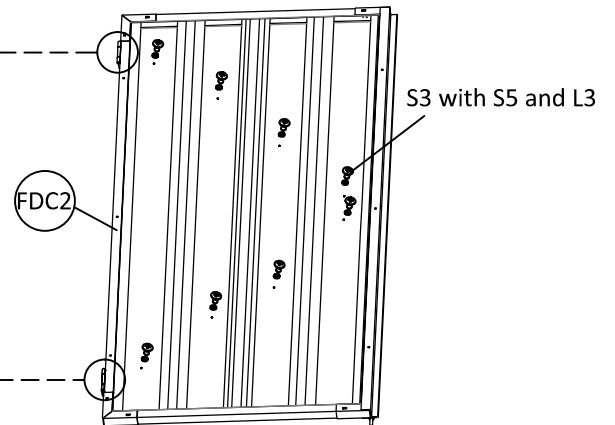
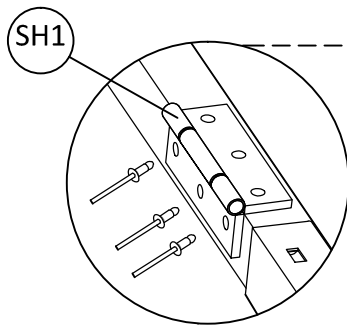

Rear Side



| | | | | | |
|--|-----|---|--|--|--|
| | SH1 | 2 | | | |
| | S3 | 8 | | | |
| | S5 | 8 | | | |
| | S7 | 6 | | | |
| | L3 | 8 | | | |



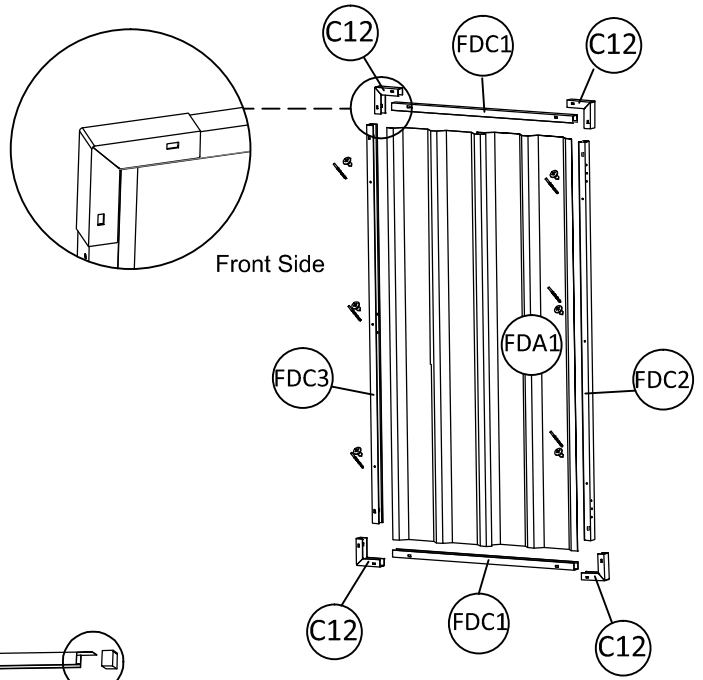

PANEL ASSEMBLY STEP 9 RIGHT FRONT DOOR

| | | | | | |
|---|------|---|---|------|---|
|  | FDA1 | 1 |  | FDC1 | 2 |
|  | FDC2 | 1 |  | FDC3 | 1 |
|  | S3 | 6 |  | C12 | 4 |



Door bracing





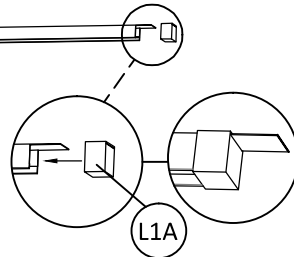

| | | | | | |
|---|------|---|--|-----|---|
|  | FDC4 | 2 |  | L1A | 4 |
|  | S3 | 4 | | | |

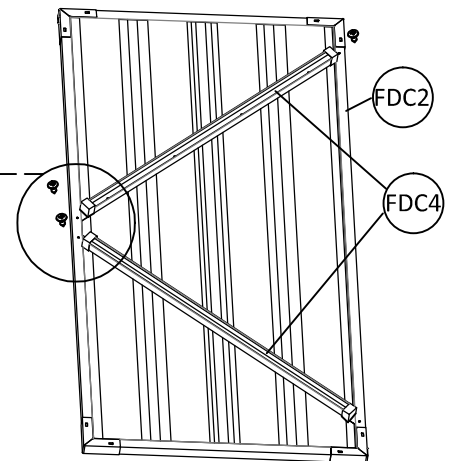
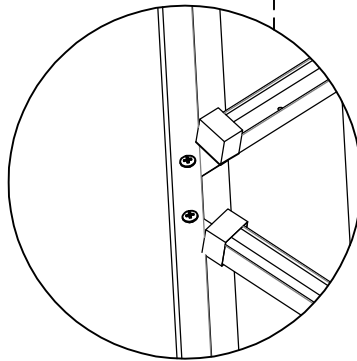

TIP: Use holes in parts FDC4 as drilling guide.





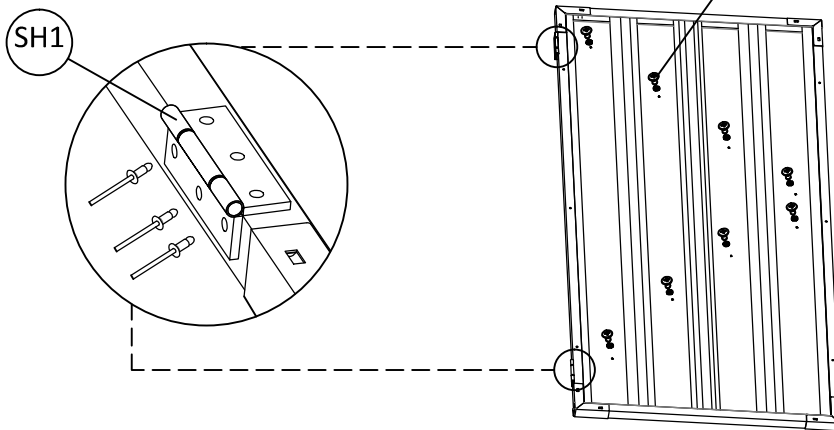

S3 with S5 and L3

| | | | | | |
|---|-----|---|--|--|--|
|  | SH1 | 2 | | | |
|  | S3 | 8 | | | |
|  | S5 | 8 | | | |
|  | S7 | 6 | | | |
|  | L3 | 8 | | | |



SHED ASSEMBLY STEP 1 JOINING WALLS

| | | | | | | | | | | | |
|---|-----|---|---|----|----|---|----|---|---|----|---|
|  | GS2 | 2 |  | S3 | 16 |  | C1 | 8 |  | L3 | 8 |
|---|-----|---|---|----|----|---|----|---|---|----|---|

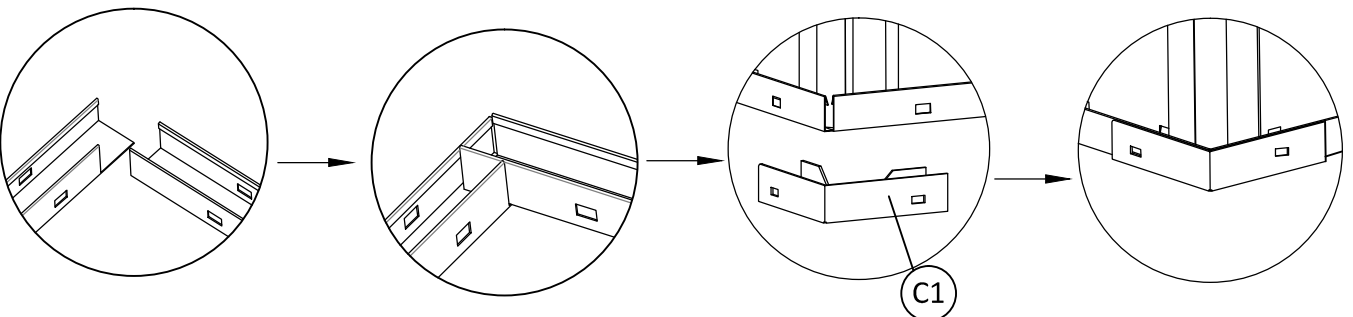
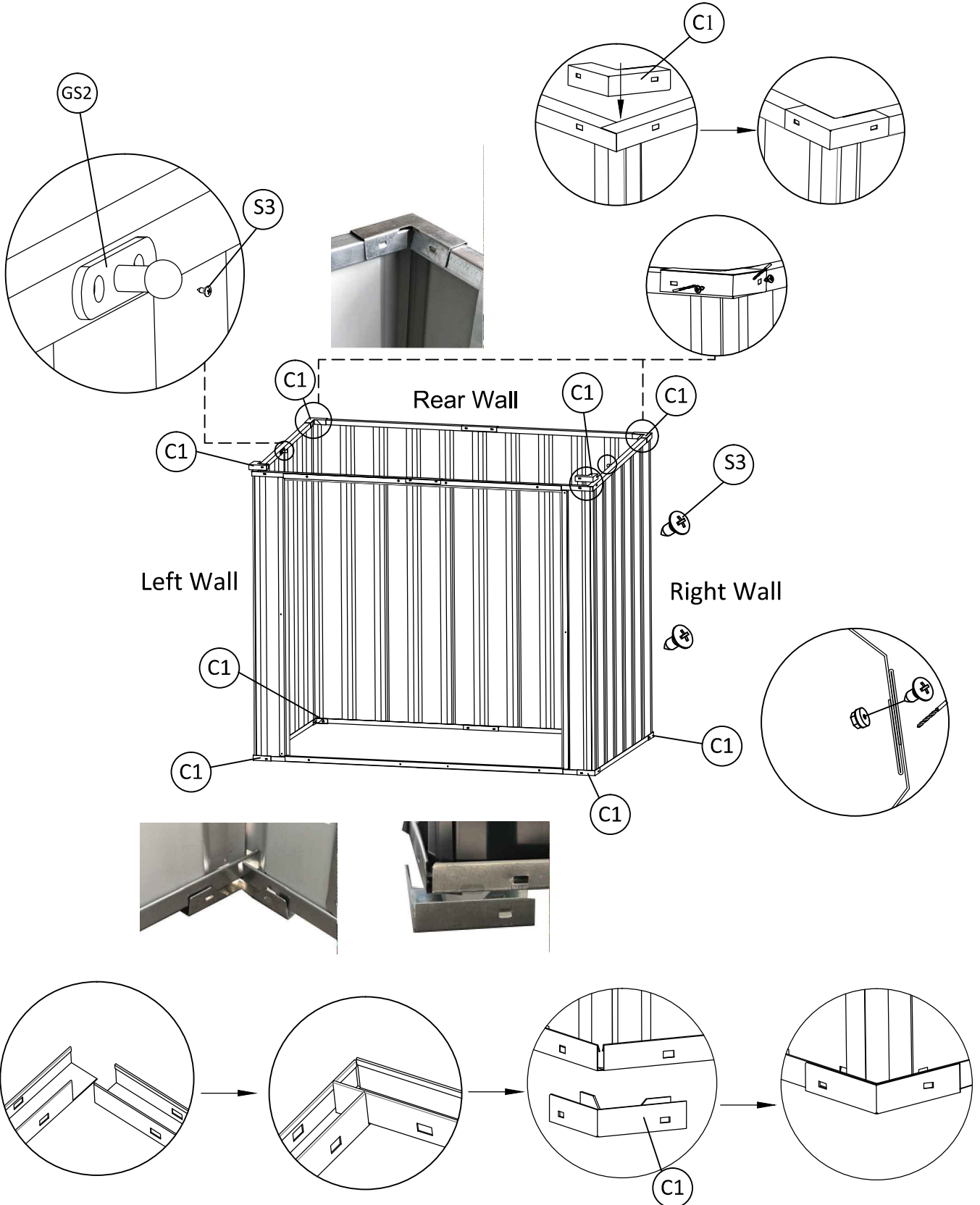

SHED ASSEMBLY STEP 2 ADDING ROOF

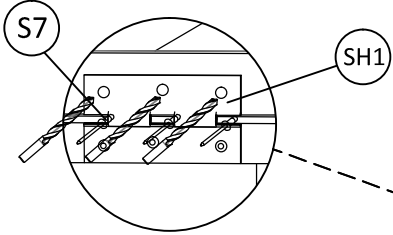

| | | | | | |
|---|----|----|--|-----|---|
|  | S7 | 24 |  | SH1 | 4 |
|---|----|----|--|-----|---|

Measure the position of hinges as shown, mark and drill holes to suit.

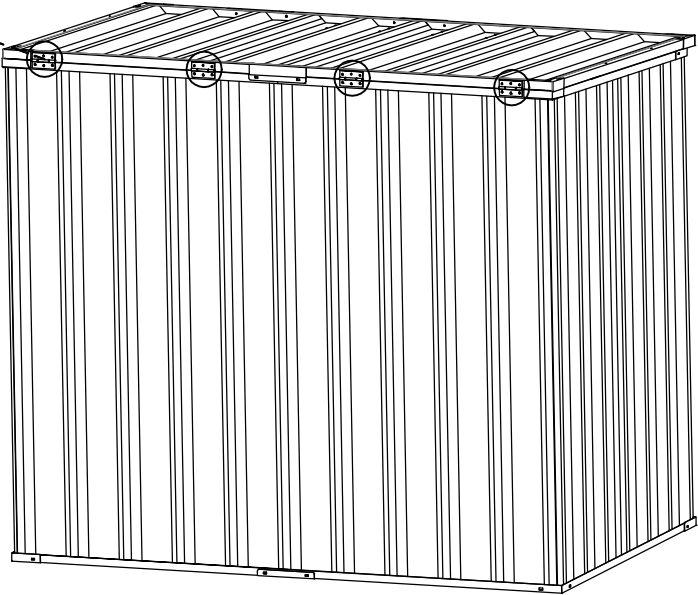

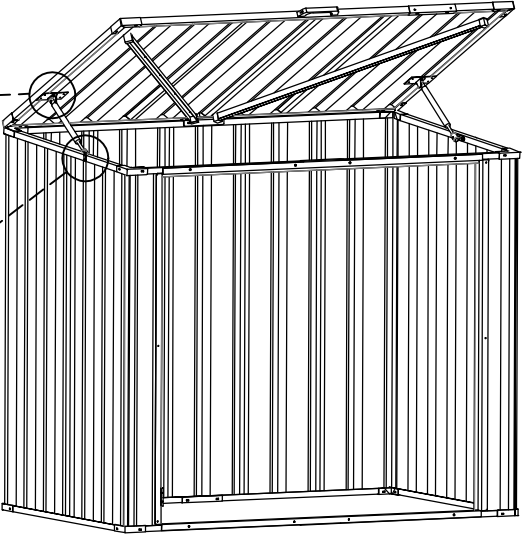
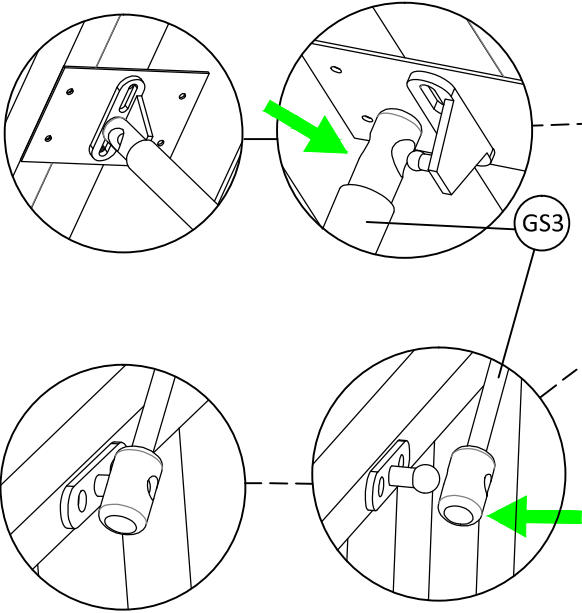

Positioning of Gas Struts (GS1, GS2 & GS3)

| | | |
|---|-----|---|
|  | GS3 | 2 |
|---|-----|---|



SHED ASSEMBLY STEP 3 ANCHORING SHED

| | | |
|---|-----|---|
|  | C7 | 4 |
|  | S11 | 4 |

The shed is now free standing. It is critical at this stage to ensure the shed is levelled. Then measure the diagonal distance and make sure the four side walls are squared to 90 degrees.

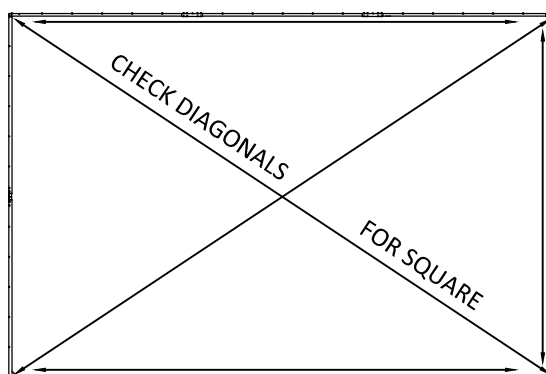

Use anchor kit (C7 & S11) when fixing to a concrete base.

Fastening the anchor kit onto a concrete pad

1. Mark the spot of the anchor clamps on the ground.
2. Use 12mm concrete drill bit and drill holes 60mm deep.
3. Tap concrete fixing bolts into the hole, place anchor clamps, add washer and nut and fasten.

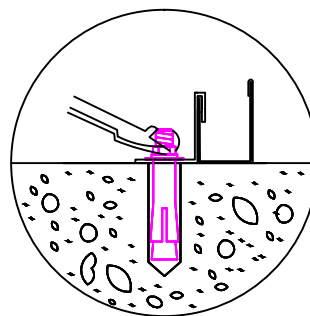
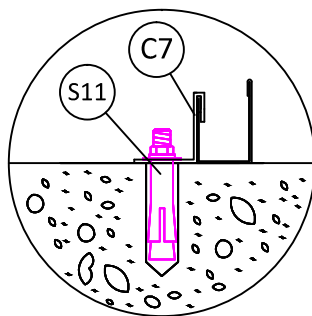
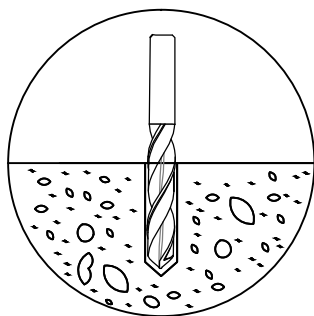
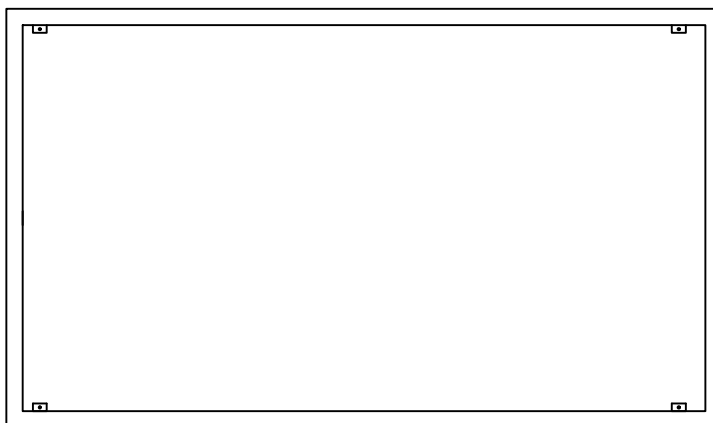



SHED ASSEMBLY STEP 4 FIX HANG DOORS

Position a door to allow correct opening and closing, mark and drill holes for hinges. Attach Door and repeat for second door.
TIP: Mark and drill 1 hinge hole and fix and test then drill other holes.

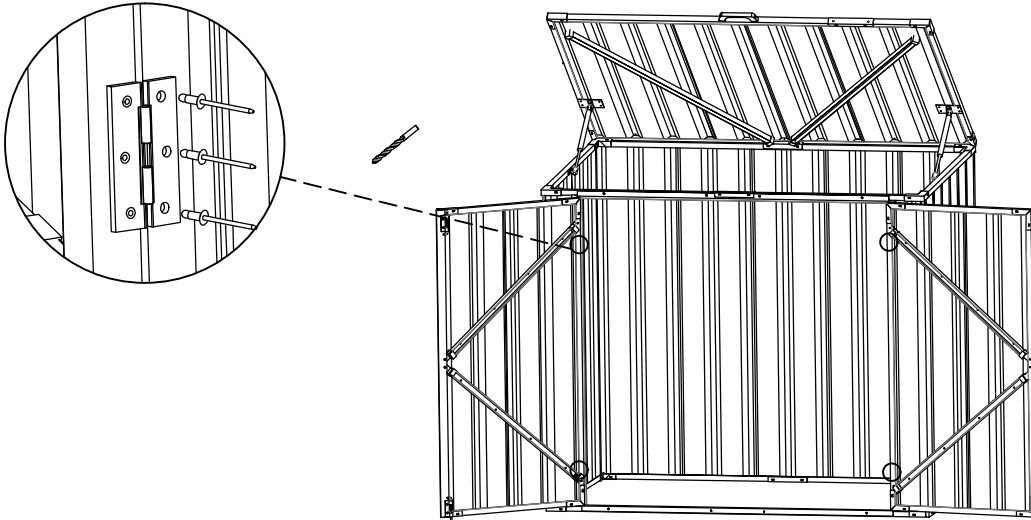
| | | |
|---|----|----|
|  | S7 | 12 |
|---|----|----|



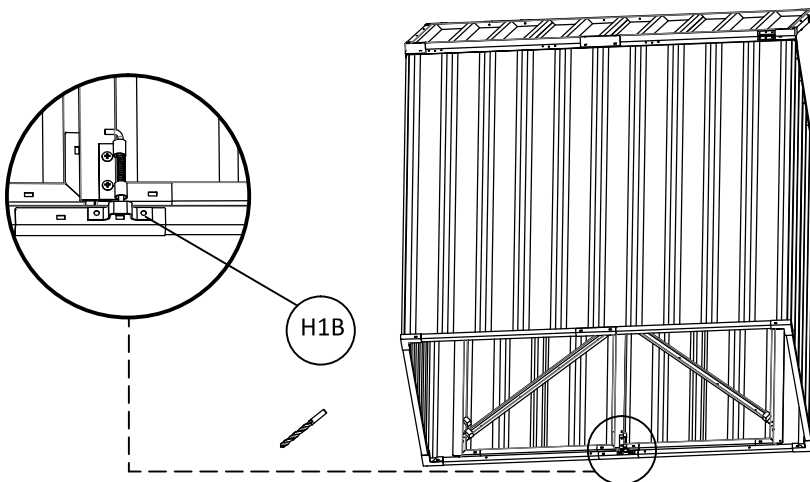

TIP: Shed base must be level for correct door closure, check base is with spirit level before adjusting doors

| | | | | | |
|---|-----|---|---|----|---|
|  | H1B | 1 |  | S3 | 2 |
|---|-----|---|---|----|---|

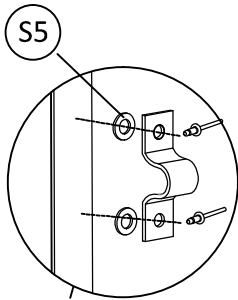

SHED ASSEMBLY STEP 5 ADD HARDWARE



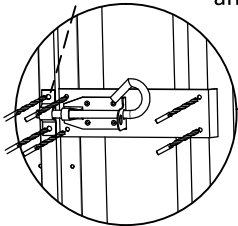

| | | | | | |
|---|----|---|---|----|---|
|  | H1 | 1 |  | S7 | 6 |
|---|----|---|---|----|---|

It is easy to use, please add some S5 under H1.

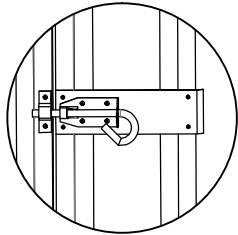
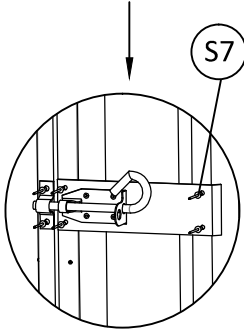
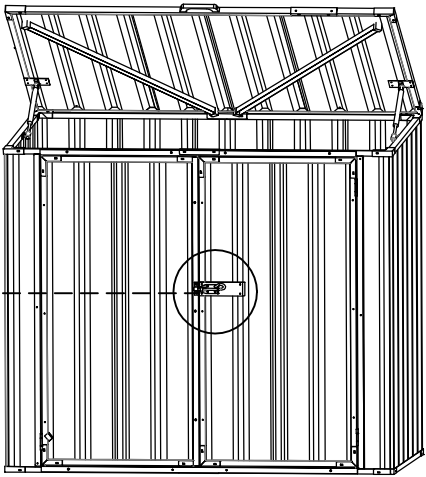

Install the latch in position as shown and fix with rivets.



| | | | | | |
|---|----|---|---|----|---|
|  | H8 | 2 |  | S7 | 8 |
|---|----|---|---|----|---|

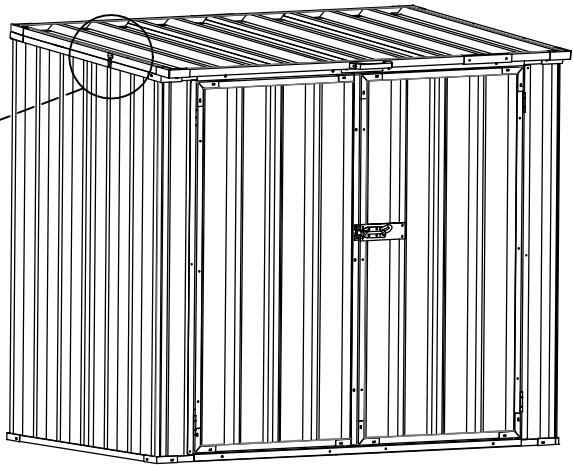
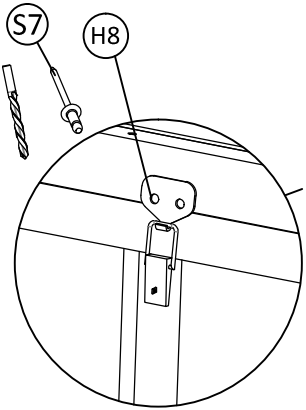

US

Imported by Aosom LLC
27150 SW Kinsman Rd Wilsonville, OR 97070 USA
MADE IN CHINA

CA

Imported by Aosom Canada Inc.
7270 Woodbine Avenue, Unit 307, Markham, Ontario Canada
L3R 4B9
MADE IN CHINA

Importé par Aosom Canada Inc.
7270 Woodbine Avenue, unité 307, Markham, Ontario Canada
L3R 4B9
Fabriqué en Chine

UK

IMPORTER ADDRESS:
MH STAR UK LTD
Unit 27, Perivale Park,
Horsenden lane South
Perivale, UB6 7RH
MADE IN CHINA

FR

ADRESSE D'IMPORTATION:
MH FRANCE
2 Rue Maurice Hartmann
92130 Issy Les Moulineaux
France
FABRIQUÉ EN CHINE



Adresses sur quefairedemesdechets.fr

ES

IMPORTADOR:
SPANISH AOSOM, S.L.
C/ROC GROS, Nº15.08550, ELS HOSTALET DE BALENYÀ, SPAIN.
B66295775
WWW.AOSOM.ES
ATENCIONCLIENTE@AOSOM.ES
TEL: 931294512
HECHO EN CHINA

PT

SPANISH AOSOM, S.L
C.ROC GROS N.15, 08550. ELS HOSTALET DE BALENYÀ
TEL: 931294512 (SEG-SEX DAS 7:30H ÀS 16:30H)
INFO@AOSOM.PT
WWW.AOSOM.PT

DE

ADRESSE DES IMPORTEURS:
MH Handel GmbH
Wendenstraße 309
D-20537 Hamburg
Germany
IN CHINA HERGESTELLT

IT

IMPORTATO DA:
AOSOM Italy srl
Centro Direzionale Milanofiori
Strada 1 Palazzo F1
20057 Assago (MI)
P.I.: 08567220960
FATTO IN CINA