



IN230600006V01_UK_FR_ES_IT

A91-092

EN



IMPORTANT, RETAIN FOR FUTURE REFERENCE: READ CAREFULLY

ASSEMBLY INSTRUCTION

Installation

Step 1: Open package to confirm product components

Accessories

A Foot tube (2pcs)



B Main Frame (including tube cover)



C Upper Tube (2pcs)



D Elbow pad one pair



E Bottom tube cover (4pcs)



F Supporting Tube



G Gym Bar (including hand gloves)



H Base Connection



I Hand Gloves (4pcs)



J Main Frame Connection Tube



K Screw M8x65mm(22pcs)



M Wrench 13-17 (2pcs)



N Screw M8x75 (2pcs)



O screw 8x60 (2pcs)



P Screw Nut M8 (2pcs)



Q Screw M8x55 (4pcs)



R Back Set



T Leg Tube

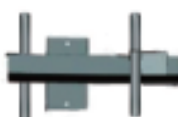

U Sit Up Bench (Back Set)



v Plastic gasket



W Bolt 8x66(2pcs)



X Screw M10x20mm(2pcs)



Y Screw (1pcs)



Z Screw M8x55 (1pcs)



Step 2: Assembly 4 foot covers

Accessories:

E Foot Cover (4pcs)



A Foot Tube 2 pcs



Use 4 foot covers to insert into the foot tube

Step 3: Assembly the bottom connection tube

Accessories:

H Bottom Connection Tube



K Screw M8x65mm(4pcs)

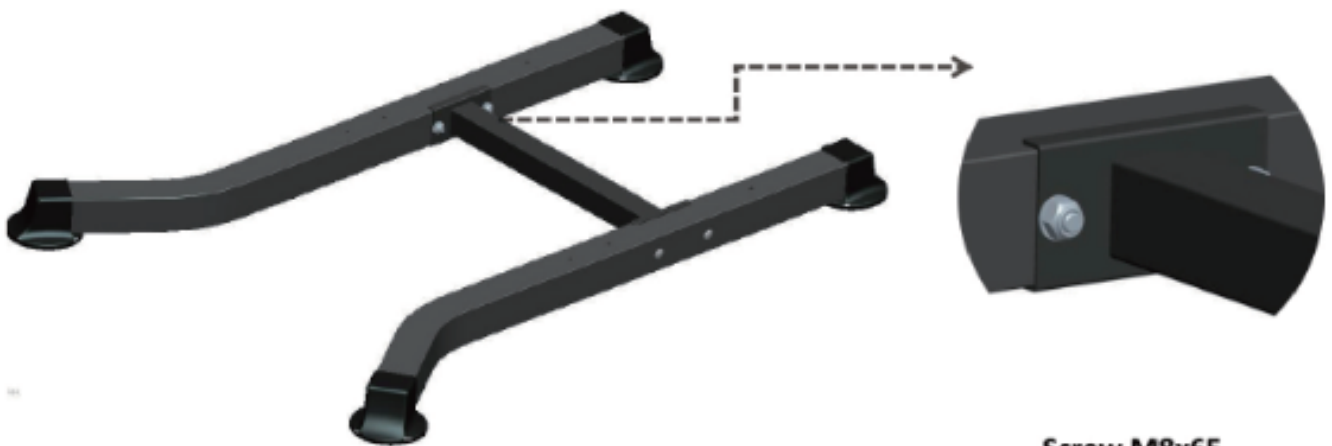

Screw M8x65

Step 4: Assembly Main Frame

Accessories:

B Main Frame



F Supporting Tube



K Screw M8x65mm(12pcs)

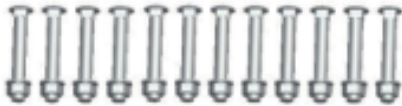

Step 5: Assembly Main Frame Connection Tube with bench connection tube

K Screw M8x65mm(4pcs)



J Main Frame Connection



**Screw M8x65mm
(Outside use bigger gasket)**

Accessories:

R Sit up bench Tube



Step 6: Assembly Elbow pad

Accessories:

Q Screw M8x55 (4pcs)

D Elbow pad one pair



Step 7: Assembly upper tube and gym bar

Accessories:

C Upper Tube (2pcs)

G Gym Bar(with hand gloves)

N Screw M8x75 (2pcs)



Step 8: Adjust suitable angles and heights

Accessories:

O Screw 8x60 (2pcs)



P Screw Nut M8 (2pcs)

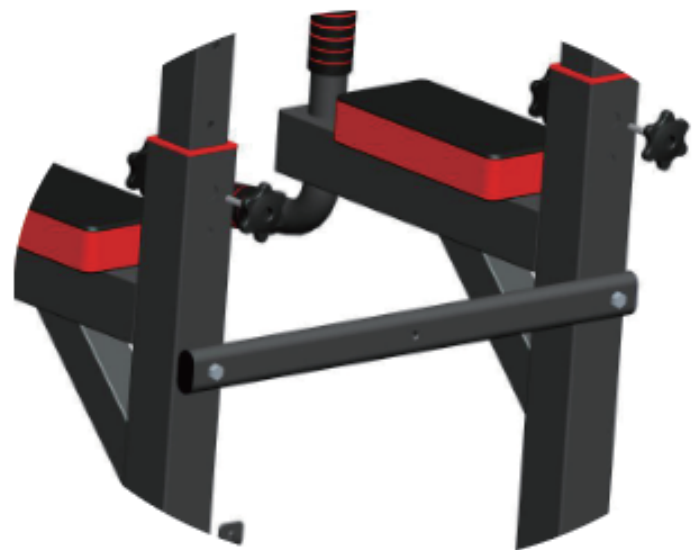

Use Screw 8x60 Fix
Totally 7 adjustment

Installation complete without bench (See pic)

Step 9: Assembly sit up bench (Using)

V Plastic Gasket **X** Screw M10x20mm(2pcs)

U Sit Up bench (Back set)

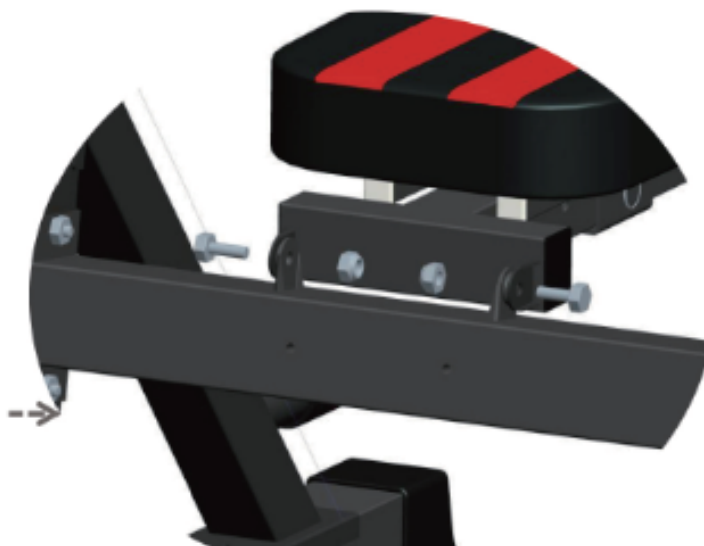

Use screw M10X20 add gasket in the middle

Step 10: Assembly Foot tube

K Screw M8x65mm+big gasket dia30(2pcs)



T foot tube

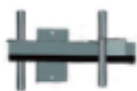

Q Screw M8x55 (1pcs)



W Bolt 8x66(1pcs)



I Hand Gloves (4pcs)

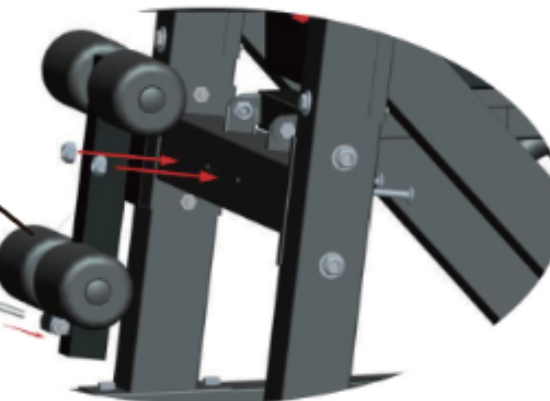

Use Screw M8x65mm (add 2 big gasket)

Bolt adjust the sit up bench foldable or not



Step 11: Folding storage:

Accessories:

W Bolt 8x66(1pcs)



Y Screw (1pcs)

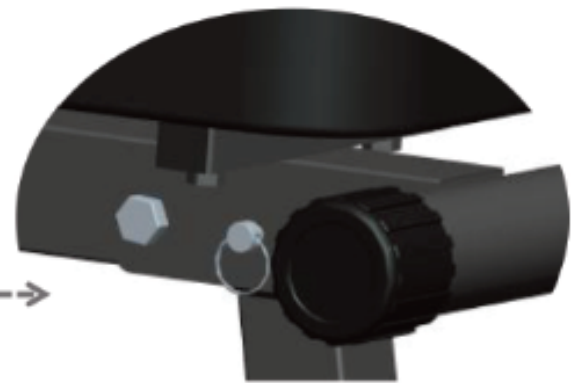

Take out the Bolt and fold it



Use Screw fix the sit up bench



IMPORTANT - CONSERVEZ CES INFORMATIONS
POUR VOTRE CONSULTATION ULTÉRIEURE: LISEZ ATTENTIVEMENT

INSTRUCTIONS D'ASSEMBLAGE

Installation

Étape 1: Ouvrez le package pour confirmer les composants du produit

Accessoires

A Tube de pied (2pcs)



B Cadre principal (y compris le couvercle du tube)



C Tube supérieur (2PCS)



D Coudière une paire



E Couverture de tube de fond



F Tube de support



G Barre de Gymnastique (y compris les gants de main)



H Connexion de base Tube



I Gants à la main I (4pcs)



J Tube de connexion de cadre principal



K Vis M8*65mm (22 pcs)



M Clé 13-17 (2pcs)



N Vis M8*75 (2 pcs)



O Vis 8*60 (2pcs)



P Écrou à vis M8(2pcs)



Q Vis M8*55 (4pcs)



R Ensemble de dossier Tube



T Tube de pied

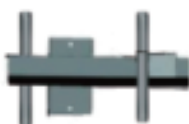

U Banc assis (Ensemble arrière)



V Joint en plastique



W Boulon 8*66 (2pcs)



X Vis M10*20mm (2pcs)



Y Vis (1pcs)



Z Vis M8*55(1pcs)



Étape 2 : Assemblage des 4 couvercle de pieds

Accessoires:

E Couvercle de Pied (4pcs)



A Tube de Pied 2 pcs



Utilisez des 4 couvercles de pieds pour insérer dans le tube à pied

Étape 3: Assemblage du tube de connexion inférieur

Accessoires:

H Tube de connexion de fond

K Vis M8x65mm(4pcs)



Vis M8*65

Étape 4 : Assemblage du cadre principal

Accessoires:

B du cadre principal



K Vis M8*65 (12pcs)



F Tube de soutien

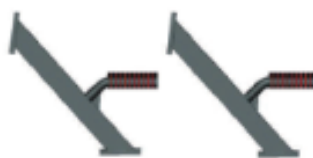

Étape 5: Assemblage du tube de connexion du cadre principal avec le tube de connexion de banc

K Vis M8x65mm(4pcs)

J Connexion de Cadre Principal



Vis M8x65mm
(À l'extérieur utilisez le joint plus grand)

Accessoires:

R Ensemble de dossier Tube



Vis M8*12mm

Étape 6 : Assemblage de la coudière

Accessoires : Q Vis M8x55(4pcs)

D Coudière une paire



Étape 7: Assemblage du tube supérieur et de la barre de gymnastique

Accessoires:

C Tube supérieur(2pcs)

G Barre de Gymnastique (avec gants à main)

N Vis M8x75(2pcs)



Étape 8: Ajustez les angles et les hauteurs appropriés

Accessoires:

O Vis 8x60(2pcs)

P Écrou à vis M8(2pcs)



Utiliser la Vis 8x60 pour fixer
Ajustement total 7

Installation complète sans banc(Voir photo)

Étape 9: Assemblage du banc assis (Utilisation)

V Joint en plastique X Vis M10x20mm(2pcs) U Bans Assis (ensemble de dossier)



U utiliser la vis M10X20 et mettre le joint au milieu

Étape 10 : Assemblage du tube de pied

K Vis M8x65mm+gros joint diamètre 30(2pcs)

T Tube de pied

W Boulon 8x66(1 pcs)

I Gants à la main I (4pcs)

Z Screw M8x55 (1pcs)

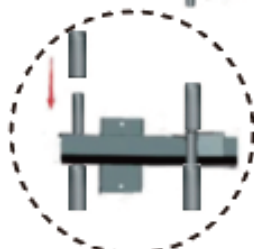

Insérez les gants à main
à main
(note: Utilisation
un peu d'eau sera
plus facile)

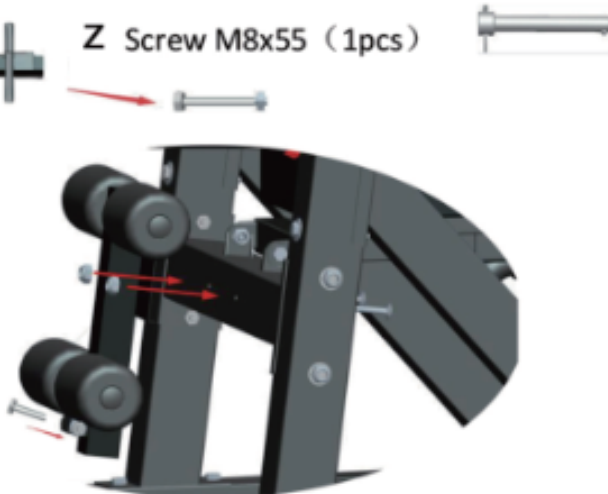

Vis M8x65mm(mettre 2 gros
joint)



Boulon pour ajuster le banc
assis pliable ou non



W Boulon 8x66

**Étape 11: Stockage
pliable: Accessoires:**

W Bolt 8x66(1pcs)



Y Vis (1pcs)

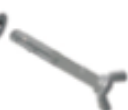

**Utilisez la vis pour fixer le
banc assis**



**IMPORTANTE - CONSERVE ESTA INFORMACIÓN
PARA SU CONSULTA POSTERIOR: LEER DETALLADAMENTE**

INSTRUCCIONES DE MONTAJE

Instalación

Paso 1: Abra el paquete y confirme los componentes del producto.

Accesorios

A Tubo para pies (2 piezas)



D Un par de almohadilla para codos (2 piezas)



G Barra del gimnasio (Incluidos las fundas para manos)



J Tubo de conexión del marco principal



M Llave 13-17 (2 piezas)



P Tuerca de tornillo M8 (2 piezas)



T Tubo para piernas

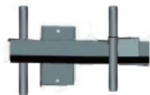

W Perno 8x66 (2 piezas)



B Marco principal (Incluida la cubierta del tubo)



E Cubierta del tubo inferior (4 piezas)



H Conexión de base



K Tornillo M8x65mm (22 piezas)



N Tornillo M8x75 (2 piezas)



Q Tornillo M8x55 (4 piezas)



U Banco de abdominales (Conjunto de respaldo)



C Tubo superior (2 piezas)

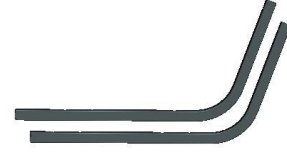

F Tubo de soporte (2 piezas)

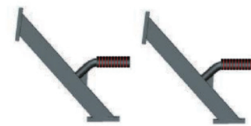

I Fundas para manos (4 piezas)



O Tornillo 8x60 (2 piezas)



R Conjunto de respaldo



V Junta de plástico (2 piezas)



Y Tornillo (1 pieza)



Z Tornillo M8x55 (1 piezas)



Paso 2: Montaje de cubiertas para 4 patas

Accesorios:

E Cubierta para patas (4 piezas)



A Tubo para pies (2 piezas)



Inserte las cubiertas para 4 patas en el tubo para pies.

Paso 3: Montaje del tubo de conexión inferior

Accesorios:

H Tubo de conexión inferior

K Tornillo M8x65mm (4 piezas)

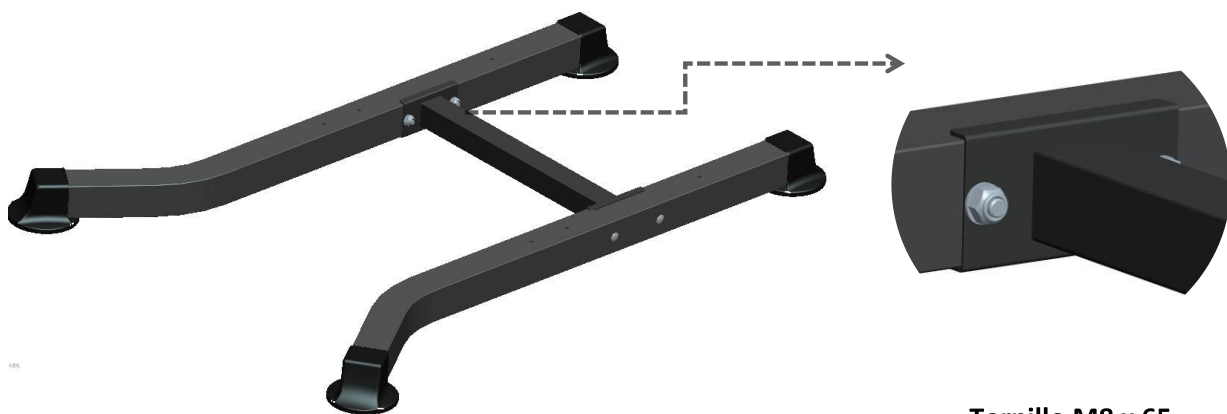

Tornillo M8 x 65

Paso 4: Montaje de marco principal

Accesorios:

B Marco principal



F Tubo de soportes

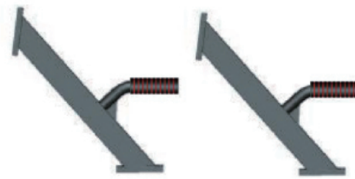

K Tornillo M8x65mm (12 piezas)



Tornillo M8x65mm
Nota: No apriételes todavía.

Tornillo M8x65mm
Nota: No apriételes todavía.

Paso 5: Conectar el tubo de conexión del marco principal con el tubo de conexión del banco

K Tornillo M8x65mm (4 piezas)



J Conexión del marco principal



Tornillo M8x65mm
(Use una junta más grande para el exterior)

Accesorios:

R Tubo de banco de abdominales



K Tornillo M8x65mm (2 piezas)



Paso 6: Montaje de almohadilla para codos

Accesorios: **Q** Tornillo M8x55 (4 piezas)

D Un par de almohadillas para codos



Paso 7: Montaje de tubo superior y barra de gimnasio

Accesorios:

C Tubo superior (2 piezas)



G Barra de gimnasio (con fundas para manos para manos)



N Tornillo M8x75 (2 piezas)



Paso 8: Ajustar ángulos y alturas adecuados

Accesorios:

O Tornillo 8x60 (2 piezas)



P Tuerca de tornillo M8 (2 piezas)

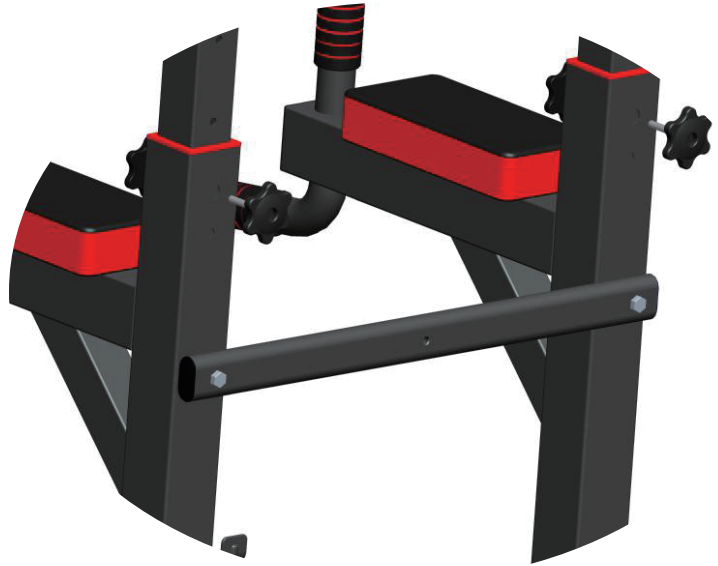

Utilice tornillo 8x60 para fijarlos.
Totalmente 7 ajustes

Instalación completa sin banco (Vea imagen)

Paso 9: Montaje banco para abdominales (Uso)

V Junta de plástico



X Tornillo M10x20mm
(2 piezas)



U Banco para abdominales
(Conjunto de respaldo)

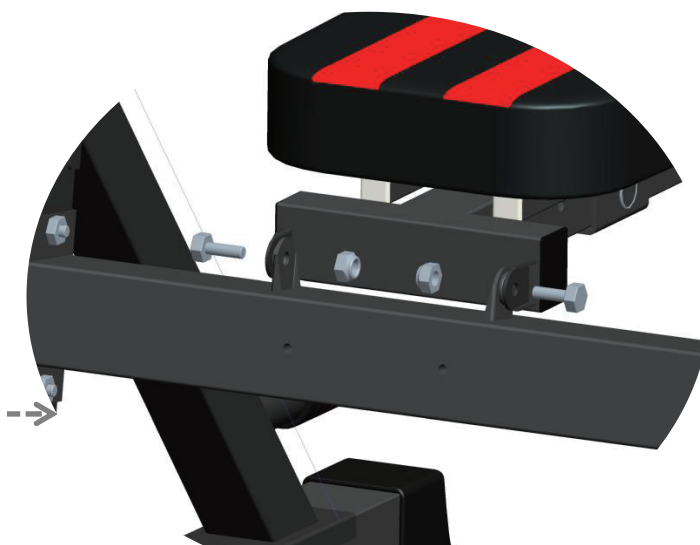

Utilic el tornillo M10X20, coloque la junta en el medio.

Paso 10: Montaje de tubo para pies

K Tornillo M8x65mm+junta grande dia30 (2 piezas)

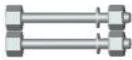

T Tubo para pies

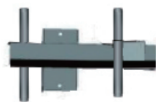

Z Tornillo M8x55 (1 pieza)



W Perno 8x66(1 pieza)



I Fundas para manos (4 piezas)



Inserte las fundas para manos
Nota : Use un poco de agua para facilitar insertarlos

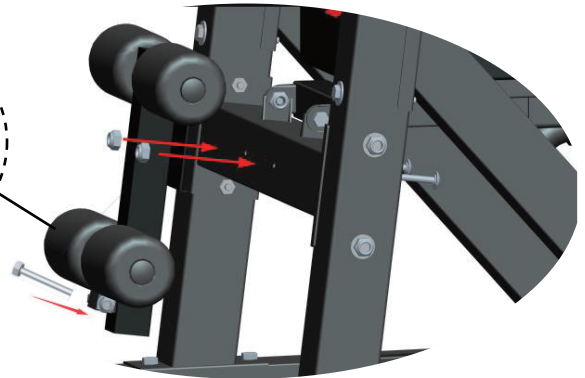
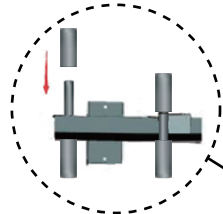

Utilice tornillo M8x65mm (Agregue 2 juntas grandes) .

Ajuste el perno para plegar o desplegar el banco de abdominales.

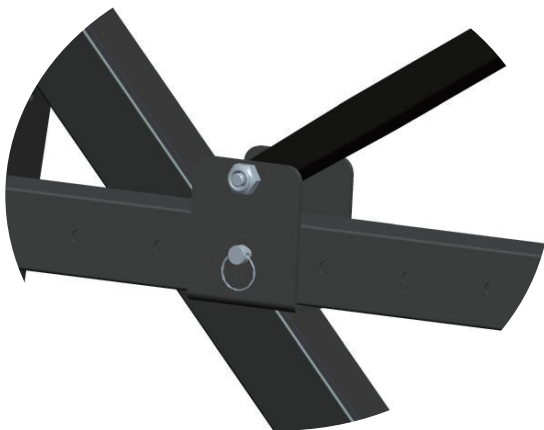

W Perno 8x66

Paso 11: Plegar para almacenamiento:

Accesorios:

W Perno 8x66(1 pieza)



Y Tornillo (1 pieza)

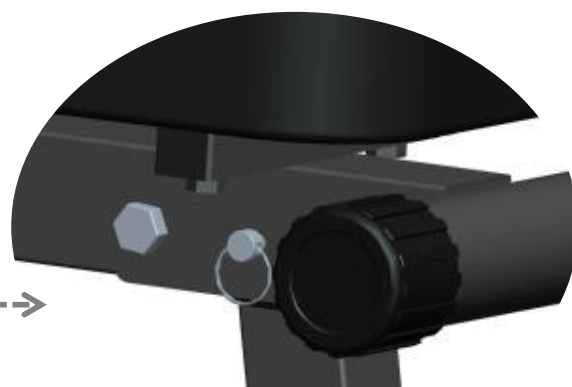

Saque el perno y pliéguelo.



Utilic el tornillo para fijar el banco de abdominales



IMPORTANTE - CONSERVARE QUESTE INFORMAZIONI
PER CONSULTARLE IN SEGUITO: LEGGERE ATTENTAMENTE

ISTRUZIONI DI ASSEMBLAGGIO

Installazione

Step 1: Aprire la confezione e confermare che vi siano tutti i componenti

Accessori

A Tubo a terra (2pz)



B Telaio (inclusa protezione tubi)



C Tubo superiore (2pz)



D Poggia gomiti (un paio)



E Cuscinetto tubi inferiori (4pz)



F Tubi di supporto



G Barra trazioni (inclusi guanti)



H Tubo connettore base



I guanti (4pz)



J Tubo connettore telaio principale



K Viti M8x65mm (22pz)



M Chiave 13-17 (2pz)



N Viti M8x75 (2pz)



O Viti 8x60 (2pz)



P Rondelle M8 (2pz)



Q Viti M8x55 (4pz)



R Tubo set posteriore



T Tubo gambe

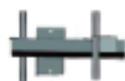

U Panca addominali (set posteriore)



V guarnizioni in plastica



W Viti 8x66(2pz)



X Viti M10x20mm(2pz)



Y Viti (1pz)



Z Viti M8x55 (1pz)



Step 2: Assemblare i 4 cuscinetti dei tubi inferiori

Accessori:

E cuscinetti (4pz)



A tubi a terra 2pz



Usare 4 cuscinetti e inserirli nei tubi a terra

Step 3: Assemblare il tubo connessione inferiore

Accessori:

H Tubo connessione inferiore



K Viti M8x65mm(4pz)

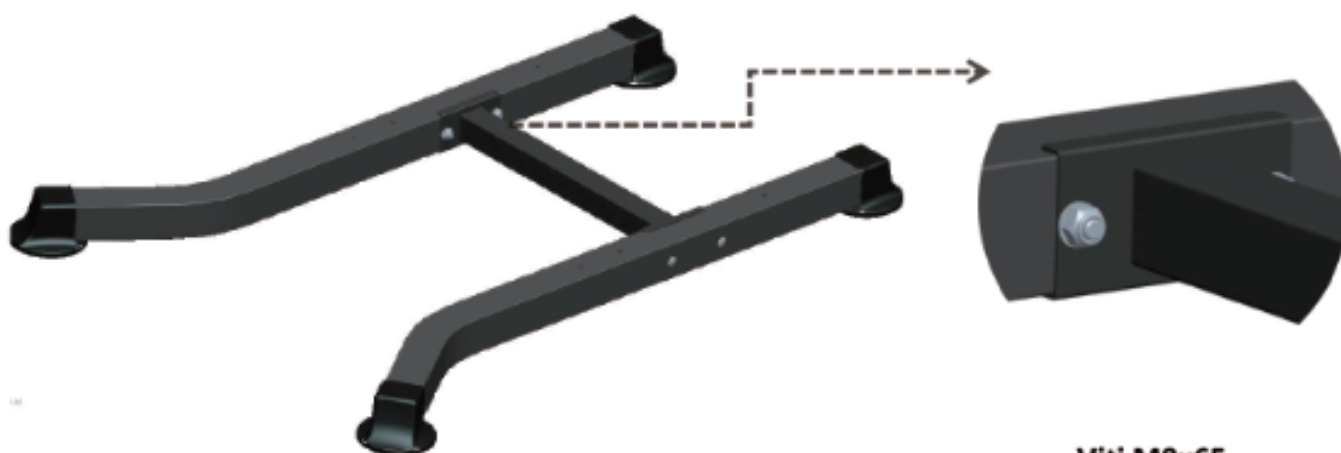

Viti M8x65

Step 4: Assemblare il telaio principale

Accessori:

B Telaio principale



F Tubi supporto

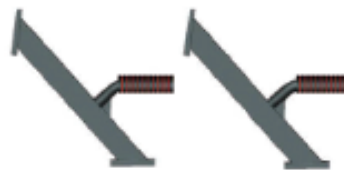

K Viti M8x65mm (12pcs)



Step 5: Assemblare il tubo connettore del telaio con il tubo del set posteriore

K Vite M8x65mm(4pz)



J Connettore telaio principale



**Viti M8x65mm
(guarnizioni grandi all'esterno)**

Accessori:

R Tubo panca addominali



Step 6: Assemblare i poggia gomiti

Accessori:

Q Viti M8x55 (4pz)

D Poggia gomiti, un paio



Step 7: Assemblare il tubo superiore e la barra trazioni

Accessori:

C Tubo superiore (2pz)

G Barra trazioni (con guanti)

N Viti M8x75 (2pz)



Step 8: Regolare l' altezza e l' inclinazione

Accessori:

○ Viti 8x60 (2pz)



P Rondelle M8 (2pz)



Usare viti 8x60
7 regolazioni possibili

Installazione completa senza panca (vedere la figura)

Step 9: Assemblare la panca addominali (figura)

V Guarnizioni in plastica

X viti M10x20mm(2pz)

U panca (set posteriore)

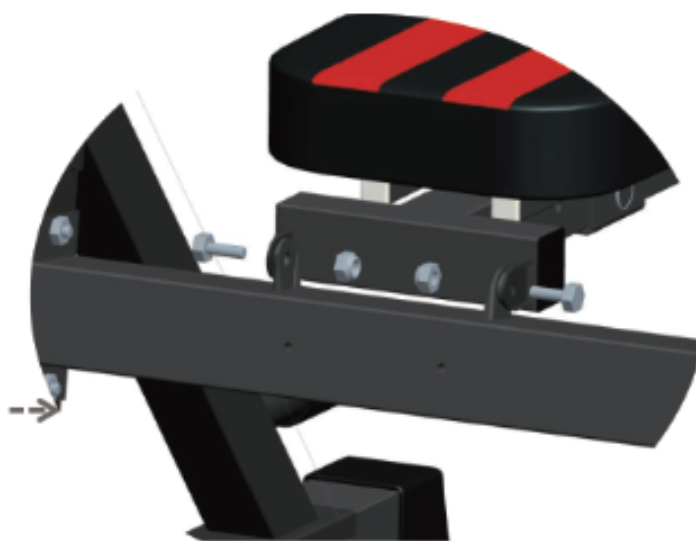

Usare viti M10X20 aggiungere guarnizione nel mezzo

Step 10: Assemblare i tubi gambe

K vite M8x65mm+ guarnizione grande dia30(2pz)

T tubi bambe

W vite 8x66(1pz)

Z Viti M8x55 (1pz)

I guanti (4pz)



W vite 8x66MM

Step 11: Ripiegare e conservare:

Accessori:

W viti 8x66(1pz)



Y Viti (1pcs)

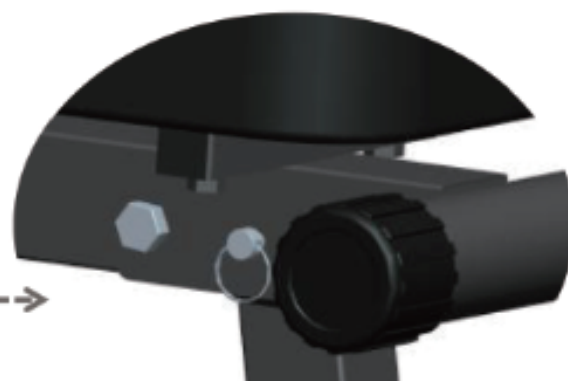

Rimuovere la vite e ripiegare



Usare la vite per fissare in posizione la panca

UK

If you have any questions, please contact our customer care center.

Our contact details are below:



0044-800-240-4004



enquiries@mhstar.co.uk

IMPORTER ADDRESS:

MH STAR UK LTD

Unit 27, Perivale Park,
Horsenden lane South

Perivale, UB6 7RH

MADE IN CHINA

ES

Si tiene alguna pregunta, comuníquese con nuestro Centro de Atención al Cliente. Nuestros datos de contacto son los siguientes:



0034-931294512



atencioncliente@aosom.es

IMPORTADOR:

SPANISH AOSOM, S.L.

C/ ROC GROS, N° 15. 08550, ELS HOSTALETS DE
BALENYÀ, SPAIN.

B66295775

WWW.AOSOM.ES

ATENCIONCLIENTE@AOSOM.ES

TEL: 931294512

HECHO EN CHINA

FR

Si vous avez la moindre question, veuillez contacter notre centre d'assistance à la clientèle.

Nos coordonnées sont les suivantes:



0033-1-84166106



aosom@mhfrance.fr

Importé par:

MH France

2, rue Maurice Hartmann

92130 Issy-les-Moulineaux

France

Fabriqué en Chine

IT

In caso di dubbio, si prega di contattare il nostro centro assistenza clienti.

I nostri dettagli di contatto sono di seguito:



0039-0249471447



clienti@aosom.it

IMPORTATO DA:

AOSOM Italy srl

Centro Direzionale Milanofiori

Strada 1 Palazzo F1

20057 Assago (MI)

P.I.: 08567220960

FATTO IN CINA