

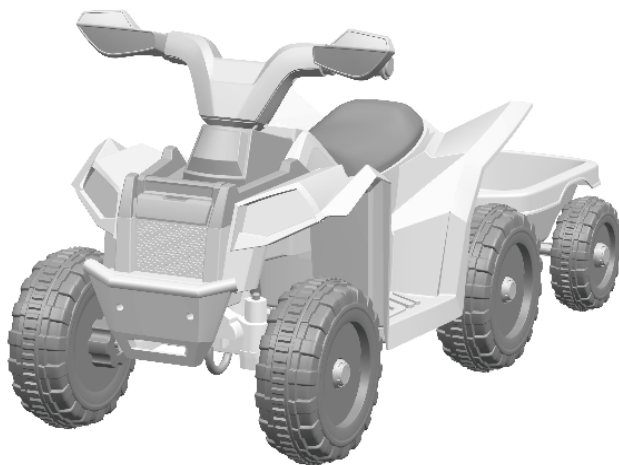

IN230600271V01_UK

370-277V70



Children's Beach Car With Trailer

- Suitable for 18+ months
- Maximum user weight: 25 kg



WARNING: Must be assembled by an adult.

Read and understand this entire manual before using!

Please keep this manual for future reference as it contains important information. Before first time use, charge the battery for at least 4-6 hours, but no more than 10 hours.

IMPORTANT, RETAIN FOR FUTURE REFERENCE: READ CAREFULLY

ASSEMBLY INSTRUCTION

On the purchase of your new Ride-On.

This ride-on car will provide your child with many miles of riding of enjoyment. To help assure you and your rider a safe ride we ask you to please read this manual carefully, and keep it for future reference.

Follow the recommendations in this manual, they are designed to improve the safety and operation of your ride-on car and its rider.

Specification

Battery	6V4.5AH X1
Charger	6V500mA
input	Depend on local voltage
Motor	390 9000-12000

Suitable age:	18 months+
Charge time:	8-12 hours
Load capacity:	Under 25 kg
Size of car:	1060 × 415 × 485 MM
Speed:	2.8-4.6 km/h



BATTERY INFORMATION

- Non-rechargeable batteries are not to be recharged.
- If removable rechargeable batteries are used, they are only to be charged under adult supervision.
- Remove rechargeable batteries from the product before charging.
- Do not mix old and new batteries. Do not mix different types of batteries: alkaline, standard (carbon-zinc) or rechargeable (nickel-cadmium).
- Insert batteries as indicated inside the battery compartment, anode to anode, cathode to cathode.
- Remove batteries during long periods of non-use. Always remove exhausted batteries from the product. Battery leakage and corrosion can damage this product. Dispose of batteries safely.
- Never short circuit the battery terminals.

NO.	PART NAME	Q'TY (PCS)		REMARK
1	Vehicle body	1		
2	Vehicle wheel	4		
3	Ø10 washer	9		
4	Lock nut	6		
5	Hubcap	6		
6	Steering column	1		
7	Front axle	1		
8	Ø4x16 screw	10		
9	Front bumper	1		
10	Seat	1		
11	Handle bar	1		
12	M5x50 machine screw	1		
13	Ø5 nut	2		
14	M5x30 machine screw	1		
15	Trailer	1		
16	Trailer axle	1		
17	Trailer linkage	1		
18	Ø4x10 washer head screw	3		
19	Trailer bushing	2		
20	Trailer wheel	2		
21	Trailer holder	1		
22	Label	1		
23	Socket wrench	2		
24	Charger	1		

Assembly tools required (not included): Screwdriver



Parts Diagram

3

HINT: Some parts shown are assembled on both sides of vehicle

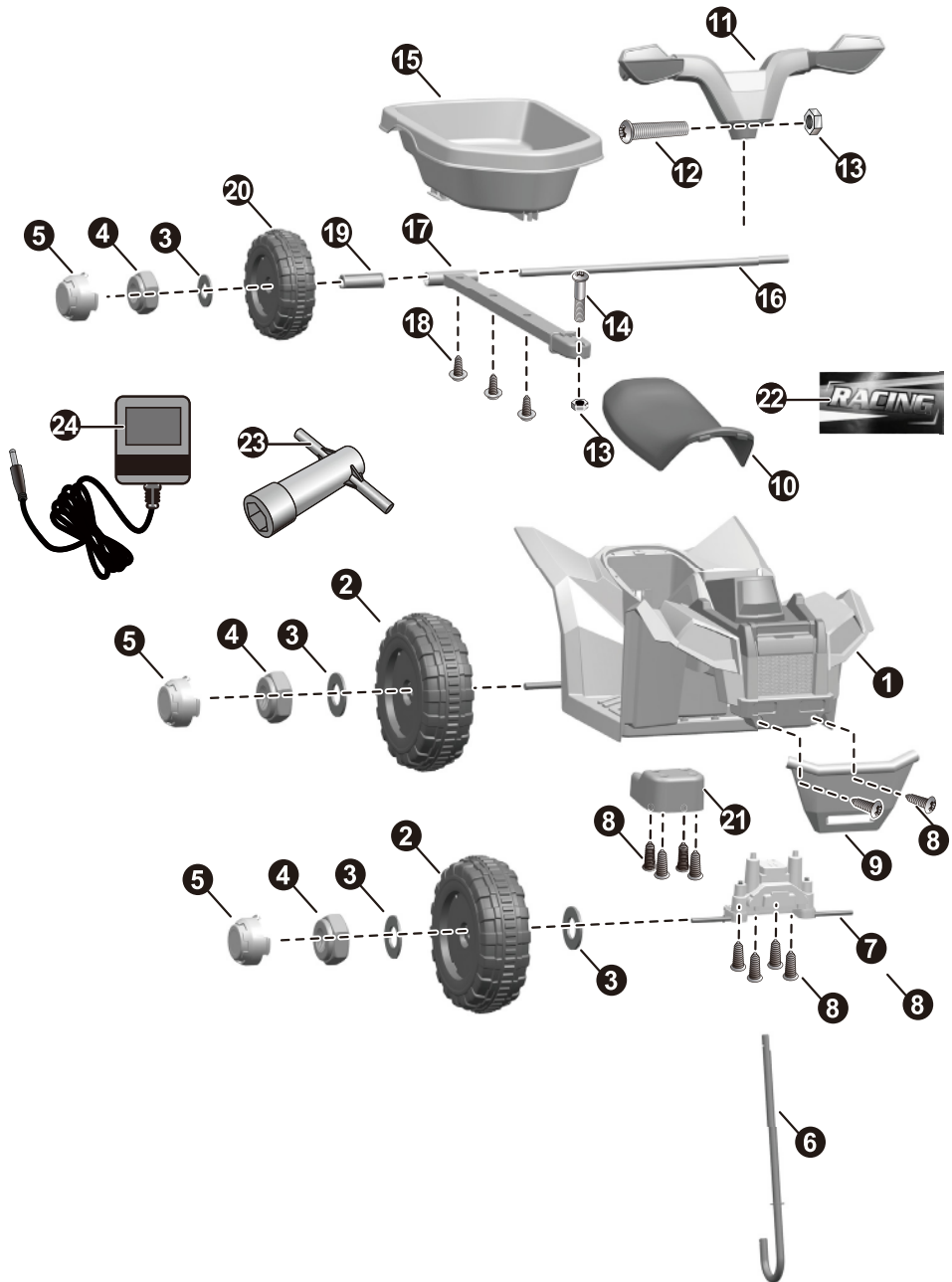



WARNING:

- **CHOKING HAZARD!**
- Must be assembled by an adult.
- To reduce the risk of injury, adult supervision is required.
- Never use in roadways, near motor vehicles, on or near steep inclines or steps, swimming pools or other bodies of water; always wear shoes, and never allow more than 1 rider.
- Power supply or battery charger used with the electric toy shall be regularly examined for damage to the supply cord, plug, enclosure or other parts, and in the event of damage, it shall not be used until the damage has been repaired.
- Use only battery(ies) and charger specified by the manufacturer.
- The battery on the vehicle is not replaceable.
- This toy should be used with caution since skill is required to avoid falls or collisions causing injury to the user or third parties.
- Protective equipment should be worn.
- Always wear shoes, always sit on the seat.
- Not to be used in traffic. user weight is 30 kg.
- This toy has no brake.

Rules for Safe Riding

- Keep Children within Safe Riding Areas.
- Use the toy only on flat surfaces. Such as inside your house, garden or playground.
- Never use in the dark. A child could encounter unexpected obstacles and have an accident. Operate the vehicle only in the daytime or a well-lit area.
- It is prohibited to change the circuit or add other electric parts
- Inspect wires and connections of the vehicle periodically.
- Do not let any child touch the wheels or be near them when the car is moving .
- This vehicle has adjustable play seat belts. Please instruct children how to tie the safety belt before using, guarantee the security.

Attach the Front Axle & Steering Column

5

- Gently turn the vehicle body upside down.
1. Fit the front axle linkage to the vehicle body.
 2. Insert four $\text{\O}4 \times 16$ screws through the front axle linkage and into the vehicle body, tighten with a screwdriver.

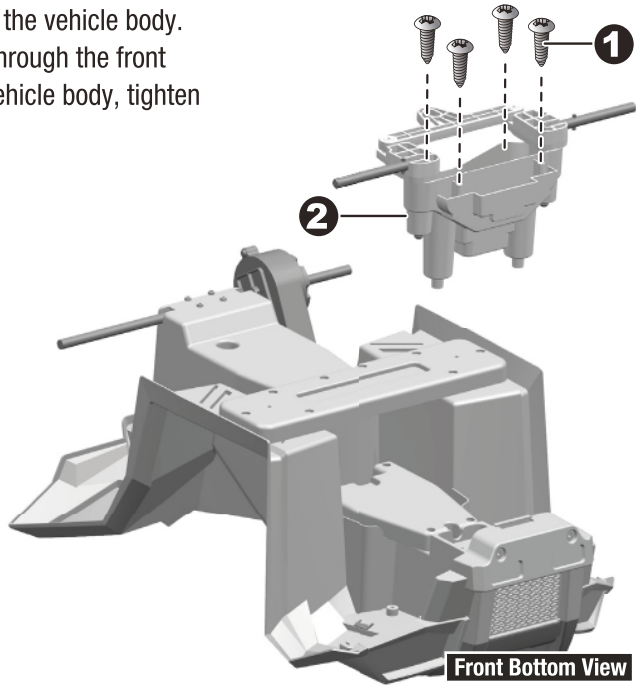

Rear Bottom View

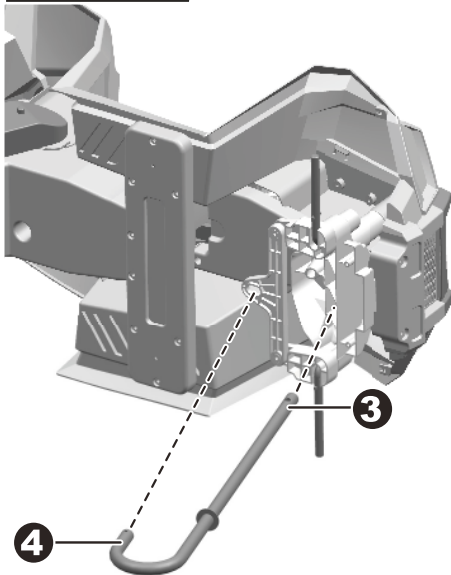

Front Bottom View

- Turn the vehicle body on its side.
3. Insert the straight end of the steering column into the hole on the vehicle body and out through the hole on the top of the vehicle body.
 4. Insert the bent end of the steering column into the hole on the front axle linkage.

Attach the Handle Bar & Front Bumper

6

- Turn the vehicle body over.
1. Fit the handle bar onto the end of the steering column.
 - 2&3. Line up the holes on the steering wheel with the holes on the steering column, insert the M5x50 machine screw. Fasten a nut on the opposite end of the screw.
 4. Fit the front bumper to the vehicle body.
 5. Insert two $\varnothing 4 \times 16$ screws and tighten with a screwdriver.
 6. Wash your hands and wipe the surface of the front bumper with a clean dry cloth, place the label exactly as shown.

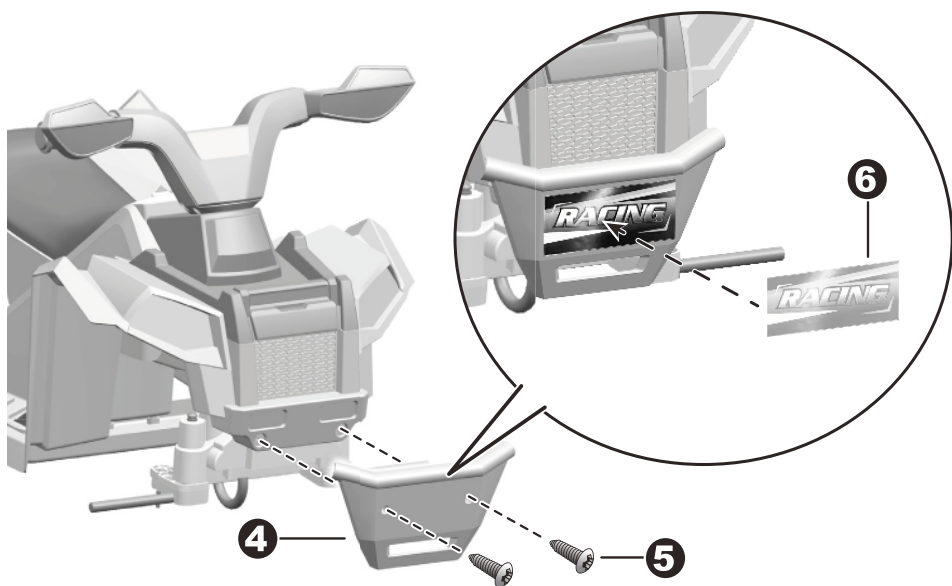
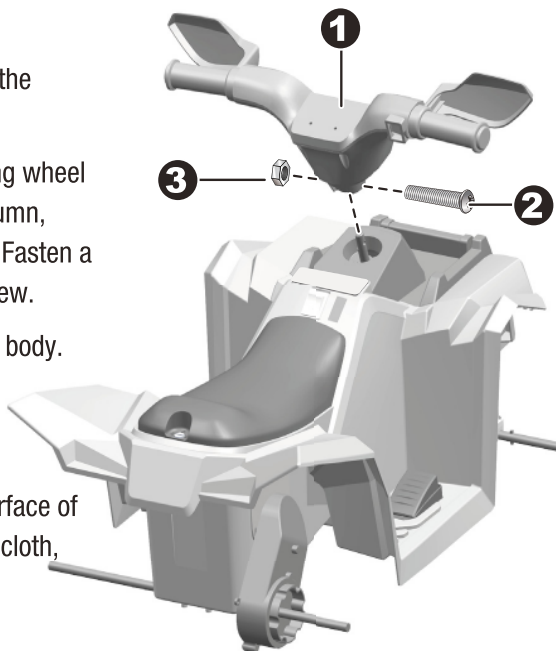

Rear View

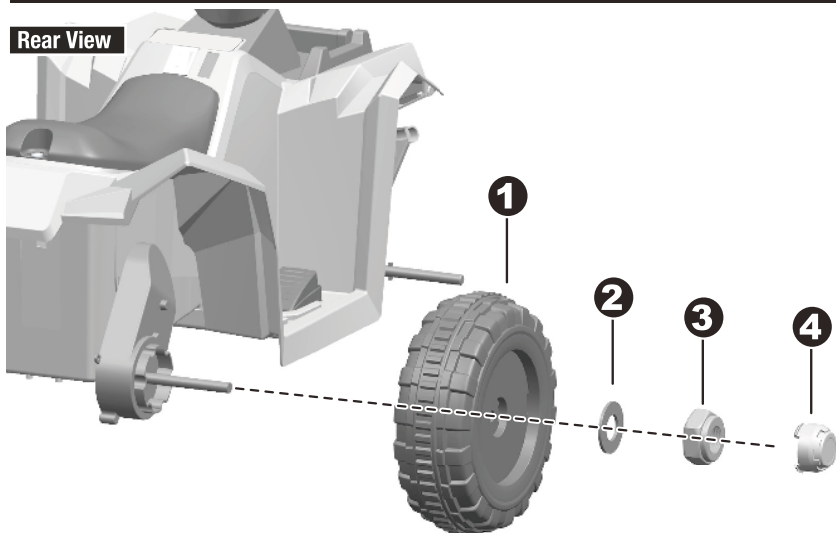

1. Slide a wheel onto the rear axle from the right side. Ensure the wheel match up with the gear box.
2. Slide a $\varnothing 10$ washer onto the rear axle.
3. Tighten a lock nut to the end of the rear axle with a socket wrench.
4. Insert the tabs on the hubcap into the grooves on the wheel.
5. Slide a $\varnothing 10$ washer onto the rear axle from the left side.
6. Slide a wheel onto the rear axle.
7. Slide a $\varnothing 10$ washer onto the rear axle.
8. Tighten a lock nut to the end of the rear axle with a socket wrench.
9. Insert the tabs on the hubcap into the grooves on the wheel.

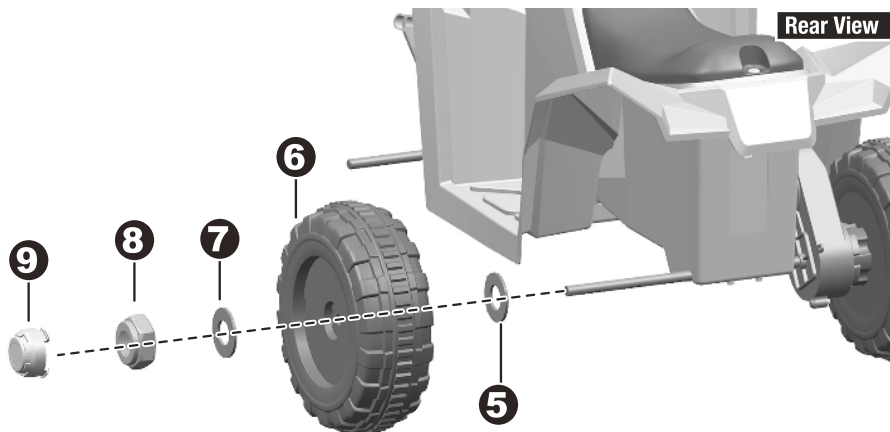

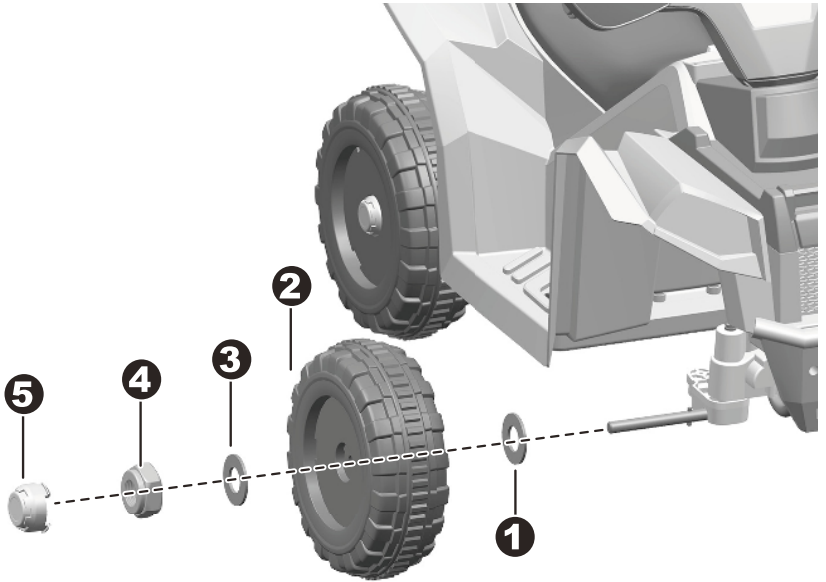

1. Slide a $\varnothing 10$ washer onto the front axle from the left side.
2. Slide a wheel onto the front axle.
3. Slide a $\varnothing 10$ washer onto the front axle.
4. Tighten a lock nut to the end of the front axle with a socket wrench.
5. Insert the tabs on the hubcap into the grooves on the wheel.

Repeat for the other front wheel.

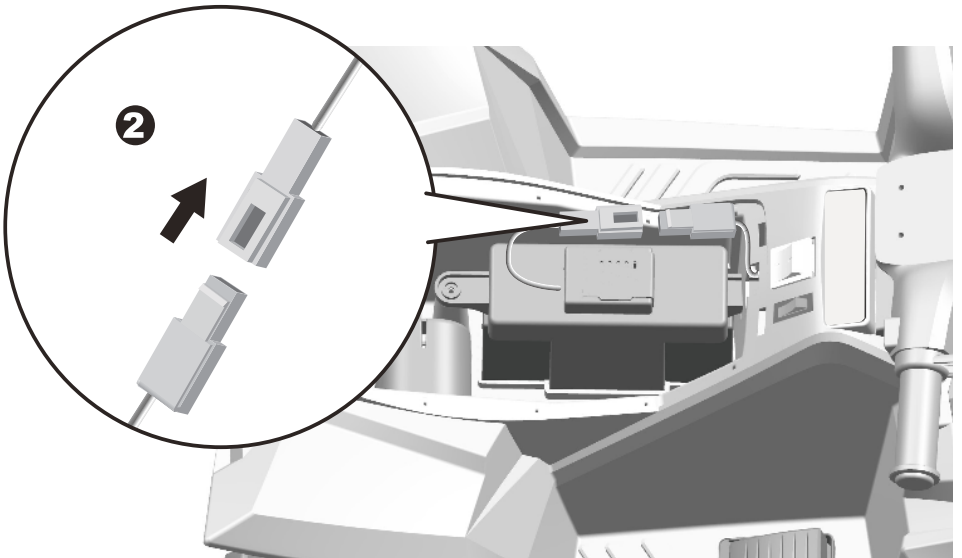
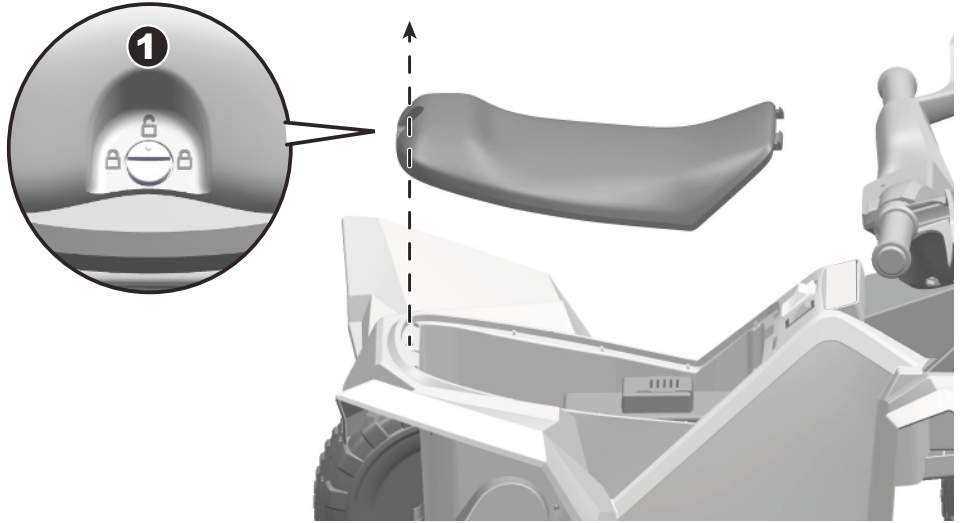

1. Using a slotted screwdriver(not included) or coin to unlock the seat lock, remove the seat from the vehicle body.
2. Pulg the vehicle connector into the connector from the battery. Replace the seat.

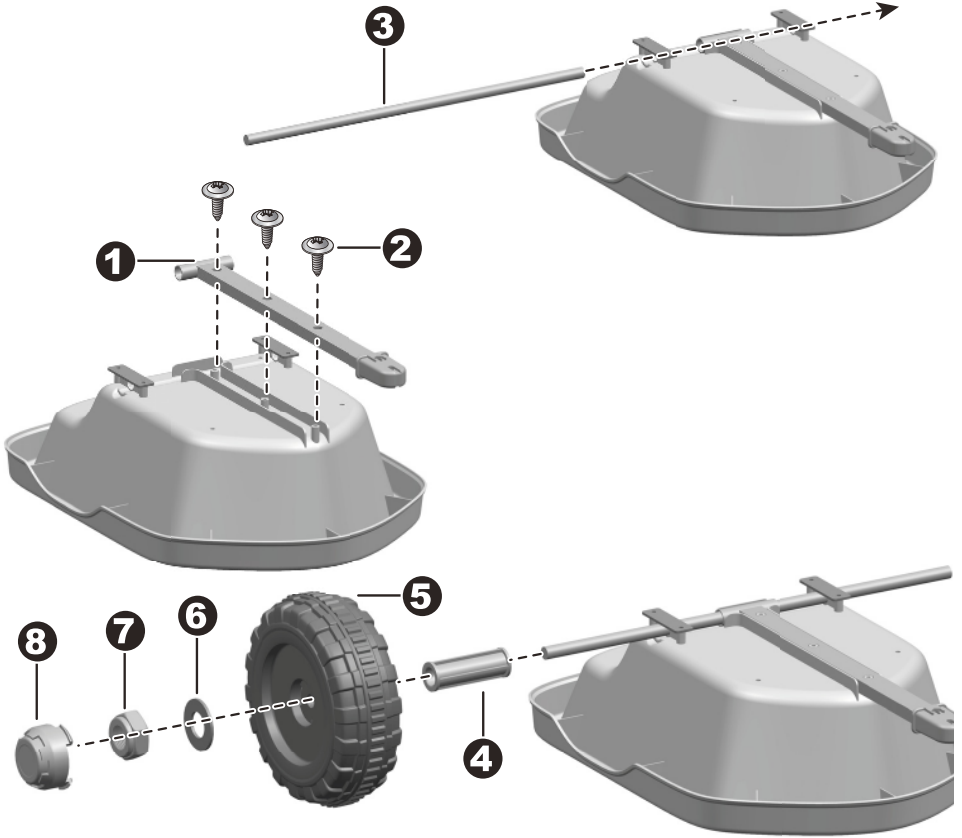

1. Turn the trailer down side up. Fit the trailer linkage to the trailer.
 2. Insert three $\text{\O}4 \times 10$ washer head screws and tighten with a screwdriver.
 3. Insert the trailer axle through into the holes in the trailer linkage.
 4. Slide a trailer washer onto the trailer axle.
 5. Slide a trailer wheel onto the trailer axle.
 6. Slide a $\text{\O}10$ washer onto the trailer axle.
 7. Tighten a lock nut to the trailer axle with a socket wrench.
- Repeat steps 4-7 to assemble the other trailer wheel to the trailer axle.
8. "Snap" a hubcap to the each trailer wheel.

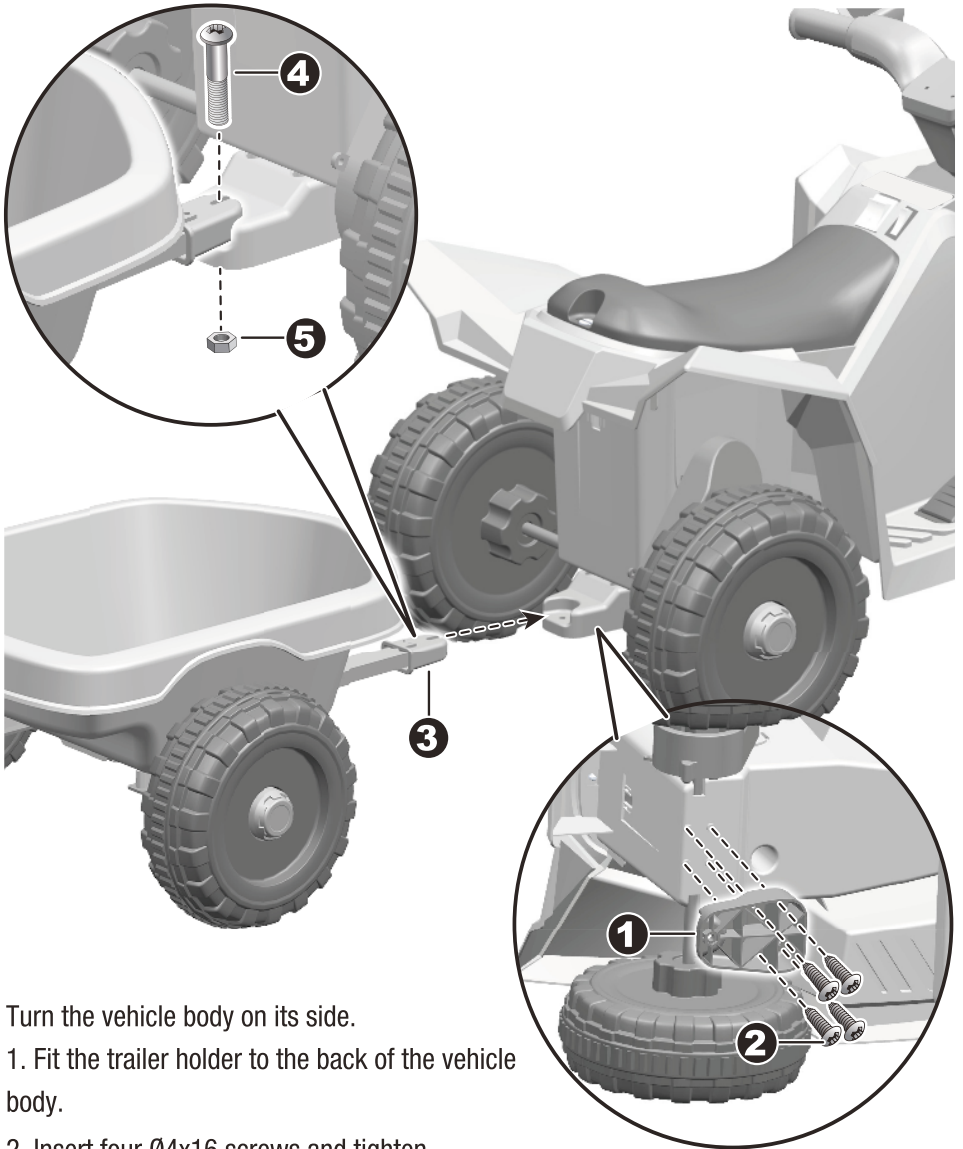

Turn the vehicle body on its side.

1. Fit the trailer holder to the back of the vehicle body.
2. Insert four $\varnothing 4 \times 16$ screws and tighten.
3. Fit the trailer assembly to the trailer holder.
- 4-5. Insert the M5x30 machine screw. Fasten a nut on the opposite end of the screw.

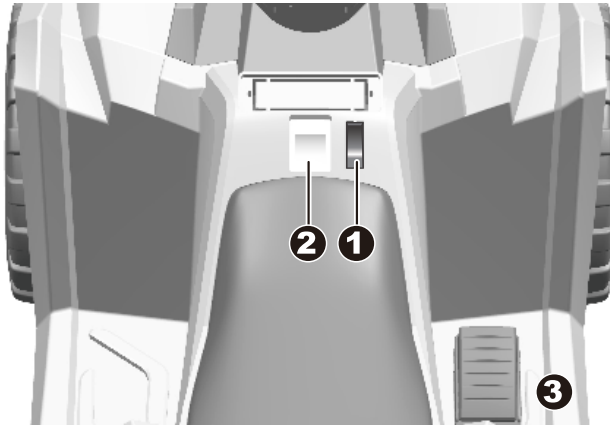

- 1. Power button:** Turn the product on and off.
- 2. Forward/Stop/Reverse lever:** Changes the direction that product moves from forward to reverse.
 - To move the product forward, shift the lever to top position.
 - To move the product backward, shift the lever to down position.
- 3. Throttle pedal:** Applies power (speed) to the product.
 - To move the product, press the pedal down.
 - To brake or slow down, release pressure from the pedal.

⚠ WARNING!**ONLY AN ADULT CAN CHARGE AND RECHARGE THE BATTERY!****⚠ WARNING!**

This product with **Charging Protection**: when charging, all functions will be cut off!
Only an adult can charge and recharge the battery!

- The POWER SWITCH must be turned in OFF position when charging.
- Before the first use, you should charge the battery for 4-6 hours. Do not recharge the battery for more than 10 hours to avoid overheating the charger.
- When the vehicle begins to run slowly, recharge the battery.
- After each use or once a month minimum recharge time as 8 to 12 hours, less than 20 hours at most.
- Use the only rechargeable battery and charger supplied with your vehicle. NEVER substitute the battery or the charger with another brand. Using another battery or charger may cause a fire or explosion.
- Do not use the battery or charger for any other product.

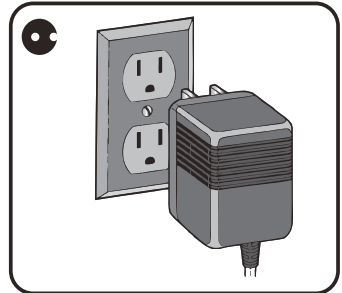
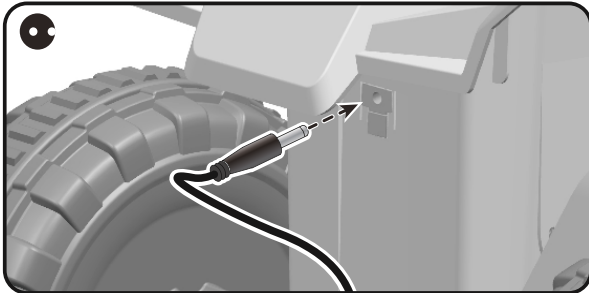
**How to charge the battery**

1. Open the charging cover (below the seat). Plug the charger port into the charger socket.
2. Plug the charger plug into a wall outlet. The battery will begin charging.

Problem	Possible Cause	Solution
Vehicle does not run	Battery low on power	Recharge battery.
	Thermal fuse has tripped	Reset fuse, see <Fuse>
	Battery connector or wires are loose	Check that the battery connectors are firmly plugged into each other. If wires are loose around the motor contact your distributor please.
	Battery is dead	Replace battery, contact your distributor please.
	Electrical system is damaged	Contact your distributor please.
	Motor is damaged	Contact your distributor please.
Vehicle does not run very long	Battery is under charged	Check that the battery connectors are firmly plugged into each other when recharging
	Battery is old	Replace battery, contact your distributor please.
Vehicle runs sluggishly	Battery low on power	Recharge battery, contact your distributor please.
	Battery is old	Replace battery, contact your distributor please.
	Vehicle is overload	Reduce weight on vehicle.
	Vehicle is being used in harsh conditions	Avoid using vehicle in harsh conditions ,see <Safety>.
Vehicle needs a push to go forward	Poor contact of wires or Connectors	Check that the battery connectors are firmly plugged into each other. If wires are loose around the motor, contact your distributor please.
	"Dead Spot" on motor	A dead spot means the electric power is not being delivered to the terminal connection and the vehicle needs repair. Contact your distributor please.
Difficult shifting from forward to reverse or vice-versa	Attempting to shift while the vehicle is motion	Completely stop the vehicle and shift, see <Use Your New Vehicle>
Loud grinding or clicking noises coming from motor or gear box	Motor or gears are damaged	Contact your distributor please.
Battery will not recharge	Battery connector or adapter connector is loose	Check that the battery connectors are firmly plugged into each other.
	Charger not plugged in	Check that the battery charger is plugged into a working wall outlet.
	Charger is not working	Contact your distributor please.
Charger feels warm when recharging	This is normal and not a cause for concern	

Completely read through this manual and the troubleshooting guide table before calling. If you still need help resolving the problem **Contact your distributor please.**

- It is parents' responsibility to check main parts of the toy before using, must regularly examine for potential hazard, such as the battery, charge, cable or cord, plug, screws are fastening enclosure of other parts and that in the event of such damage, the toy must not be used until that damage had been properly removed.
- Make sure the plastic parts of the vehicle are not cracked or broken.
- Occasionally use a lightweight oil to lubricate moving parts such as wheels.
- Park the vehicle indoors or cover it with a tarp to protect it from wet weather.
- Keep the vehicle away from sources of heat, such as stoves and heaters. Plastic parts may melt.
- Recharge the battery after each use. Only an adult can handle the battery. Recharge the battery at least once a month when the vehicle Raider is not being used.
- Do not wash the vehicle with a hose. Do not wash the vehicle with soap and water. Do not drive the vehicle in rainy or snowy weather. Water will damage the motor, electric system and battery.
- Clean the vehicle with a soft, dry cloth. To restore shine to plastic parts, use a non-wax furniture polish. Do not use car wax. Do not use abrasive cleaners.
- Do not drive the vehicle in loose dirt, sand or fine gravel which could damage the moving parts, motors or the electric system.
- When not using, all the electrical source should be turned off. Turn off the power switch and disconnect the battery connection.

The battery features a thermal fuse with a reset fuse that will automatically trip and cut all power to the vehicle if the motor, electric system or battery is overloaded. The fuse will reset and power will be restored after the unit is turned OFF for 20 seconds and then turned ON again. If the thermal fuse trips repeatedly during normal use, the vehicle may need repair. Contact your distributor please.

To avoid losing power, follow these guidelines:

- Do not overload the vehicle.
- Do not tow anything behind the vehicle.
- Do not drive up steep slopes.
- Do not drive into fixed objects, which may cause the wheels to spin, causing the motor to overheat.
- Do not drive in very hot weather, components may overheat.
- Do not allow water or other liquids to come in contact with the battery or other electric components.
- Do not tamper with the electric system. Doing so may create a short, causing the fuse to trip.

Our products are suitable for ASTM F963; GB6675; EN71 and EN62115 standard.

Disposal Of Battery



- Your sealed lead-acid battery must be recycled or disposed of in an environmentally sound manner.
- Do not dispose of your lead-acid battery in a fire. The battery may explode or leak.
- Do not dispose of a lead-acid battery in your regular, household trash. The incineration, land filling or mixing of sealed lead-acid batteries with household trash is prohibited by law.

Model identify	370-277V70	
Input voltage	AC 100-240	V
Input AC frequency	50/60	Hz
Output voltage	DC 6	V
Output current	0.5	A
Output power		W
Average active efficiency	74.9	%
Efficiency at low load (10 %)	61.4	%
No-load power consumption	0.07	W

UK

If you have any questions, please contact our customer care center.

Our contact details are below:



0044-800-240-4004



enquiries@mhstar.co.uk

IMPORTER ADDRESS:
MH STAR UK LTD
Unit 27, Perivale Park,
Horsenden lane South
Perivale, UB6 7RH
MADE IN CHINA

