



IN230700047V01\_UK\_FR\_ES\_DE\_IT

**342-008\_342-008V01**

**EN**



**UK  
CA  
CE**

**(55" ROUND TRAMPOLINE WITH SAFETY NET)**

**IMPORTANT, RETAIN FOR FUTURE REFERENCE: READ CAREFULLY**

**ASSEMBLY INSTRUCTION**

**WARNING**

Always install the trampoline with at least two people. keep head and face away from frame of trampoline. Failure to do so can cause serious injury to head or face, or lead to other serious injuries. We are not liable for any injuries that may occur when using the trampoline.

Table of contents

Parts list .....3 , 4









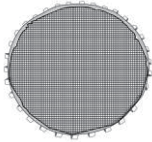

Notes & Warnings .....4

Assembly Instructions .....4, 5 , 6

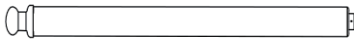
## Parts list

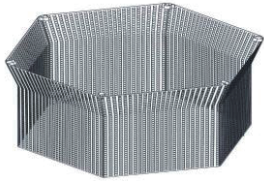
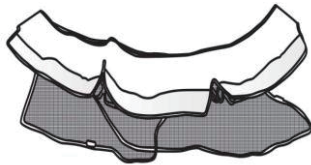
Ref.Number	Part Number	Description	Unit
1	TR01	Trampoline frame	6
2	TR02	Trampoline legs	6
3	TR03	Jump mat	1
4	TR04	Elastic springs	30
5	TR05	Net pole top	6
6	TR06	Net pole bottom	6
7	TR07	Net	1
8	TR08	Cover pad	1
9	TR09	Screws	30
10	TR10	Tool	1
11	TR11	Manual	1

 TR01 x 6pcs	 TR02 x 6pcs	 TR03 x 1pcs
 TR04 x 30pcs	 TR05 x 6 pcs	 TR06 x 6pcs
 TR07 x 1pcs	 TR08 x 1pcs	 TR09x 30pcs
 TR10 x 1pcs	 TR11 x 1pcs	

## Notes & Warnings

1. This product should not be used by persons weighting more than 45kgs.
2. The legs of the trampoline are installed tightly , please make sure not to pinch your fingers or hand during assembly.
3. The elastic springs can be stiff in the early stages of usage of the trampoline and will loosen with time. Please be careful while install the trampoline and do not hurt your body.
4. Must use elevated trampoline on wall to wall carpet or a floor than is not slippery so unit does not slide when used.

## Assembly Instructions

1. Lay all the trampoline part on the floor, connect 6 piece trampoline frame.

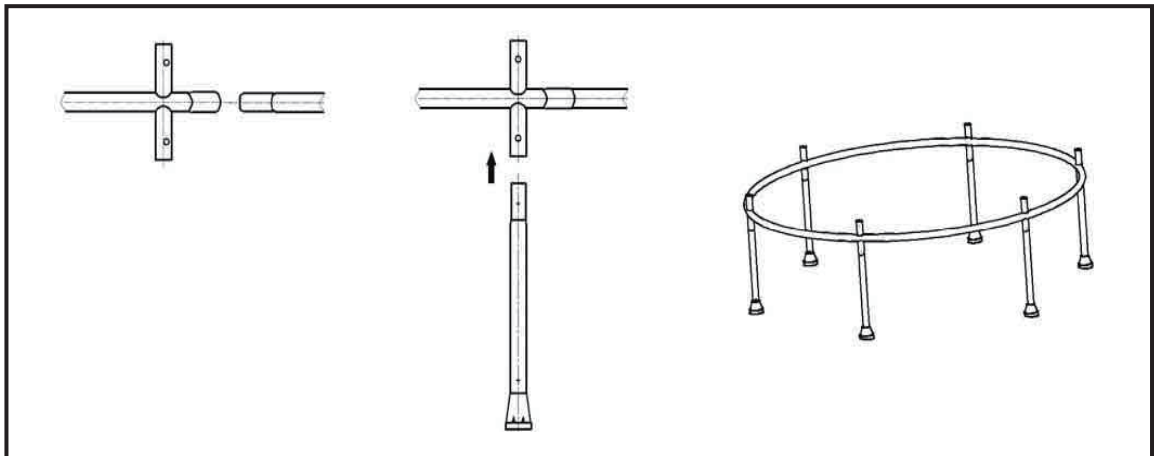

2. Install the leg tube into the main rack in turn .
3. With the trampoline frame now open and take out the jump mat in the middle of the frame ,now start to install the elastic springs, Install two elastic spring by two side of the frame ,Install the elastic spring to other two

side of the frame, keep on install other ropes as show. (attention: Install the jump mat need base on below Assembly Instructions)

Note: Please wear gloves when You install the elastic springs.

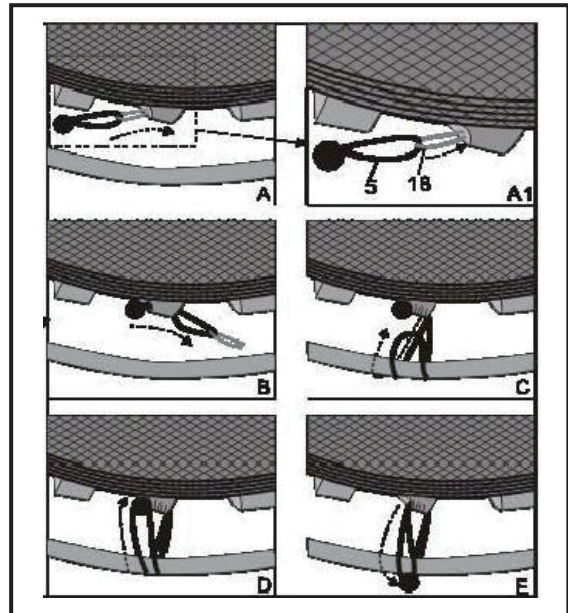
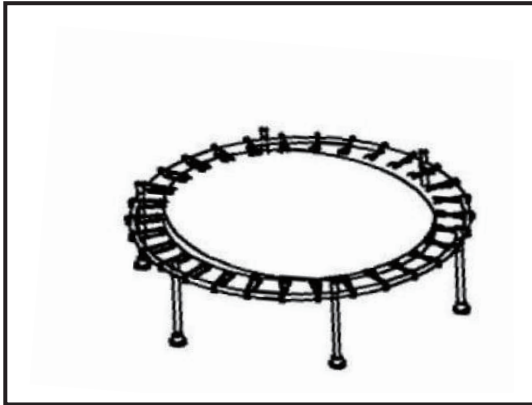

4. Put the cover pad onto the trampoline frame, Carefully position each of the 6 openings in the pad cover over their corresponding enclosure pole sockets.
5. Carefully work the lower mesh skirt down, around the entire perimeter of the trampoline, on the outside of the legs. Align the grommet attached to the bottom of the lower mesh skirt with the hole near the base of the leg and secure with screw.

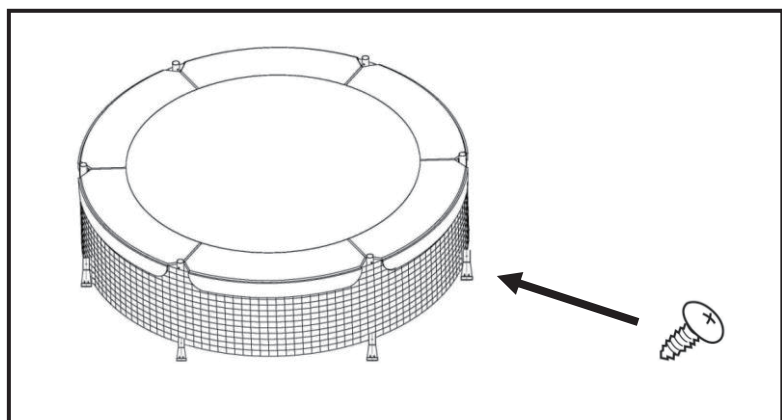

6. Insert the top net pole and bottom net pole into the main frame separately.

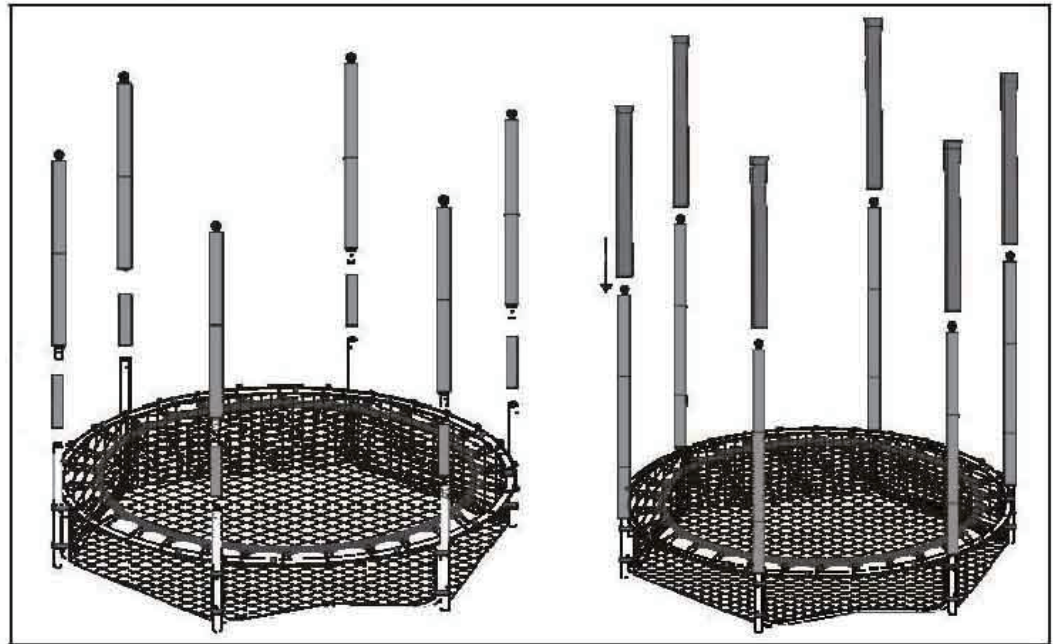

7. Secure the net from the top down to the main rack with the fastening buckle of the net on the ball head and tie the elastic band below to the pipe below.

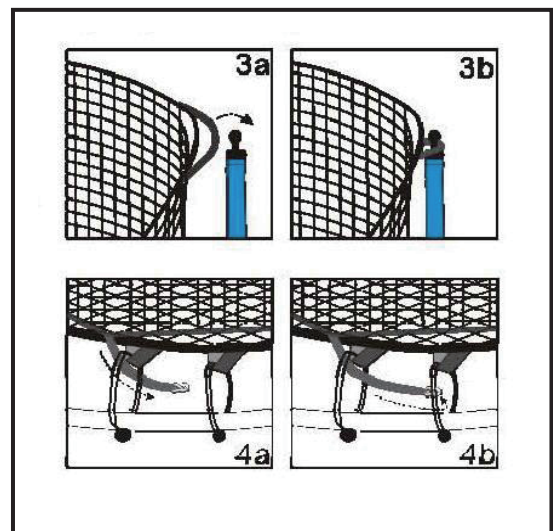
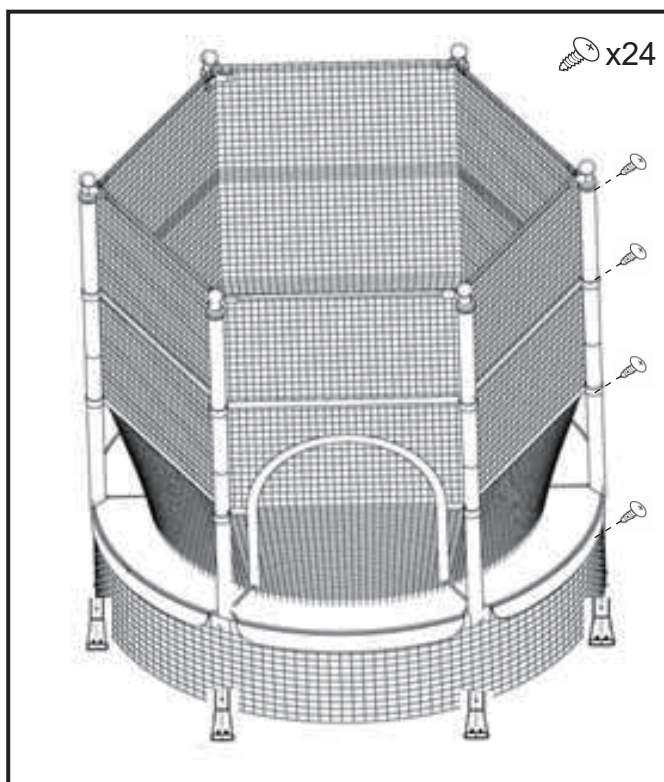



IN230700047V01\_UK\_FR\_ES\_DE\_IT

**342-008\_342-008V01**

FR



UK  
FR  
CE

(TRAMPOLINE ROND DE 55 " AVEC FILET DE SÉCURITÉ)

IMPORTANT - CONSERVEZ CES INFORMATIONS  
POUR VOTRE CONSULTATION ULTÉRIEURE: LISEZ ATTENTIVEMENT

**INSTRUCTIONS D'ASSEMBLAGE**

### **Avertissement**

**L'installation du trampoline doit être opérée par au moins 2 personnes. Maintenez la tête et le visage loin du cadre de trampoline. Le non-respect de cette consigne peut entraîner des blessures graves à la tête ou au visage, ou d'autres blessures graves. Nous ne sommes pas responsables des blessures qui pourraient survenir lors de l'utilisation du trampoline.**

### Table des matières

Liste des pièces.....	3, 4
Notes et avertissements.....	4
Instructions d'assemblage.....	4, 5, 6



## Liste des pièces

No. de Réf.	No de pièce	Description	Quantité
1	TR01	Cadre du trampoline	6
2	TR02	Pieds du trampoline	6
3	TR03	Tapis de saut	1
4	TR04	Ressorts élastiques	30
5	TR05	Poteau de filet	6
6	TR06	Fond du filet	6
7	TR07	Filet	1
8	TR08	couvre-ressorts	1
9	TR09	Vis	30
10	TR10	Outil	1
11	TR11	Manuel d'instructions	1



Tr01 x 6pcs



Tr02 x 6pcs

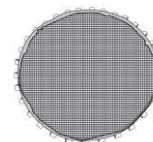

Tr03 x 1pcs



Tr04 x 30pcs



Tr05 x 6 pcs



Tr06 x 6pcs

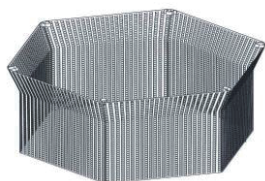

Tr07 x 1pcs

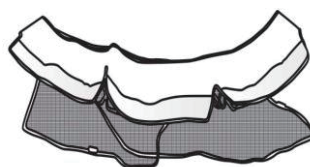

Tr08 x 1pcs



Tr09x 30 pcs



Tr10 x 1pcs



TR11 x 1pcs

## Notes et avertissements

1. Ce produit ne doit pas être utilisé par les personnes pesant plus de 45kg.
2. Les pieds du trampoline étant bien installés, veillez à ne pas blesser vos doigts et mains lors de l'assemblage du trampoline
3. Les ressorts élastiques peuvent être rigides dans les premiers stades de l'utilisation du trampoline et se desserreront avec le temps. Veuillez être prudent lors de l'installation du trampoline et ne pas blesser votre corps.
4. Veuillez installer le trampoline sur un tapis ou un sol non glissant pour éviter qu'il ne glisse lors de son utilisation.

## Instructions d'Assemblage

1. Posez toute la partie du trampoline sur le sol, connectez le cadre du trampoline en 6 pièces.

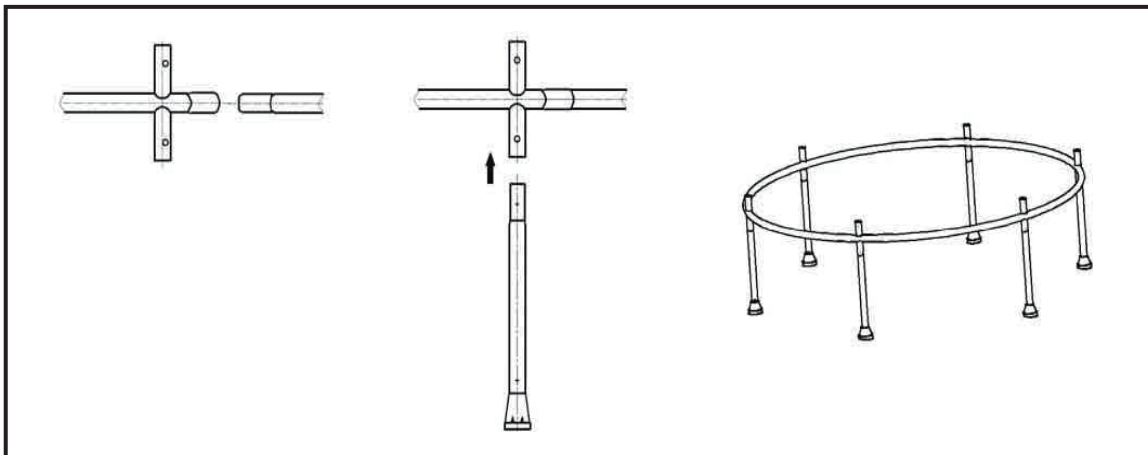

2. Installez le tube du pied dans le support principal.

3. Le cadre du trampoline étant ouvert, retirez le tapis de saut au milieu du cadre. Installez les ressorts élastiques, deux ressorts élastiques à côté du cadre et aux deux autres côtés du cadre, continuez à installer d'autres cordes comme montré. (Attention: Installez le tapis de saut comme ci-dessous)

**Note: Veuillez porter des gants lorsque vous installez les ressorts élastiques.**

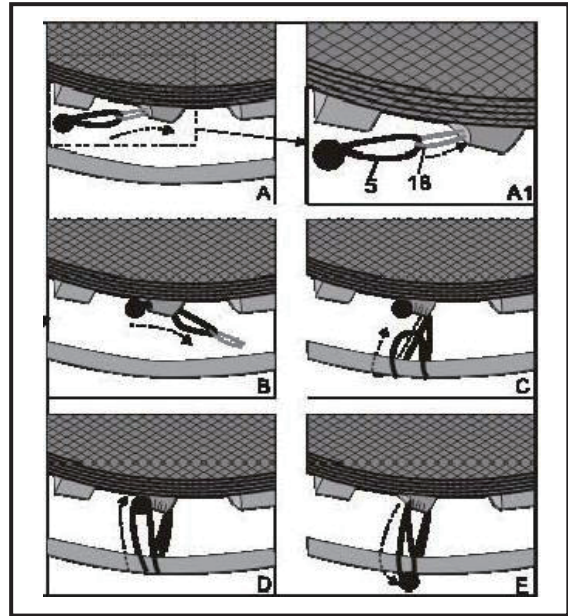
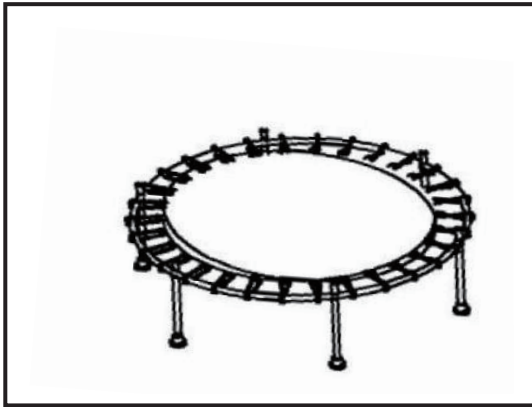

4. Placez le couvre ressorts sur le cadre du trampoline en positionnant soigneusement les 6 ouvertures dans le couvre ressorts, sur les prises de poteau correspondantes.

5. Placez avec précaution le filet inférieur vers le bas sur tout le périmètre du trampoline, à l'extérieur des poteaux. Alignez l'œillet fixé au bas du filet inférieur avec le trou situé près de la base du poteau et fixez-le avec un vis.

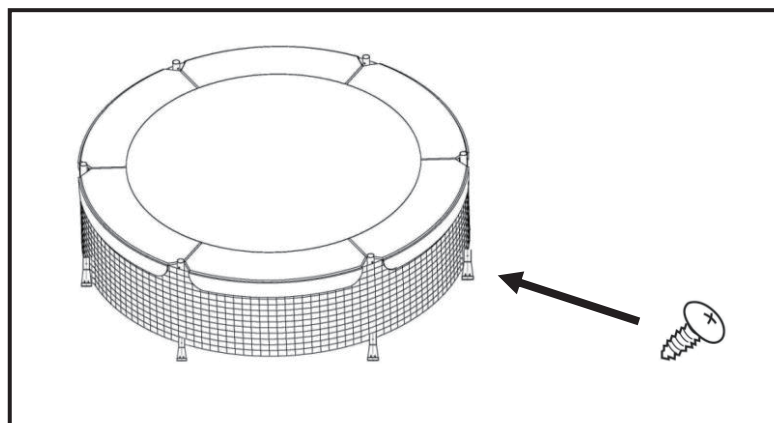

6. Insérez séparément le poteau du filet supérieur et le poteau du filet inférieur dans le cadre principal.

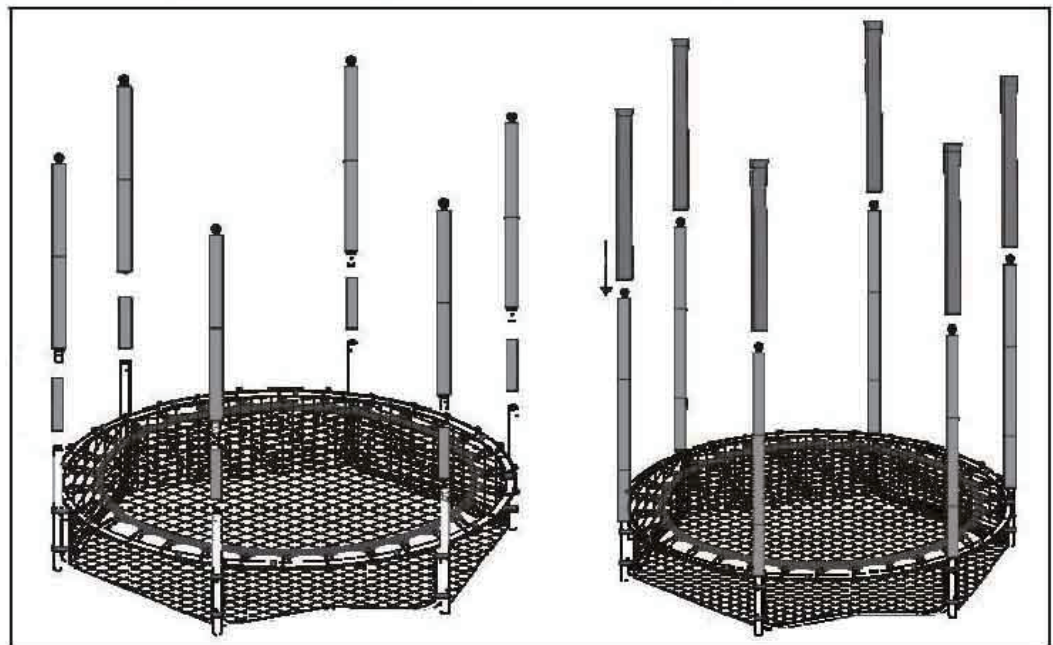

7. Fixez le filet du haut vers le bas jusqu'au support principal avec la boucle de fixation du filet sur l'embout supérieur et attachez la bande élastique au tuyau comme ci-dessous.

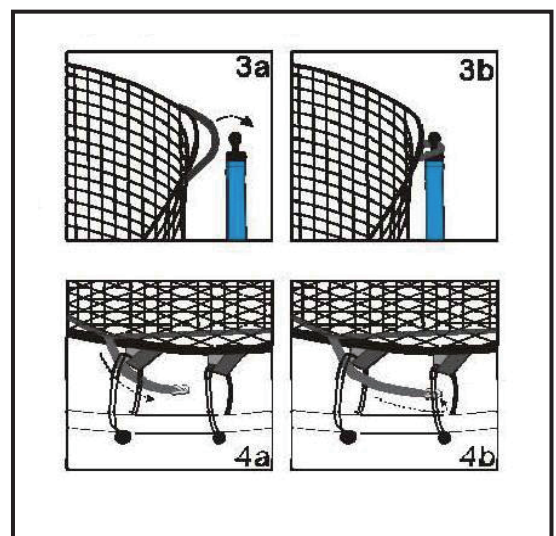
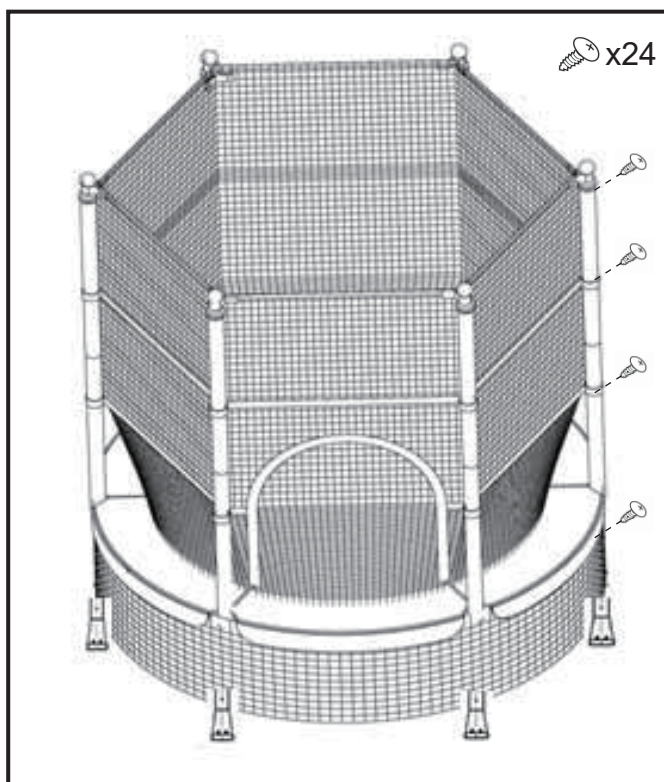



IN230700047V01\_UK\_FR\_ES\_DE\_IT

**342-008\_342-008V01**

ES



UK  
CA  
CE

**(TRAMPOLÍN REDONDO DE 55 " CON RED DE SEGURIDAD)**

**IMPORTANTE - CONSERVE ESTA INFORMACIÓN  
PARA SU CONSULTA POSTERIOR: LEER DETALLADAMENTE**

**INSTRUCCIONES DE MONTAJE**

## **ADVERTENCIA**

El trampolín debe ser instalado por al menos dos personas.  
Mantenga la cabeza y la cara alejadas del marco del trampolín.  
De lo contrario, puede provocar lesiones graves en la cabeza o la cara, o otras lesiones graves. No nos hacemos responsables de las lesiones que puedan ocurrir al utilizar el trampolín.

### Tabla de contenido

Lista de partes.....	3, 4
Notas y advertencias.....	4
Instrucciones de montaje.....	4, 5, 6

## Lista de Partes

Número de referencia	Número de la pieza	Descripción	Unidad
1	TR01	Marco del trampolín	6
2	TR02	Patas del trampolín	6
3	TR03	Estera para salto	1
4	TR04	Resortes elásticos	30
5	TR05	Parte superior del poste de la red	6
6	TR06	Parte inferior del poste de la red	6
7	TR07	Red	1
8	TR08	Almohadilla de cubierta	1
9	TR09	Tornillos	30
10	TR10	Herramienta	1
11	TR11	Manual	1

		
TR01 x 6piezas	TR02 x 6piezas	TR03 x 1pieza
		
TR04 x 30piezas	TR05 x 6 piezas	TR06 x 6piezas
		
TR07 x 1pieza	TR08 x 1pieza	TR09x 30piezas
		
TR10 x 1pieza	TR11 x 1pieza	

## Notas y Advertencias

1. Este trampolín no debe ser utilizado por las personas que pesen más de 45 kg.
2. Las patas del trampolín están instaladas firmemente, asegúrese de no pillarse los dedos o la mano cuando usted realice el montaje.
3. Los resortes elásticos pueden estar duros en las primeras etapas de utilizar el trampolín y se aflojarán con el tiempo. Tenga cuidado al instalar el trampolín y no dañe su cuerpo.
4. Debe utilizar este trampolín elevado sobre una alfombra de pared a pared o sobre un piso que no sea resbaladizo para que el trampolín no se deslice cuando se utiliza.

## Instrucciones de montaje

1. Coloque todas las partes del trampolín sobre el suelo, conecte las 6 piezas del marco del trampolín.

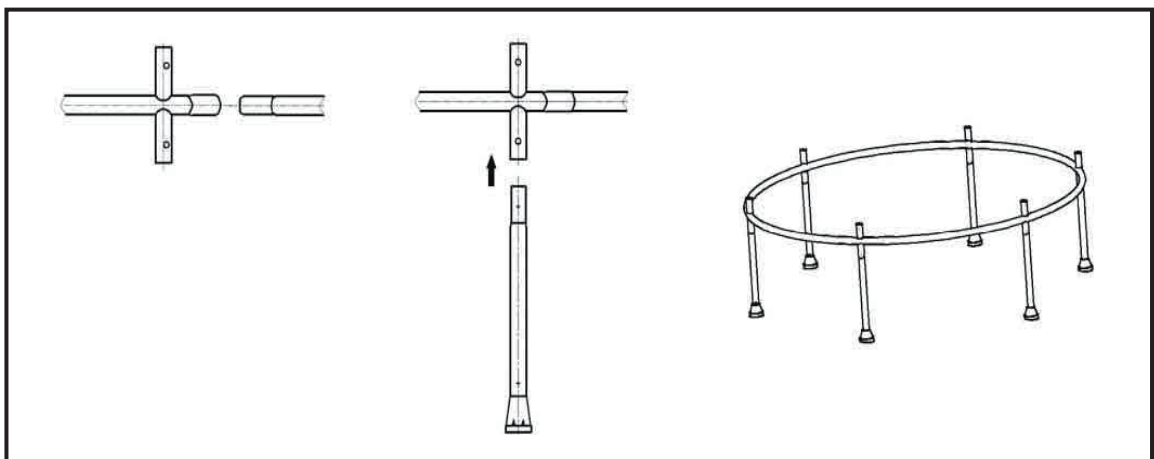

2. Instale el tubo de la pata en la rejilla principal por turno.
3. Ahora el marco del trampolín está abierto y saque la estera para salto en el



centro del marco, ahora empiece a instalar los resortes elásticos, primero instale 2 resortes elásticos en los dos lados del marco, luego instale el resorte elástico en los otros dos lados del marco. Siga instalando las otras cuerdas como lo que se muestra en la imagen. (Atención: Instale la base de la estera para salto de acuerdo con las instrucciones de montaje siguientes)

Nota: Utilice los guantes al instalar los resortes elásticos.

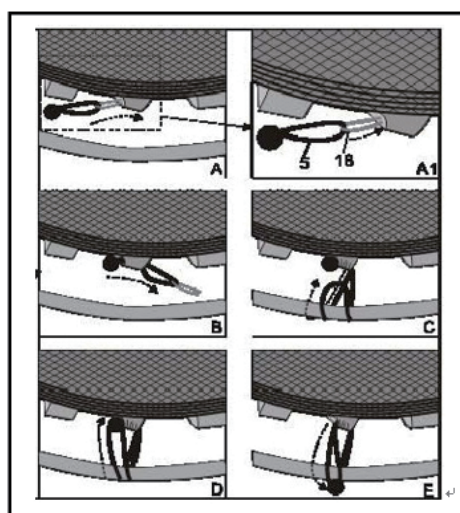
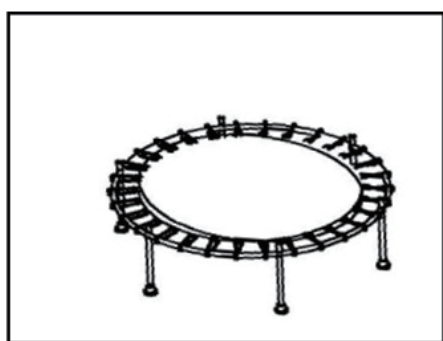

4. Coloque la almohadilla de la cubierta en el marco del trampolín, coloque cuidadosamente cada una de las 6 aberturas en la cubierta de la almohadilla sobre sus tomas de poste del recinto correspondientes.

5. Instale cuidadosamente el faldón de malla inferior hacia abajo que debe ser instalado alrededor de todo el perímetro del trampolín, en la parte exterior de las patas. Alinee el ojal unido a la parte inferior del faldón de malla inferior con el orificio correspondiente que está cerca de la base de la pata y

fielo con un tornillo.

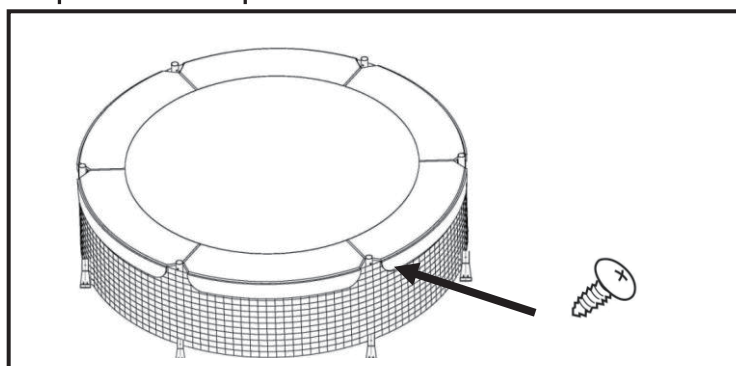

6. Inserte la parte superior del poste de la red y la parte inferior del poste de la red en el marco principal separadamente.

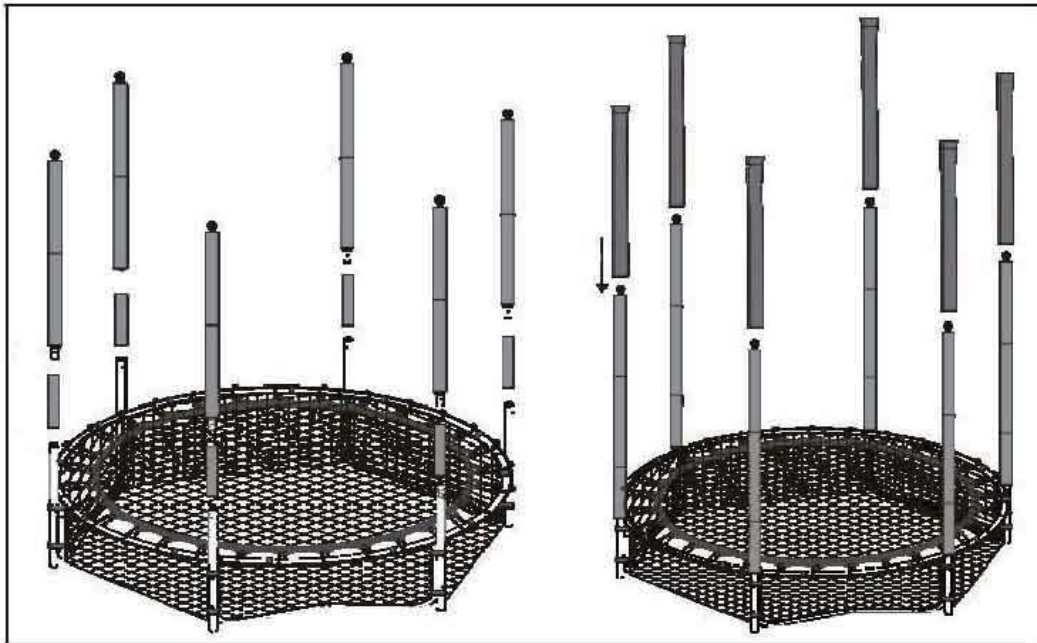

7. Fije la red de arriba hacia abajo a la rejilla principal utilizando la hebilla de sujeción de la red en la cabeza de la bola y ate la banda elástica de abajo al

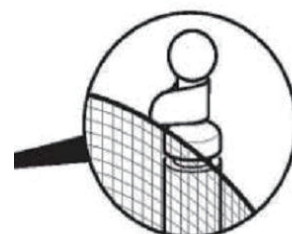
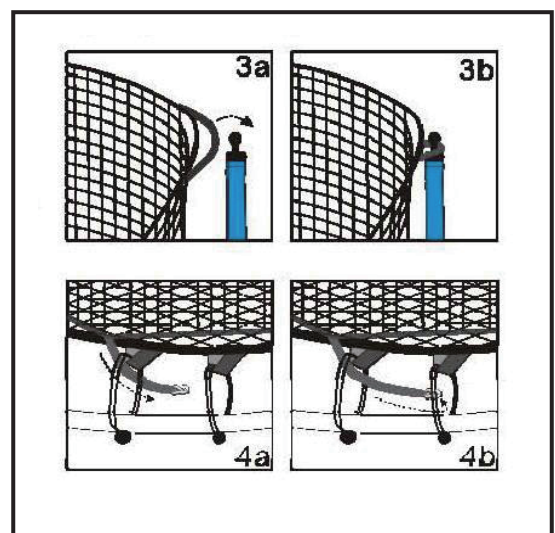
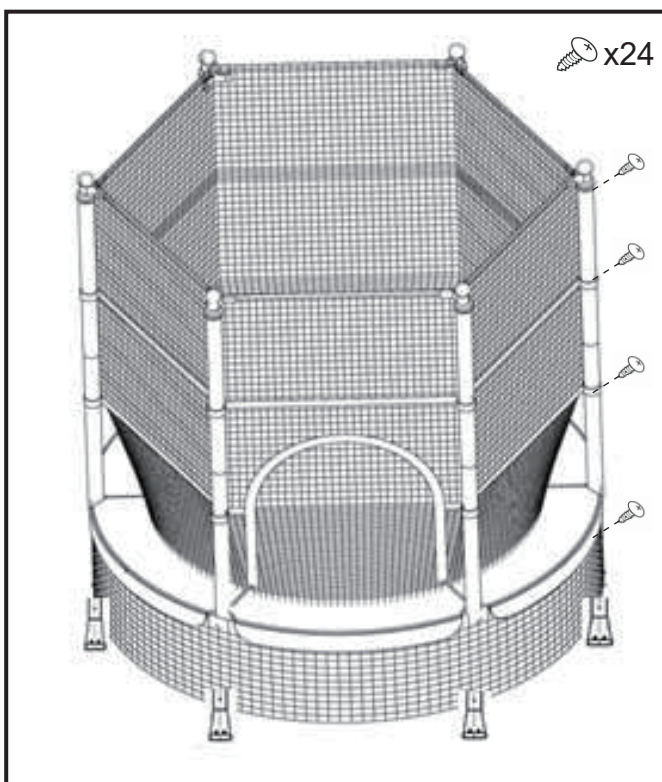



IN230700047V01\_UK\_FR\_ES\_DE\_IT

**342-008\_342-008V01**

DE



UK  
FR  
CE

(55"-RUNDTRAMPOLIN MIT SICHERHEITSNETZ)

WICHTIG - BITTE HEBEN SIE DIESE ANLEITUNG FÜR  
EINE SPÄTERE BEZUGNAHME AUF: SORGFÄLTIG DURCHLESEN

**MONTAGEANLEITUNG**

### **WARNUNG**

Installieren Sie das Trampolin immer mit mindestens zwei Personen. Halten Sie Kopf und Gesicht vom Trampolinrahmen fern. Andernfalls kann es zu schweren Verletzungen an Kopf oder Gesicht oder zu anderen schweren Verletzungen kommen. Wir haften nicht für Verletzungen, die bei der Benutzung des Trampolins auftreten können.

## Inhaltsverzeichnis

Teilliste.....	3, 4
Hinweise und Warnungen.....	4
Montageanleitung.....	4, 5, 6

# Teilliste

Ref. Numme	Teilnr.	Beschreibung	Anzahl
1	TR01	Trampolin-Rahmen	6
2	TR02	Trampolin-Beine	6
3	TR03	Sprungmatte	1
4	TR04	Elastische Federn	30
5	TR05	Mastspitze Netz	6
6	TR06	Netzmast unten	6
7	TR07	Netz	1
8	TR08	Abdeckpolster	1
9	TR09	Schrauben	30
10	TR10	Werkzeug	1
11	TR11	Handbuch	1



Tr01 x 6 Stck.



Tr02 x 6 Stck.

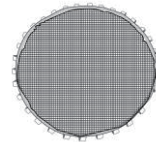

Tr03 x 1 Stck.



Tr04 x 30 Stck.



Tr05 x 6 Stck.

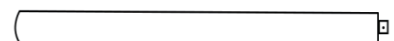

Tr06 x 6 Stck.

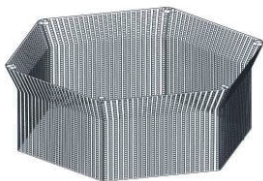

Tr07 x 1 Stck.

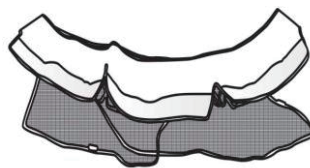

Tr08 x 1 Stck.



Tr09x 30 Stck.



Tr10 x 1 Stck.



Tr11 x 1 Stck.

## Hinweise und Warnungen

1. Dieses Produkt sollte nicht von Personen verwendet werden, die mehr als 45 kg wiegen.
2. Die Beine des Trampolins sind fest montiert, bitte achten Sie darauf, dass Sie sich beim Zusammenbau nicht die Finger oder die Hand einklemmen.
3. Die elastischen Federn können in der Anfangsphase der Benutzung des Trampolins steif sein und lösen sich mit der Zeit. Bitte seien Sie beim Einbau des Trampolins vorsichtig und verletzen Sie Ihren Körper nicht.
4. Muss ein erhöhtes Trampolin auf einem Teppich von Wand zu Wand oder auf einem Boden verwenden, der nicht rutschig ist, damit das Gerät beim Gebrauch nicht rutscht.

## Montageanweisungen

1. Legen Sie das gesamte Trampolinteil auf den Boden, verbinden Sie den 6-teiligen Trampolinrahmen.

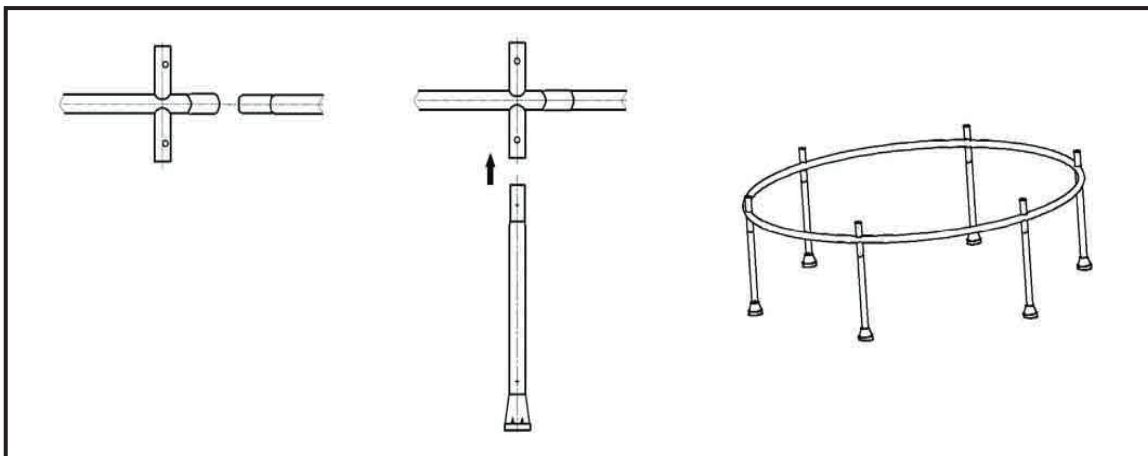

2. Installieren Sie das Beinrohr nacheinander in das Hauptgestell.
3. Wenn der Trampolinrahmen jetzt geöffnet ist und die Sprungmatte in der Mitte des Rahmens herausgenommen wird, beginnen Sie jetzt mit dem Einbau der elastischen Federn. Installieren Sie zwei elastische Federn an zwei Seiten des Rahmens. Installieren Sie die elastische Feder an den beiden anderen Seiten des Rahmens. (Achtung: Installieren Sie die Sprungmatte auf der Basis der untenstehenden Montageanleitung)

**Hinweis: Bitte tragen Sie Handschuhe, wenn Sie die elastischen Federn installieren.**

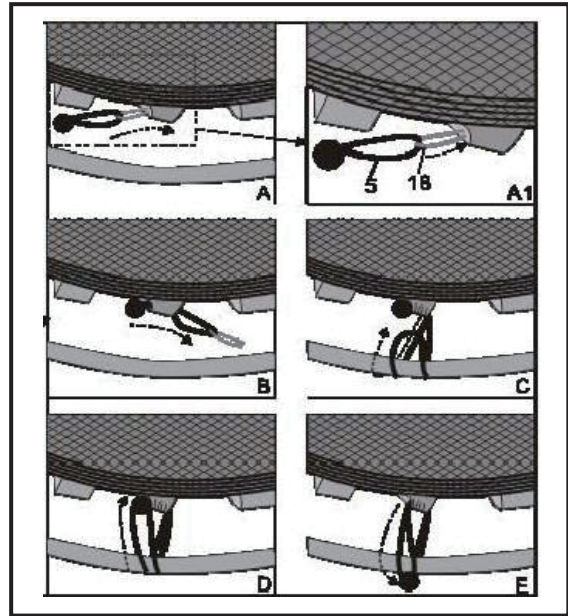
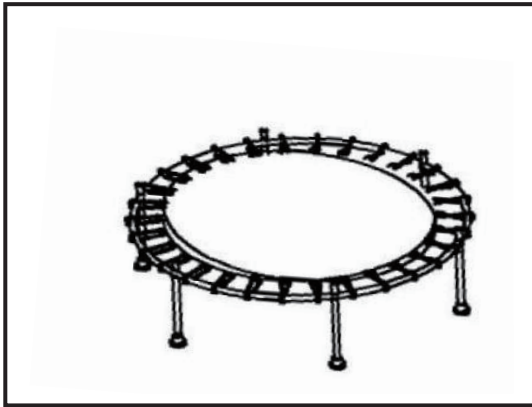

4. Legen Sie das Abdeckpolster auf den Trampolinrahmen. Positionieren Sie jede der 6 Öffnungen in der Polsterabdeckung vorsichtig über den entsprechenden Buchsen der Gehäusestangen.

5. Arbeiten Sie vorsichtig die untere Maschenschürze um den gesamten Umfang des Trampolins herum an der Außenseite der Beine herunter. Richten Sie die an der Unterseite der unteren Maschenschürze angebrachte Öse auf das Loch in der Nähe der Beinbasis aus und befestigen Sie sie mit einer Schraube.

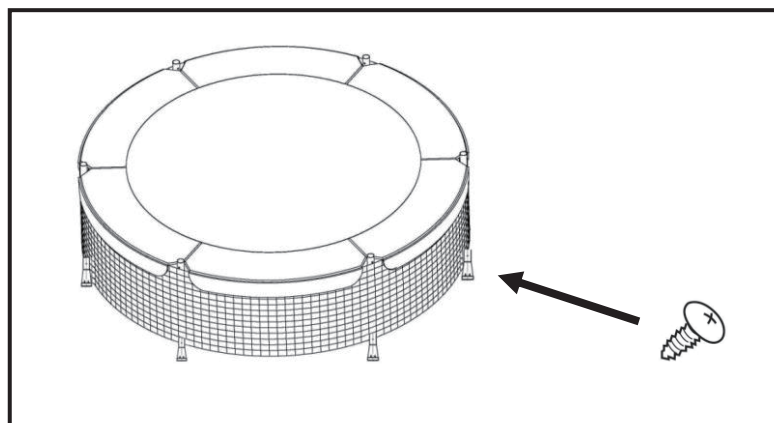

6. Setzen Sie den oberen und den unteren Netzpfeiler getrennt in den Hauptrahmen ein.

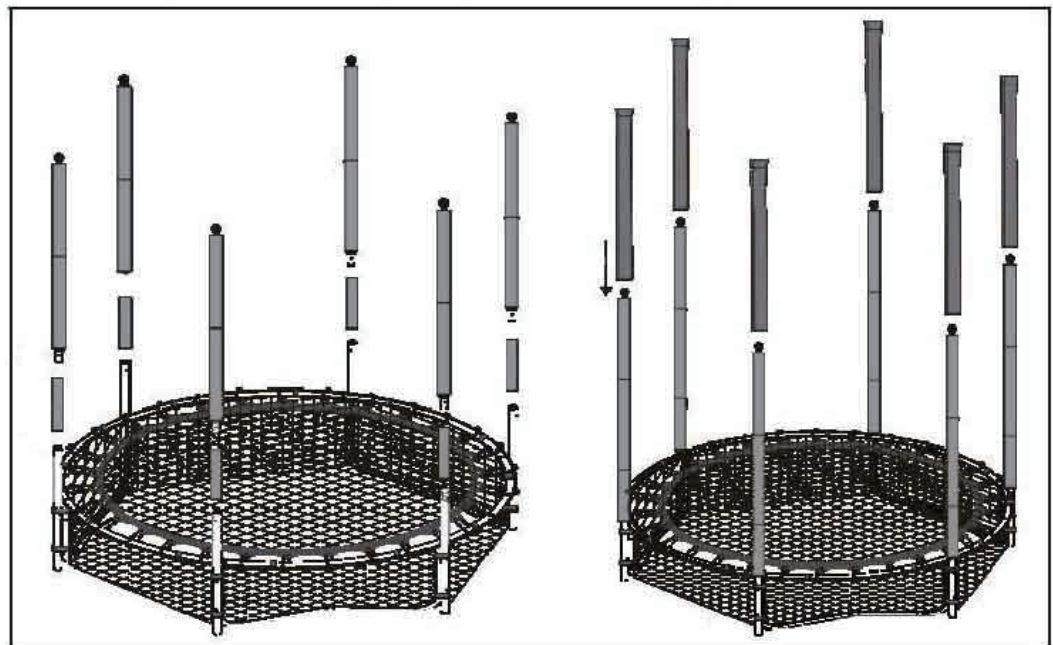

7. Befestigen Sie das Netz von oben nach unten am Hauptgestell mit der Befestigungsschnalle des Netzes am Balkkopf und binden Sie das darunter liegende Gummiband an das darunter liegende Rohr.

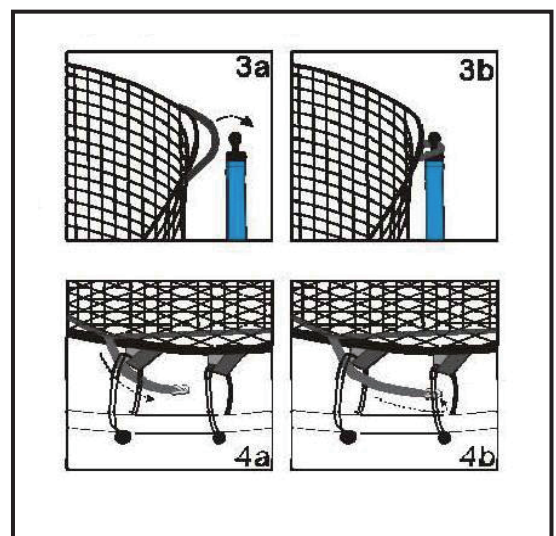
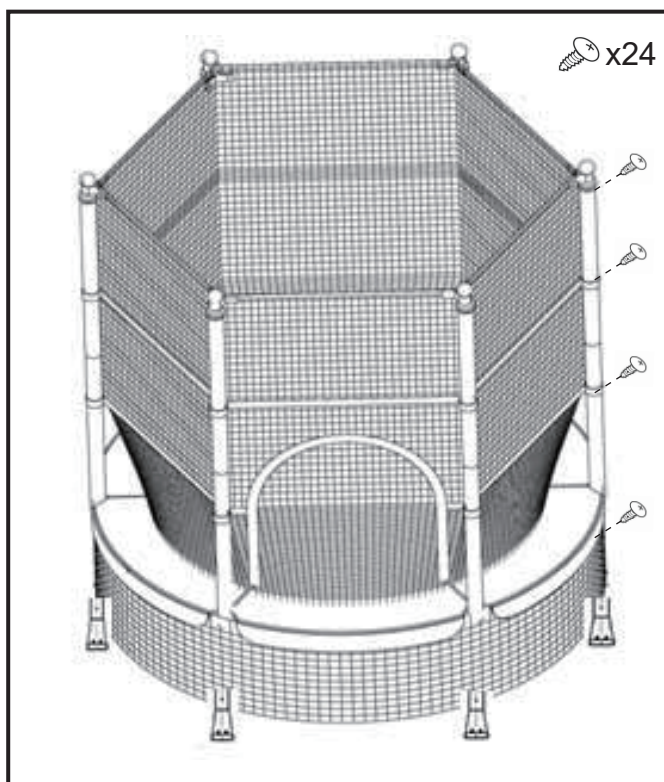





IN230700047V01\_UK\_FR\_ES\_DE\_IT

**342-008\_342-008V01**

IT



UK  
FR  
CE

(55" TRAMPOLINO ROTONDO CON RETE DI SICUREZZA)

IMPORTANTE - CONSERVARE QUESTE INFORMAZIONI  
PER CONSULTARLE IN SEGUITO: LEGGERE ATTENTAMENTE

**ISTRUZIONI DI ASSEMBLAGGIO**

## **ATTENZIONE**

**Installare sempre il trampolino due persone alla volta. Tenere la testa e il viso lontani dalla struttura del trampolino. La mancata osservanza di questa precauzione può causare gravi lesioni alla testa o al viso o provocare altre lesioni gravi. Non siamo responsabili per eventuali lesioni che possono verificarsi durante l'utilizzo del trampolino.**

### Indice dei contenuti

Lista Parti.....	3, 4
Note & Avvertenze.....	4
Istruzioni di Montaggio.....	4, 5, 6

## Teilliste

Numero Ref.	Numero Parte	Descrizione	Unita'
1	TR01	Struttura trampolino	6
2	TR02	Gambe trampolino	6
3	TR03	Materasso elastico	1
4	TR04	Rondelle elastiche	30
5	TR05	Parte superiore palo rete	6
6	TR06	Parte inferiore palo rete	6
7	TR07	Rete	1
8	TR08	Cuscinetti protettivi	1
9	TR09	Viti	30
10	TR10	Chiave	1
11	TR11	Manuale	1



Tr01 x 6pz



Tr02 x 6pz

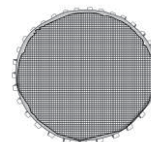

Tr03 x 1pz



Tr04 x 30pz



Tr05 x 6 pz

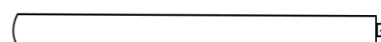

Tr06 x 6pz

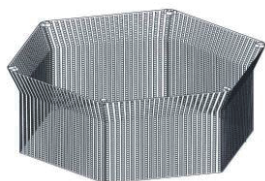

Tr07 x 1pz

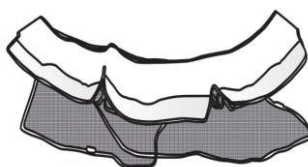

Tr08 x 1pz



Tr09x 30pz



Tr10 x 1pz



Tr11 x 1pz

## Note & Avvertenze

1. Questo prodotto non deve essere utilizzato da persone che pesano più di 45 kg.
2. Le gambe del trampolino vanno installate saldamente, assicurarsi di non impigliare le dita o la mano durante l'assemblaggio.
3. Le molle elastiche possono essere rigide nelle prime fasi di utilizzo del trampolino ma si allenteranno nel tempo. Fare attenzione mentre si installa il trampolino e non procurarsi lesioni.
4. Utilizzare il trampolino rialzato su un tappeto o su un pavimento che non sia scivoloso in modo che esso non scivoli quando in uso.

## Istruzioni di Montaggio

1. Posizionare tutte le parti del trampolino sul pavimento, connettere i 6 pezzi del telaio del trampolino.

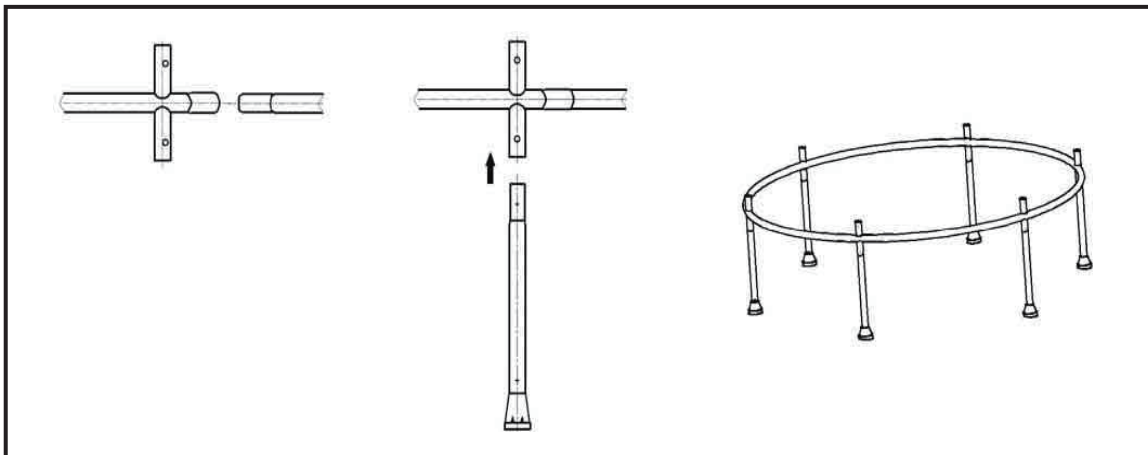

1. Installare a turno i tubi delle gambe nella struttura principale.
2. Con il telaio del trampolino ora aperto, estrarre il materasso elastico e metterlo al centro del telaio, iniziare installando le molle elastiche, due molle elastiche su due lati del telaio, installare poi una molla elastica su altri due lati del telaio, e continuare fissando le corde come mostrato. (attenzione: installazione della base necessaria per il materasso elastico spiegata nelle istruzioni di montaggio seguenti)

Nota: indossare i guanti quando si installano le molle elastiche.

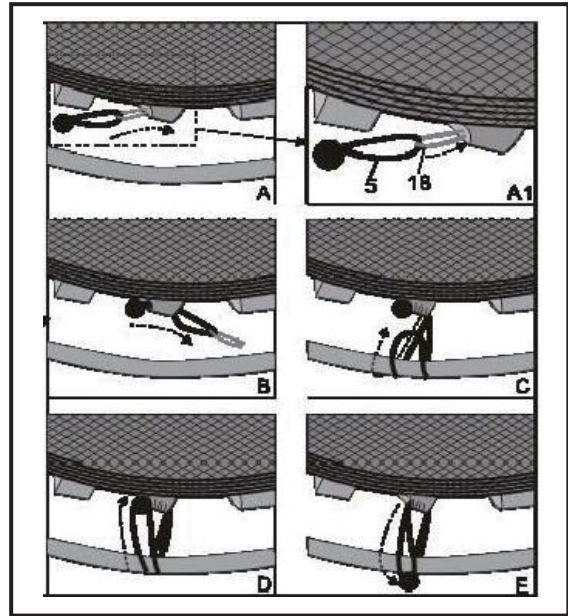
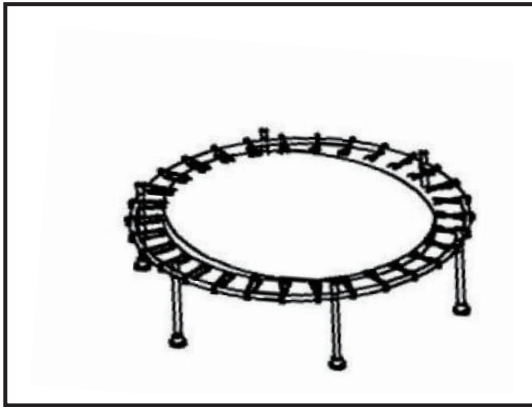

4. Posizionare l'imbottitura protettiva sulla struttura del trampolino, posizionare con attenzione ciascuna delle 6 aperture nell'apposita parte dell'imbottitura sulle corrispondenti prese dei poli.

5. Fissare con cura la maglia della rete inferiore verso il basso, lungo tutto il perimetro del trampolino, all'esterno delle gambe. Allineare il gommino nella parte inferiore rete inferiore con il foro vicino alla base della gamba e fissarlo con la vite.

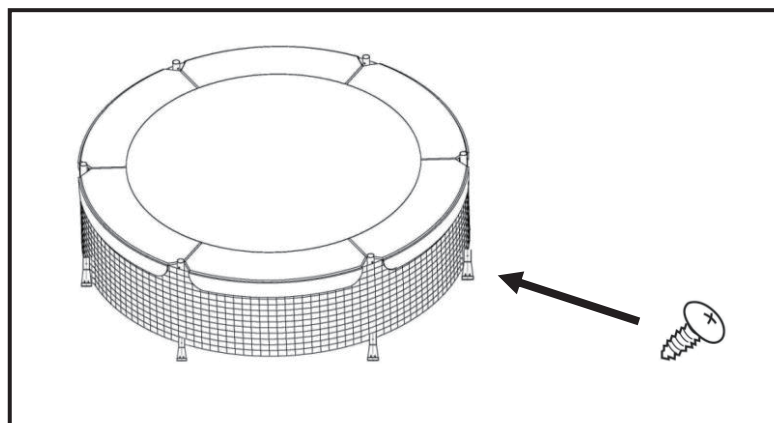

6. Inserire a turno il palo della rete superiore e il palo della rete inferiore nella struttura principale.

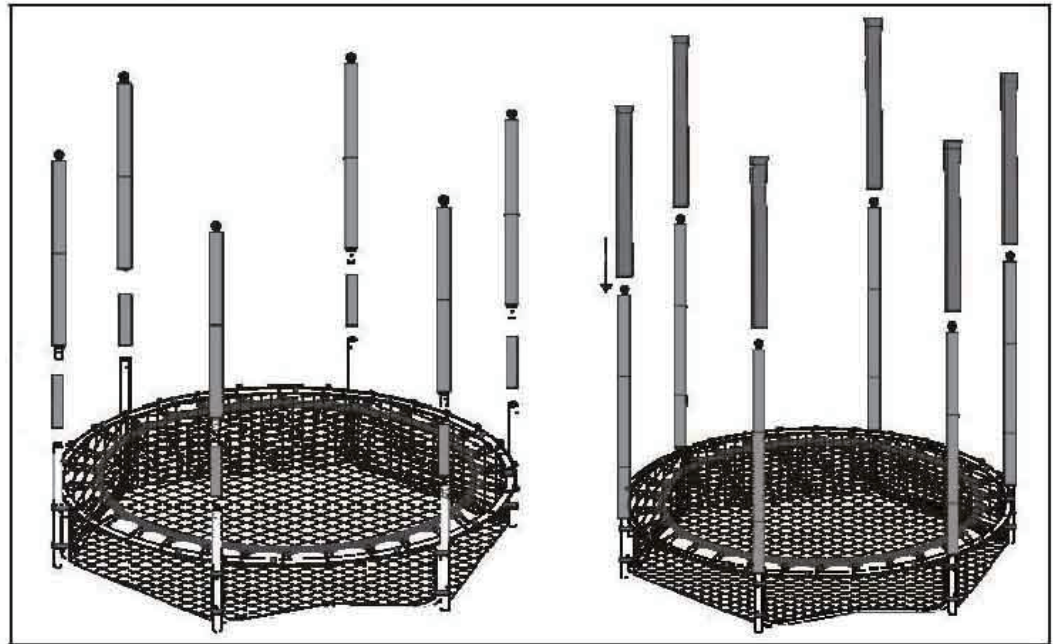

7. Fissare la rete dall'alto verso il basso alla struttura principale con la fibbia di fissaggio della rete che si trova sulla testa a sfera e legare la cinghia elastica al tubo sottostante.

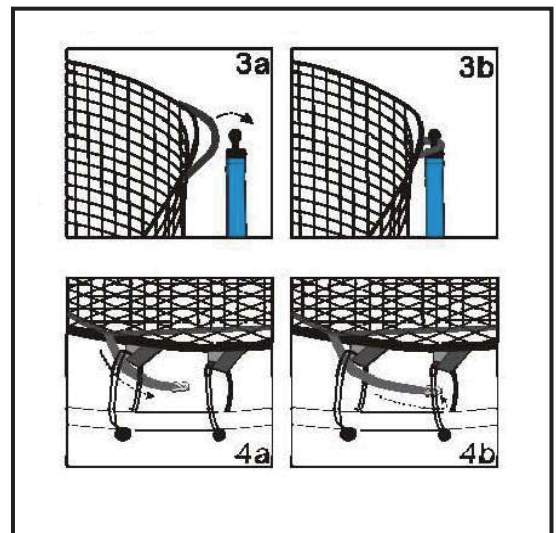
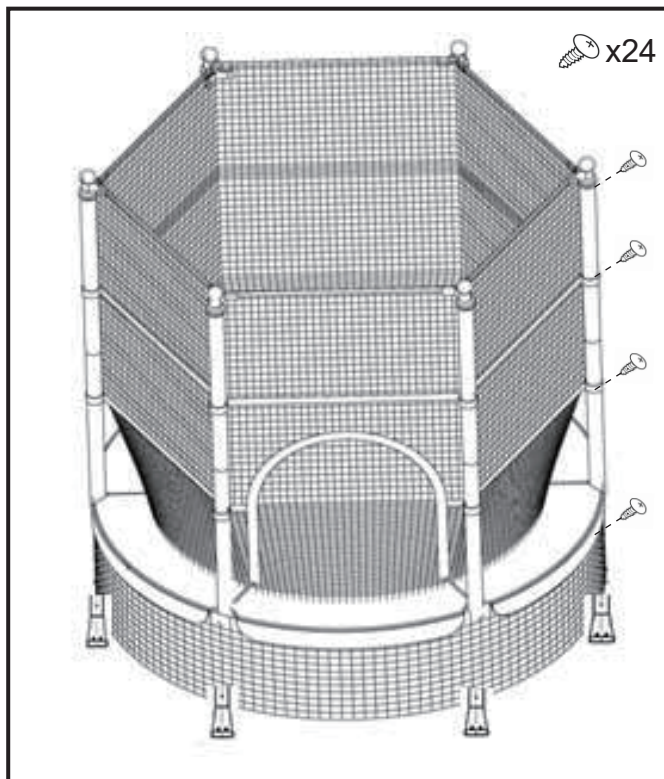

**UK**

If you have any questions, please contact our customer care center.

Our contact details are below:



0044-800-240-4004



enquiries@mhstar.co.uk

IMPORTER ADDRESS:

MH STAR UK LTD

Unit 27, Perivale Park,  
Horsenden lane South

Perivale, UB6 7RH

MADE IN CHINA

**ES**

Si tiene alguna pregunta, comuníquese con nuestro Centro de Atención al Cliente. Nuestros datos de contacto son los siguientes:



0034-931294512



atencioncliente@aosom.es

IMPORTADOR:

SPANISH AOSOM, S.L.

C/ ROC GROS, N° 15. 08550, ELS HOSTALETS DE  
BALENYÀ, SPAIN.

B66295775

WWW.AOSOM.ES

ATENCIONCLIENTE@AOSOM.ES

TEL: 931294512

HECHO EN CHINA

**FR**

Si vous avez la moindre question, veuillez contacter notre centre d'assistance à la clientèle.

Nos coordonnées sont les suivantes:



0033-1-84166106



aosom@mhfrance.fr

Importé par:

MH France

2, rue Maurice Hartmann

92130 Issy-les-Moulineaux

France

Fabriqué en Chine

**PT**

Se tiver alguma dúvida, por favor contacte o nosso Centro de Atendimento ao Cliente. Os nossos dados de contacto são os seguintes:



0034-931294512



info@aosom.pt.

IMPORTADOR:

SPANISH AOSOM, S.L

C.ROC GROS N.15, 08550. ELS HOSTALETS DE BALENYÀ

TEL: 931294512 (SEG-SEX DAS 7:30H ÀS 16:30H)

INFO@AOSOM.PT

WWW.AOSOM.PT

**DE**

Wenn Sie Fragen haben, wenden Sie sich bitte an unser Kundendienstzentrum.

Unsere Kontaktdaten stehen unten:



0049-0(40)-88307530



service@aosom.de

ADRESSE DES IMPORTEURE:

MH Handel GmbH

Wendenstraße 309

D-20537 Hamburg

Germany

IN CHINA HERGESTELLT

**IT**

In caso di dubbio, si prega di contattare il nostro centro assistenza clienti.

I nostri dettagli di contatto sono di seguito:



0039-0249471447



clienti@aosom.it

IMPORTATO DA:

AOSOM Italy srl

Centro Direzionale Milanofiori

Strada 1 Palazzo F1

20057 Assago (MI)

P.I.: 08567220960

FATTO IN CINA