



IN230800177V01_UK

845-486V71



Danger zone



Wear protective goggles



Use protective gloves



Escape way



Wear hearing protectors



Do not expose to precipitation



Warning!



Tree fall direction



Read the operating instruction



Noise - L_{WA} power



Second class of insulation



Remove plug from the mains immediately if the cable is damaged or cut



EN_IMPORTANT, RETAIN FOR FUTURE REFERENCE: READ CAREFULLY.

FR_IMPORTANT: A LIRE ATTENTIVEMENT ET À CONSERVER POUR CONSULTATION ULTÉRIEURE.

ES_IMPORTANTE, LEA Y GUARDE PARA FUTURAS REFERENCIAS.

PT_IMPORTANTE, RETER PARA REFERÊNCIA FUTURA: LEIA ATENTAMENTE.

DE_WICHTIG! SORGFÄLTIG LESEN UND FÜR SPÄTER NACHSCHLAGEN AUFBEWAHREN.

IT_IMPORTANTE! CONSERVARE IL PRESENTE MANUALE PER FUTURO RIFERIMENTO E LEGGERLO ATTENTAMENTE.

EN

Dear customer,

Thank you for purchasing this product. So that your appliance serves you well, please read all the instructions in this user's manual. If you have any questions, please contact our customer care center, Our contact details are below:

FR

Cher client,

Nous vous remercions d'avoir acheté ce produit. Afin que vous puissiez profiter pleinement de votre appareil, veuillez lire toutes les instructions de ce manuel d'utilisation. Si vous avez la moindre question, veuillez contacter notre centre d'assistance à la clientèle, Nos coordonnées sont les suivantes:

DE

Sehr geehrter Kunde,

Vielen Dank, dass Sie dieses Produkt erworben haben. Damit Ihr Gerät Ihnen gute Dienste leistet, lesen Sie bitte alle Hinweise in diesem Benutzerhandbuch. Wenn Sie Fragen haben, wenden Sie sich bitte an unser Kundendienstzentrum, Unsere Kontaktdaten stehen unten:

ES

Queridos clientes,

Gracias por comprar este producto. Para que su electrodoméstico le sirva mejor, lea todas las instrucciones de este manual del usuario. Si tiene alguna pregunta, comuníquese con nuestro Centro de Atención al Cliente, Nuestros datos de contacto son los siguientes:

PT



Caros clientes,

Obrigado por adquirir este produto. Para que o seu aparelho o sirva melhor, leia todas as instruções deste manual do utilizador. Se tiver alguma dúvida, por favor contacte o nosso Centro de Atendimento ao Cliente, Os nossos dados de contacto são os seguintes:

IT

Caro Cliente,

Grazie per aver acquistato questo prodotto. Per servirti meglio con questo apparecchio ti prego di leggere tutte le istruzioni in presente manuale utente. In caso di dubbio, si prega di contattare il nostro centro assistenza clienti, I nostri dettagli di contatto sono di seguito:

Country	 Phone	 Email
US	001-877-644-9366	customerservice@aosom.com
CA	416-792-6088	customerservice@aosom.ca
UK	0044-800-240-4004	enquiries@mhstar.co.uk
DE	0049-0(40)-88307530	service@aosom.de
FR	0033-1-84166106	aosom@mhfrance.fr
ES	0034-931294512	atencioncliente@aosom.es
PT	0034-931294512	info@aosom.pt
IT	0039-0249471447	clienti@aosom.it

Whole Machine

① x 1



Side Cover

② x 1



Guides

③ x 1



Chain

④ x 1



Knife Protector

⑤ x 1

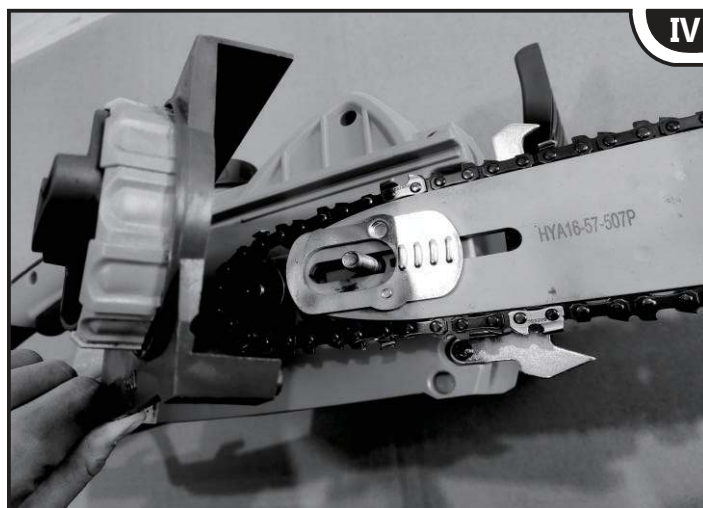
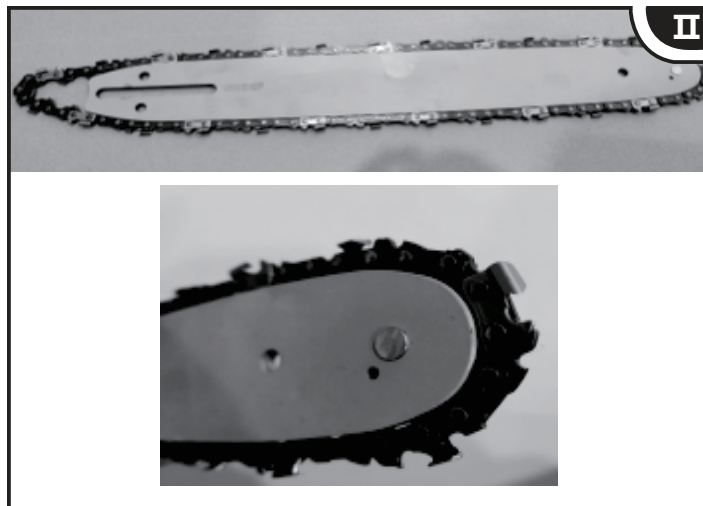

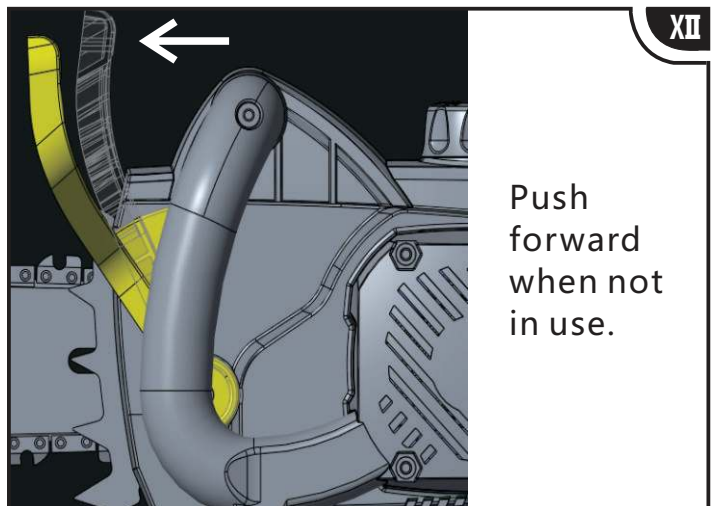
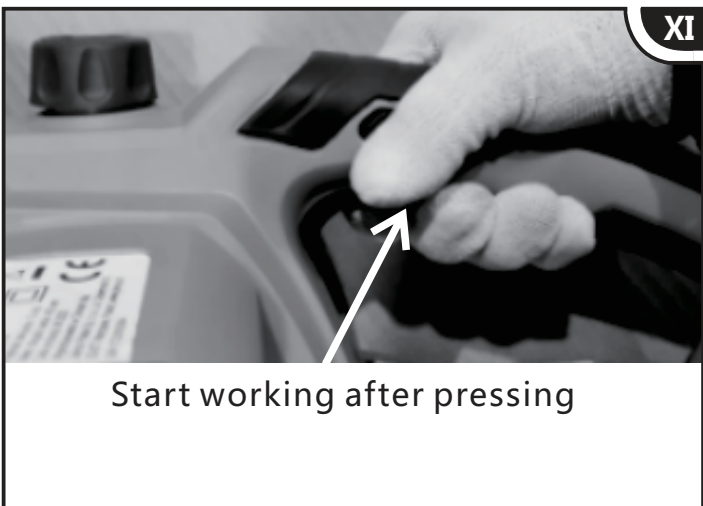
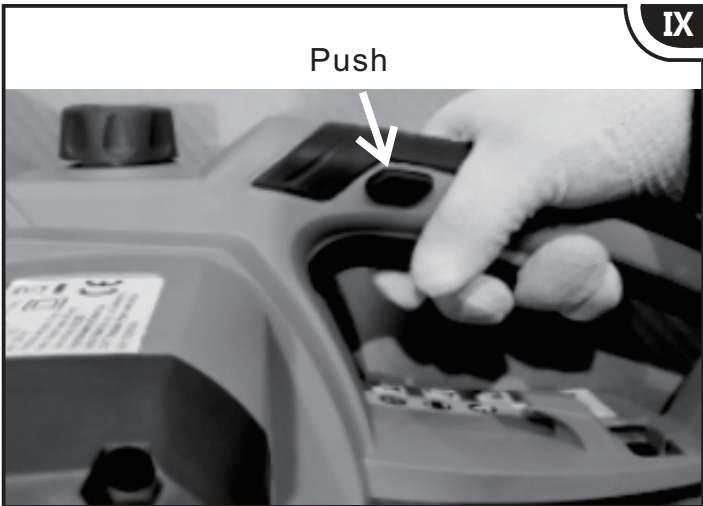
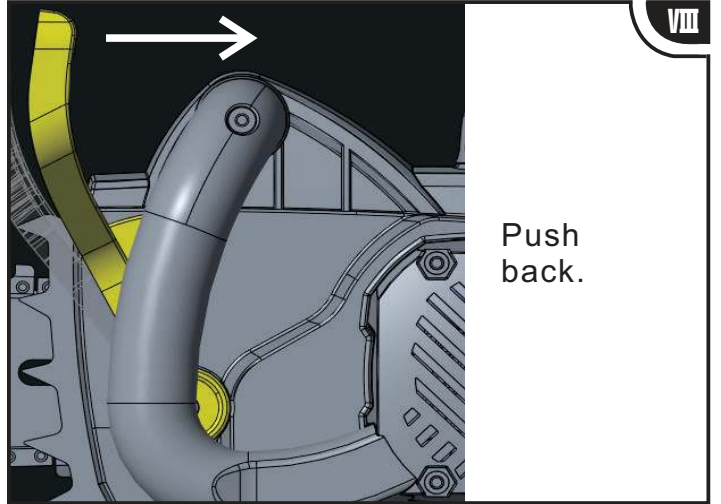
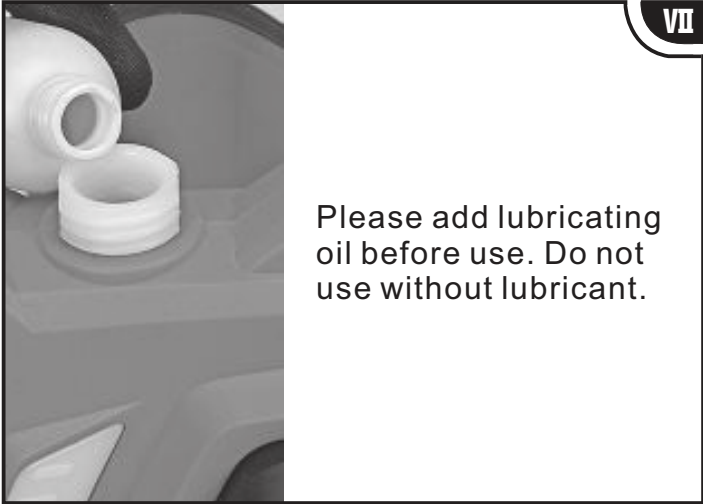
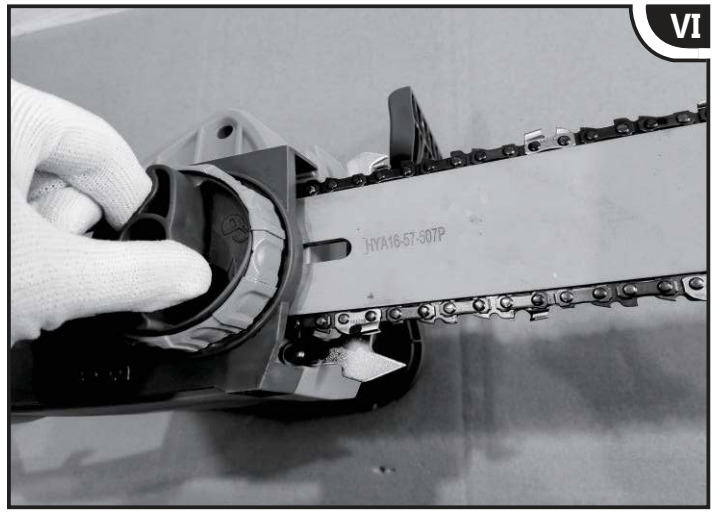
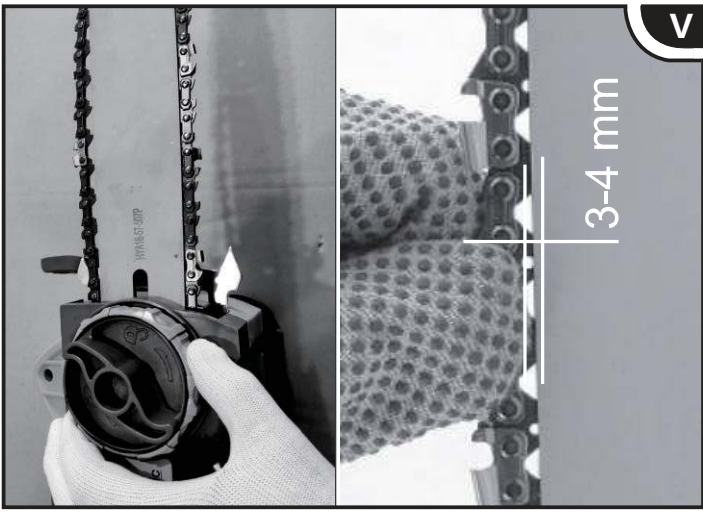

XIII

Protect the knife set when not in use.

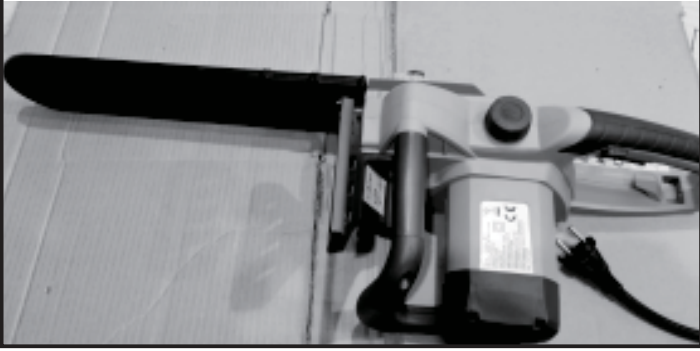
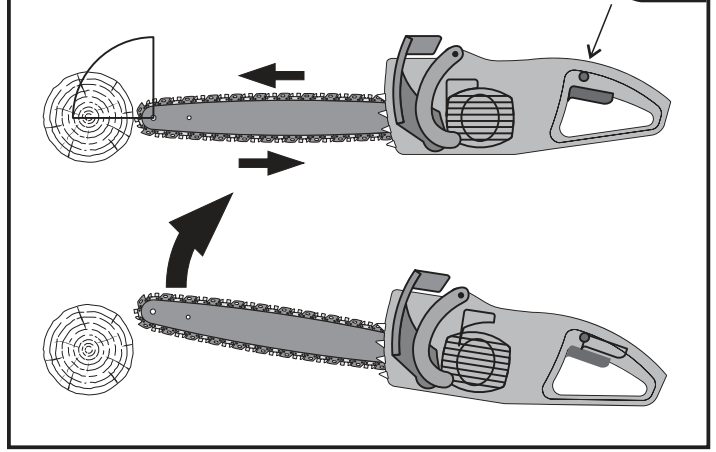
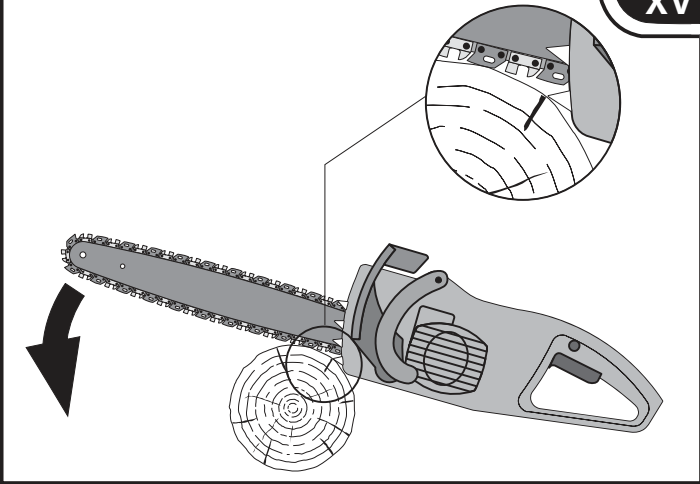
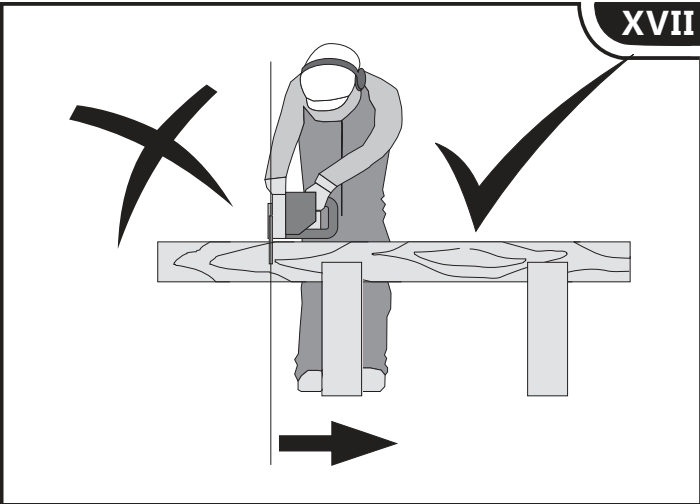
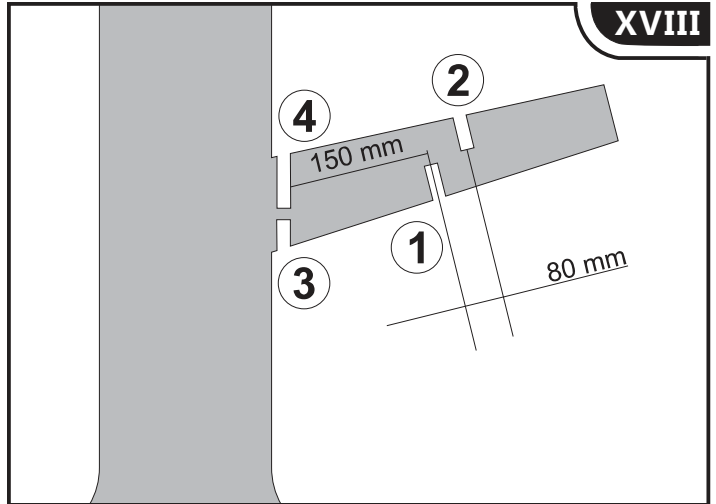
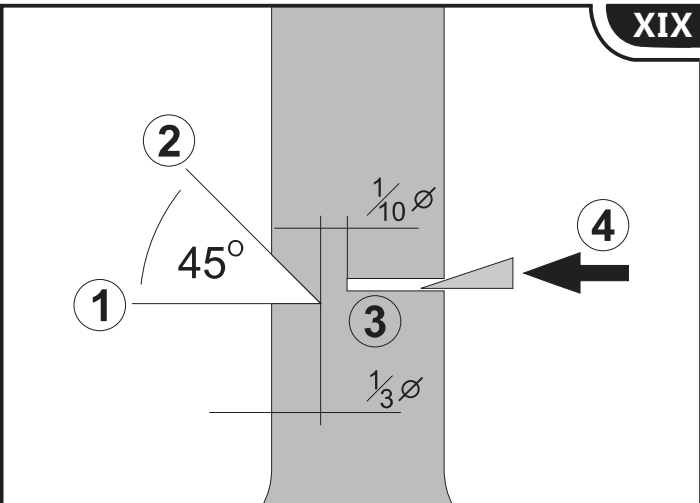
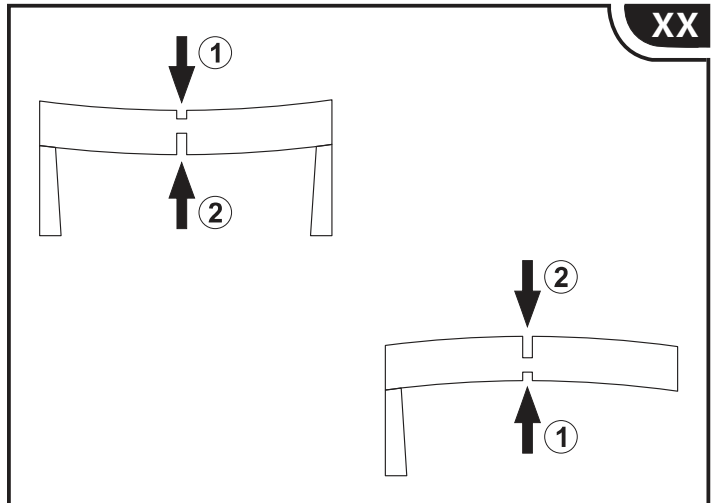
**XIV****XV****XVI****XVII****XVIII****XIX****XX**

PRODUCT CHARACTERISTICS

The chainsaw is only intended for cutting wood. The chainsaw electric drive allows it to be used under a canopy or near buildings.

It can be used for cutting trees, but due to the hazard, it is required that an experienced user performs the cutting operation. Be-cause a correct, reliable, and safe operation of the device depends on proper use, follow the guidelines below.

Read this entire instructions manual before the fi rst use of the tool and keep it for future reference.

The supplier shall not be held liable for any damage or injury resulting from improper use of the device, failure to observe the safety regulations and recommendations of this manual. Use of the tool for purposes other than those for which it was intended shall cause the loss of the user's rights to a warranty and statutory warranty.

PRODUCT EQUIPMENT

The chainsaw is supplied complete but requires assembly before fi rst use.

The chainsaw includes:

- chain guide bar
- cutting chain
- guide bar guard

TECHNICAL DATA

Parameter	Unit	Value
Catalogue No.		
Rated voltage	[V~]	230
Rated frequency	[Hz]	50
Rated power	[W]	1600
Chain speed	[m/s]	13
Guide bar length	[mm / "]	400/16
Chain scale	[mm]	8.255
Chain spacing	[mm]	19
Chain type		
Chain guide bar type		
Guide link width	[mm / "]	1.47/0.058
IEC protection class		II
Oil tank capacity	[ml]	110
Weight (without the guide bar and chain)	[kg]	2.8
Noise level		
- L _{PA} (pressure)	[dB] (A)	90.2 ± 3.0
- L _{WA} (power)	[dB] (A)	103.2 ± 3.0
Vibration — main handle/additional handle	[m/s ²]	8.393 ± 1.5 / 6.002 ± 1.5
Protection rating		IPX0

GENERAL WARNINGS FOR THE SAFETY OF MACHINES

Warning! Read all safety warnings, illustrations and specifications provided with this machine. Failure to do so may result in electric shock, fire or serious injury.

Keep all warnings and instructions for future reference.

The term “machine” used in warnings applies to all machines driven by power both wired and wireless.

Workplace safety

Keep the workplace well-lit and clean. Disorder and poor lighting can be causes of accidents. Do not work with machines in an environment with an increased risk of explosion, containing flammable liquids, gases or vapors. Power machines generate sparks that can ignite dust or fumes.

Children and third persons should not be allowed to enter the workplace. Loss of concentration can result in loss of control.

Electrical safety

The plug of the electric cable must match the power socket. You must not modify the plug in any way. Do not use any plug adapters with earthed machines. An unmodified plug that fits the outlet reduces the risk of electric shock.

Avoid contact with earthed surfaces such as pipes, radiators and coolers. Grounding the body increases the risk of electric shock.

Do not expose machines to contact with atmospheric precipitation or moisture. Water and moisture that gets inside the machine increases the risk of electric shock.

Do not overload the power cable. Do not use the power cord to carry, pull or unplug the power plug from the power outlet.

Avoid contact of the power cable with heat, oils, sharp edges and moving parts. Damage or entanglement of the power cord increases the risk of electric shock.

In the case of working outside closed rooms, use extension cords intended for work outside closed rooms. The use of an extension cord adapted for outdoor use reduces the risk of electric shock.

When using a machine in a humid environment is unavoidable as a protection against supply voltage use a residual current device (RCD). The use of RCD reduces the risk of electric shock.

Personal safety

Stay alert, pay attention to what you do and keep common sense while working with the machine. Do not use a machine when you are tired or under the influence of alcohol or medication. Even a moment of inattention while working can lead to serious personal injury.

Use personal protective equipment. Always wear eye protection. The use of personal protective equipment such as dust masks, anti-slip safety shoes, helmets and hearing protection reduce the risk of serious personal injury.

Prevent accidental operation. Make sure that the electric switch is in the “off” position before connecting to the power supply and / or battery, lifting or moving the machine. Moving the machine with the finger on the switch or powering the machine, when the switch is in the “on” position can lead to serious injuries.

Before turning on the machine remove any keys and other tools that were used to adjust it. The key left on the rotating parts of the machine can lead to serious injuries.

Do not reach and do not lean too far. Keep the right attitude and balance all the time. This will allow easier control over the machine in case of unexpected work situations.

Dress accordingly. Do not wear loose clothing or jewelry. Keep your hair and clothing away from moving parts of the machine. Loose clothing, jewelry or long hair can be caught by moving parts.

If the devices are fitted for the connection of dust extraction or dust collection, make sure that they are connected and used properly. The use of dust extraction reduces the risk of dust hazards.

Do not let the experience acquired from frequent use of the machine resulted in carelessness and ignoring safety rules.

Carefree action can cause serious injuries in a fraction of a second.

Use and care of the machine

Do not overload the machine. Use the machine appropriate for the selected application. The right machine will provide a better and safer job if used according to the designed load.

Do not use the machine, if the electric switch does not allow switching on and off. Machine, which cannot be controlled by means of a power switch is dangerous and must be returned for repair.

Disconnect the plug from the power socket and / or remove the battery if it is detachable from the machine before adjusting, changing accessories or storing the machine. Such preventive measures will allow you to avoid accidentally turning on the power machine.

Keep the tool out of the reach of children, do not let people who do not know how to operate the machine or these instructions use a machine. Machines are dangerous in the hands of untrained users.

Maintain machines and accessories. Check the machine for mismatches or jams of moving parts, damage to parts and any other conditions that may affect the operation of the power machine. Damage must be repaired before using the machine. Many accidents are caused by incorrectly maintained machines.

Keep cutting tools sharp and clean. Properly maintained cutting tools with sharp edges are less prone to jamming and are easier to control when working.

Use power machines, accessories and inserted tools etc. in accordance with these instructions, taking into account the type and conditions of work. The use of tools for work other than designed is likely to result in a dangerous situation.

Handles and gripping surfaces must be dry, clean and free from oil and grease. Slippery handles and gripping surfaces do not allow for safe operation and control of the machine in dangerous situations.

Repairs

Repair the machine only in authorized facilities using only original spare parts. This ensures proper operation safety of the power tool.

ADDITIONAL SAFETY INSTRUCTIONS

While working with the chainsaw, keep all parts of the body away from the chain. Make sure that the chain is not in contact with anything before starting the chainsaw. A moment's distraction while working with a chainsaw can lead to cloth or body part entangling in the chainsaw chain.

Always hold the chainsaw with your right hand by the back handle and with your left hand by the front handle. Holding the chainsaw in the opposite way should never happen, as it increases the risk of injury.

Wear safety glasses and hearing protectors. It is also recommended to use head, hands, legs, and foot protections. Appropriate protective clothing reduces the risk of injury due to contact with waste or accidental contact with the chain.

Do not operate the chainsaw while on a tree. Working with the chainsaw while on the tree may result in injuries.

Always maintain a proper posture and work with the chainsaw standing on a still, safe, and level surface. A slippery or unstable surface, e.g., a ladder, may result in a loss of balance or control of the chainsaw.

Exercise caution in terms of a kickback when cutting a tensioned branch. If the tension accumulated in the wood fibres is released, the branch may strike the operator or make him/her lose control of the chainsaw.

Take special care when cutting shrubs and young trees. Slim material can nip the chain and push the chainsaw towards the operator or unbalance him/her.

Handle the chainsaw by the front handle, turned off and away from the body. Always put on the chain guide bar guard when transporting or storing the chainsaw. Correct holding of the chainsaw reduces the likelihood of accidental contact with moving parts of the chainsaw.

Observe the instructions for lubricating, tensioning the chain, and changing accessories. An improperly tensioned or lubricated chain can break and increase the chance of kickback towards the operator.

Keep handles dry, clean, and free of grease and oil. The greasy or grease-coated handles are slippery and cause control loss of the chainsaw.

Cut wood only. The use of the chainsaw for other purposes than that intended is not allowed.

For example: do not cut plastic, concrete, or non-wooden construction materials. Using the chainsaw for works other than that intended may result in dangerous situations. When working, hold the chainsaw by the insulated handles, as the chain may come into contact with a live wire, including its power cord in case of mains-powered saws. When the chain is in contact with a live wire, this may cause the chainsaw's metal parts to become live, leading to electrocution to the operator.

Causes and prevention of kickback towards the operator.

A kickback towards the operator may occur when the guide bar's end is in contact with an object or the cut wood jams the chainsaw in the kerf. In some cases, contact between the end of a guide bar and an object can cause a violent reaction driving the guide bar up and towards the operator. Jam in the guide bar upper edge kerf can suddenly point the guide bar towards the operator.

These reactions can result in a loss of control of the chainsaw, leading to serious injuries. Do not rely only on safety elements built in the chainsaw. The chainsaw operator should take some steps to prevent accidents and injuries during work.

A kickback towards the operator is the result of improper use or incorrect operating procedures or conditions. This can be avoided by taking the appropriate precautions listed below:

Keep a firm grip of both hands with thumbs and fingers closing around the chainsaw handles. The position of the body and shoulders should allow withstanding forces arising during the kickback. If appropriate precautions are taken, the kickback forces can be controlled by the operator. Do not allow the chainsaw to move freely.

Do not reach too far and cut above shoulder height. This will help prevent unintentional contact with the end of the guide bar and allow better control of the chainsaw in unexpected situations.

Use guide bar and chain replacements only as specified by the manufacturer. Incorrect replacement of the guide bar and chain may cause chain breakage or kickback.

Observe the instructions given by the manufacturer regarding the chain sharpening and maintenance. Reducing the depth of the chain guide bar groove can lead to an increased probability of kickback.

It is forbidden to expose the chainsaw to precipitation and use it in an atmosphere of increased humidity. It is also forbidden to use the chainsaw in an atmosphere with an increased risk of fire or explosion.

Avoid contact with grounded, conductive, and non-insulated objects such as pipes, radiators, or refrigerators during operation.

When not in use, store the chainsaw in a dry and closed room inaccessible to unauthorised persons.

Use the cutting chain adapted to the given load. Do not use cutting chains designed for light or heavy-duty work.

Always wear protective gloves when replacing, repairing, and adjusting the cutting chain.

Make sure that the chainsaw has been disconnected from the power supply during transport.

Disconnect the mains-powered chainsaws from the socket. In the case of the battery-powered chainsaws, disconnect their battery. A guard must be fitted on the cutting chain guide bar. Handle the chainsaw with the guide bar pointing back.

Do not handle the mains-powered chainsaw by its power cord. Do not disconnect the plug from the socket by pulling the power cord.

Avoid accidental starting of the chainsaw. When handling the chainsaw connected to the mains or with the battery connected, keep your fingers away from the power switch.

Always wear appropriate protective clothing that adheres to the body.

Operate the chainsaw holding it with both hands. When working, secure loose pieces of wood so that they cannot move, for example, by placing them in a saw-horse. Avoid cutting wood that lays on the ground. Avoid processing wood that is not protected against movement during cutting.

Do not hold the chainsaw above your arms during operation. Do not operate the chainsaw while standing on the ladder. During work, adopt such a posture to eliminate the need to extend the hands to the full length.

Keep the chain clean. The chain must be sharpened and lubricated. This will ensure more efficient and safer work. The chain can be sharpened in a specialised service centre. Check the

condition of the chain before each use. In the event of cracks, broken teeth, or any other damage, replace the chain with a new one before starting work.

In case of finding any damaged or broken chainsaw parts, stop working or do not start working. It is essential to replace damaged parts before starting work.

Use the chainsaw as intended. The chainsaw is designed only for cutting wood. When working, watch out for metal elements or stones that may be in the processed wood.

Use original spare parts only. Failure to use original spare parts may increase the risk of failure and lead to injuries.

The chainsaw should be repaired only in service centres authorised by the manufacturer using original spare parts. This will minimise the risk of accidents and damage to the equipment.

PRODUCT OPERATION

Preparing the chainsaw for operation **Caution!** Unplug the chainsaw from the power supply before performing any assembly and adjustment work. Disconnect the mains-powered chainsaws from the socket. In the case of the battery-powered chainsaws, disconnect their battery.

Mount the guide bar and cutting chain before first use.

Due to the sharp edges of the chain, perform the assembly wearing protective gloves.

Unscrew the locking knob or nut so that the entire side panel can be removed.

Turn the chain tension knob so that the guide bar is in the maximum back position — this will facilitate the chain installation.

Mount the guide bar and chain as shown in the picture (II).

Make sure that the chain and guide bar are fitted in the correct direction. The shape and direction of the links visible on the chainsaw housing should correspond to the chain's shape and direction. If there is a visible movement direction indication on the chain

links, it should have the same direction as the indication on the housing and guide bar.

Do not tension the chain yet, but make sure that the chain fits the guide bar slot and the teeth on the drive wheel. Mount the side panel and tighten the locking knob. However, do it so as not to block the possibility of the guide bar movement. Adjust the chain tension by turning the chain tension knob. Tighten the locking knob. Check the chain tension. To do this, set the chainsaw down and lift it by holding the middle part of the chain (III). During this test, the chain should lift above guide bar by 3 to 4 mm in the spot where it is held. If the chain is tightened too tight or too loose, loosen the locking knob a little and reset the chain tension.

The chain tension should also be checked every 10 minutes of operation.

Check the technical condition of the chainsaw before connecting it to the power supply. If any damage is detected, it is forbidden to connect it to the power supply before removing the damage.

In case the chainsaw must be powered with one-phase alternating current with voltage 230 V and frequency 50 Hz, the mains socket powering the chainsaw should be protected with a ground-fault circuit interrupter with a tripping current 30 mA or less.

Oil topping-up (IV)

Caution! Unplug the chainsaw from the power supply before performing any assembly and adjustment work. Disconnect the mains-powered chainsaws from the socket. In the case of the battery-powered chainsaws, disconnect their battery.

For lubricating the chain and chainsaw mechanisms, use only oil intended for such purposes. It is forbidden to use worn-out motor oil. It does not fulfil its purpose, which can lead to damage to the chainsaw mechanism.

Make sure that there is lubricating oil in the tank. Place the chainsaw on the horizontal surface and check the oil indicator. The oil level cannot be lower than the minimum indication. If there is no such indicator, the lower edge of the oil level indicator should be taken as the reference level.

It is forbidden to use the chainsaw with the empty oil tank. This can damage the chain, guide bar, and mechanisms of the chainsaw. It is recommended to start and operate the chainsaw at least 3 meters from the place where the oil topping-up procedure was performed. Perform oil topping-up away from fire and heat sources.

To top up the oil, unscrew the oil tank cap, pour the oil inside the tank so the oil level levels out with a mark indicating the maximum oil level or upper edge of the oil level indicator, then screw the tank cap firmly and securely. In case of spilling the oil, thoroughly wash off any

debris before connecting the chainsaw to the power supply.

Preparing the workplace

Before cutting with the chainsaw, properly prepare the workplace to minimise the risks associated with the chainsaw's operation.

Make sure that only authorised persons are present at the workplace.

In the case of tree felling, danger zones and escape routes should be designated. A zone with a radius of 180 O around the planned tree fall plane and a zone with a radius of 90 O in the opposite direction to the planned tree fall plane are treated as danger zones.

The remaining zones form escape routes (V). Remember that a falling tree can also overturn other trees. Therefore, the next workstation must not be closer than 2,5 x the height of the felled tree (VI).

Ensure good visibility from the workplace; that is why take special care when cutting trees in difficult terrain conditions, e.g., mountains.

It is forbidden to start work during precipitation and in case of high air humidity, e.g., fog.

Wear protective clothing and personal protective equipment.

Before starting cutting, perform a trial wood cut in safe conditions, e.g., cutting wood placed on the saw-horse.

Avoid cutting wires, young trees, and wooden beams.

Do not stand on cut wood.

Connecting the chainsaw to the power supply

Plug the power cord plug into an extension cord and the cord into the mains socket.

Starting the chainsaw

Make sure that the kickback brake is in the rear position.

Remove the guard from the guide bar and chain.

Grasp the front handle with your left hand and the back handle with your right hand.

Make sure that the guide bar and chain do not come into contact with any object or surface.

Press the power switch lock button on the handle with your thumb.

Press and hold the power switch in this position. The lock button can be released.

Before cutting, wait until the motor is at full speed and make sure that the chain runs smoothly along the guide bar. If you hear any suspicious sounds or vibration, turn the chainsaw off immediately by releasing the power switch.

The chainsaw is turned off by releasing the power switch.

It is forbidden to turn the chainsaw off by applying the kickback brake.

Unplug the chainsaw from the mains and proceed with maintenance once the chain has stopped.

Working with the chainsaw

Persons who intend to work with a chainsaw for the first time should seek advice on work and safety from a qualified chainsaw operator before starting work. The first works with the chainsaw should consist of cutting the prepared logs placed on the saw-horse.

During work, observe the basic occupational safety principles. Consider also the possibility of kickback in the operator's direction.

The chainsaw may kickback in the operator's direction when the cutting chain encounters resistance.

To reduce this risk:

Pay attention to the placement of the guide bar top when cutting. It is forbidden to cut with the upper quarter of the guide bar top (VII).

Cut only with the chain which moves along the bottom part of the guide bar. When cutting wood, the lower bumper tooth can be used as a hook for the chainsaw's axis of rotation (VIII). Only apply the started chainsaw to the wood to be cut. Do not start the chainsaw after having applied it to the wood being processed.

When working, do not lift the chainsaw to arm height or higher (IX).

Do not stand in the cutting plane. This will reduce the risk of injury in case of kickback (X).

During work, always hold the chainsaw with both hands.

Make sure that the chain is always sharp and appropriately tensioned.

TIPS FOR WORKING WITH THE CHAINSAW

Take a comfortable position and ensure full freedom of movement when cutting.

When cutting branches and boughs, do not cut them at the trunk, but at a distance of about 15 cm from the trunk. Make two cuts to a depth of 1/3 of the branch diameter, approximately 8 cm apart. One cut from below, one from above. Then cut the branch just at the trunk to a depth equal to 1/3 of the branch diameter. Finish the process by cutting the branch at the trunk from above. Do not cut the branches by cutting from the bottom (XI).

When cutting a tree, prepare the felling site in advance as described above. Additionally, prepare a safe substrate for tree felling.

When a tree falls, stand at a safe distance to the plane of the tree fall, on the side. When choosing the path of wood fall, take into account factors such as terrain topography, tree centre of gravity, tree crown pattern, and wind direction. To properly prepare the tree for felling, make a cut in the trunk to a depth of 1/3 of the trunk diameter on the side to which the tree is to fall, and then cut another at an angle of 45 degrees to the first so as to cut a "wedge" in the trunk. On the other side of the trunk, start cutting perpendicular to the trunk axis, slightly higher (approx. 4 cm) than the cut "wedge" base. Do not cut the trunk. Leave a section of approximately 1/10 of the trunk diameter. Then insert the wedge for splitting the tree into the cut on the opposite side to the planned side of the tree fall (XII).

If the tree already falls during cutting, pull the chainsaw out of the trunk and move away along the prepared escape route to a safe distance.

If the chainsaw gets stuck while cutting the trunk, never leave it in this position with the motor running. Turn off the chainsaw motor, unplug the chainsaw from the power supply, and use wedges to extract the chainsaw from the trunk.

When cutting a tree that has already been felled into pieces, follow the rules indicated below. Place the wood on the saw-horse or a stand so the cut piece can freely fall off to the ground without causing the chainsaw to jam. If the chainsaw is jammed, proceed as described above. Do not touch the ground with the chainsaw or allow it to be contaminated with soil. It is forbidden to use a chainsaw to form hedges or shear bushes.

When working on a slope, stay above the cut wood.

Exercise particular caution when cutting a tensioned tree and entrust this activity to a qualified lumberjack, if possible. When cutting tensioned wood and supported on both ends, cut it from above to a depth of 1/3 of the diameter, and then finish the cut from the bottom.

If the wood is supported at only one end, cut the wood from the bottom to a depth of 1/3 of the diameter and then complete the cut by cutting from above (XIII).

This will reduce the risk of the chainsaw jamming during cutting.

Extension cords

Extension cords must be adapted for use outside confined spaces.

The extension cord cores must have a cross-section at least equal to the cross-section of the core of the device's power cord. The rated power that the extension cord can transfer must be at least equal to the power consumed by the device.

PRODUCT MAINTENANCE AND STORAGE

Caution! Disconnect the chainsaw from the power supply before starting any activities described below. Disconnect the mains-powered chainsaws from the socket. In the case of the battery-powered chainsaws, disconnect their battery.

After each use, check the chainsaw condition paying particular attention to ventilation openings flow capacity.

Check the location of all chainsaw elements. Tighten all loose screw connections, if any. Check chain tension and condition. If any chain damages are found, replace it with a new one. It is forbidden to operate the chainsaw with a damaged chain!

Too loose a chain may fall off the guide bar, which can lead to injury to the chainsaw operator. Moreover, the chain must also be properly sharpened. As this requires appropriate experience and tools, it is recommended that a specialist service carries out the sharpening.

Top up the oil in the tank. Clean the chainsaw housing with soft and dry cloth. Clean the chainsaw housing of the wood residues, oil, grease, and other contamination. Store the chainsaw disconnected from the mains in a dry, closed room.

Caution! During the chainsaw storage, a small amount of oil can escape from the chain

lubrication system. This is a normal symptom and does not affect the oil level in the tank and is not a sign of damage.

Store the chainsaw in shaded, dry places with appropriate ventilation preventing steam condensation. The place should be inaccessible to unauthorised persons, especially children. During storage, the guide bar and chain should always be protected with a guard.

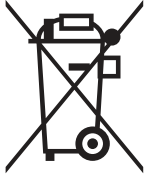

This symbol indicates that waste electrical and electronic equipment (including batteries and storage cells) cannot be disposed of with other types of waste. Waste equipment should be collected and handed over separately to a collection point for recycling and recovery, in order to reduce the amount of waste and the use of natural resources. Uncontrolled release of hazardous components contained in electrical and electronic equipment may pose a risk to human health and have adverse effects for the environment.

The household plays an important role in contributing to reuse and recovery, including recycling of waste equipment. For more information about the appropriate recycling methods, contact your local authority or retailer.

US

Imported by Aosom LLC
27150 SW Kinsman Rd Wilsonville, OR 97070 USA
MADE IN CHINA

CA

Imported by Aosom Canada Inc.
7270 Woodbine Avenue, Unit 307, Markham, Ontario Canada
L3R 4B9
MADE IN CHINA

Importé par Aosom Canada Inc.
7270 Woodbine Avenue, unité 307, Markham, Ontario Canada
L3R 4B9
Fabriqué en Chine

UK

IMPORTER ADDRESS:
MH STAR UK LTD
Unit 27, Perivale Park,
Horsenden lane South
Perivale, UB6 7RH
MADE IN CHINA

FR

ADRESSE D'IMPORTATION:
MH FRANCE
2 Rue Maurice Hartmann
92130 Issy Les Moulineaux
France
FABRIQUÉ EN CHINE

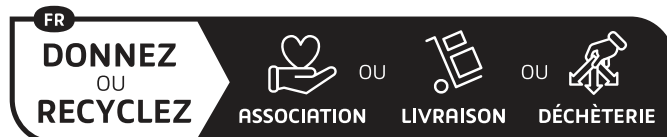

Adresses sur quefairedemesdechets.fr

ES

IMPORTADOR:
SPANISH AOSOM, S.L.
C/ROC GROS, Nº15.08550, ELS HOSTALET DE BALENYÀ, SPAIN.
B66295775
WWW.AOSOM.ES
ATENCIONCLIENTE@AOSOM.ES
TEL: 931294512
HECHO EN CHINA

PT

SPANISH AOSOM, S.L
C.ROC GROS N.15, 08550. ELS HOSTALET DE BALENYÀ
TEL: 931294512 (SEG-SEX DAS 7:30H ÀS 16:30H)
INFO@AOSOM.PT
WWW.AOSOM.PT

DE

ADRESSE DES IMPORTEURS:
MH Handel GmbH
Wendenstraße 309
D-20537 Hamburg
Germany
IN CHINA HERGESTELLT

IT

IMPORTATO DA:
AOSOM Italy srl
Centro Direzionale Milanofiori
Strada 1 Palazzo F1
20057 Assago (MI)
P.I.: 08567220960
FATTO IN CINA