

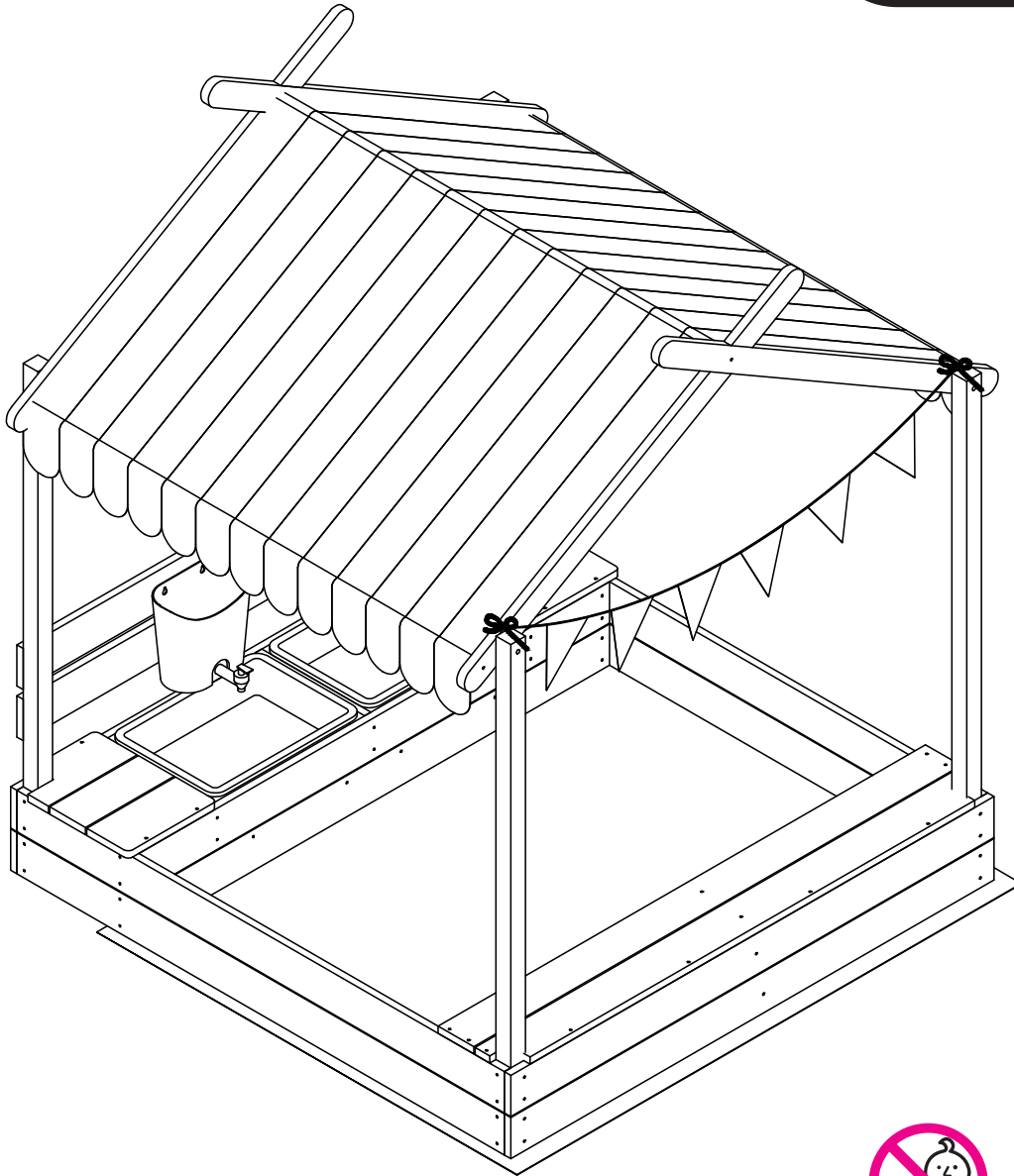

IN230800474V01_GL

343-063V00



EN_IMPORTANT, RETAIN FOR FUTURE REFERENCE: READ CAREFULLY.

FR_IMPORTANT: A LIRE ATTENTIVEMENT ET À CONSERVER POUR CONSULTATION ULTÉRIEURE.

ES_IMPORTANTE, LEA Y GUARDE PARA FUTURAS REFERENCIAS.

PT_IMPORTANTE, RETER PARA REFERÊNCIA FUTURA: LEIA ATENTAMENTE.

DE_WICHTIG! SORGFÄLTIG LESEN UND FÜR SPÄTER NACHSCHLAGEN AUFBEWAHREN.

IT_IMPORTANTE! CONSERVARE IL PRESENTE MANUALE PER FUTURO RIFERIMENTO E LEGGERLO ATTENTAMENTE.

EN

Dear customer,

Thank you for purchasing this product. So that your appliance serves you well, please read all the instructions in this user's manual. If you have any questions, please contact our customer care center, Our contact details are below:

FR

Cher client,

Nous vous remercions d'avoir acheté ce produit. Afin que vous puissiez profiter pleinement de votre appareil, veuillez lire toutes les instructions de ce manuel d'utilisation. Si vous avez la moindre question, veuillez contacter notre centre d'assistance à la clientèle, Nos coordonnées sont les suivantes:

DE

Sehr geehrter Kunde,

Vielen Dank, dass Sie dieses Produkt erworben haben. Damit Ihr Gerät Ihnen gute Dienste leistet, lesen Sie bitte alle Hinweise in diesem Benutzerhandbuch. Wenn Sie Fragen haben, wenden Sie sich bitte an unser Kundendienstzentrum, Unsere Kontaktdaten stehen unten:

ES

Queridos clientes,

Gracias por comprar este producto. Para que su electrodoméstico le sirva mejor, lea todas las instrucciones de este manual del usuario. Si tiene alguna pregunta, comuníquese con nuestro Centro de Atención al Cliente, Nuestros datos de contacto son los siguientes:

PT



Caros clientes,

Obrigado por adquirir este produto. Para que o seu aparelho o sirva melhor, leia todas as instruções deste manual do utilizador. Se tiver alguma dúvida, por favor contacte o nosso Centro de Atendimento ao Cliente, Os nossos dados de contacto são os seguintes:

IT

Caro Cliente,

Grazie per aver acquistato questo prodotto. Per servirti meglio con questo apparecchio ti prego di leggere tutte le istruzioni in presente manuale utente. In caso di dubbio, si prega di contattare il nostro centro assistenza clienti, I nostri dettagli di contatto sono di seguito:

Country	 Phone	 Email
US	001-877-644-9366	customerservice@aosom.com
CA	416-792-6088	customerservice@aosom.ca
UK	0044-800-240-4004	enquiries@mhstar.co.uk
DE	0049-0(40)-88307530	service@aosom.de
FR	0033-1-84166106	aosom@mhfrance.fr
ES	0034-931294512	atencioncliente@aosom.es
PT	0034-931294512	info@aosom.pt
IT	0039-0249471447	clienti@aosom.it

Advice for assembly

- Respect exactly the assembly instructions. This product must be assembled by an adult.
- Keep the instruction sheet especially for the identification of the component by the after sales service.
- Before commencing, check that none of the parts are missing. You can retain excess parts as spares for future use when necessary.

Advice for safety

- This product must not be used by children under 6 months. It is only for children from 3 to 7 with a 50 kg maximum weight.
- This product is only for private use at home and must never be used in parks and public gardens.
- In certain regions (ie seaside areas), certain coatings could be prone to damage. In this case, it is advised to use a rust prevention treatment.
- It is advised to remove the apparatus during the winter period, to avoid any deterioration due to bad weather conditions.

Conseil de montage

- Respectez scrupuleusement les instructions de montage. Ce produit doit être assemblé par un adulte.
- Conservez la fiche d'instructions spécialement pour l'identification du composant par le service après-vente.
- Avant de commencer, vérifiez qu'aucune des pièces ne manque. Vous pouvez conserver les pièces en surplus en tant que pièces de rechange pour une utilisation ultérieure, si nécessaire.

Conseils de sécurité

- Ce produit ne doit pas être utilisé par des enfants de moins de 6 mois. Ce n'est que pour les enfants de 3 à 7 ans avec un poids maximum de 50 kg.
- Ce produit est uniquement destiné à un usage privé à la maison et ne doit jamais être utilisé dans les parcs et les jardins publics.
- dans certaines régions (zones côtières), certains revêtements pourraient être endommagés. Dans ce cas, il est conseillé d'utiliser un traitement de prévention de la rouille.
- Il est conseillé de retirer l'appareil en hiver, lorsqu'il n'est pas utilisé, pour éviter toute détérioration due aux mauvaises conditions météorologiques.

Consejos para el montaje.

- Respete exactamente las instrucciones de montaje. Este producto debe ser montado por un adulto.
- Conserve la guía de instrucciones especialmente para la identificación de componentes por el servicio postventa.
- Antes de comenzar, compruebe que no falta ninguna de las piezas. Puede guardar el exceso de piezas como repuesto para uso futuro cuando sea necesario.

Consejos de seguridad.

- Este producto no debe ser usado por niños menores de 6 meses. Solo para niños de 3 a 7 años con un peso máximo de 50 kg.
- Este producto es solo para uso privado en el hogar y nunca debe usarse en parques y jardines públicos.
- en ciertas regiones (es decir, zonas costeras), ciertos recubrimientos podrían ser propensos a daños. En este caso, se aconseja utilizar un tratamiento de prevención de oxidación.
- Se recomienda retirar el aparato durante el período de invierno, cuando no esté en uso, para evitar cualquier deterioro debido a condiciones climáticas adversas.

Instruções de Montagem

- Respeitar exatamente as instruções de montagem. Este produto deve ser montado por um adulto.
- Guarde este manual de instruções, especialmente para a identificação do componente pelo serviço pós-venda.
- Antes de começar, verificar se nenhuma das peças está em falta. Pode conservar as peças em excesso como peças de reserva para utilização futura, quando necessário.

Conselhos de Segurança

- Este produto não deve ser utilizado por crianças com menos de 6 meses. É apenas para crianças de 3 a 7 anos com um peso máximo de 50 kg.
- Este produto é apenas para uso privado em casa e nunca deve ser utilizado em parques e jardins públicos.
- Em certas regiões (ou seja, zonas costeiras), certos materiais de revestimento podem ser susceptíveis de serem danificados. Neste caso, aconselha-se a utilização de um tratamento antiferrugem.
- Aconselha-se a remoção do aparelho durante o período de Inverno, para evitar qualquer deterioração devido a más condições climáticas.

Hinweise zur Montage

- Beachten Sie genau die Montageanleitung. Dieses Produkt muss von einem Erwachsenen zusammengebaut werden.
- Bewahren Sie die Bedienungsanleitung insbesondere für die Identifizierung des Bauteils durch den Kundendienst auf.
- Überprüfen Sie vor Beginn der Arbeiten, ob keines der Teile fehlt. Sie können überschüssige Teile als Ersatzteile für den späteren Gebrauch aufbewahren.

Sicherheitshinweise

- Dieses Produkt darf nicht von Kindern unter 6 Monaten verwendet werden. Es ist nur für Kinder von 3 bis 7 Jahren mit einem Maximalgewicht von 50 kg geeignet.
- Dieses Produkt ist nur für den privaten Gebrauch zu Hause bestimmt und darf niemals in Parks und öffentlichen Gärten.
- In bestimmten Regionen (z.B. Küstengebieten) können jedoch bestimmte Beschichtungen anfällig für Schäden sein. In diesem Fall wird empfohlen, eine Rostschutzbehandlung zu verwenden.
- Es wird empfohlen, das Gerät während der Winterzeit zu entfernen, wenn es nicht in Gebrauch ist, um eine Verschlechterung durch schlechte Wetterbedingungen zu vermeiden.







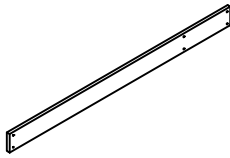
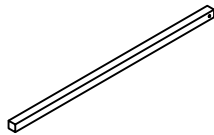
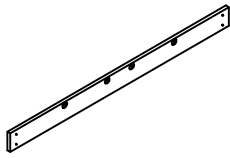
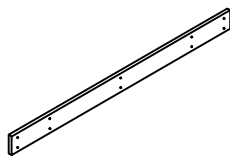
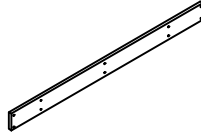
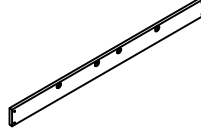

Consigli per l'assemblaggio

- Attenersi alle istruzioni di montaggio. Questo prodotto deve essere assemblato da un adulto.
- Tenere il foglio di istruzioni soprattutto per l'identificazione del componente dal servizio post-vendita.
- Prima di iniziare, verificare che nessuna parte manchi. È possibile mantenere le parti in eccesso come ricambi per l'utilizzo futuro quando necessario.

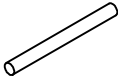
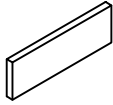
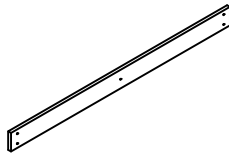
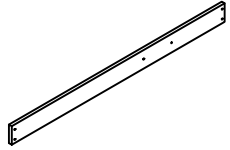
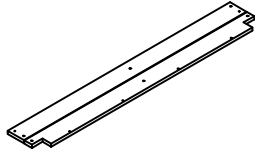
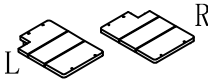
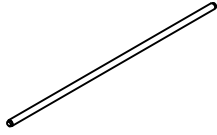

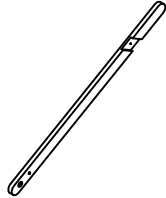

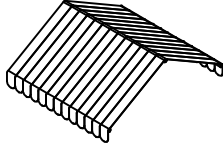

Consigli per la sicurezza

- Questo prodotto non deve essere utilizzato dai bambini di età inferiore ai 6 mesi. L'apparecchiatura è esclusivamente per i bambini dai 3 a 7 anni che hanno un peso massimo di 50 kg. L'altalena dev'essere utilizzata sotto la supervisione degli adulti.
- Questo prodotto è solo per uso privato a casa e non deve mai essere utilizzato in parchi e giardini pubblici.
- Le parti in metallo non necessitano di alcuna cura particolare. Tuttavia, in alcune regioni (ad esempio aree costiere), alcuni rivestimenti potrebbero essere soggetti a danni. In questo caso, si consiglia di utilizzare un trattamento antiruggine.
- Si consiglia di rimuovere l'apparecchio durante il periodo invernale, quando non in uso, per evitare qualsiasi deterioramento dovuto a condizioni meteorologiche avverse.

PARTS

 1 x 4	 2 x 4	 3 x 1	 4 x 1
 5 x 1	 6 x 1	 7 x 2	 8 x 4
 9 x 3	 10 x 2	 11 x 2	 12 x 1
 13 x 2	 14 x 3	 15 x 2	 16 x 2
 17 x 1	 18 x 1	 19 x 1	 20 x 1

HARDWARE

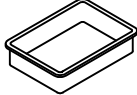
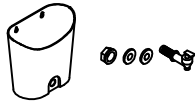
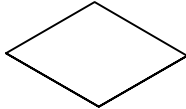
 A x62 M4*35	 B x34 M3*35	 C x4 M3*25	 D x2 M3*16	 E x4 M6*45
 F x 4 M6*15	 G x 2	 H x 1	 I x 1	

A x 16

01

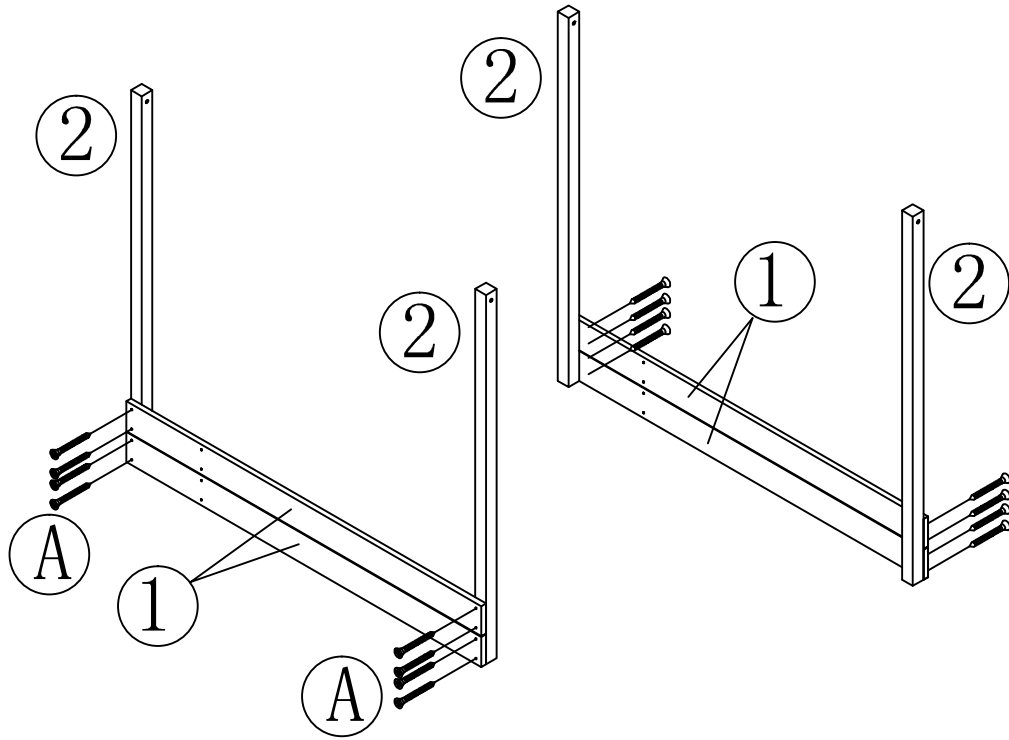

A x 8

02

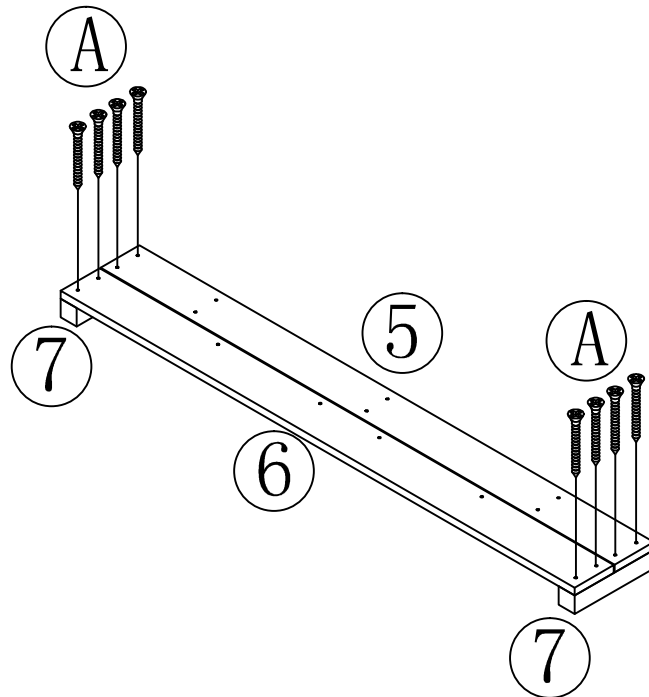

A x 8

03

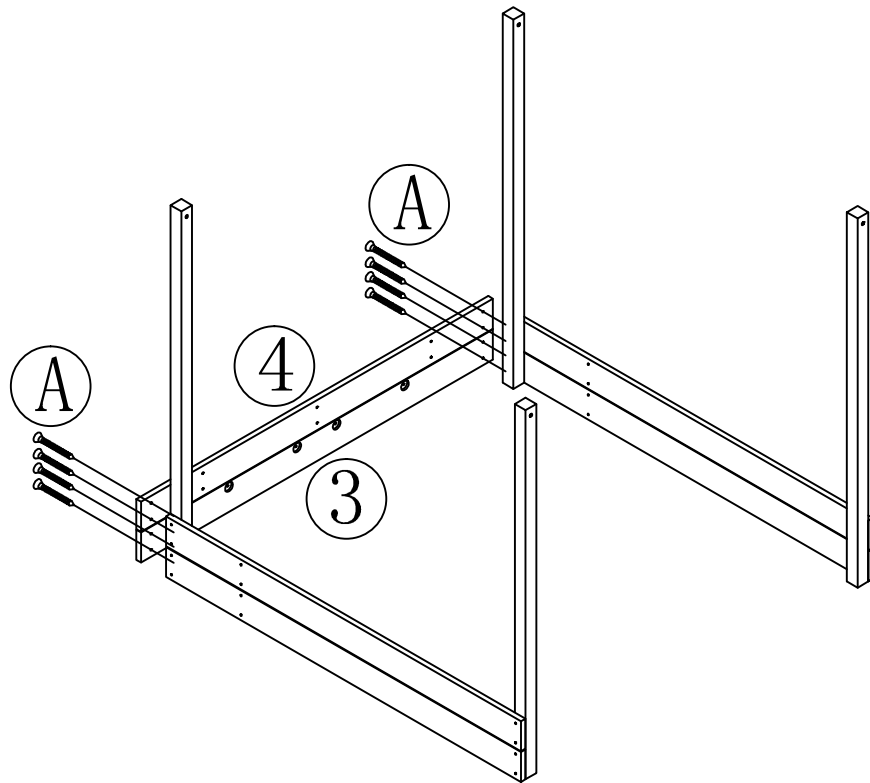

A x 4

04

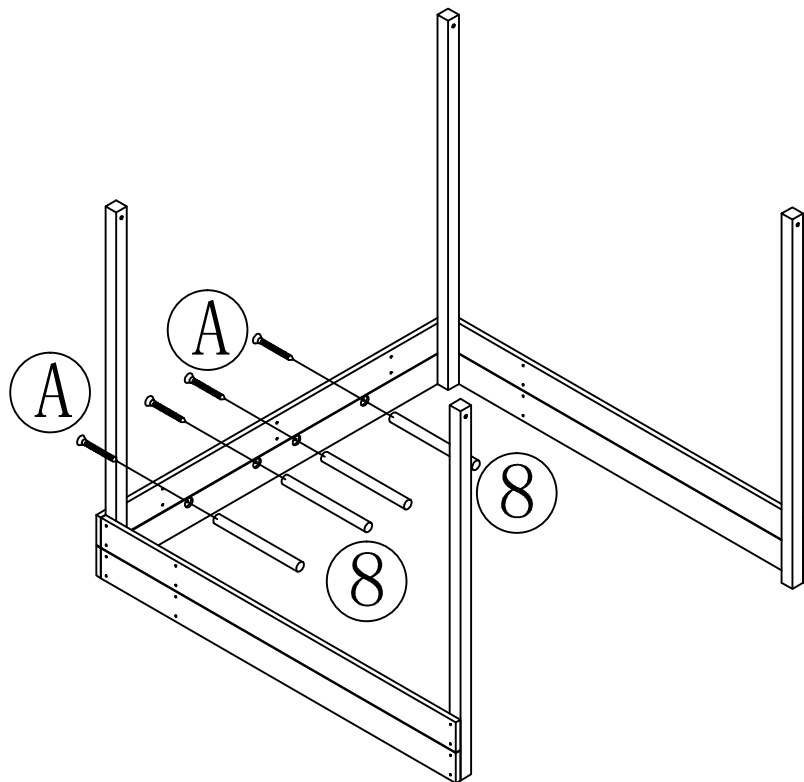

A x 4

05

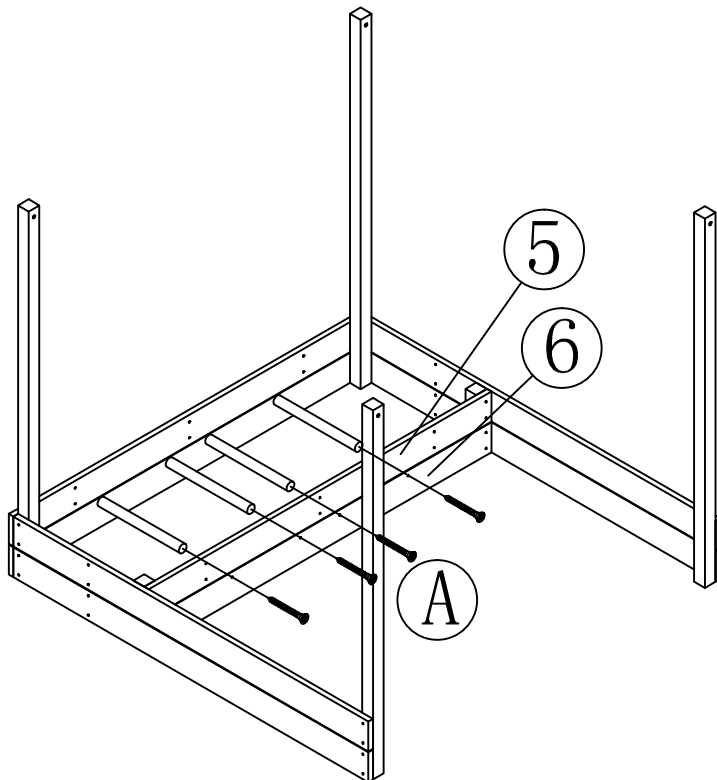

B x 12

06

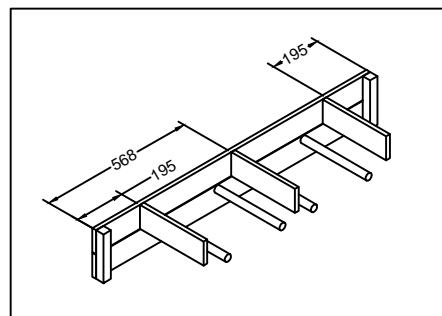
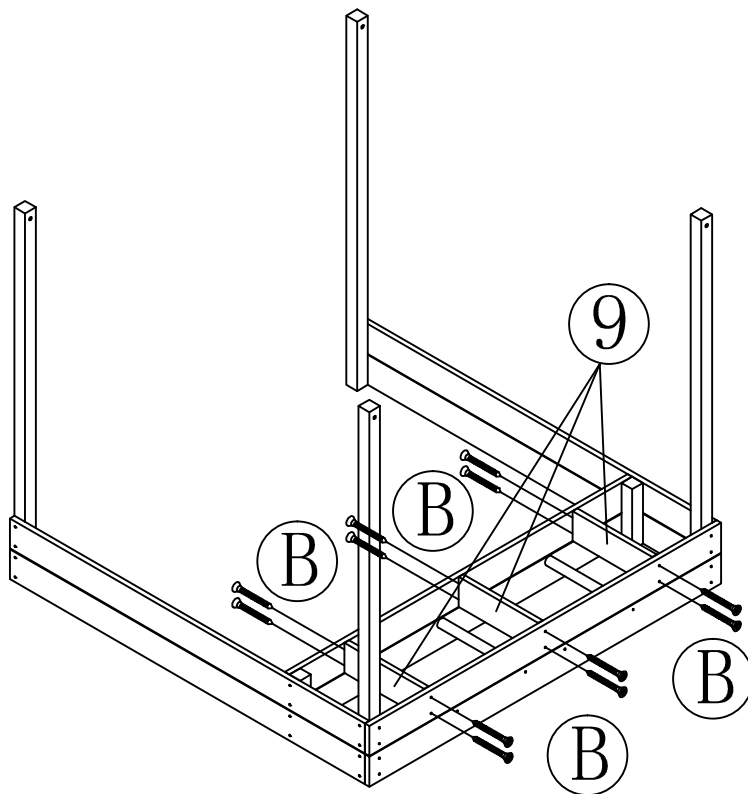

A x 8
B x 2

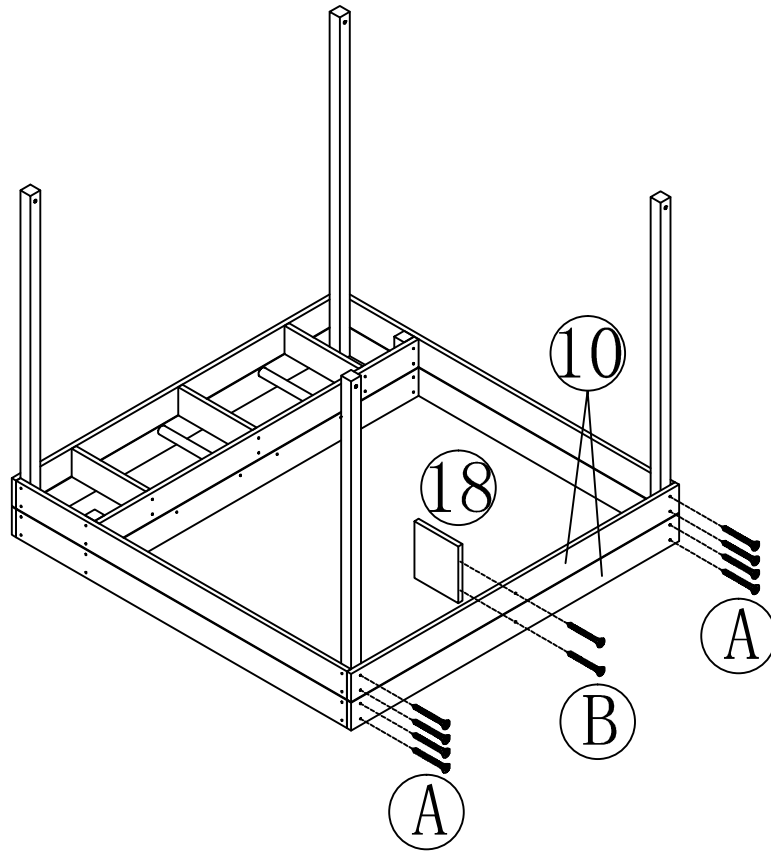

B x 20

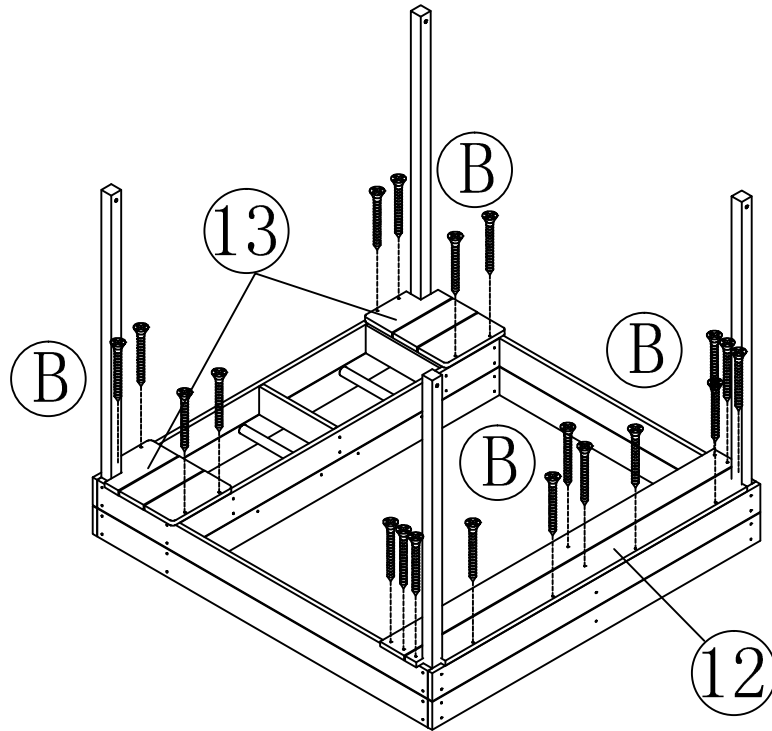

A x 8

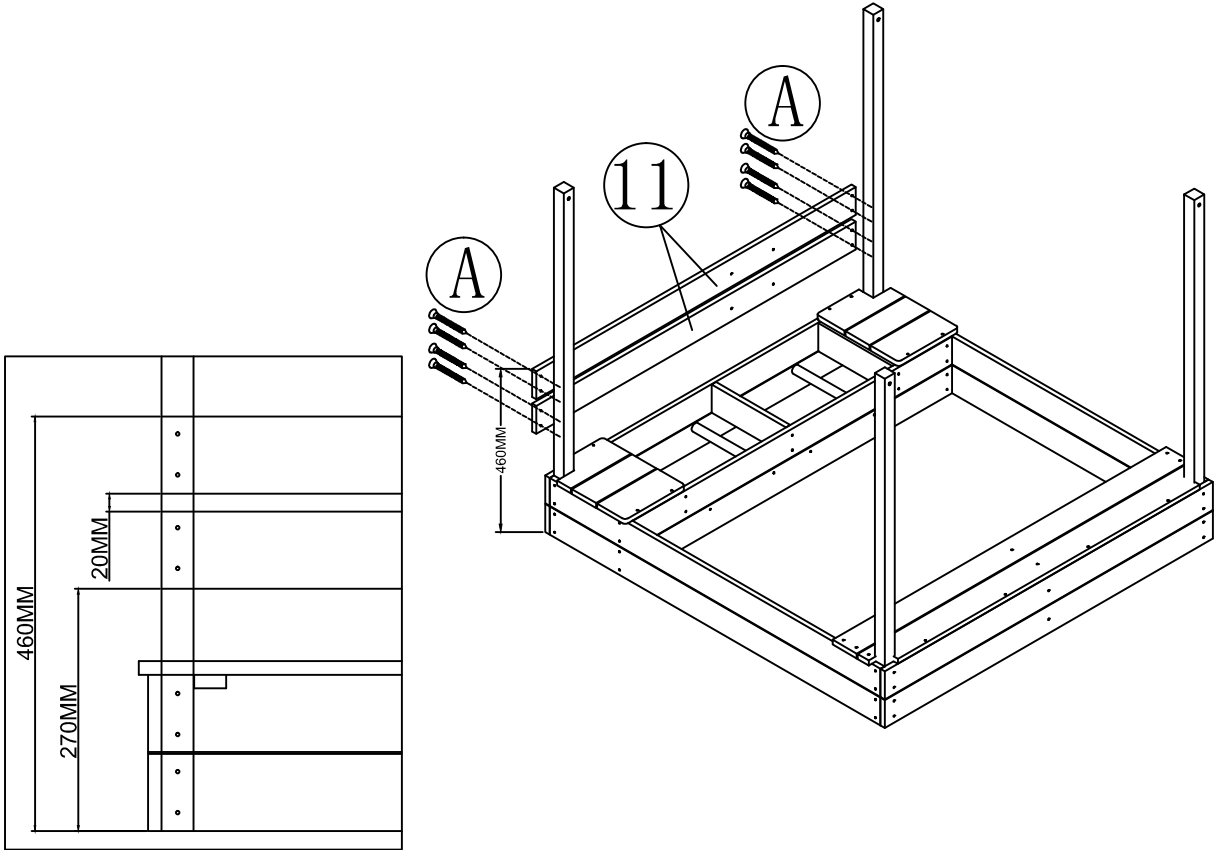

A x 3

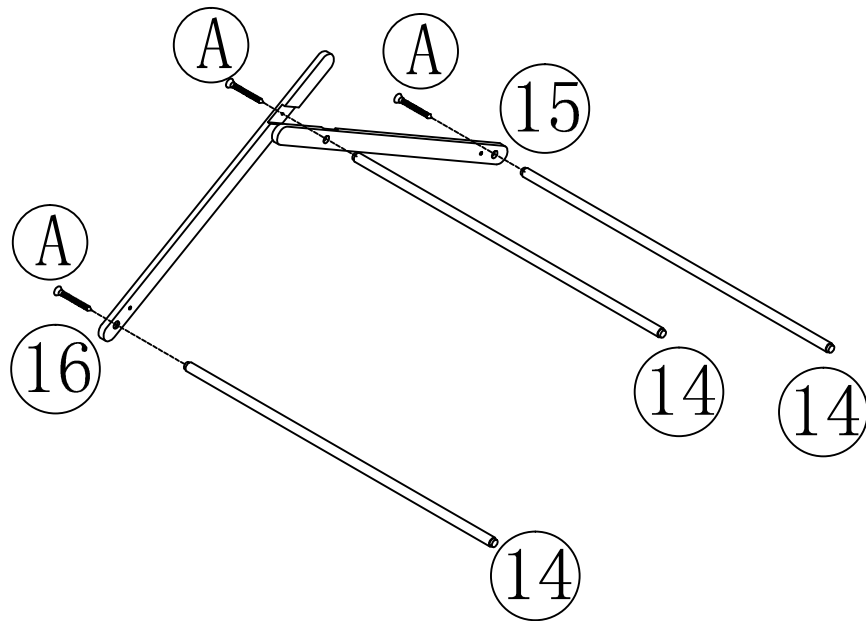

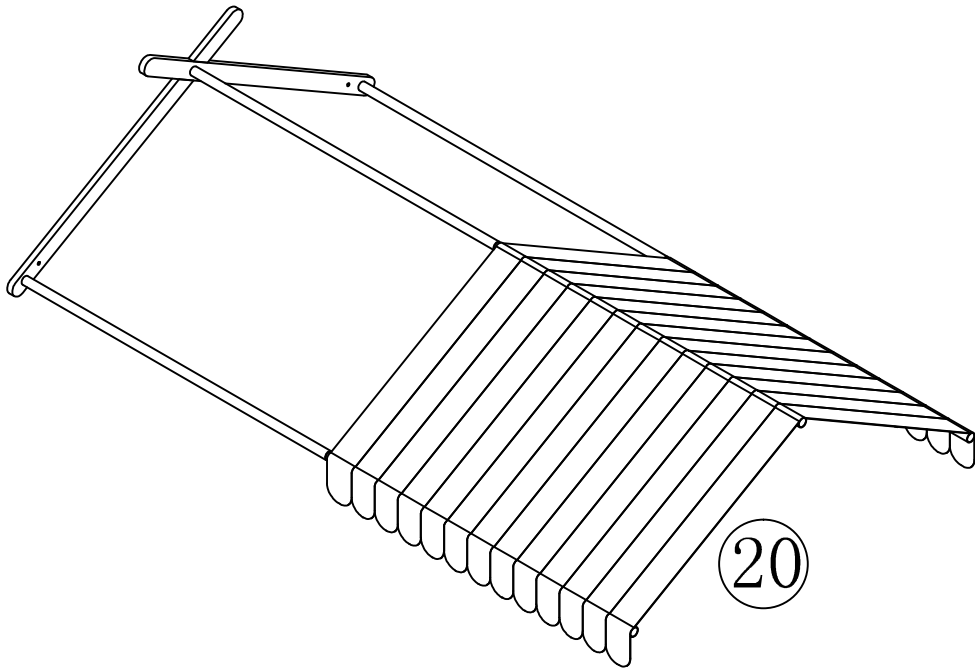

A x 3

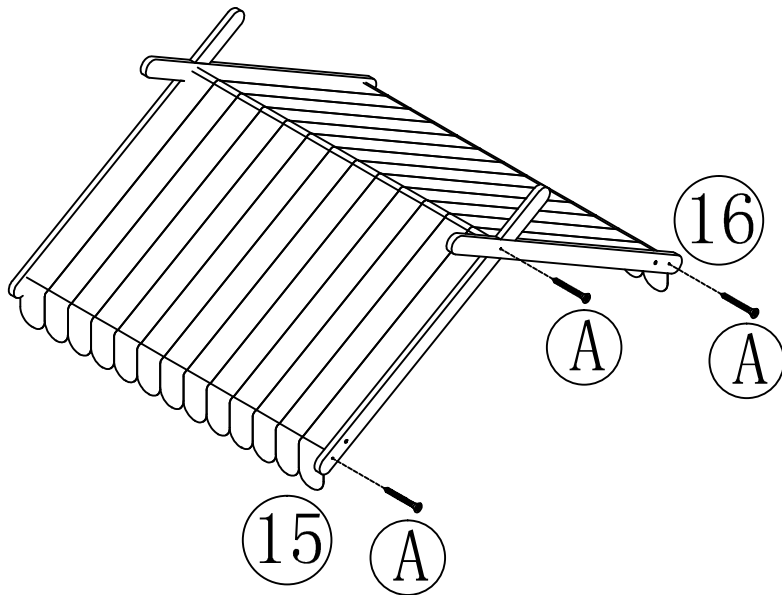

H x 1

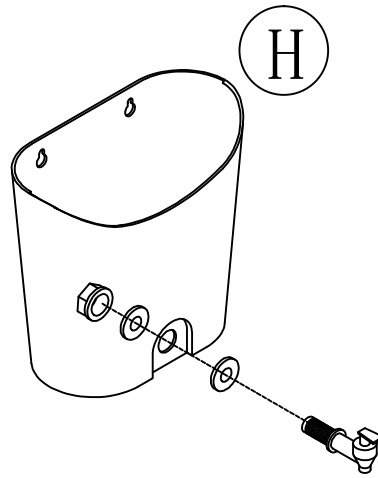

D x 2

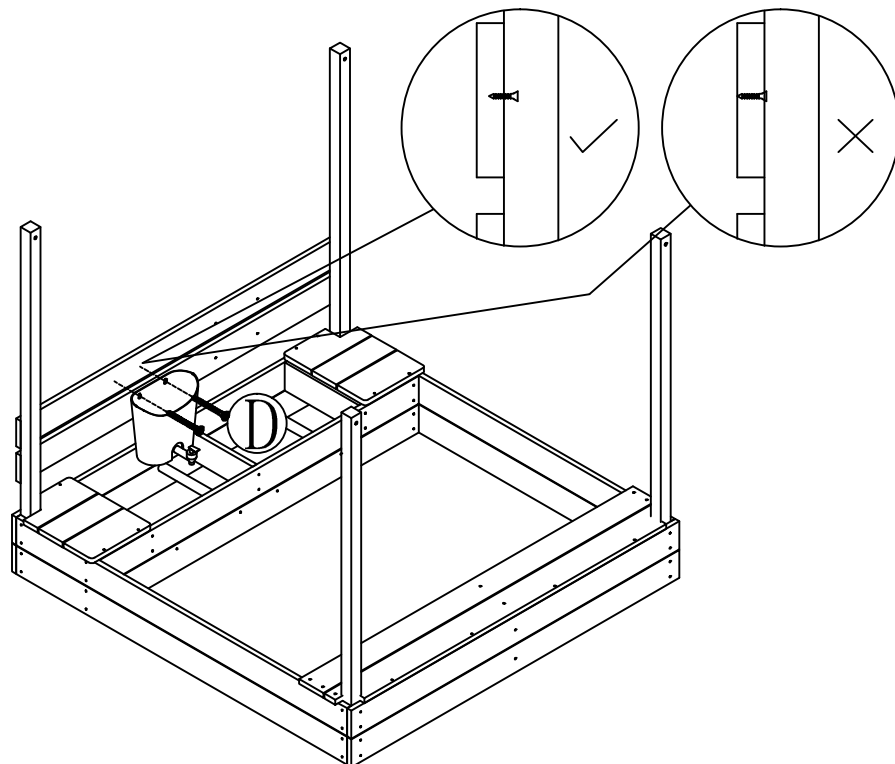

C x 4
G x 2

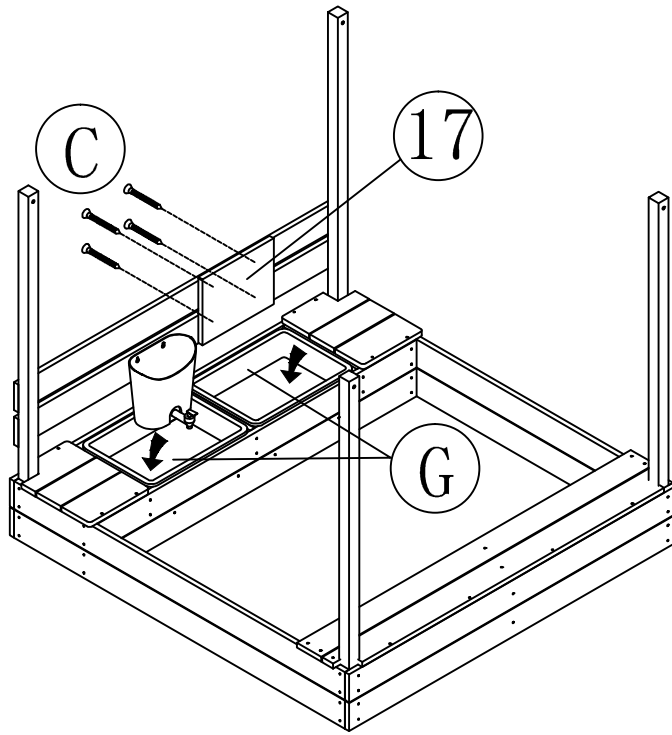

E x 4
F x 4

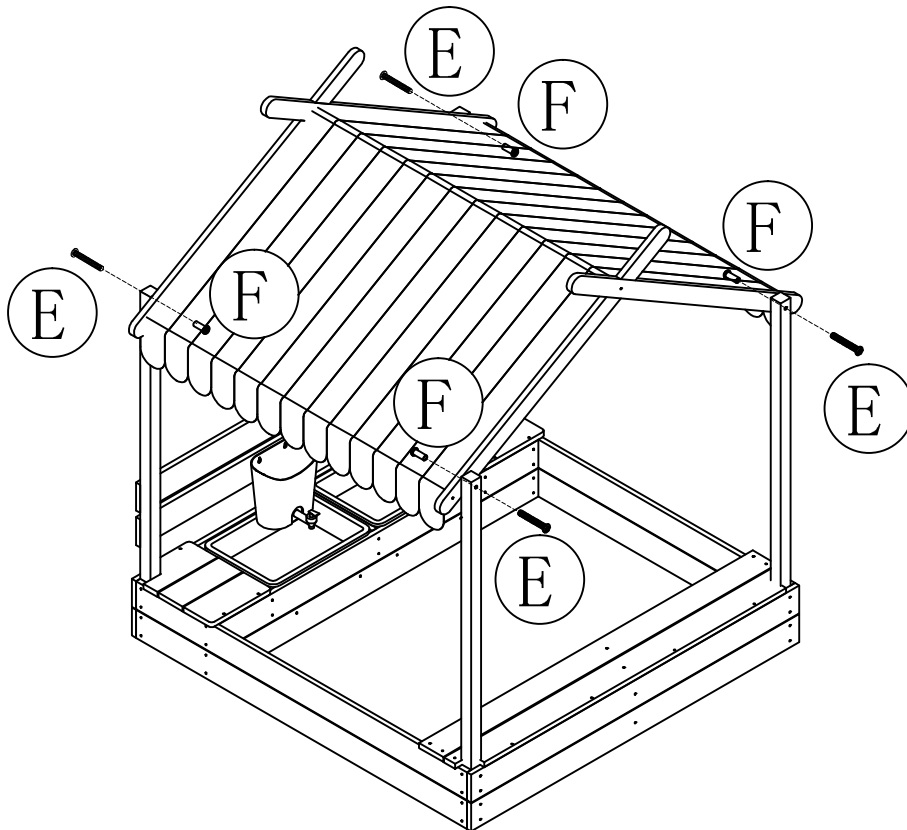

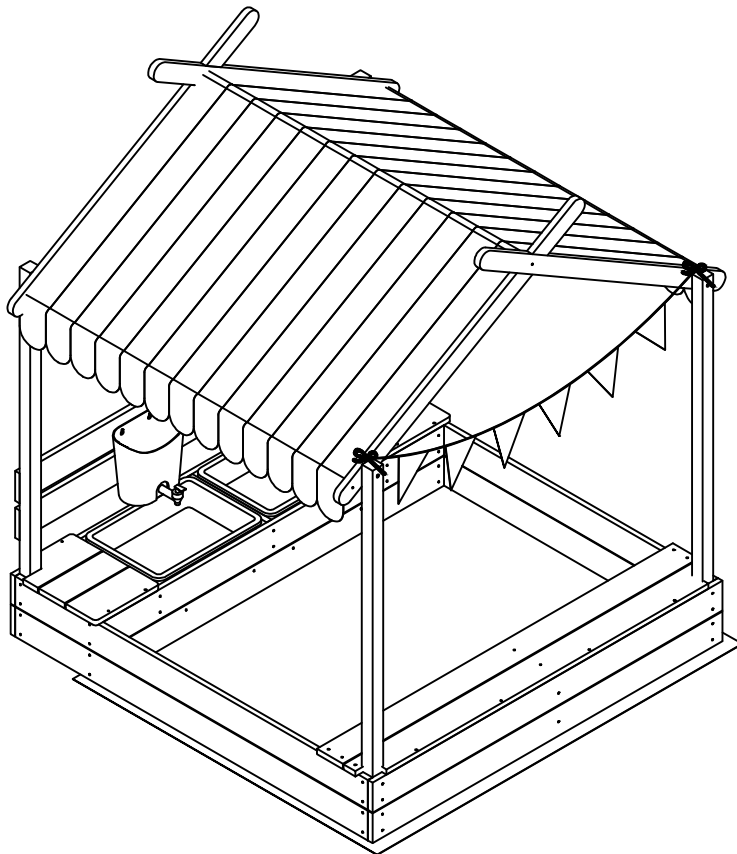
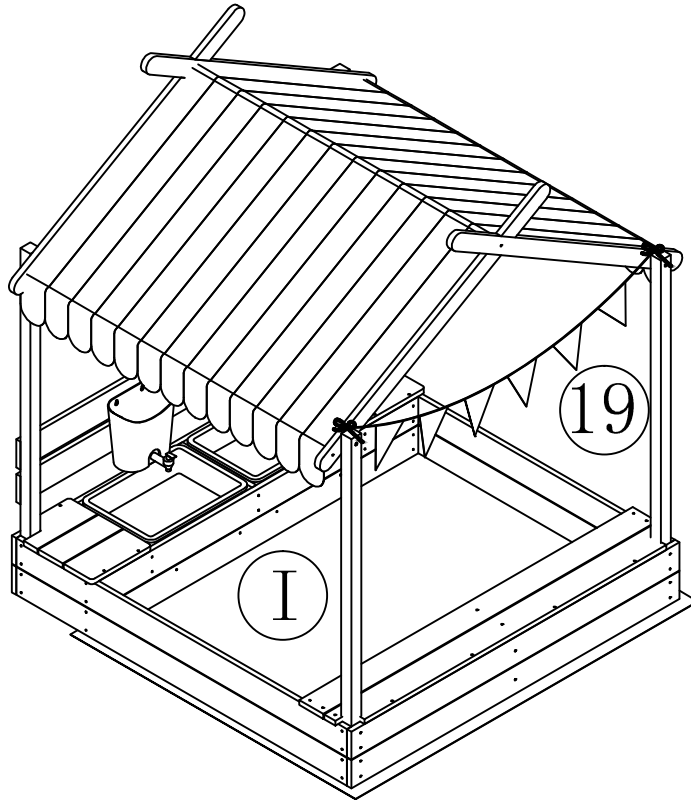

US

Imported by Aosom LLC
 27150 SW Kinsman Rd Wilsonville, OR 97070 USA
 MADE IN CHINA

CA

Imported by Aosom Canada Inc.
 7270 Woodbine Avenue, Unit 307, Markham, Ontario Canada
 L3R 4B9
 MADE IN CHINA

Importé par Aosom Canada Inc.
 7270 Woodbine Avenue, unité 307, Markham, Ontario Canada
 L3R 4B9
 Fabriqué en Chine

UK

IMPORTER ADDRESS:
 MH STAR UK LTD
 Unit 27, Perivale Park,
 Horsenden lane South
 Perivale, UB6 7RH
 MADE IN CHINA

FR

ADRESSE D'IMPORTATION:
 MH FRANCE
 2 Rue Maurice Hartmann
 92130 Issy Les Moulineaux
 France
 FABRIQUÉ EN CHINE



Adresses sur quefairedemesdechets.fr

ES

IMPORTADOR:
 SPANISH AOSOM, S.L.
 C/ROC GROS, Nº15.08550, ELS HOSTALET DE BALENYÀ, SPAIN.
 B66295775
 WWW.AOSOM.ES
 ATENCIONCLIENTE@AOSOM.ES
 TEL: 931294512
 HECHO EN CHINA

PT

SPANISH AOSOM, S.L
 C.ROC GROS N.15, 08550. ELS HOSTALET DE BALENYÀ
 TEL: 931294512 (SEG-SEX DAS 7:30H ÀS 16:30H)
 INFO@AOSOM.PT
 WWW.AOSOM.PT

DE

ADRESSE DES IMPORTEURE:
 MH Handel GmbH
 Wendenstraße 309
 D-20537 Hamburg
 Germany
 IN CHINA HERGESTELLT

IT

IMPORTATO DA:
 AOSOM Italy srl
 Centro Direzionale Milanofiori
 Strada 1 Palazzo F1
 20057 Assago (MI)
 P.I.: 08567220960
 FATTO IN CINA