

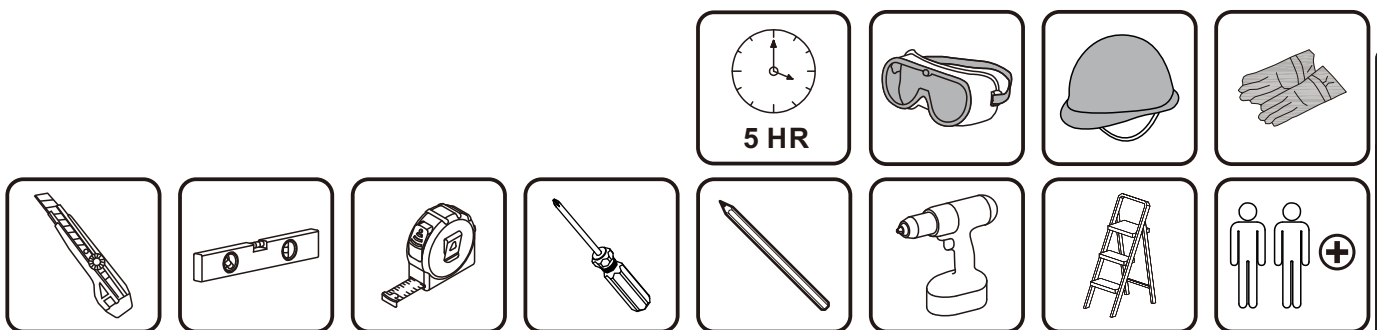

IN230900223V02\_UK\_FR\_US\_CA

845-678

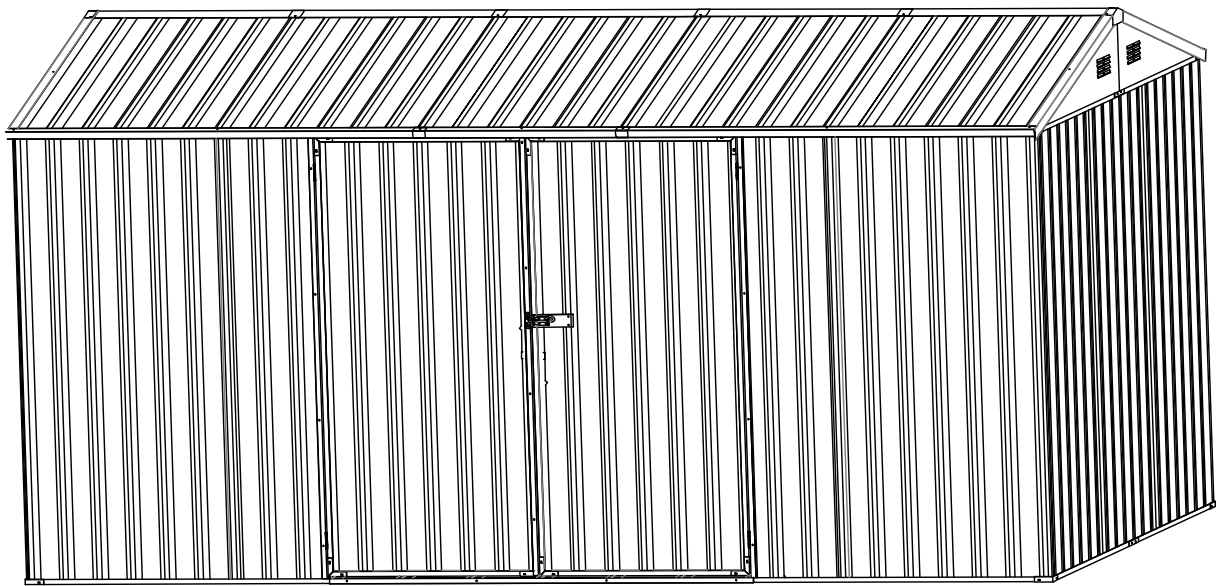

Tools Recommended

**EN\_IMPORTANT, RETAIN FOR FUTURE REFERENCE: READ CAREFULLY.**

**FR\_IMPORTANT: A LIRE ATTENTIVEMENT ET À CONSERVER POUR CONSULTATION ULTÉRIEURE.**

**ES\_IMPORTANTE, LEA Y GUARDE PARA FUTURAS REFERENCIAS.**

**PT\_IMPORTANTE, RETER PARA REFERÊNCIA FUTURA: LEIA ATENTAMENTE.**

**DE\_WICHTIG! SORGFÄLTIG LESEN UND FÜR SPÄTER NACHSCHLAGEN AUFBEWAHREN.**







**IT\_IMPORTANTE! CONSERVARE IL PRESENTE MANUALE PER FUTURO RIFERIMENTO E LEGGERLO ATTENTAMENTE.**

BOX-1	
EP2	8
EP3	2
EFU1	1
EFU3	1
EFU6	1
EFU8	1
EFB1	1
EFB3	1
EFB6	1
EFB8	1
FM2	1
EBF2	1
EDF2	1
EDF3	1
EDF4	1
EDF5	1
EFU4	2
EFU5	2
EFB4	4
ET1	1
ET2	1
ET3	1
EL2	4
EV3	2
EV4	2
EV1	2
EV2	1
EVJ1	2
BS5	4
BS4	4
BS6	2
BSM	4
Hardware Kit	

BOX-2	
EP1	21
EDP1	2
EDP2	2
EGL1	2
EGR1	2

BOX-3	
EPT1	22
EFU2	1
EFU7	1
ER1	11
EFB2	1
EFB7	1
FM1	4
FM4	4
EDT1	4
ED1	4
ED2	2
EL1	4
EL3	2
EF1	32

## Required tools:

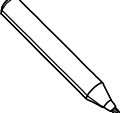
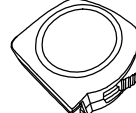
Tools				
	Gloves	Safety Glasses	Table	Ladder
				
	Power drill	Screw driver	Pencil	Tape Measure







## Tips:

1. Clear a working area to allow access on 4 sides. A raised work surface will make assembly easier, it is easier to install the wall panel on the table.
2. All parts are identified so when working through the instructions page by page the diagrams show where each part is positioned.
3. Most pre-punched holes need to be fixed with self-tapping screws, and a few holes need to use self-drilling screws.
4. Before starting, to avoid any accidental injury, we recommend the use of gloves to protect your hands, safety glasses to protect your eyes and shoes or boots to protect your feet.
5. Please keep children away from your construction site.
6. Most assembly can be completed by one person, assistance may be needed when you reach the erection stage.
7. Please note: Some local government authorities have rules & regulations on shed installation and you may need approval to erect this shed.

## Steps:

1. Unpack all components from the carton and lay outside your work area and check parts against the part list.
2. Work through assembly instructions page by page.
3. When assembly completed, place the shed in position and fix anchor to the ground.
4. Clean up all metal pieces and screws.

Outils nécessaires :

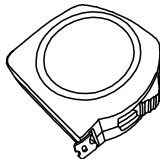
Outils				
	Gants	Verres de sécurité	Tableau	Échelle
				
	Perceuse électrique	Entraînement par vis	Crayon	Ruban à mesurer

Conseils :

- dégagez un espace de travail pour permettre l'accès sur les 4 côtés. Une surface de travail surélevée facilitera l'assemblage. Il est plus facile d'installer le panneau mural sur la table.
- toutes les pièces sont identifiées, de sorte que lorsque vous lisez les instructions page par page, les diagrammes indiquent la position de chaque pièce.
- la plupart des trous pré-perforés doivent être fixés à l'aide de vis autotaraudeuses, et quelques trous doivent être fixés à l'aide de vis autoperceuses.
- Avant de commencer, pour éviter toute blessure accidentelle, nous vous recommandons de porter des gants pour protéger vos mains, des lunettes de sécurité pour protéger vos yeux et des chaussures ou des bottes pour protéger vos pieds.
- Veillez tenir les enfants à l'écart de votre chantier de construction.
- la plupart des opérations d'assemblage peuvent être réalisées par une seule personne, mais une assistance peut être nécessaire lorsque vous atteignez le stade de l'érection.
- Veillez noter que certaines autorités locales ont des règles et des réglementations concernant l'installation des cabanons et qu'il se peut que vous ayez besoin d'une autorisation pour ériger ce cabanon.

Étapes :

- déballez tous les composants du carton et placez-les à l'extérieur de votre zone de travail, puis vérifiez les pièces par rapport à la liste des pièces.
- lisez les instructions d'assemblage page par page.
- une fois l'assemblage terminé, placez l'abri en position et fixez l'ancrage au sol.
- nettoyez toutes les pièces métalliques et les vis.

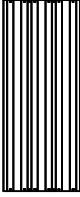
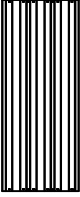
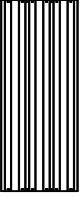
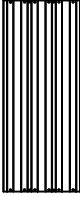
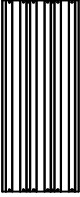
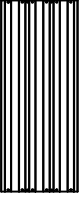
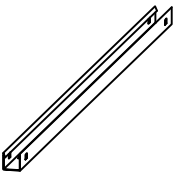
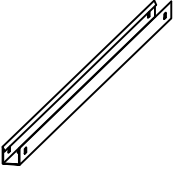
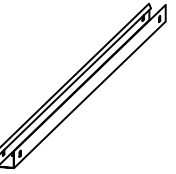
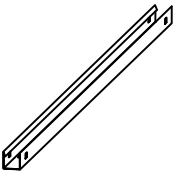
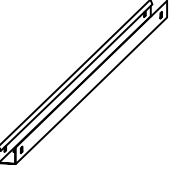
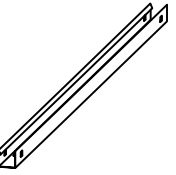
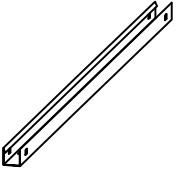
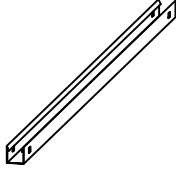
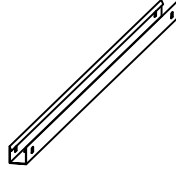
 <b>EPT1</b> x22	 <b>EP1</b> x21	 <b>EP2</b> x08
 <b>EP3</b> x02	 <b>EDP1</b> x02	 <b>EDP2</b> x02
 <b>EFU1</b> x01	 <b>EFU2</b> x01	 <b>EFU3</b> x01
 <b>EFU4</b> x02	 <b>EFU5</b> x02	 <b>EFU6</b> x01
 <b>EFU7</b> x01	 <b>EFU8</b> x01	 <b>EFB1</b> x01

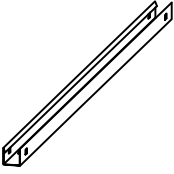
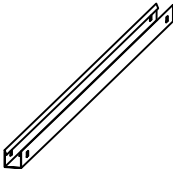
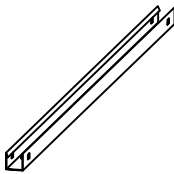
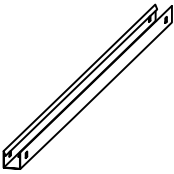
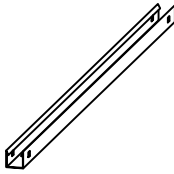
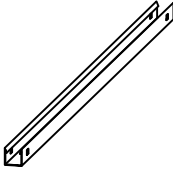
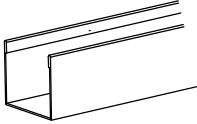
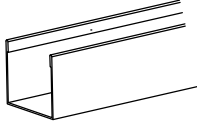
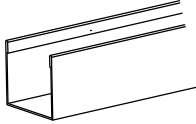
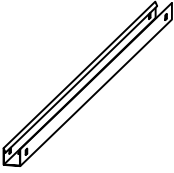
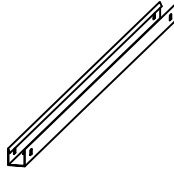
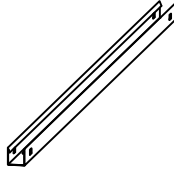
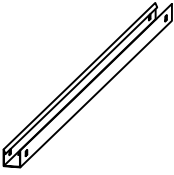
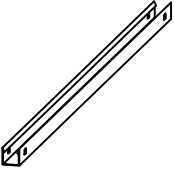
 <b>EFB2</b> ×01	 <b>EFB3</b> ×01	 <b>EFB4</b> ×04
 <b>EFB6</b> ×01	 <b>EFB7</b> ×01	 <b>EFB8</b> ×01
 <b>FM1</b> ×04	 <b>FM2</b> ×01	 <b>FM4</b> ×04
 <b>EBF2</b> ×01	 <b>EDF2</b> ×01	 <b>EDF3</b> ×01
 <b>EDF4</b> ×01	 <b>EDF5</b> ×01	

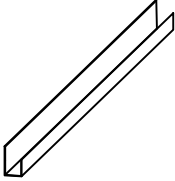
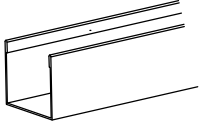
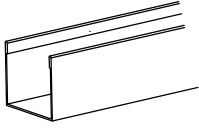
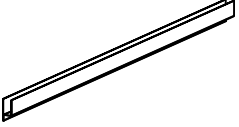
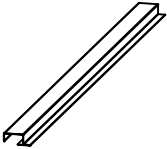
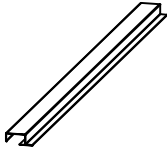
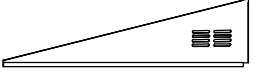
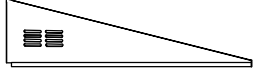
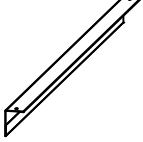
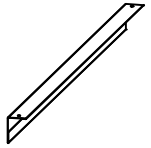
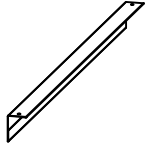
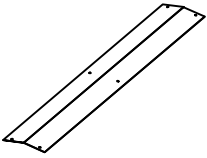
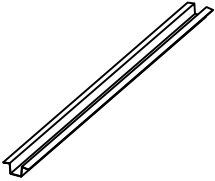
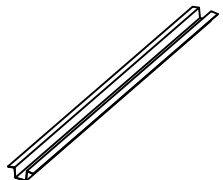
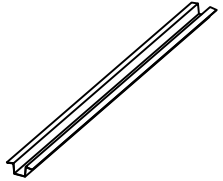
 <p><b>EDT1</b> x04</p>	 <p><b>ED1</b> x04</p>	 <p><b>ED2</b> x02</p>
 <p><b>ET1</b> x01</p>	 <p><b>ET2</b> x01</p>	 <p><b>ET3</b> x01</p>
 <p><b>EGL1</b> x02</p>	 <p><b>EGR1</b> x02</p>	 <p><b>EL1</b> x04</p>
 <p><b>EL2</b> x04</p>	 <p><b>EL3</b> x02</p>	 <p><b>ER1</b> x11</p>
 <p><b>EVJ1</b> x02</p>	 <p><b>EV1</b> x02</p>	 <p><b>EV2</b> x01</p>

**BS5** x04

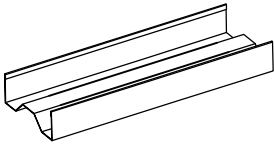

**BS4** x04

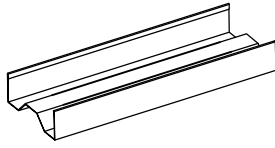

**BS6** x02

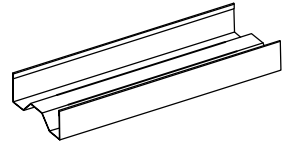

**BSM** x04

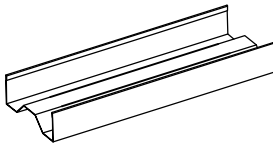



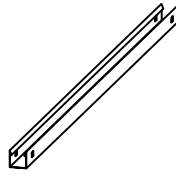





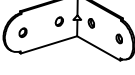



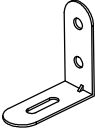

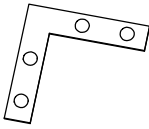

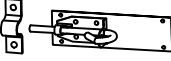
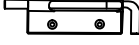
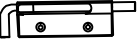
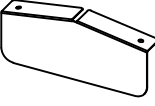

**EF1** x32

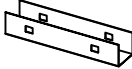
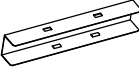

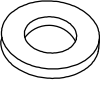
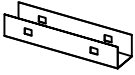

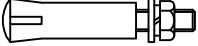
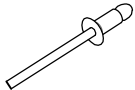
# HARDWARE

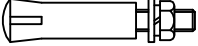
<p><b>EG1</b> x08</p> 	<p><b>C2</b> x06</p> 	<p><b>C3</b> x04</p> 	<p><b>C6</b> x20</p> 
<p><b>C7</b> x09</p> 	<p><b>C8</b> x04</p> 	<p><b>C20</b> x02</p> 	<p><b>C23</b> x04</p> 
<p><b>Waterproof tape</b> x01</p> 	<p><b>L3</b> x118</p> 	<p><b>H1</b> x01</p> 	<p><b>H2</b> x01</p> 
<p><b>H3</b> x01</p> 	<p><b>ELG</b> x02</p> 	<p><b>SH3</b> x06</p> 	<p><b>EV3</b> x02</p> 
<p><b>EV4</b> x02</p> 	<p><b>EJ1</b> x12 white</p> 	<p><b>J3</b> x02</p> 	<p><b>S3</b> x438 +2(spare)</p> 
<p><b>S5</b> x136</p> 	<p><b>EJ1</b> x16 black</p> 	<p><b>S10</b> x98 +2(spare)</p> 	<p><b>S11</b> x13</p> 
<p><b>S7</b> x08 +2(spare)</p> 	<p><b>S16</b> x08 +2(spare)</p> 	<p><b>S10</b> x98 +2(spare)</p> 	<p><b>S11</b> x13</p> 

**S18** x54  
+2(spare)



**S19** x26  
+2(spare)



**Lock** x01



**Drill bit** x01



**Gloves**



**LB** x04



**ED3** x01



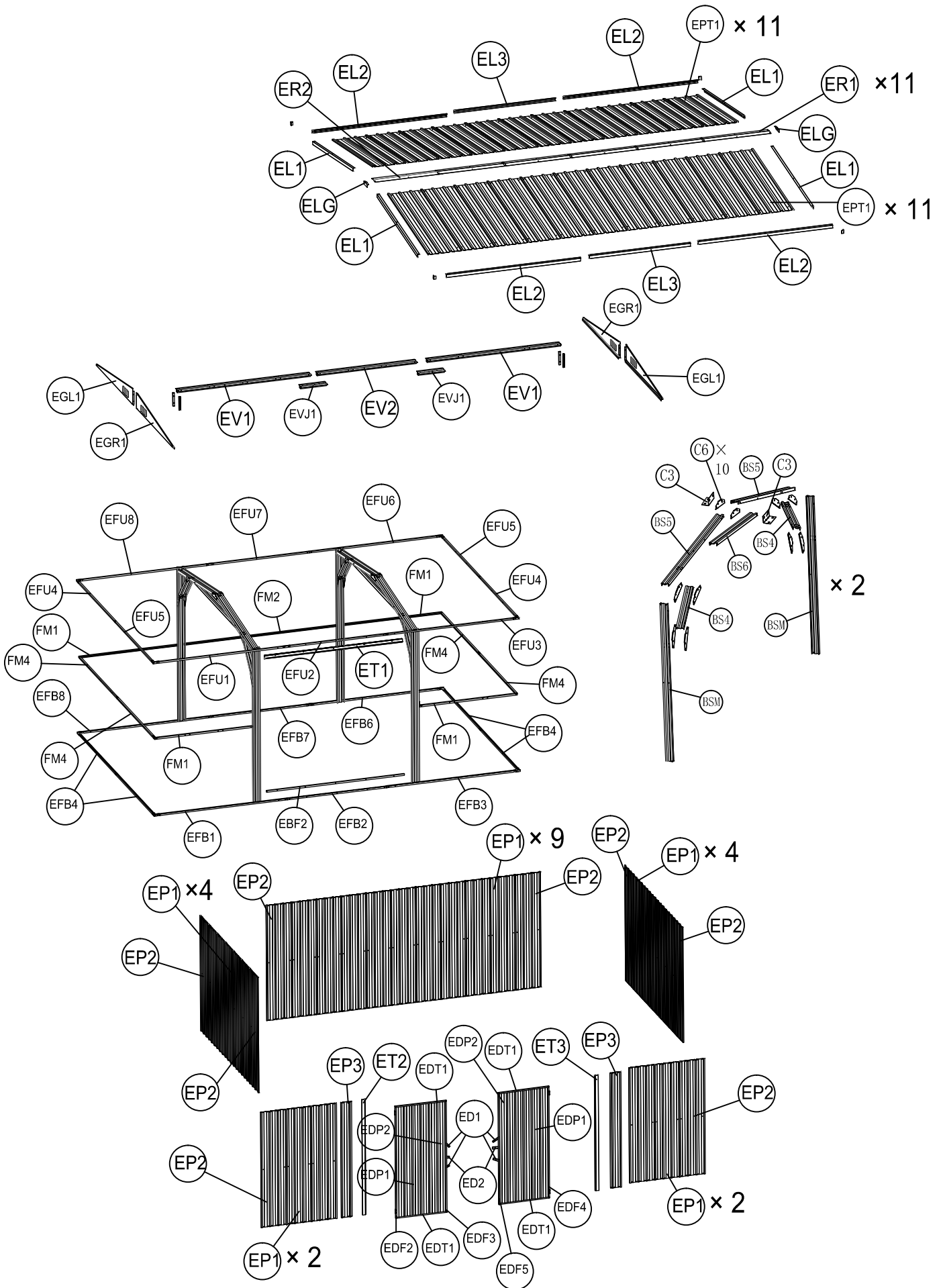

**EN** Position U channel over one end of the joined sheets, working from one end push channel down to clip onto sheets, continue to the end of the channel pushing as you go.

**FR** Positionner le rail U sur l'une des extrémités des feuilles jointes, en commençant par une extrémité, pousser le rail vers le bas pour le clipser sur les feuilles, continuer jusqu'à l'extrémité du rail en poussant au fur et à mesure.

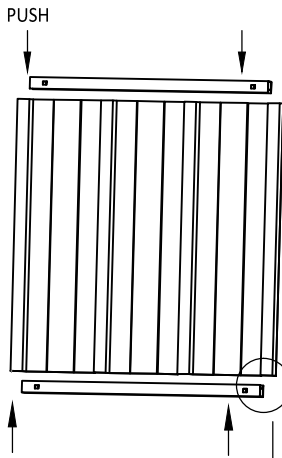

**EN** A raised platform will make assembly easier  
**FR** Une plate-forme surélevée facilite l'assemblage

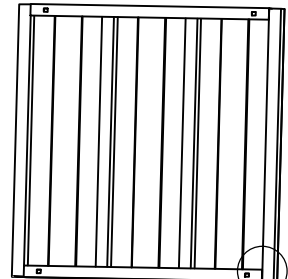
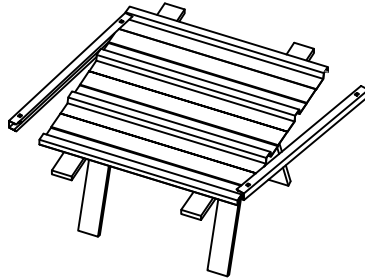

**EN** If you need to remove U channels from the panels, pull the channel along the panel from opposing ends. You may need someone to help with this.

**FR** Si vous devez retirer les profilés en U des panneaux, tirez le profilé le long du panneau à partir des extrémités opposées. Vous aurez peut-être besoin de l'aide de quelqu'un.

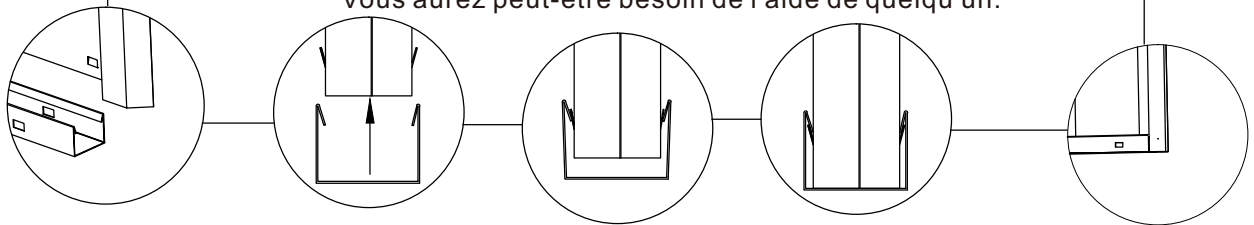

**EN** HOW TO JOIN CHANNELS (where needed)

**FR** COMMENT JOINDRE LES CANAUX (si nécessaire)

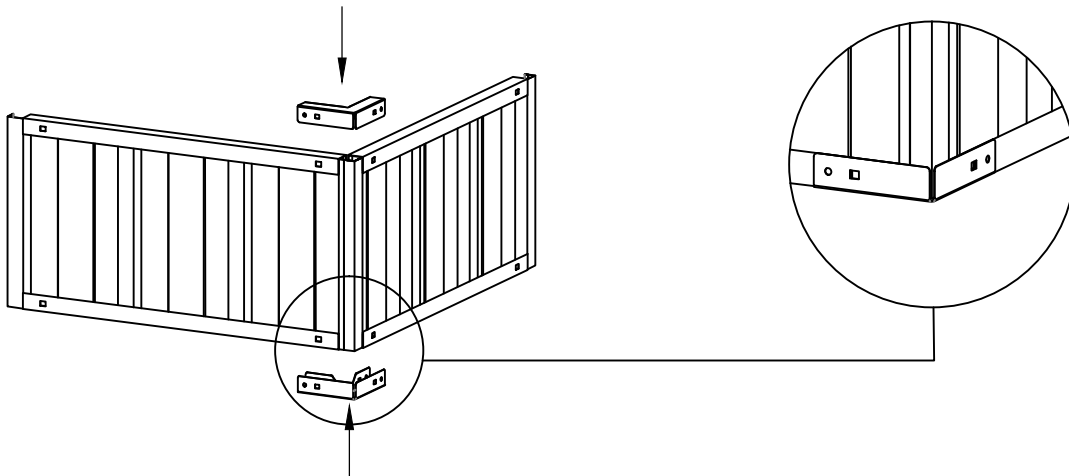
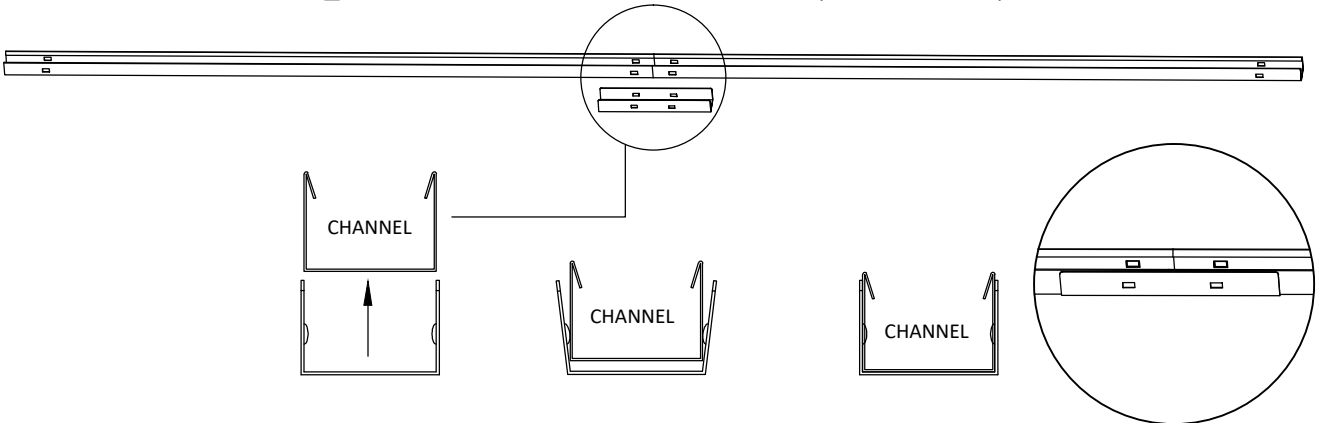



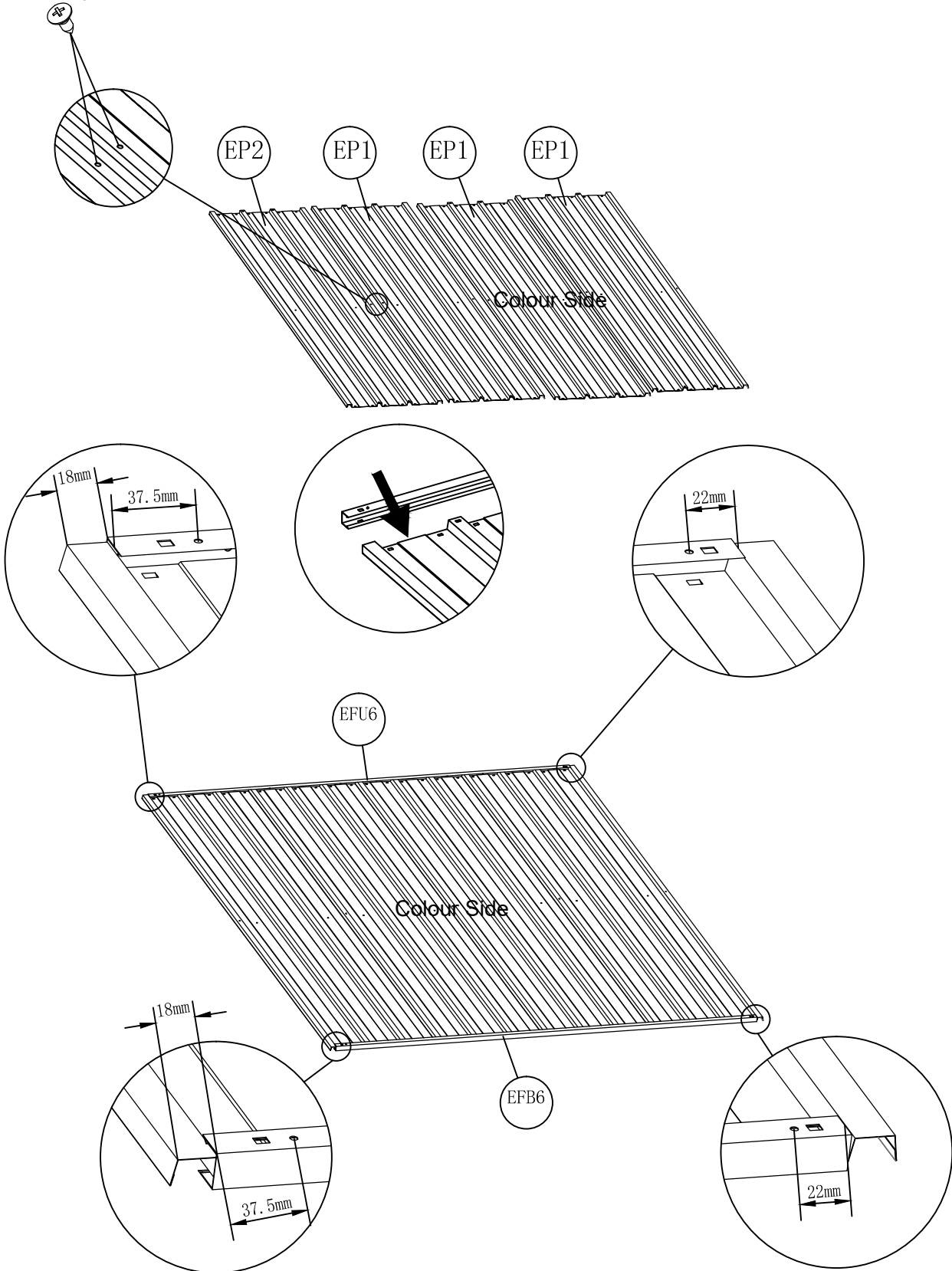

# PART A

	EP1	3		EP2	1		EFU6	1		EFB6	1		S3	3
---	-----	---	---	-----	---	---	------	---	---	------	---	---	----	---

Hole alignment



# PART B

	EP1	3		EFU7	1		EFB7	1		S3	2
---	-----	---	---	------	---	---	------	---	---	----	---

Hole alignment

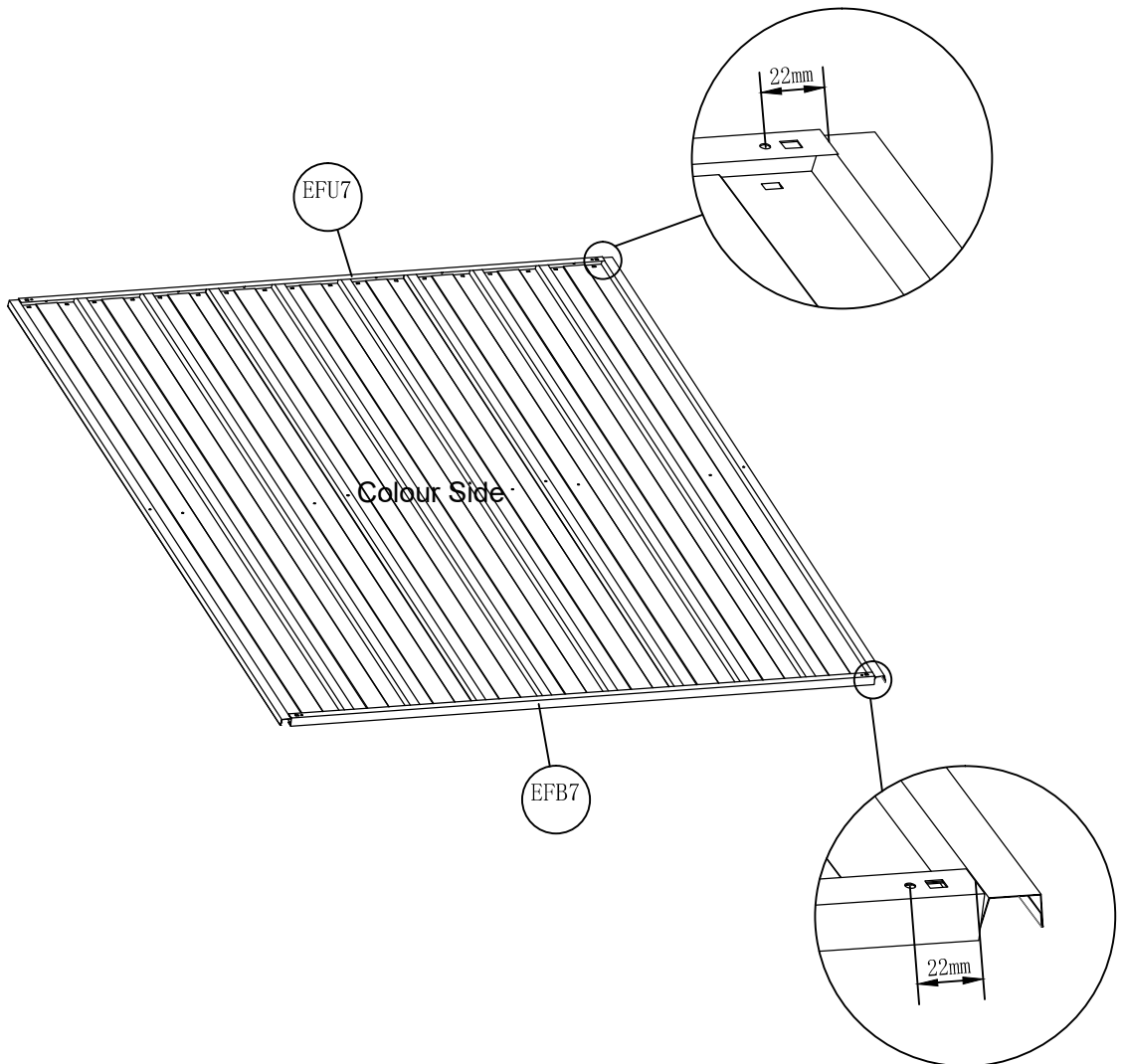
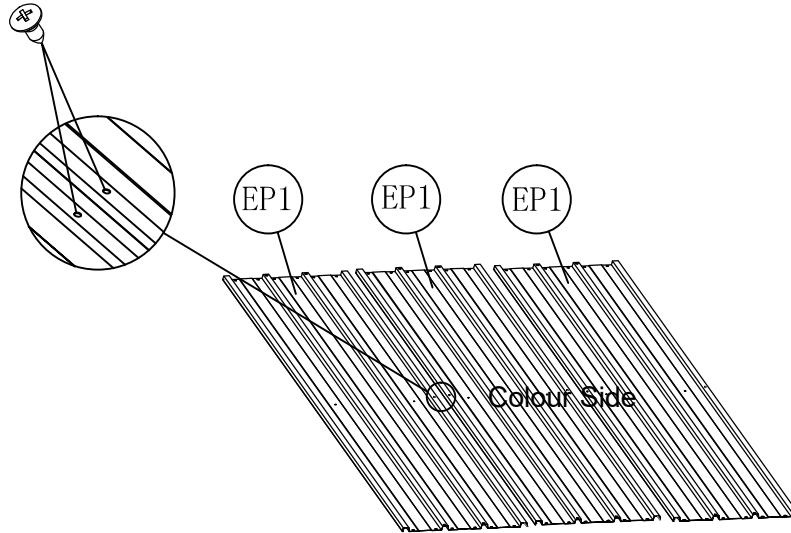

# PART C

	EP1	3		EP2	1		EFU8	1		EFB8	1		S3	3
---	-----	---	---	-----	---	---	------	---	---	------	---	---	----	---

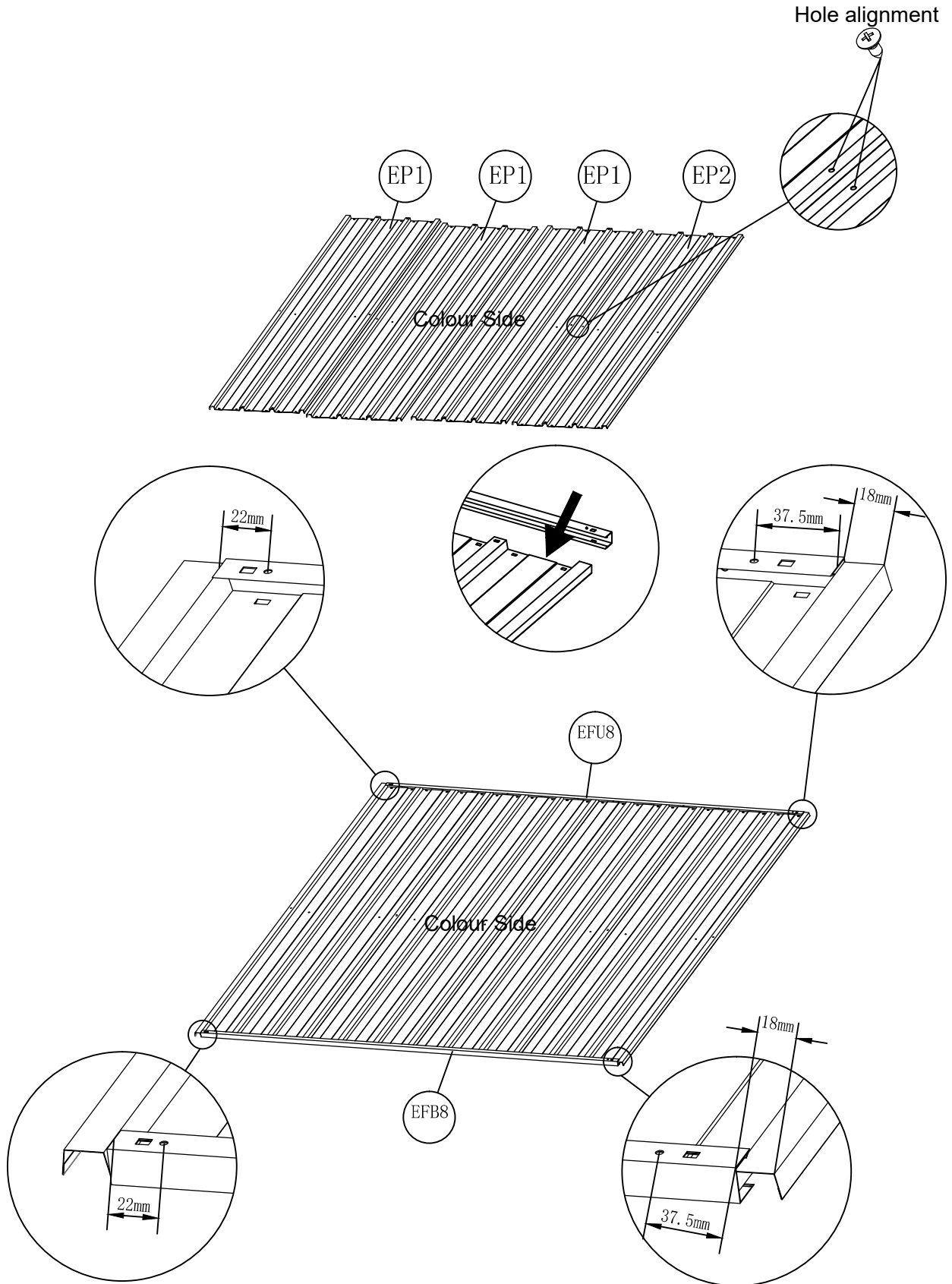

# PART D

	EP1	2		EP2	1		EFU4	1		EFB4	1		S3	2
---	-----	---	---	-----	---	---	------	---	---	------	---	---	----	---

X 2

Hole alignment

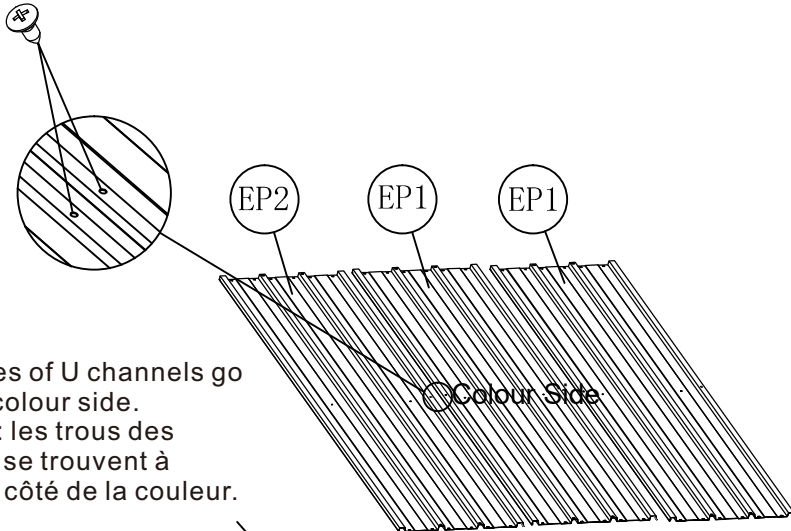

**EN\_Tip:** Holes of U channels go on inside of colour side.

**FR\_Conseil :** les trous des profilés en U se trouvent à l'intérieur du côté de la couleur.

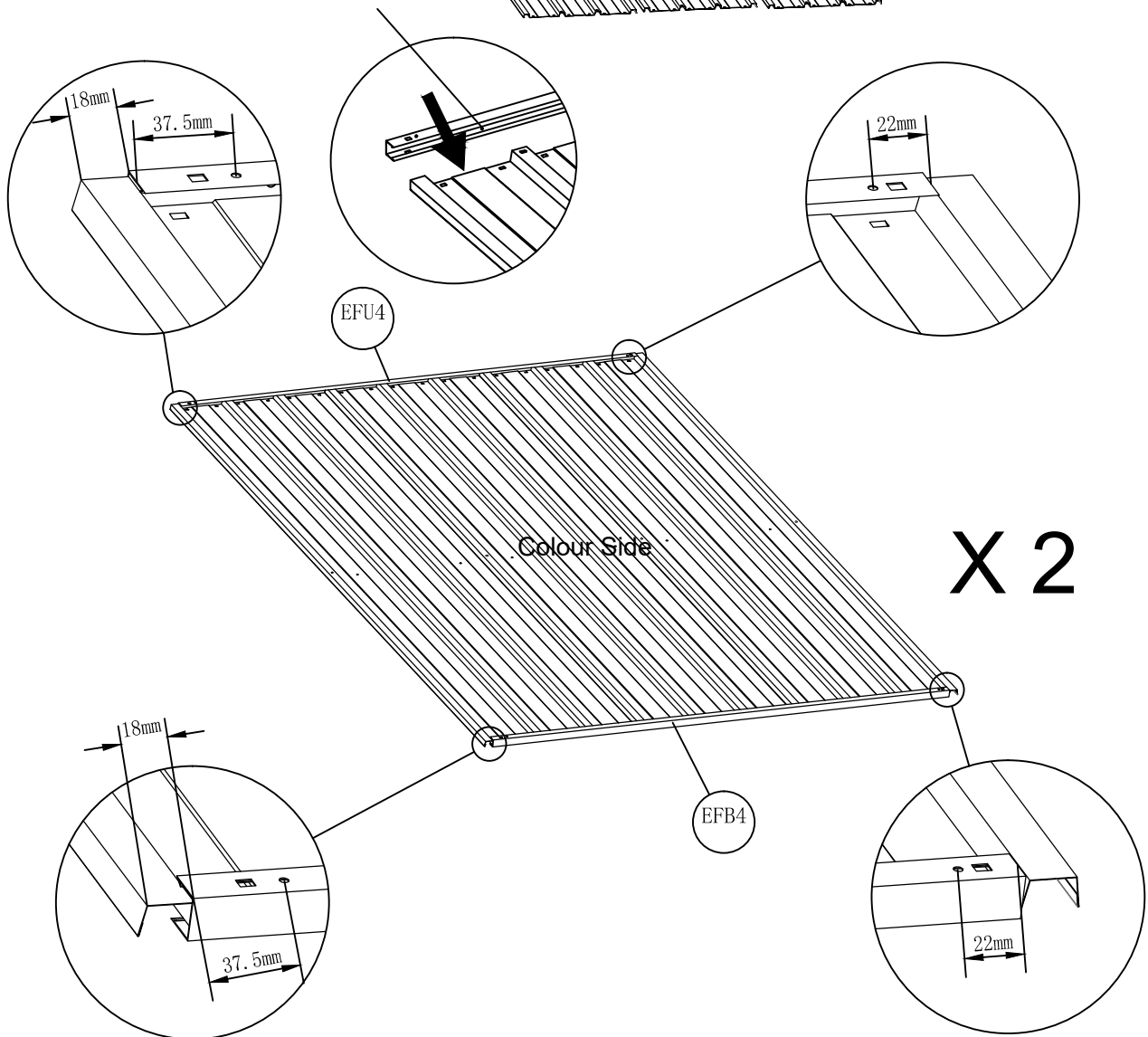



# PART E

	EP1	2		EP2	1		EFU5	1		EFB4	1		S3	2
---	-----	---	---	-----	---	---	------	---	---	------	---	---	----	---

# X 2

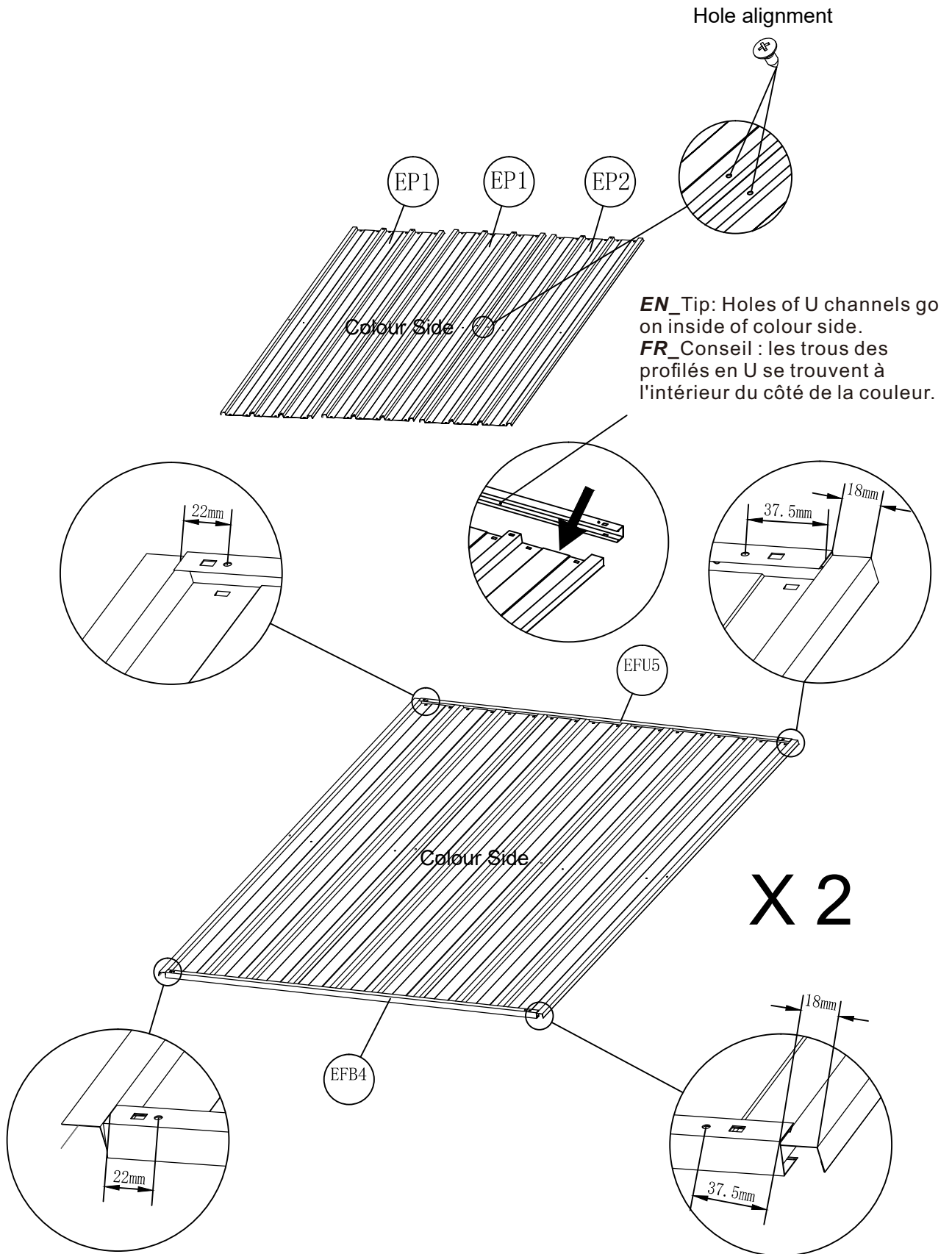

# PART F

	EP1	2		EP2	1		EP3	1		EFU1	1		EFB1	1
Hole alignment													S3	3

Hole alignment

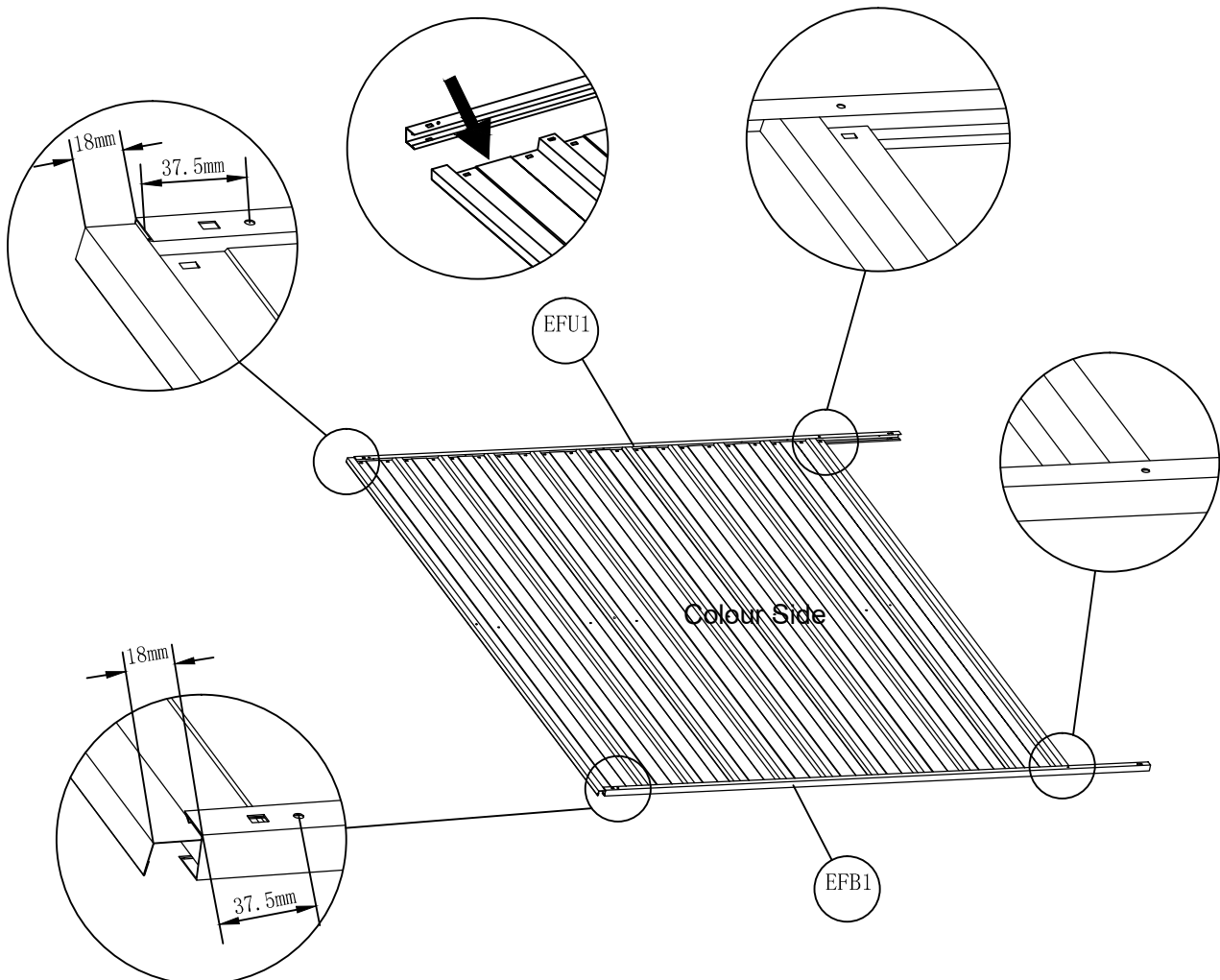
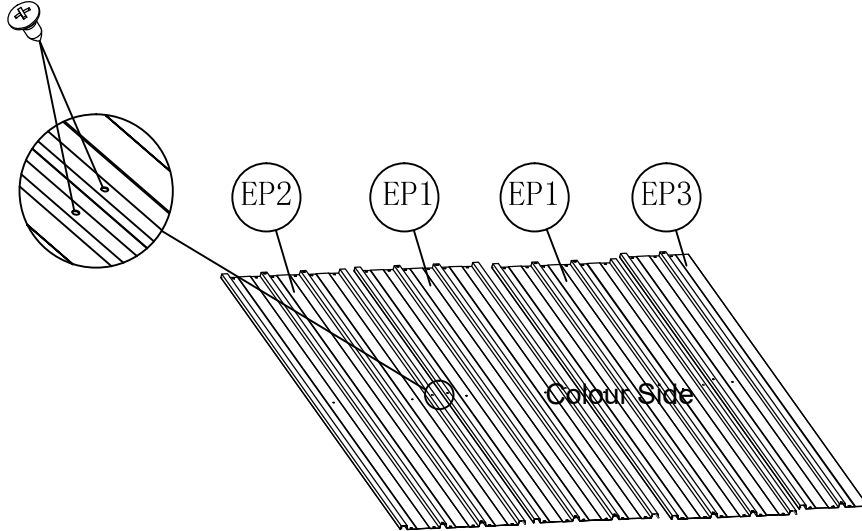





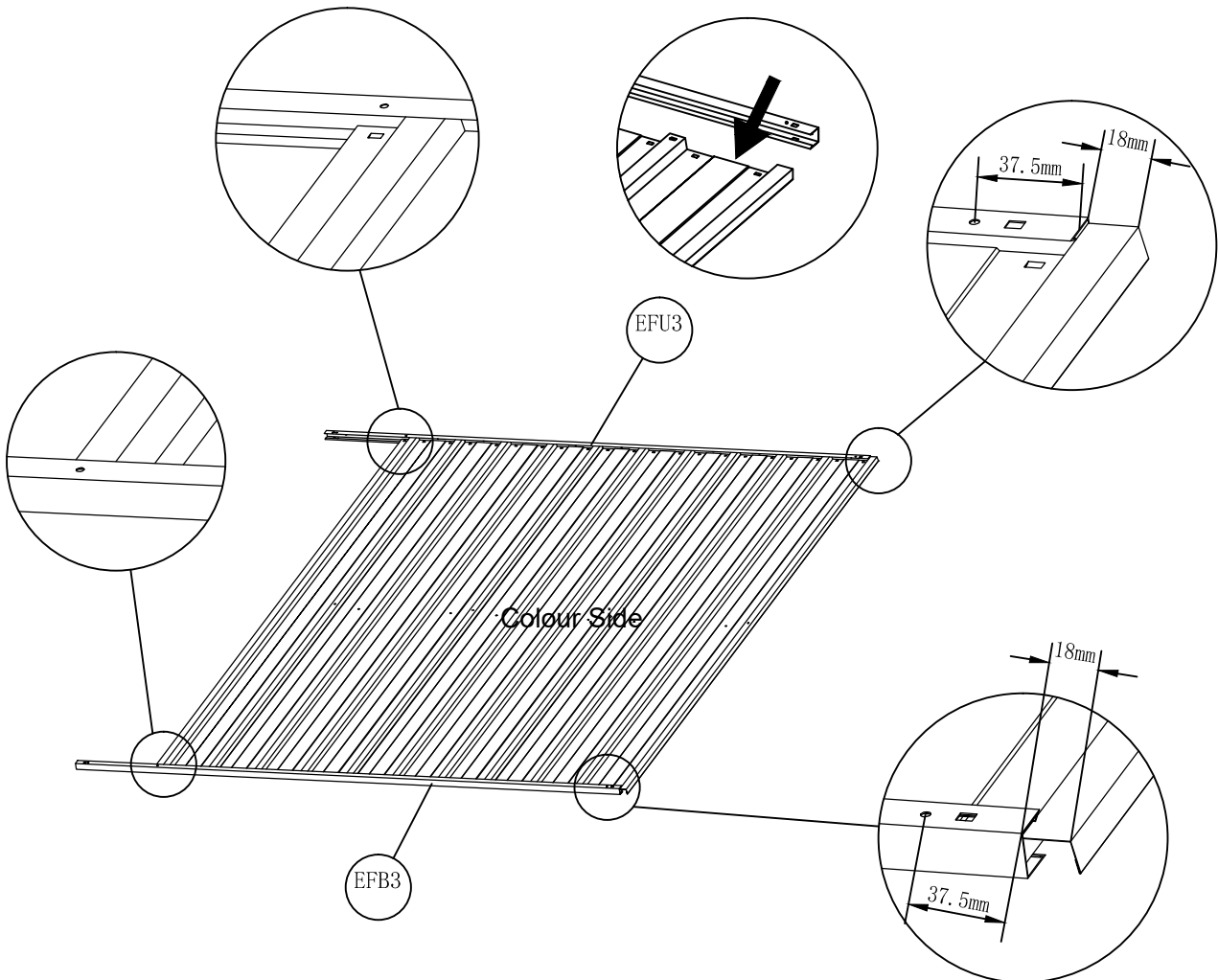
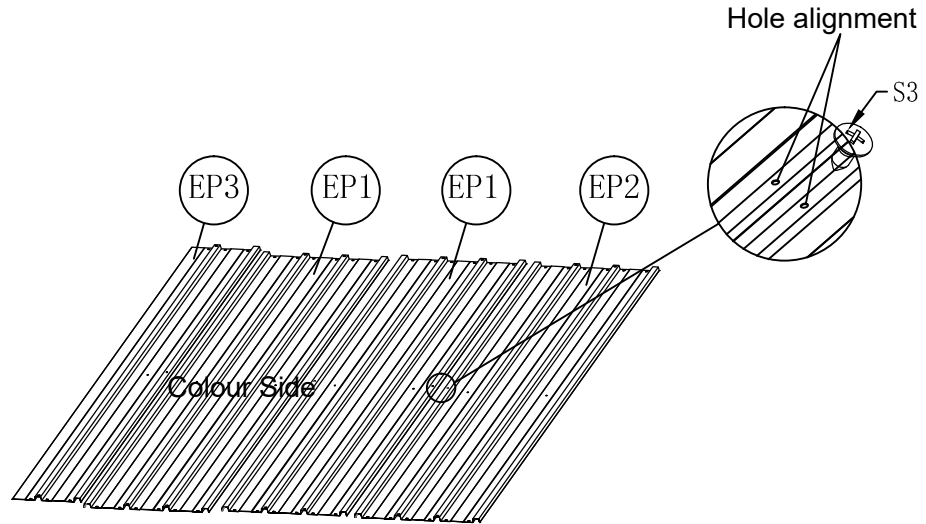





# PART G

	EP1	2		EP2	1		EP3	1		EFU3	1		EFB3	1
	S3	3												



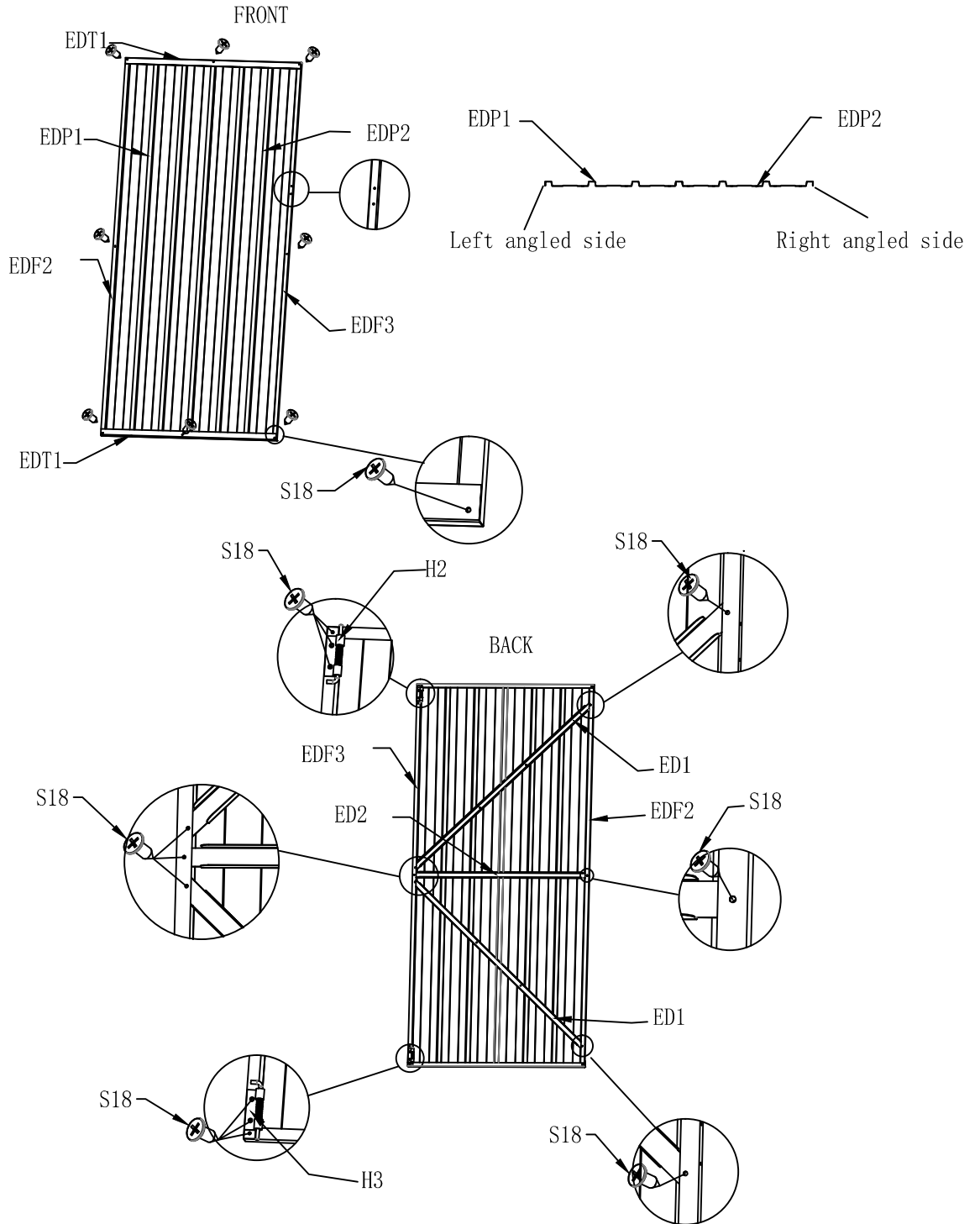

# SHED ASSEMBLY LEFT DOOR

	EDP1	1		EDP2	1		EDT1	2		EDF2	1		EDF3	1
	ED1	2		ED2	1		H2	1		H3	1		S18	28



# SHED ASSEMBLY LEFT DOOR

	SH3	3		S19	6
---	-----	---	---	-----	---

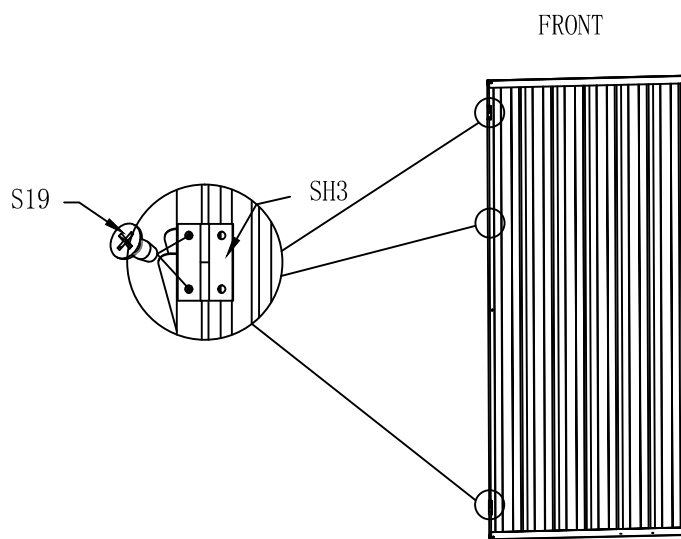

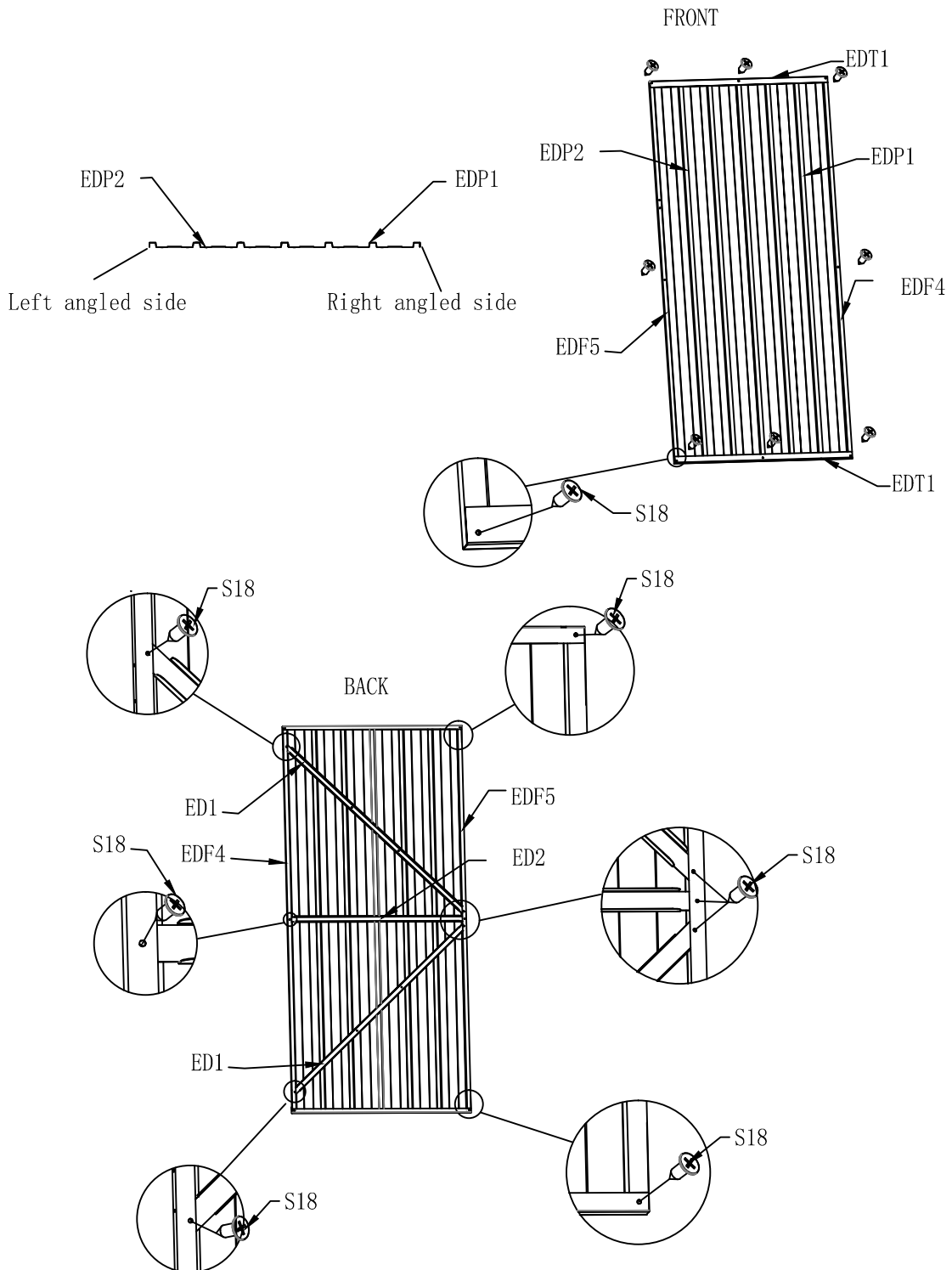

# SHED ASSEMBLY RIGHT DOOR

	EDP1	1		EDP2	1		EDT1	2		EDF4	1		EDF5	1
	ED1	2		ED2	1		S18	24						







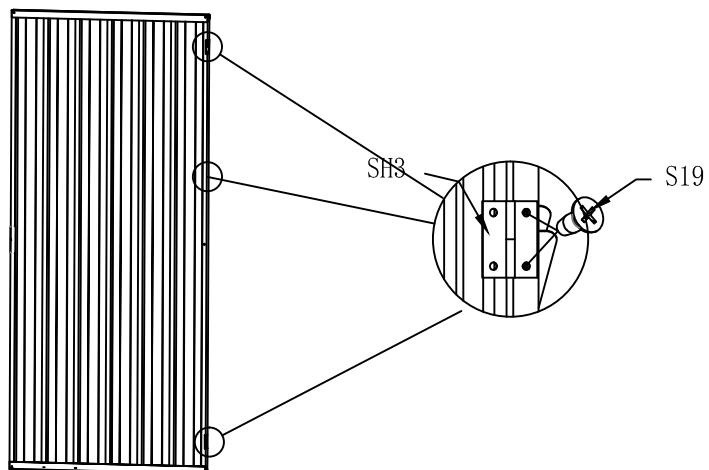

# SHED ASSEMBLY RIGHT DOOR

	SH3	3		S19	6
---	-----	---	---	-----	---

FRONT



# Supports

	BSM	2		BS4	2		BS5	2		BS6	1
	S10	48		C6	10						

**X 2**

**EN\_** Put bolts through the pre-drilled holes, use washer and nuts, but do not tighten at step1-3.

**FR\_** Introduire les boulons dans les trous préperçés, utiliser les rondelles et les écrous, mais ne pas serrer à l'étape 1-3.

## STEP 1

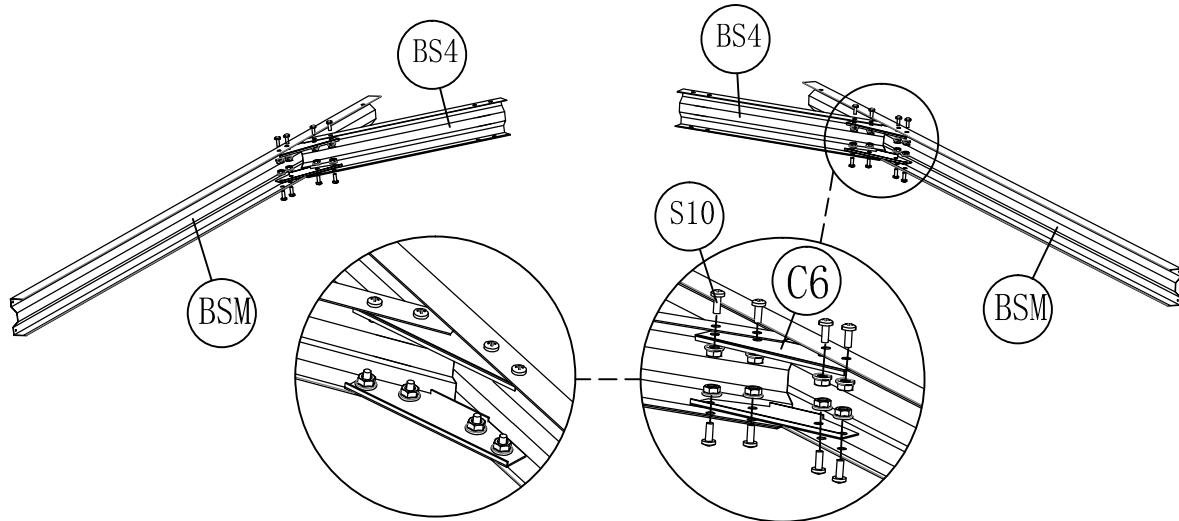

## STEP 2

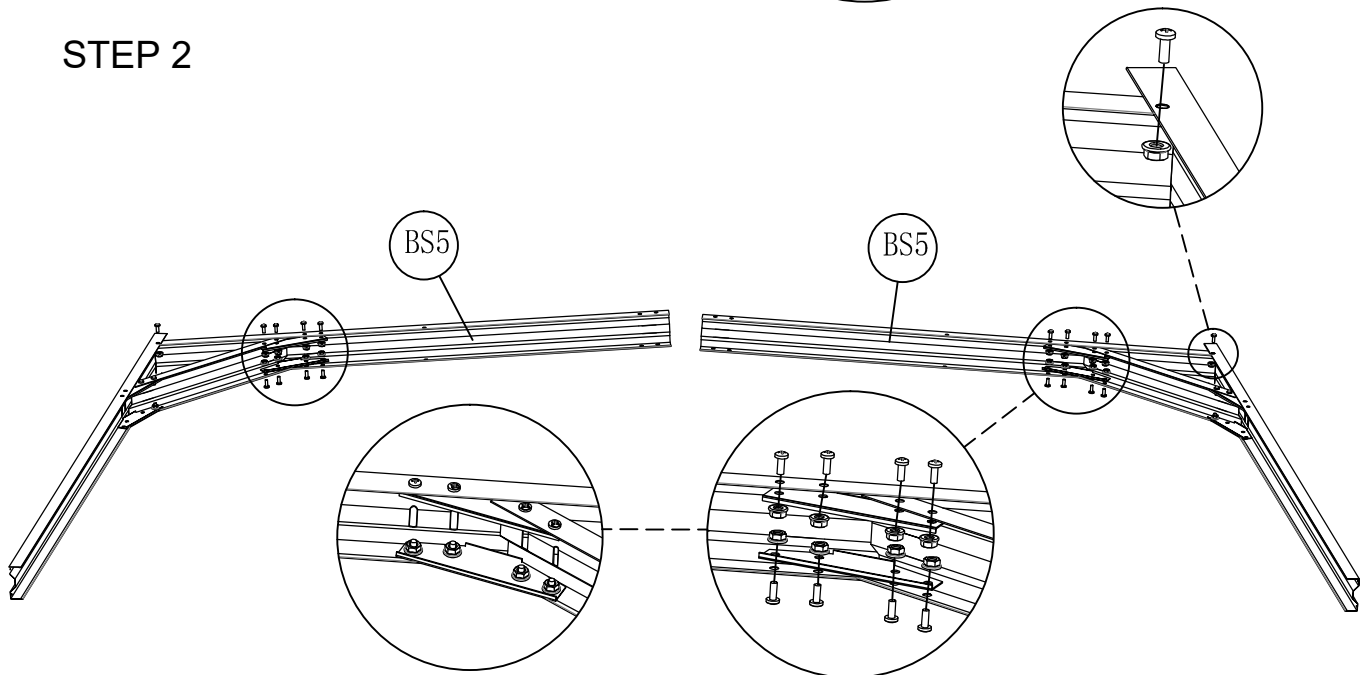



# Supports

STEP 3

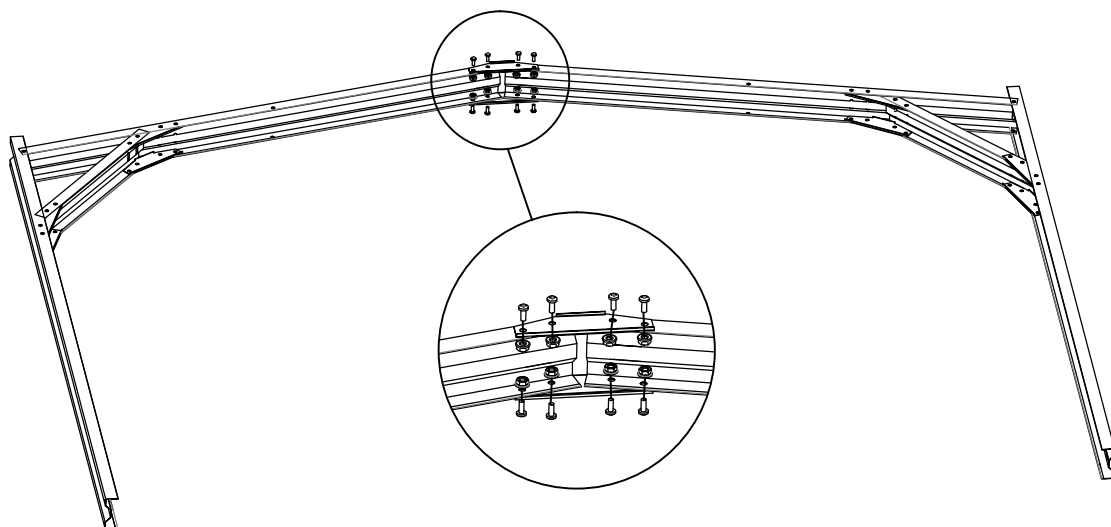



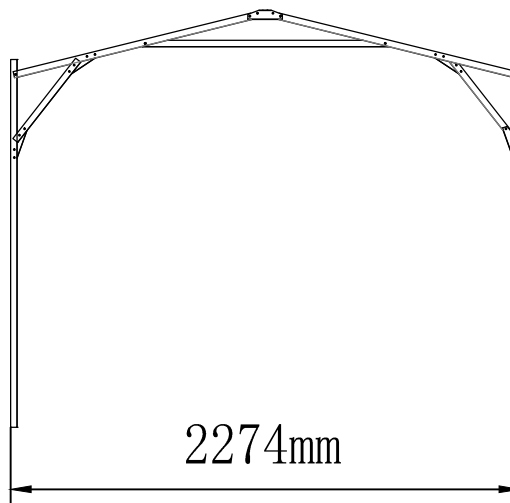
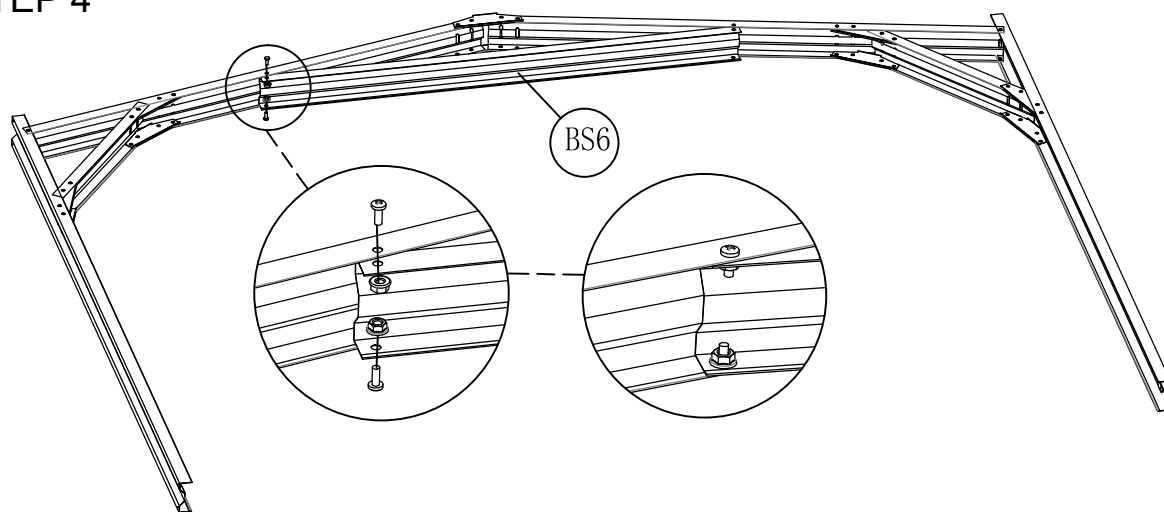

*EN*\_Tighten all the screws, at this stage.  
*FR*\_A ce stade, serrez toutes les vis.

STEP 4



X 2

# MAIN BEAM

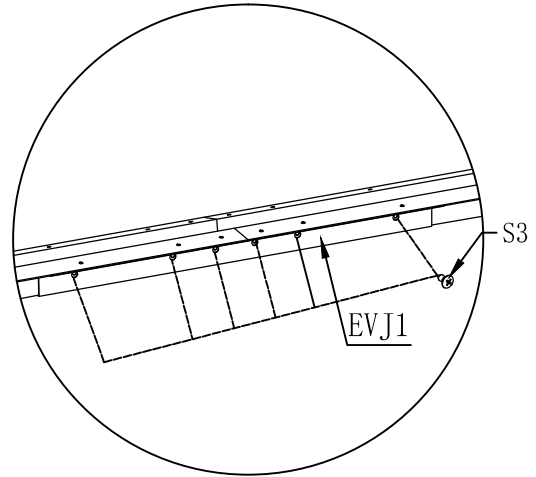
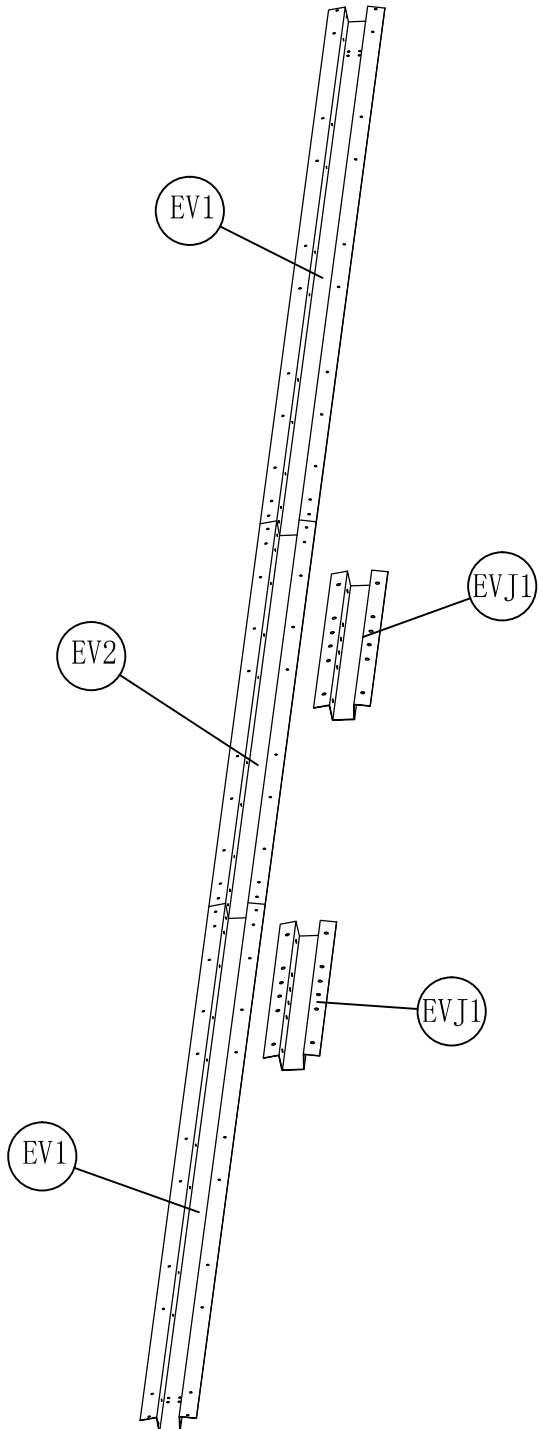

	EV1	2		EV2	1		EVJ1	2		S3	24
---	-----	---	---	-----	---	---	------	---	--	----	----



## Walls Assembly

**EN** Ensure the correct location of up and down, when you install walls.

**FR** Veillez à l'emplacement correct du haut et du bas lorsque vous installez des murs.

	EG1	2		S3	8
---	-----	---	---	----	---



**EN** Noted: S3 on both sides to improve the stability of connector

**FR** Noté : S3 des deux côtés pour améliorer la stabilité du connecteur

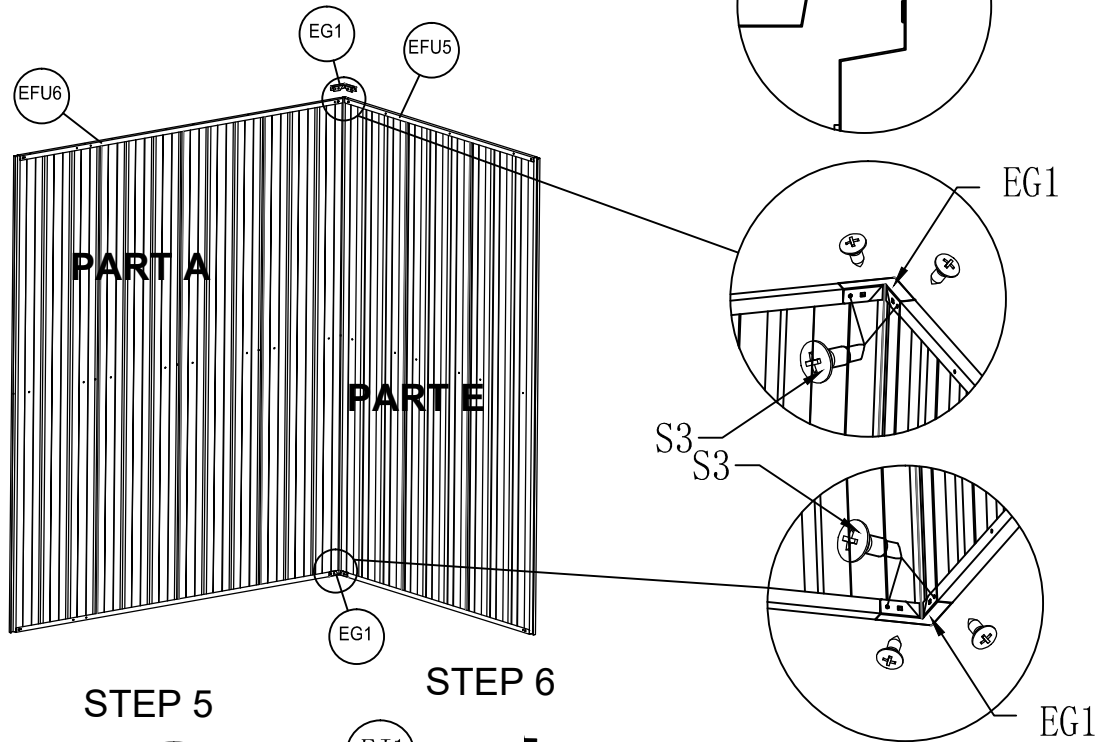

**STEP 4**

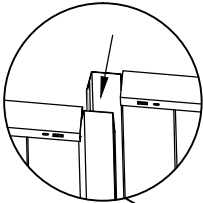

**STEP 5**

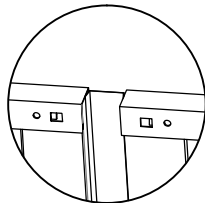

**STEP 6**

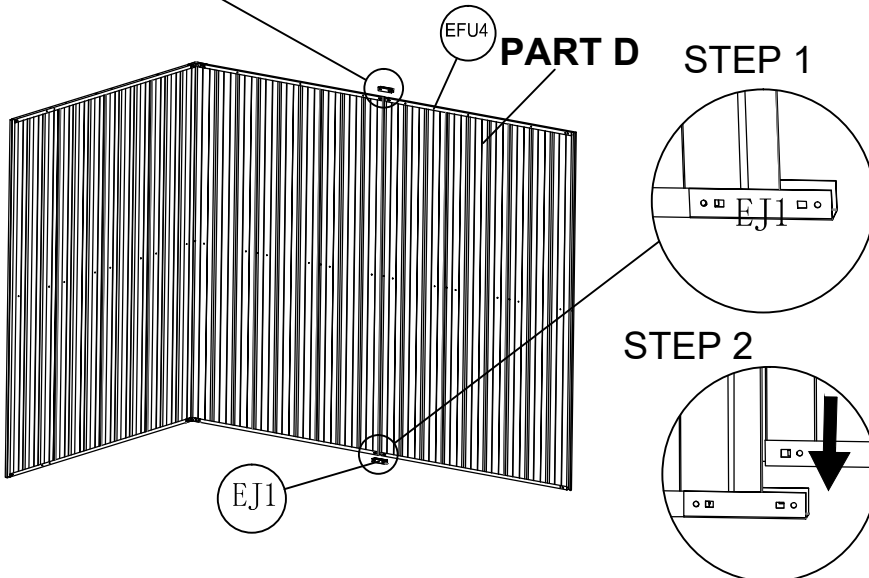
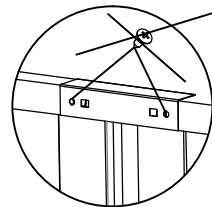
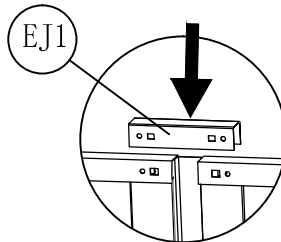

**STEP 1**

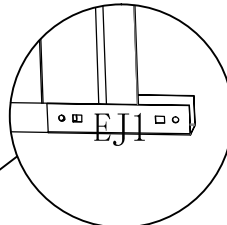

**STEP 2**

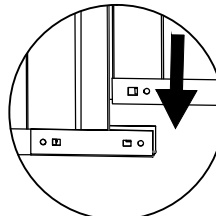

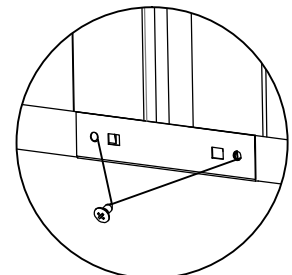

**STEP 3**



	EJ1	2
white		
	S3	8

# Walls Assembly

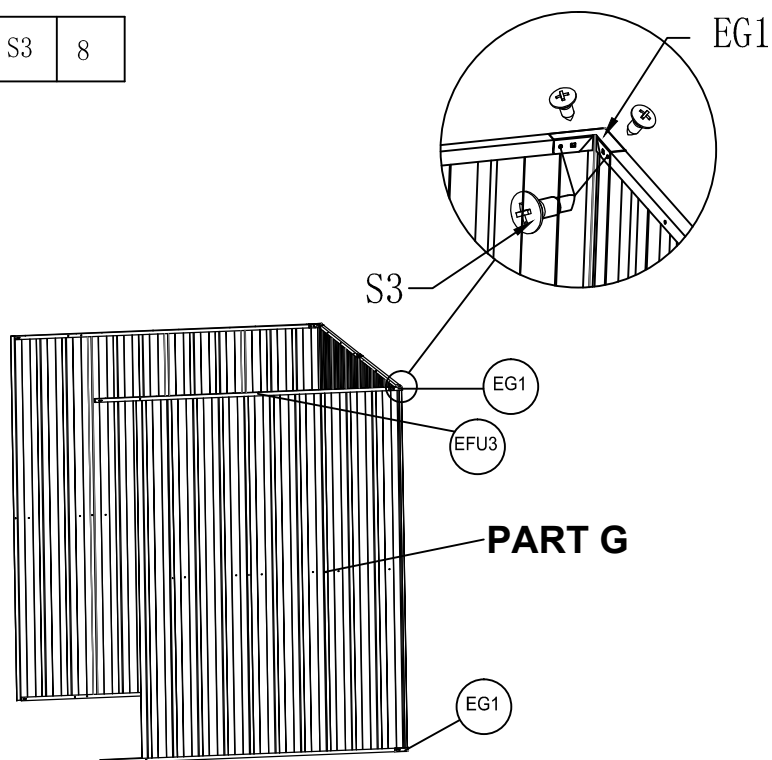

	EG1	2		S3	8
---	-----	---	---	----	---

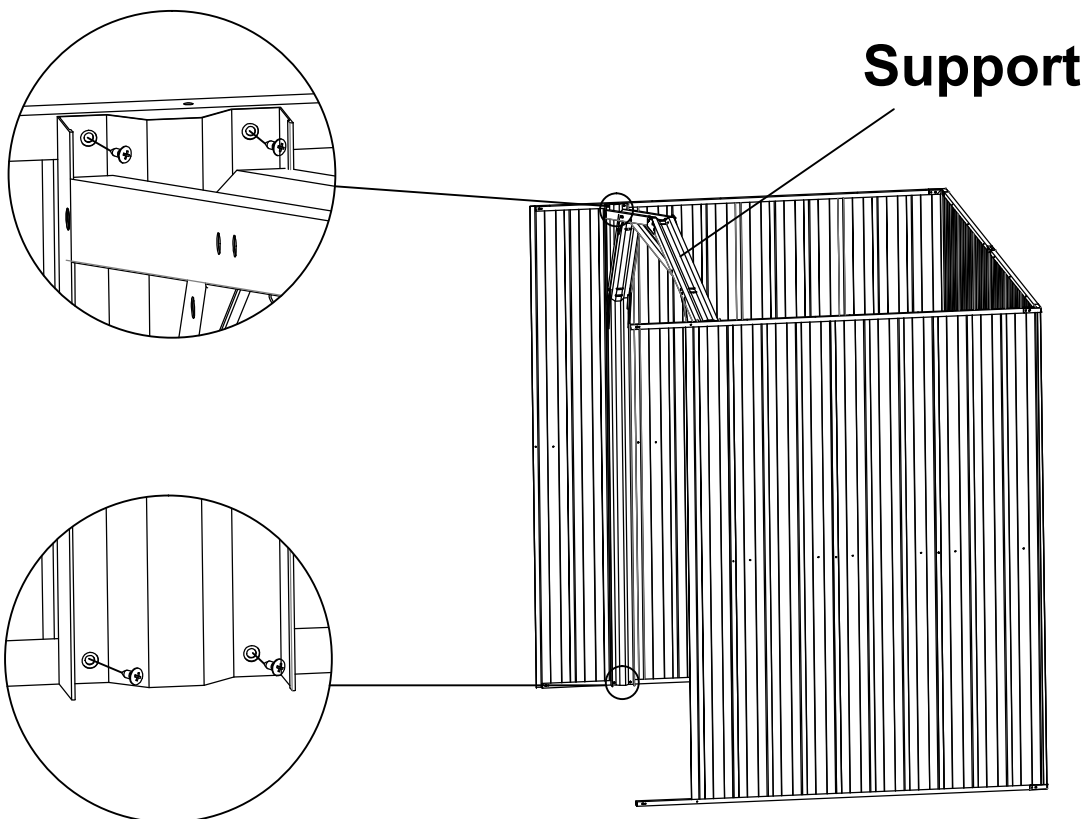

	S3	8
---	----	---



# Walls Assembly

 white	EJ1	4		S3	16
---	-----	---	---	----	----

STEP 1

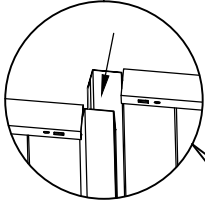

STEP 2

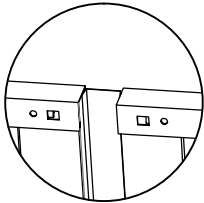

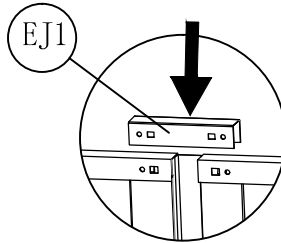

STEP 3

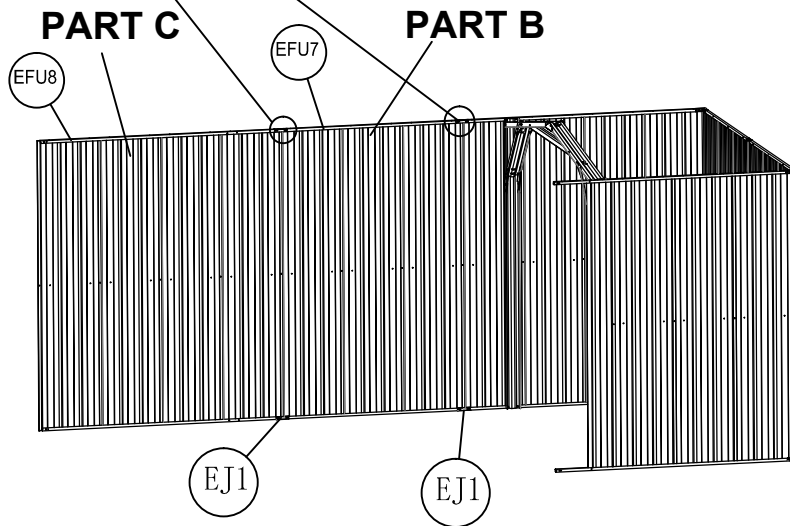
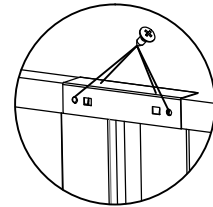

STEP 4



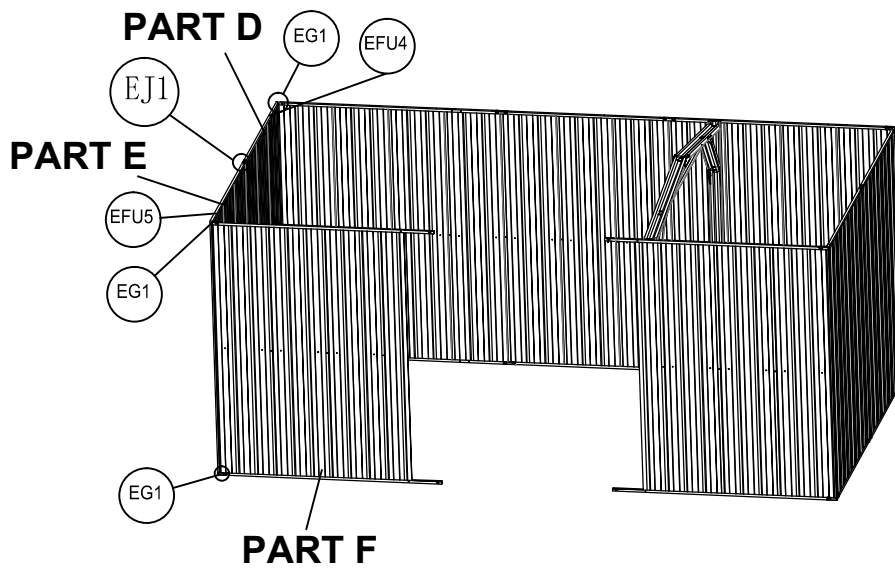

	EG1	4	 white	EJ1	2		S3	24
---	-----	---	---	-----	---	---	----	----

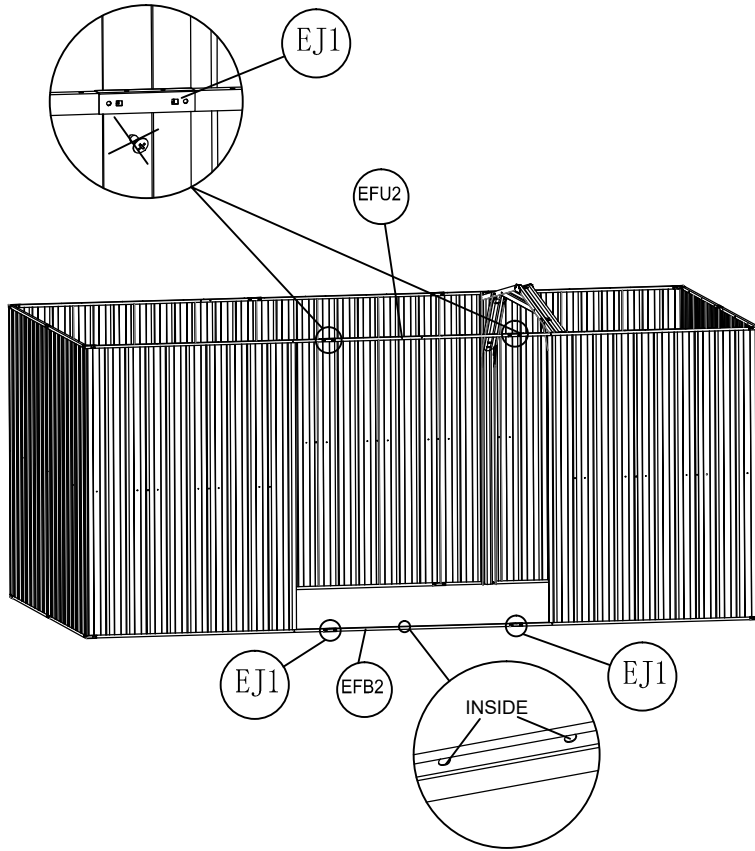

## Walls Assembly

 white	EJ1	4		EFU2	1		EFB2	1
---	-----	---	---	------	---	---	------	---



	S3	8
---	----	---

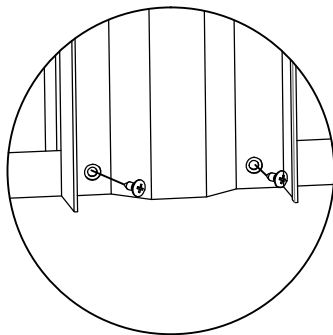
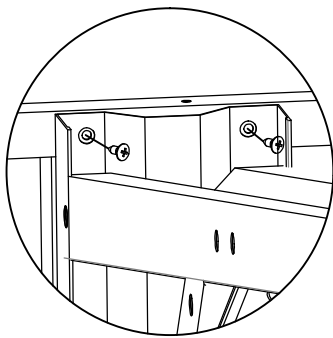



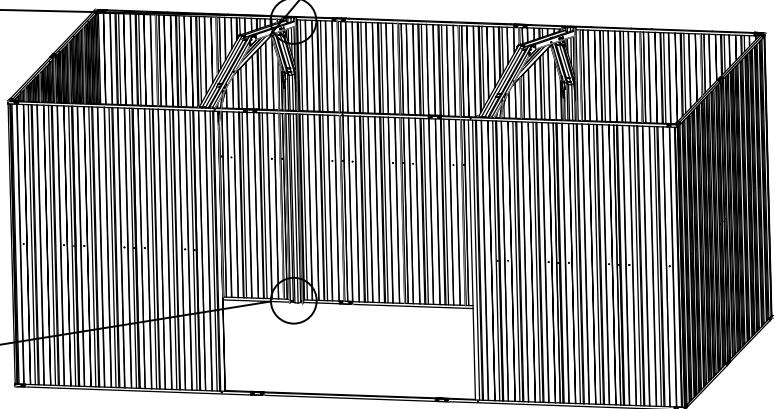

Support

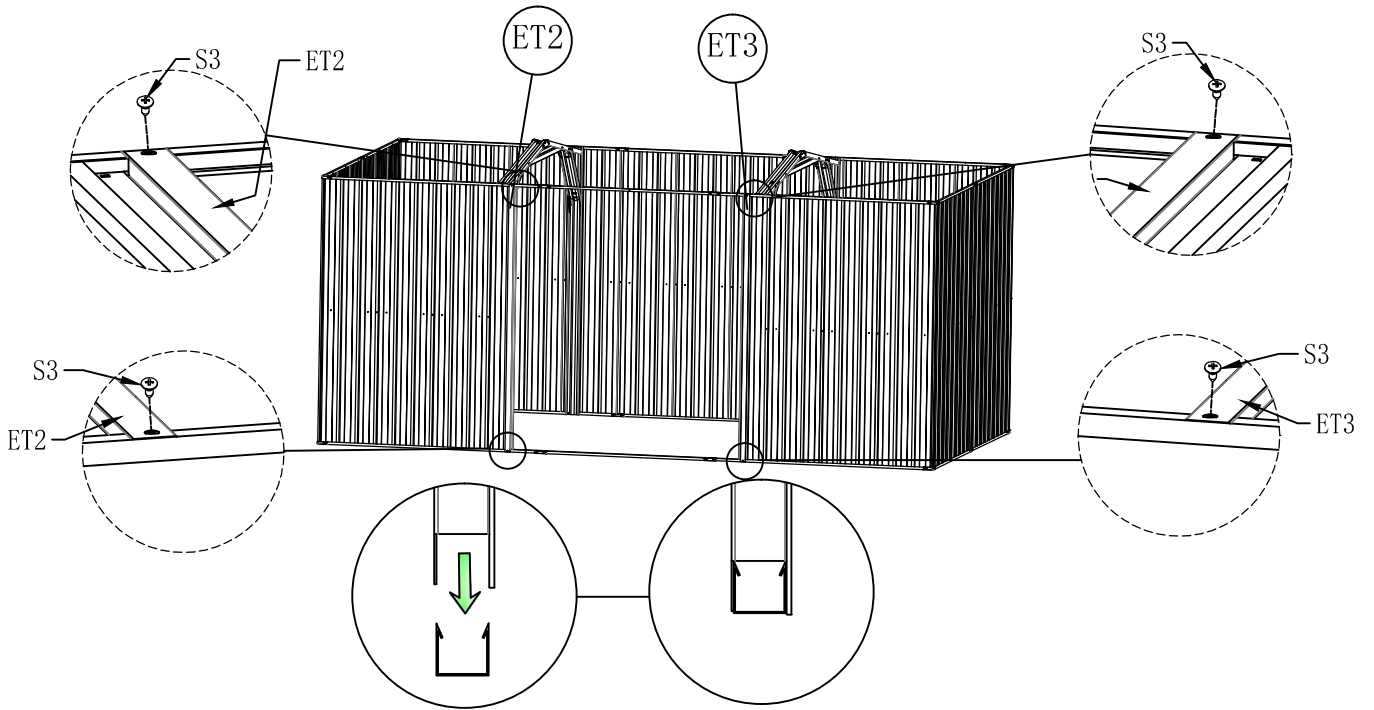

# Walls Assembly

	ET2	1		ET3	1		S3	4
---	-----	---	---	-----	---	---	----	---







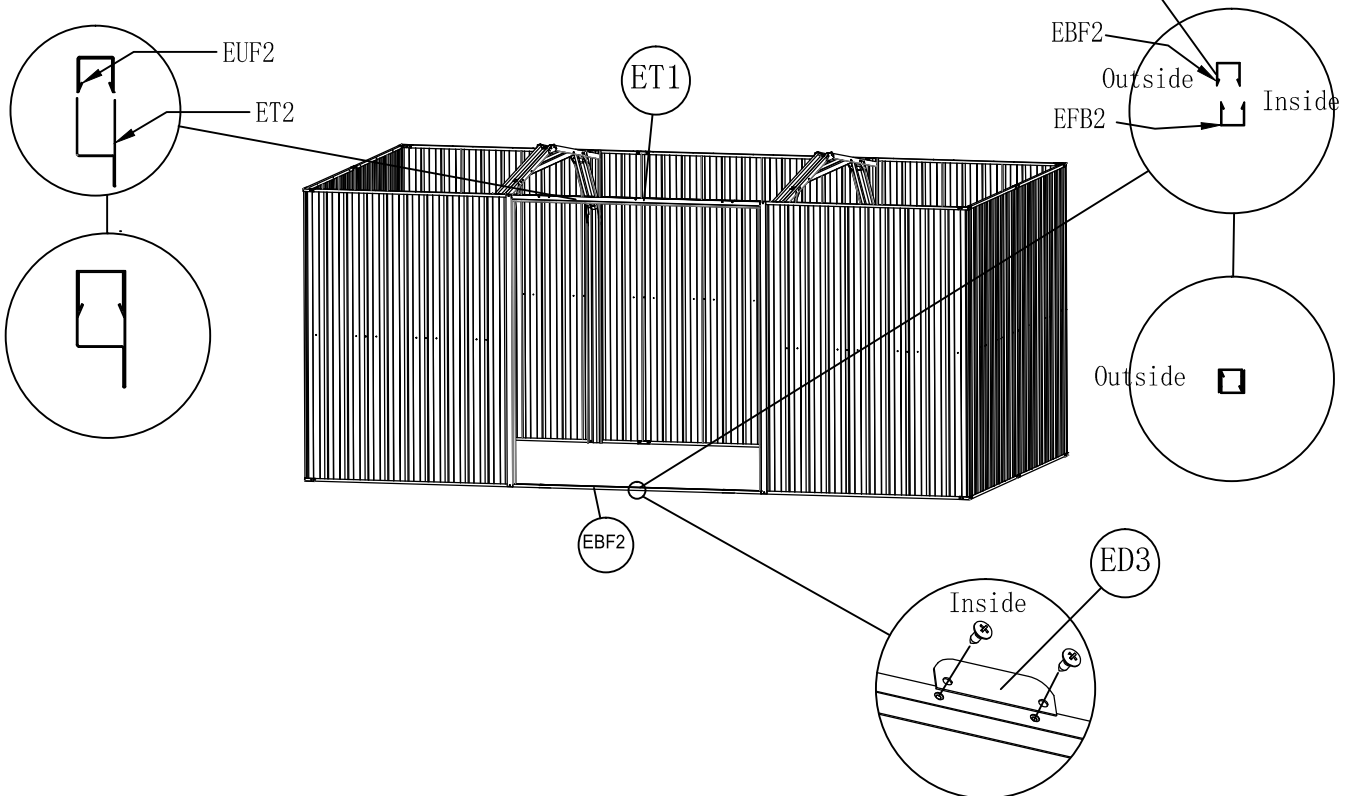



	ET1	1		EBF2	1		S3	14		ED3	1
---	-----	---	---	------	---	---	----	----	--	-----	---

**EN** There are no holes outside.  
**FR** Il n'y a pas de trous à l'extérieur.





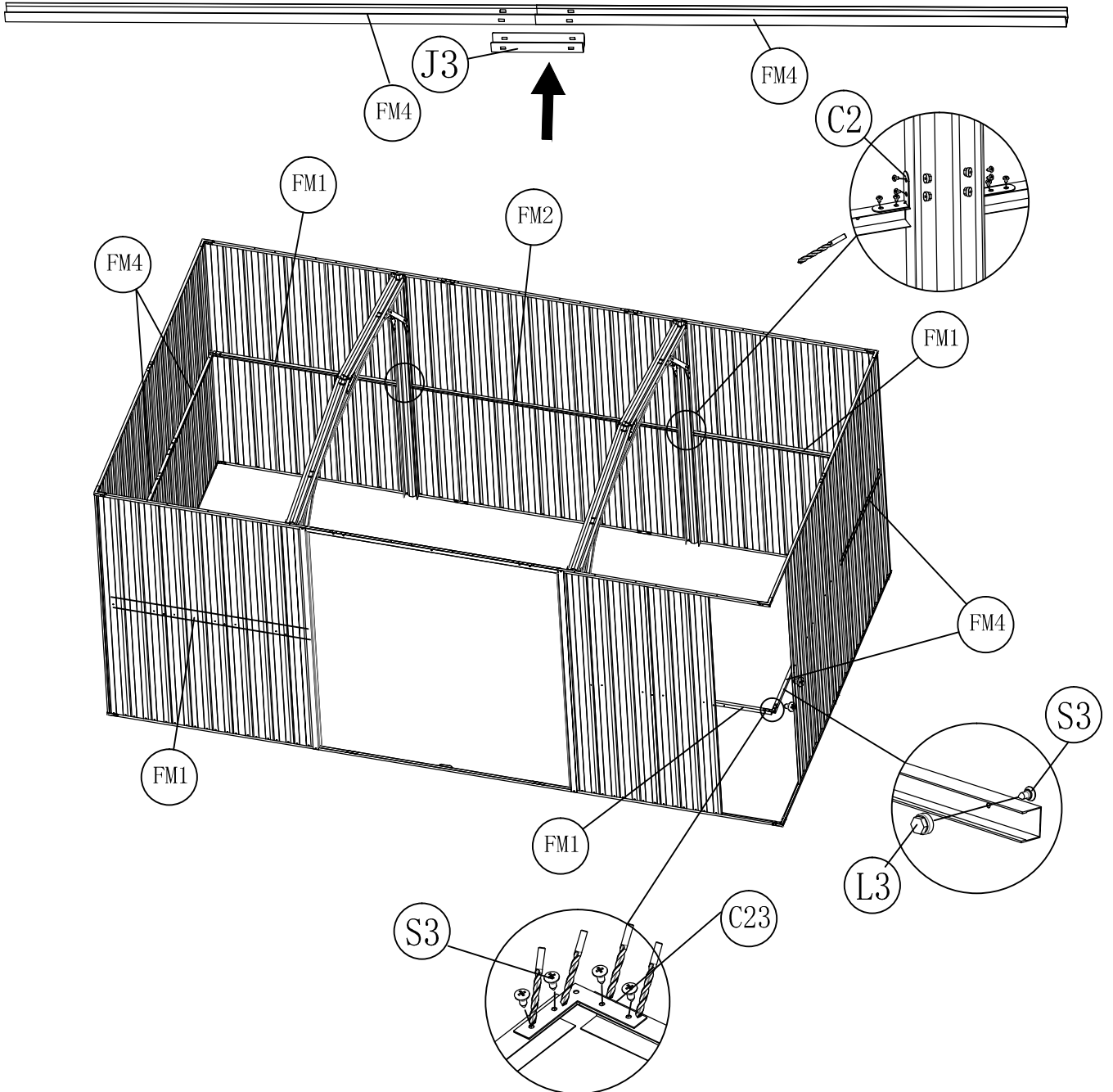

# Support Assembly

	FM1	4		FM2	1		FM4	4		J3	2
	S3	98		L3	70		C2	6		C23	4





# Anchoring Assembly

	C7	9		S11	13		C8	4		S3	8
---	----	---	---	-----	----	---	----	---	--	----	---

## STEP1

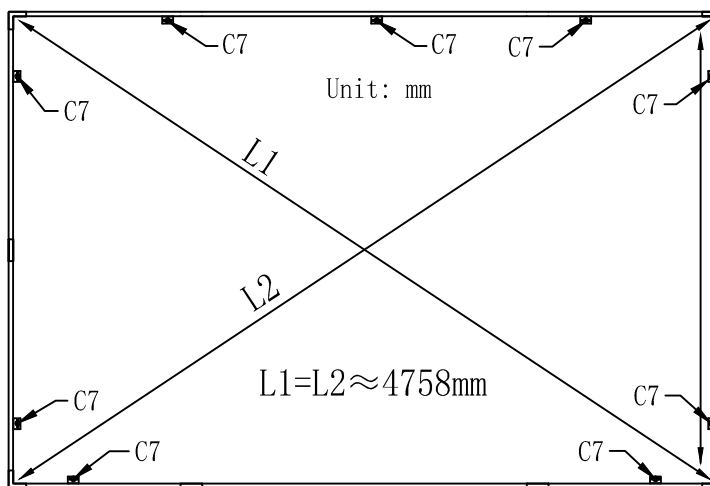

## SUPPORT

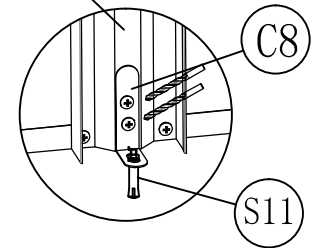

C7

- EN\_1.** The shed is now free standing. It is critical at this stage to ensure the shed is levelled.  
 2. Then measure the diagonal distance and make sure the four side walls are squared to 90 degrees.  
 3. Use anchor kit (C7 & S11) when fixing to a concrete base. Fastening the anchor kit onto a concrete pad  
 3.1 Mark the place of the anchor on the ground.  
 3.2 Use 10mm -0.39" concrete drill bit and drill holes 60mm-2.4" deep.  
 3.3 Tap concrete fixing bolts into the hole, place anchor, add washer and nut and fasten.

- FR\_1.** l'abri est maintenant libre. Il est essentiel à ce stade de s'assurer que l'abri est de niveau.  
 2) Mesurez ensuite la distance diagonale et assurez-vous que les quatre murs latéraux sont équarris à 90 degrés.  
 3. utilisez le kit d'ancrage (C7 et S11) pour la fixation sur une base en béton. Fixation du kit d'ancrage sur un socle en béton  
 3.1 Marquez l'emplacement de l'ancrage sur le sol.  
 3.2 Utilisez une mèche à béton de 10 mm et percez des trous de 60 mm de profondeur.  
 3.3 Tapez les boulons de fixation pour béton dans le trou, placez l'ancrage, ajoutez la rondelle et l'écrou et fixez.

## STEP2

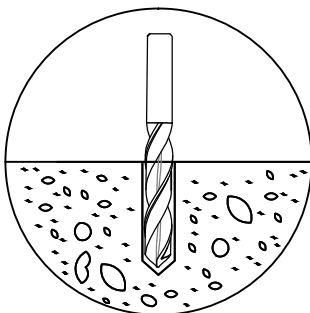



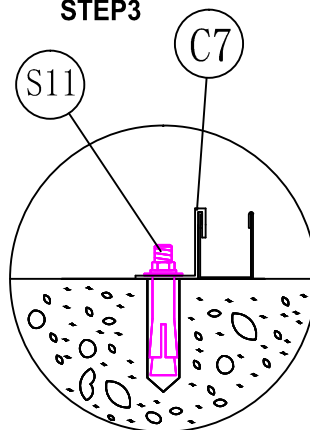

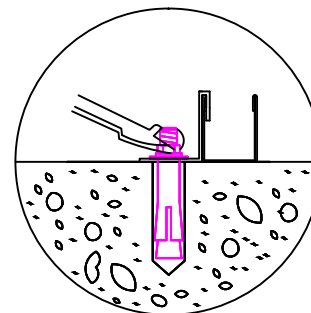

## STEP3



## STEP4



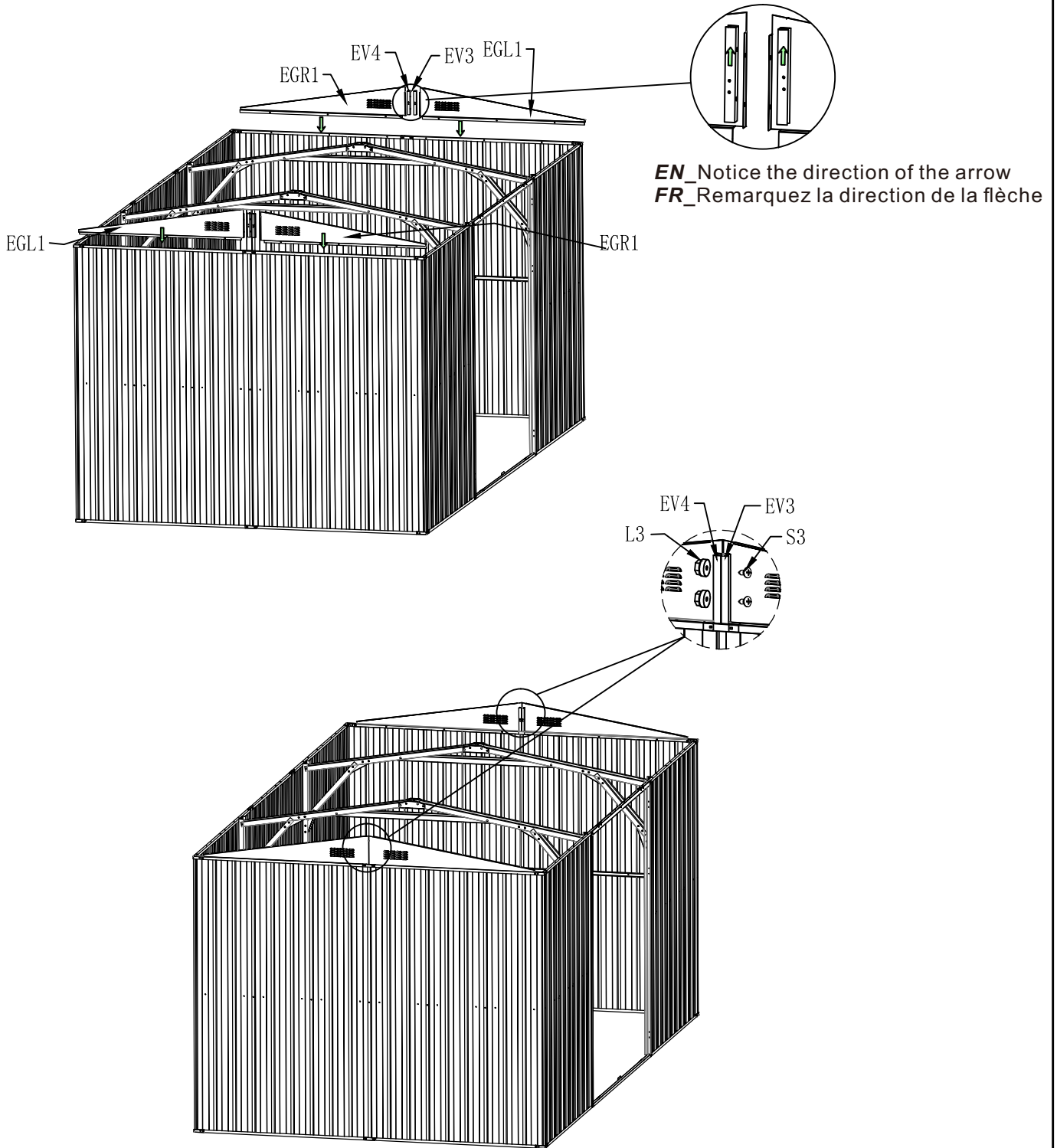

# Triangles Assembly

	EV4	2		EV3	2		EGL1	2		EGR1	2		L3	4
	S3	16												



# Roof Framing Assembly



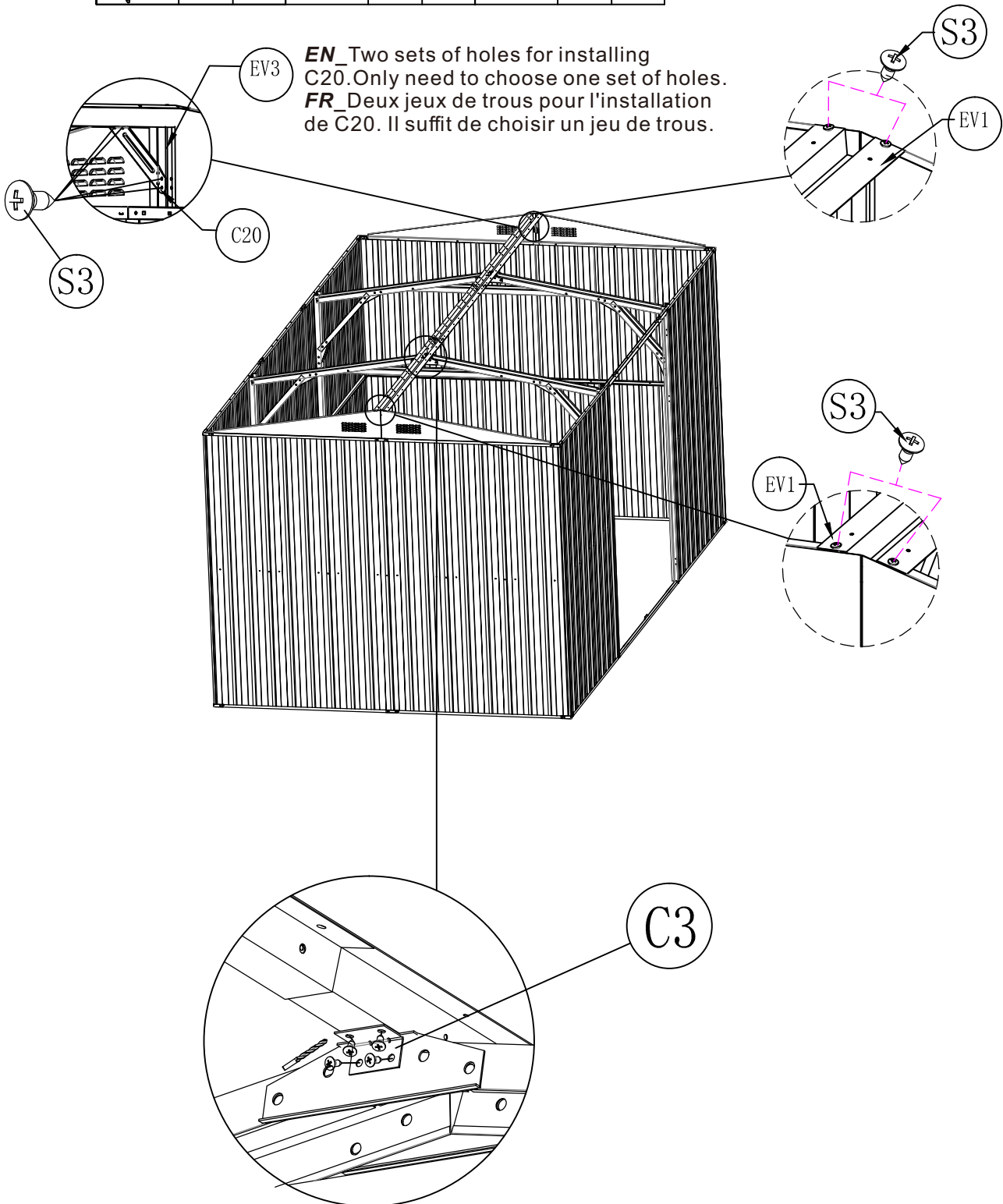

	C20	2		S3	28		C3	4
---	-----	---	---	----	----	---	----	---

**EN\_** Two sets of holes for installing C20. Only need to choose one set of holes.  
**FR\_** Deux jeux de trous pour l'installation de C20. Il suffit de choisir un jeu de trous.



# Roof Panels Assembly Step 1-2

## STEP 1

	EPT1	2		S3	4		S5	4		Waterproof tape
---	------	---	---	----	---	---	----	---	--	-----------------

**EN\_NOTE:** 1. Attach roof panel to top roof beam only using four (4) screws. Do not fasten to side wall angle at this time.

2. While installing roof panels use waterproof tape to seal roof ridge.

3. Waterproof tape should be applied in a continuous strip along the length of the roof.



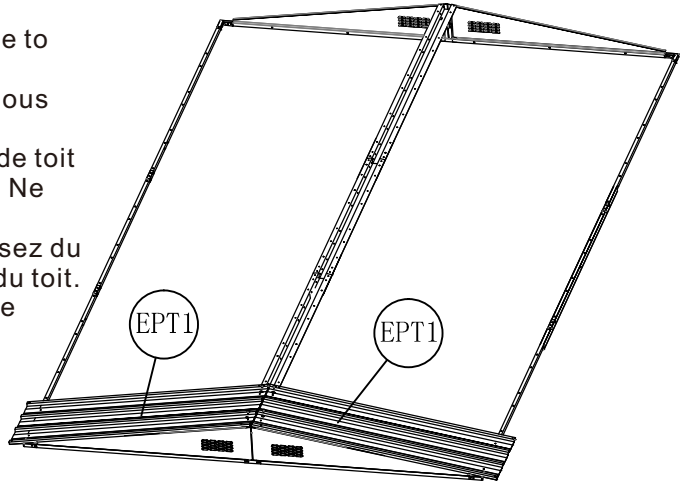
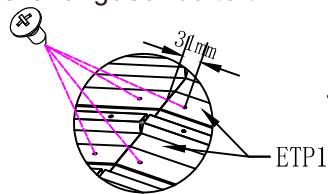

**FR\_NOTE:** 1 Fixer le panneau de toit à la poutre de toit supérieure uniquement à l'aide de quatre (4) vis. Ne pas fixer à l'angle du mur latéral pour le moment.

2. lors de l'installation des panneaux de toit, utilisez du ruban adhésif imperméable pour sceller le faîte du toit.

3. le ruban imperméable doit être appliqué en une bande continue sur toute la longueur du toit.



## STEP 2

	EPT1	2		S3	6		S5	6		ER1	2
	Waterproof tape										

**EN\_Continue** to apply waterproof tape.

**FR\_Poursuivre** l'application de la bande étanche.

### STEP 2

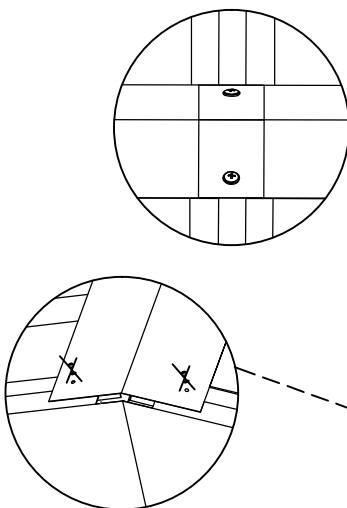

### STEP 1

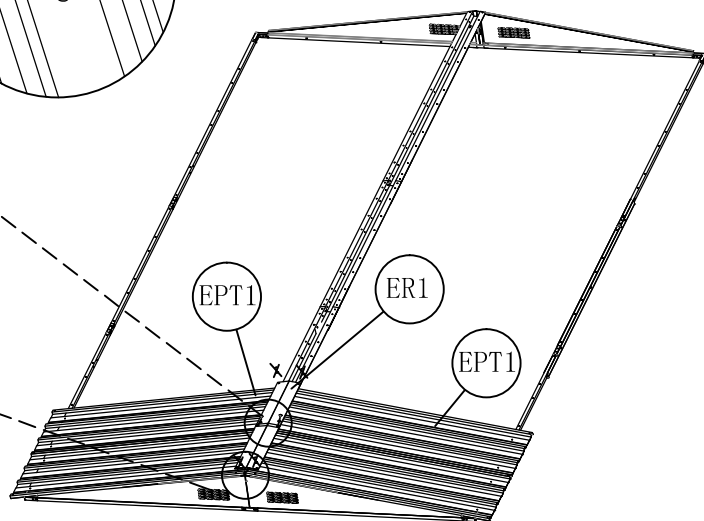
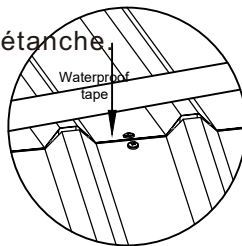





**EN\_Do not** secure end of ridge caps until caps are in place.

**FR\_Ne fixez pas** l'extrémité des faîtières avant qu'elles ne soient en place.

# Roof Panels Assembly Step 3-4



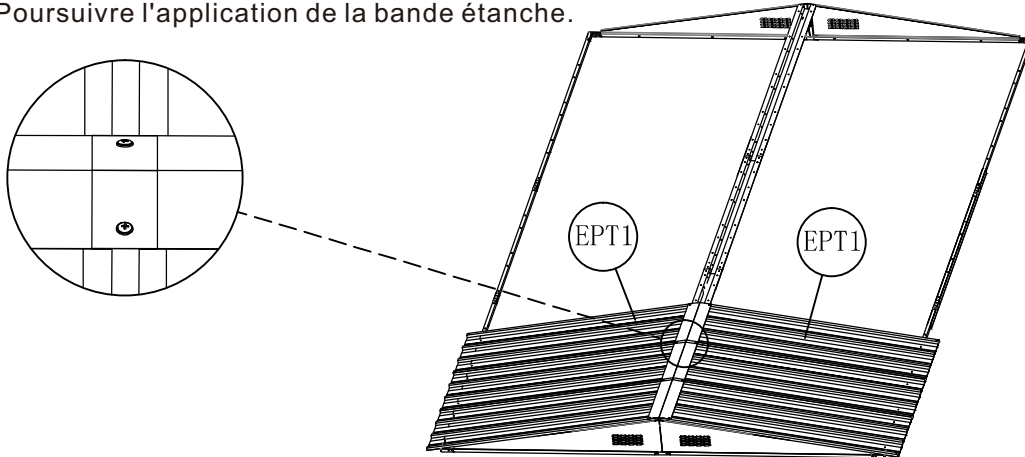

## STEP 3

	EPT1	2		S3	6		S5	6		ER1	1
	Waterproof tape										

**EN** Continue to apply waterproof tape.  
**FR** Poursuivre l'application de la bande étanche.



## STEP 4

	EPT1	16		S3	48		S5	48		ER1	8
	Waterproof tape										

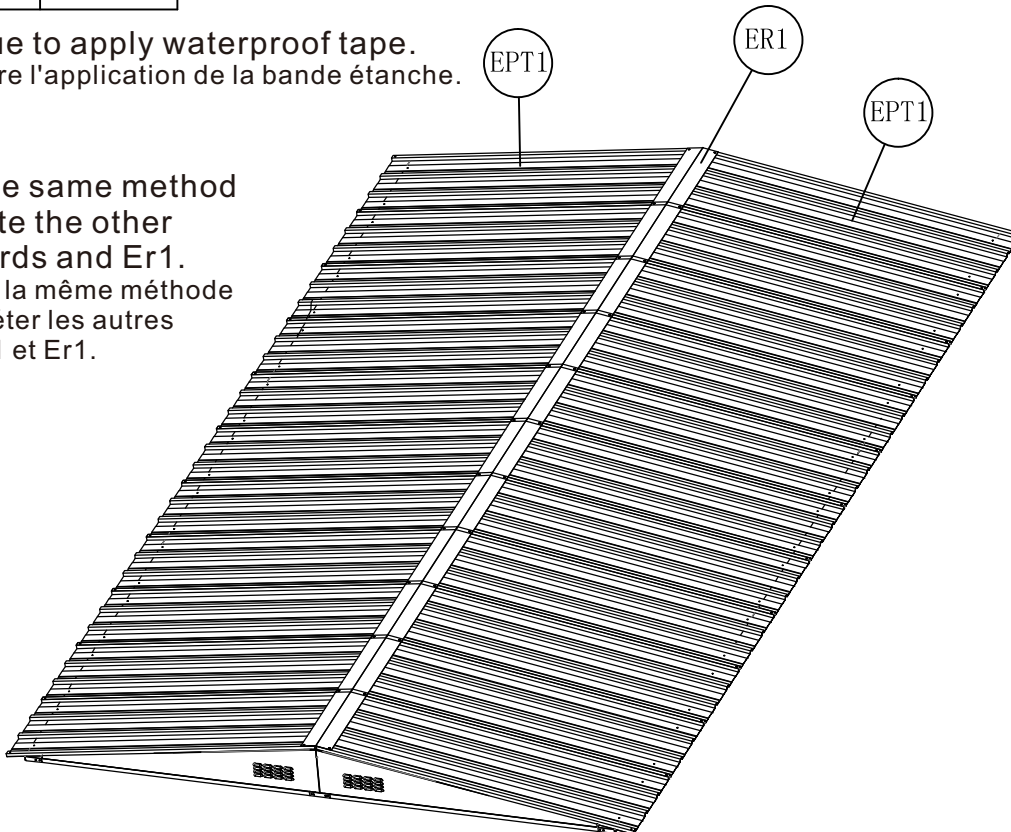

**EN** Continue to apply waterproof tape.  
**FR** Poursuivre l'application de la bande étanche.

**EN** Use the same method to complete the other EPT1 boards and Er1.  
**FR** Utilisez la même méthode pour compléter les autres cartes EPT1 et Er1.







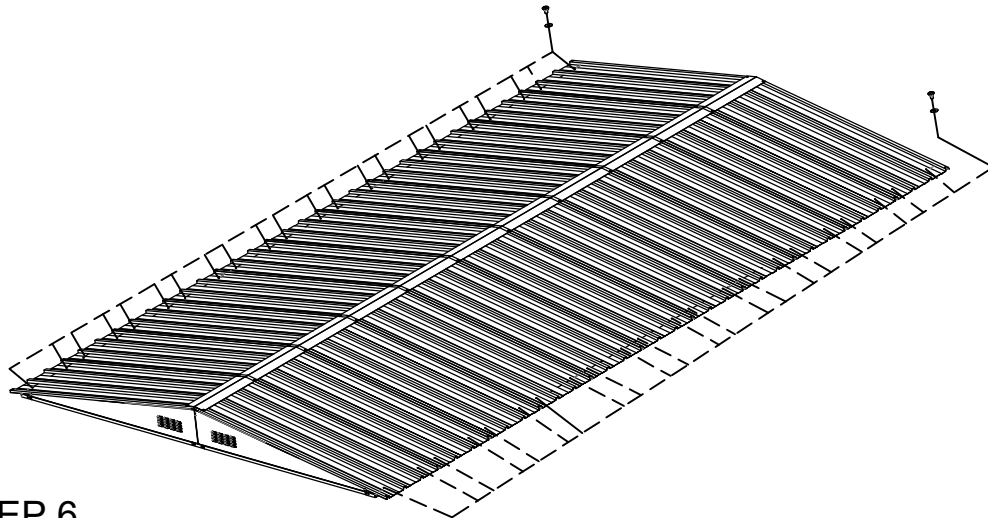

# Roof Panels Assembly Step 5-6

## STEP 5

	S3	44		S5	44
---	----	----	---	----	----



## STEP 6

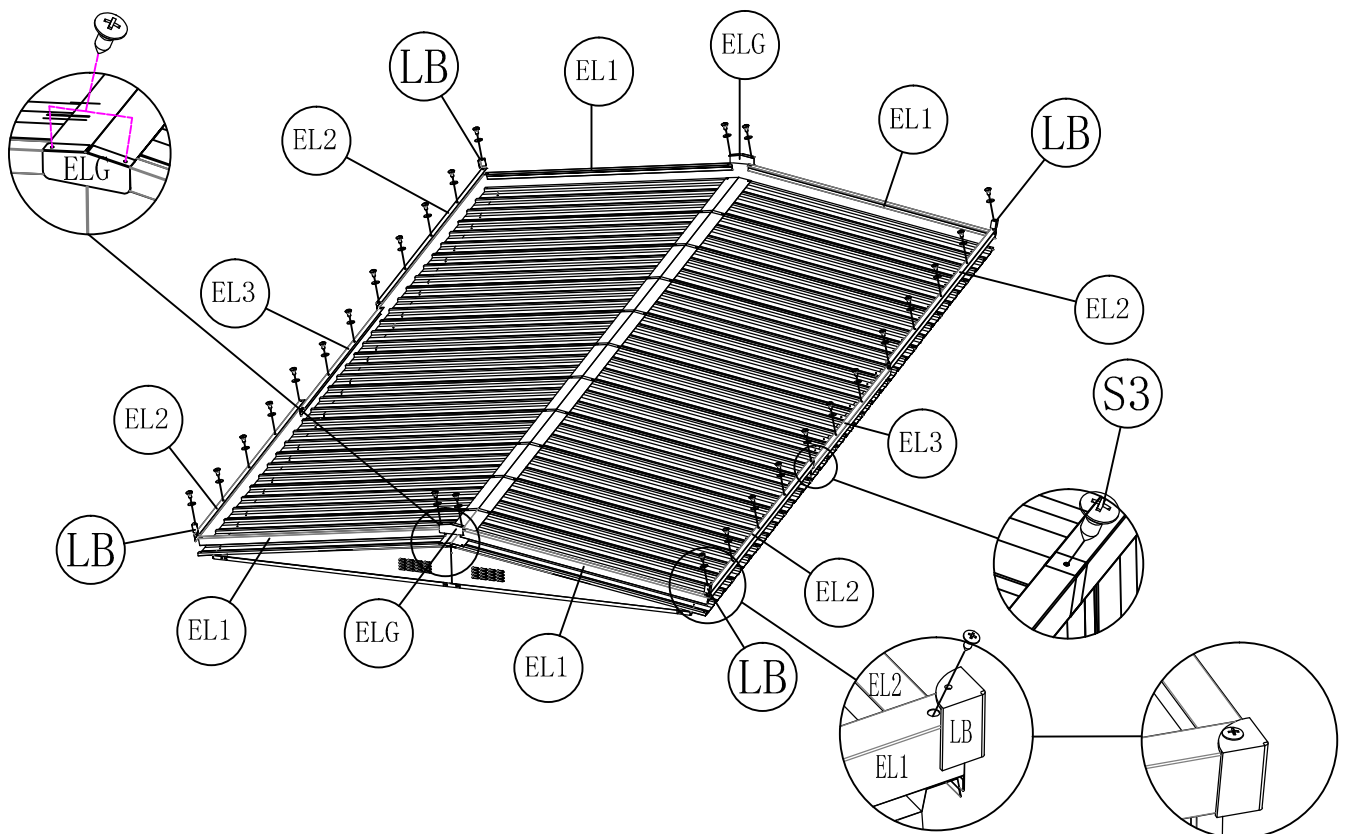

	EL1	4		EL2	4		ELG	2		LB	4
	EL3	2		S3	28		S5	28			

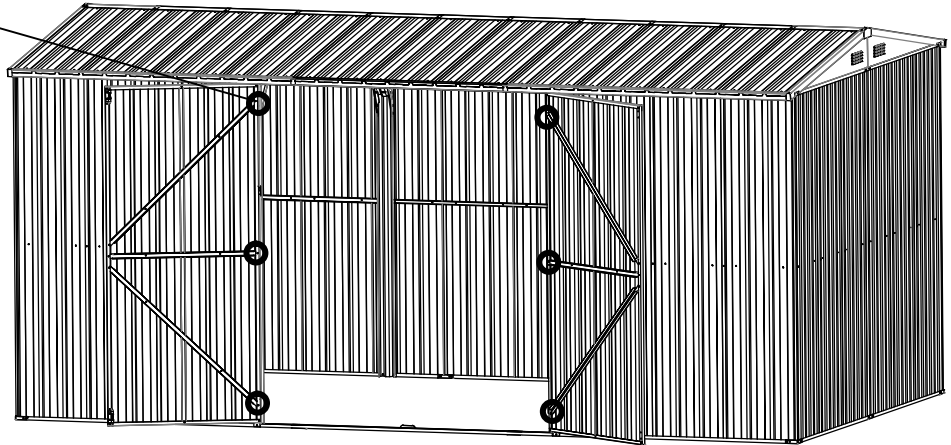
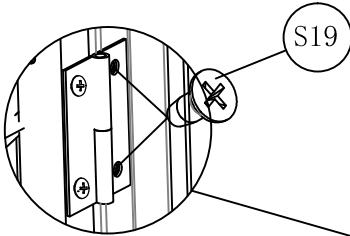

# Door Assembly

	S19	12
---	-----	----



	H1	1		S7	6
---	----	---	---	----	---

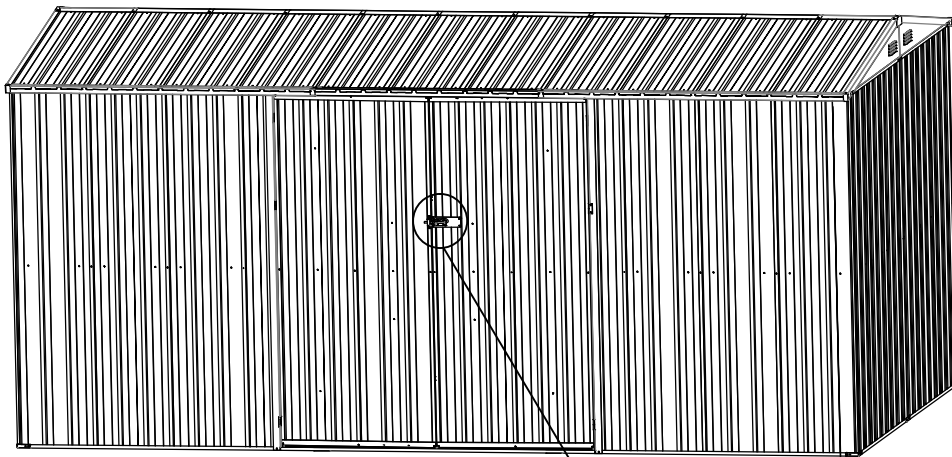

**EN** It is easy to use, please add some S5 under H1.  
**FR** Il est facile à utiliser, veuillez ajouter quelques S5 sous H1.

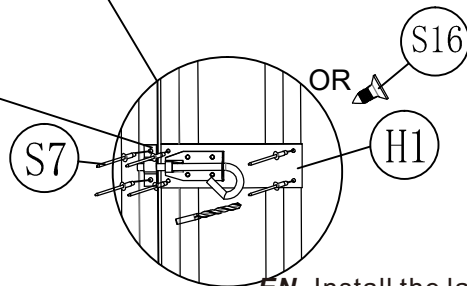
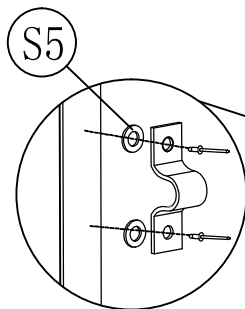

**EN** Install the latch in position as shown and fix with S16 or S7.  
**FR** Installer le loquet dans la position indiquée et le fixer avec S16 ou S7.

# PROTECTION

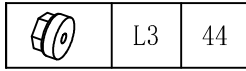

**EN**\_Use L3 screw protection cap to cover screws on the beam.

**FR**\_Utiliser le capuchon de protection de vis L3 pour couvrir les vis de la poutre.

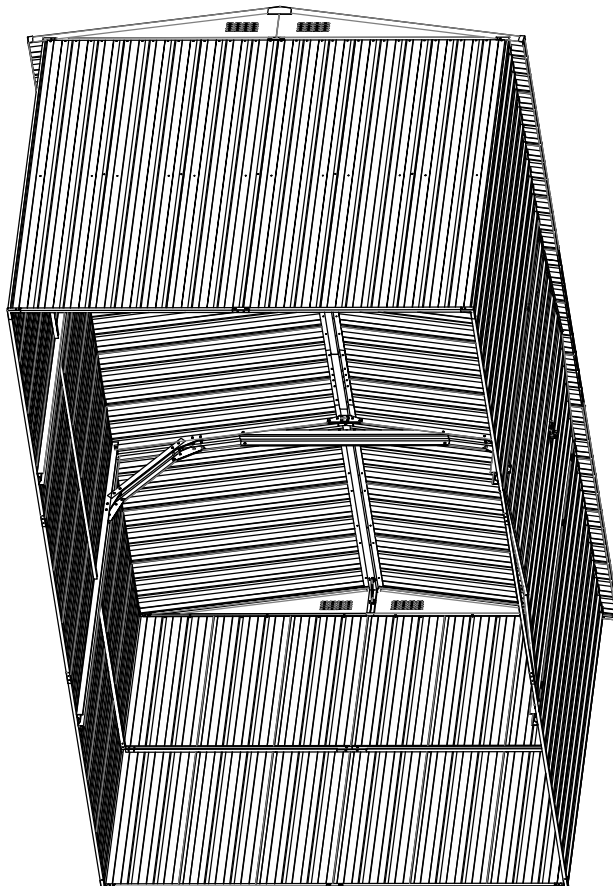
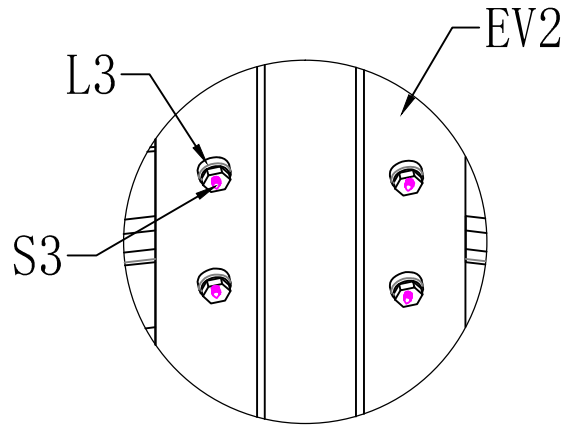



# Floor Frame Kit

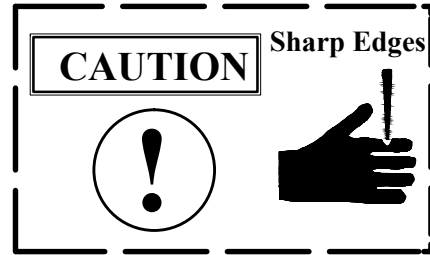
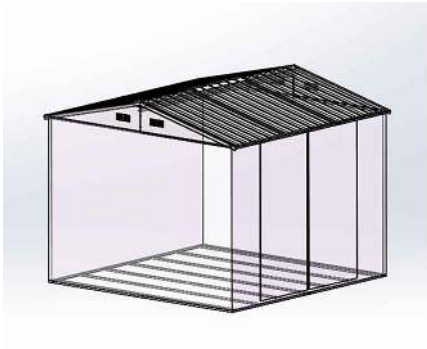

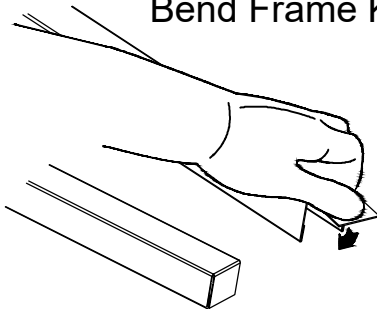

Bend Frame Kit

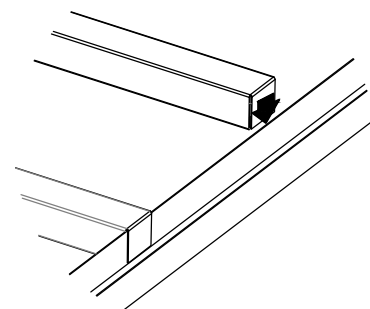

Assemble



	EF1	32		EJ1	16
		black			

**EN\_NOTE:** Adjust the spacing according to the number of floor frames, and the spacing ( L ) is between 250mm-300mm.

**FR\_REMARQUE :** Ajustez l'espacement en fonction du nombre de cadres de plancher, et l'espacement ( L ) est compris entre 250 mm et 300 mm.

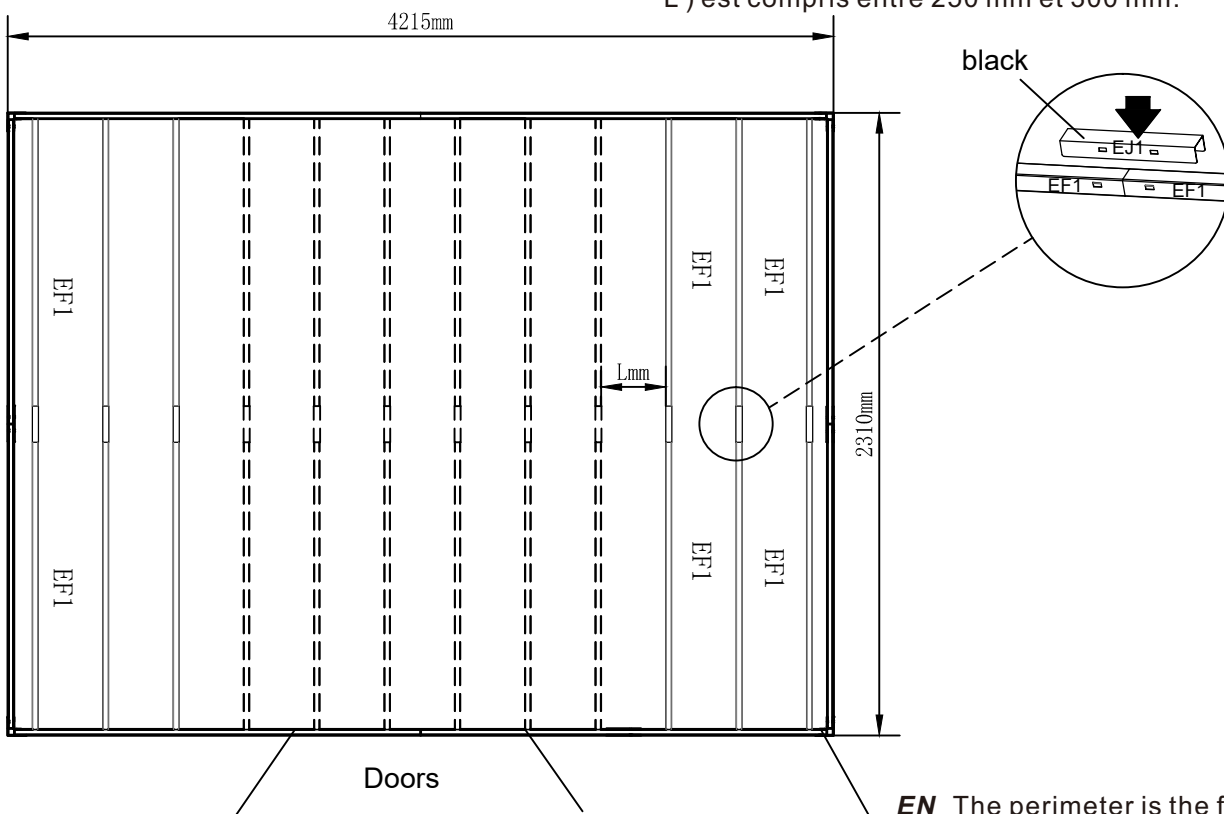

**EN\_** The perimeter is the floor frame from the building.

**FR\_** Le périmètre est le cadre du plancher du bâtiment.

If you have any questions, please contact our customer care center, Our contact details are below:

**US**

 001-877-644-9366

 customerservice@aosom.com

Imported by Aosom LLC  
27150 SW Kinsman Rd Wilsonville, OR 97070 USA  
MADE IN CHINA

Wenn Sie Fragen haben, wenden Sie sich bitte an unser Kundendienstzentrum, Unsere Kontaktdaten stehen unten:

**DE**

 0049-0(40)-88307530

 service@aosom.de

ADRESSE DES IMPORTEURE/Hersteller/REP:  
MH Handel GmbH  
Wendenstraße 309  
D-20537 Hamburg  
Germany  
IN CHINA HERGESTELLT

If you have any questions, please contact our customer care center, Our contact details are below:

**CA**

 416-792-6088

 customerservice@aosom.ca

Imported by Aosom Canada Inc.  
7270 Woodbine Avenue, Unit 307, Markham,  
Ontario Canada L3R 4B9  
MADE IN CHINA

Si vous avez la moindre question, veuillez contacter notre centre d'assistance à la clientèle, Nos coordonnées sont les suivantes:

 416-792-6088

 customerservice@aosom.ca

Importé par Aosom Canada Inc.  
7270 Woodbine Avenue, unité 307,  
Markham, Ontario Canada L3R 4B9  
FABRIQUÉ EN CHINE

In caso di dubbio, si prega di contattare il nostro centro assistenza clienti, I nostri dettagli di contatto sono di seguito:

**IT**

 0039-0249471447

 clienti@aosom.it

IMPORTATO DA/Produttore/REP:  
AOSOM Italy srl  
Centro Direzionale Milanofiori  
Strada 1 Palazzo F1  
20057 Assago (MI)  
P.I.: 08567220960  
FATTO IN CINA

Si tiene alguna pregunta, comuníquese con nuestro Centro de Atención al Cliente, Nuestros datos de contacto son los siguientes:

**ES**

 0034-931294512

 atencioncliente@aosom.es

IMPORTADOR/Fabricante/REP:  
SPANISH AOSOM, S.L.  
C/ROC GROS, N°15.08550, ELS HOSTALETES DE  
BALENYÀ, SPAIN.  
B66295775  
HECHO EN CHINA

If you have any questions, please contact our customer care center, Our contact details are below:

**UK**

 0044-800-240-4004

 enquiries@mhstar.co.uk

IMPORTER ADDRESS:  
MH STAR UK LTD  
Unit 27, Perivale Park,  
Horsenden lane South  
Perivale, UB6 7RH  
MADE IN CHINA

Se tiver alguma dúvida, por favor contacte o nosso Centro de Atendimento ao Cliente, Os nossos dados de contacto são os seguintes:

**PT**

 0034-931294512

 info@aosom.pt.

IMPORTADOR/Fabricante/REP:  
SPANISH AOSOM, S.L.  
C.ROC GROS N.15, 08550. ELS HOSTALETES DE  
BALENYÀ  
FEITO NA CHINA

Si vous avez la moindre question, veuillez contacter notre centre d'assistance à la clientèle, Nos coordonnées sont les suivantes:

**FR**

 0033-1-84166106

 aosom@mhfrance.fr

Importé par/Fabricant/REP:  
MH FRANCE  
2 Rue Maurice Hartmann  
92130 Issy Les Moulineaux  
France  
FABRIQUÉ EN CHINE



**FR**

**DONNEZ  
OU  
RECYCLEZ**



ASSOCIATION

OU



LIVRAISON

OU



DÉCHÈTERIE

Adresses sur [quefairedemesdechets.fr](http://quefairedemesdechets.fr)