

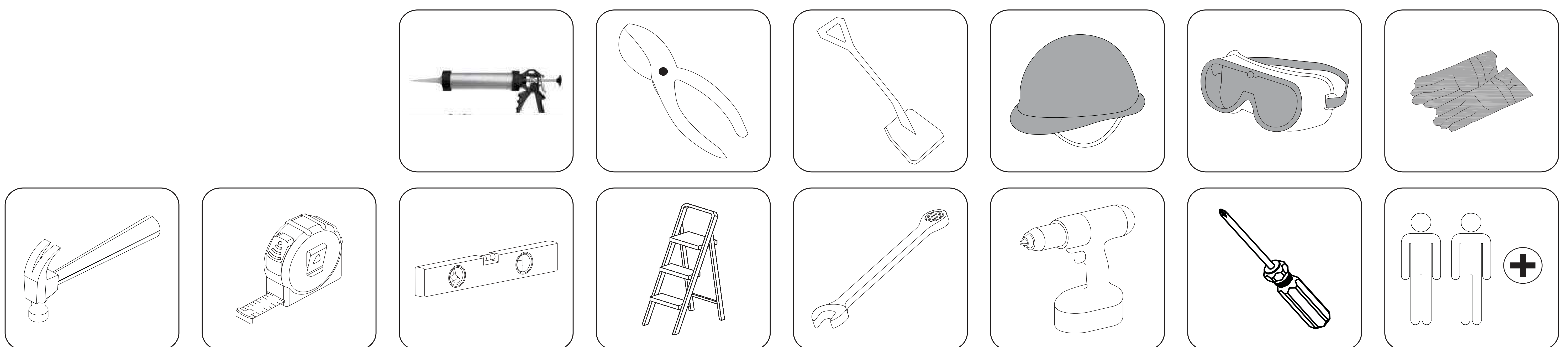

IN230900362V01_GL

845-334V02

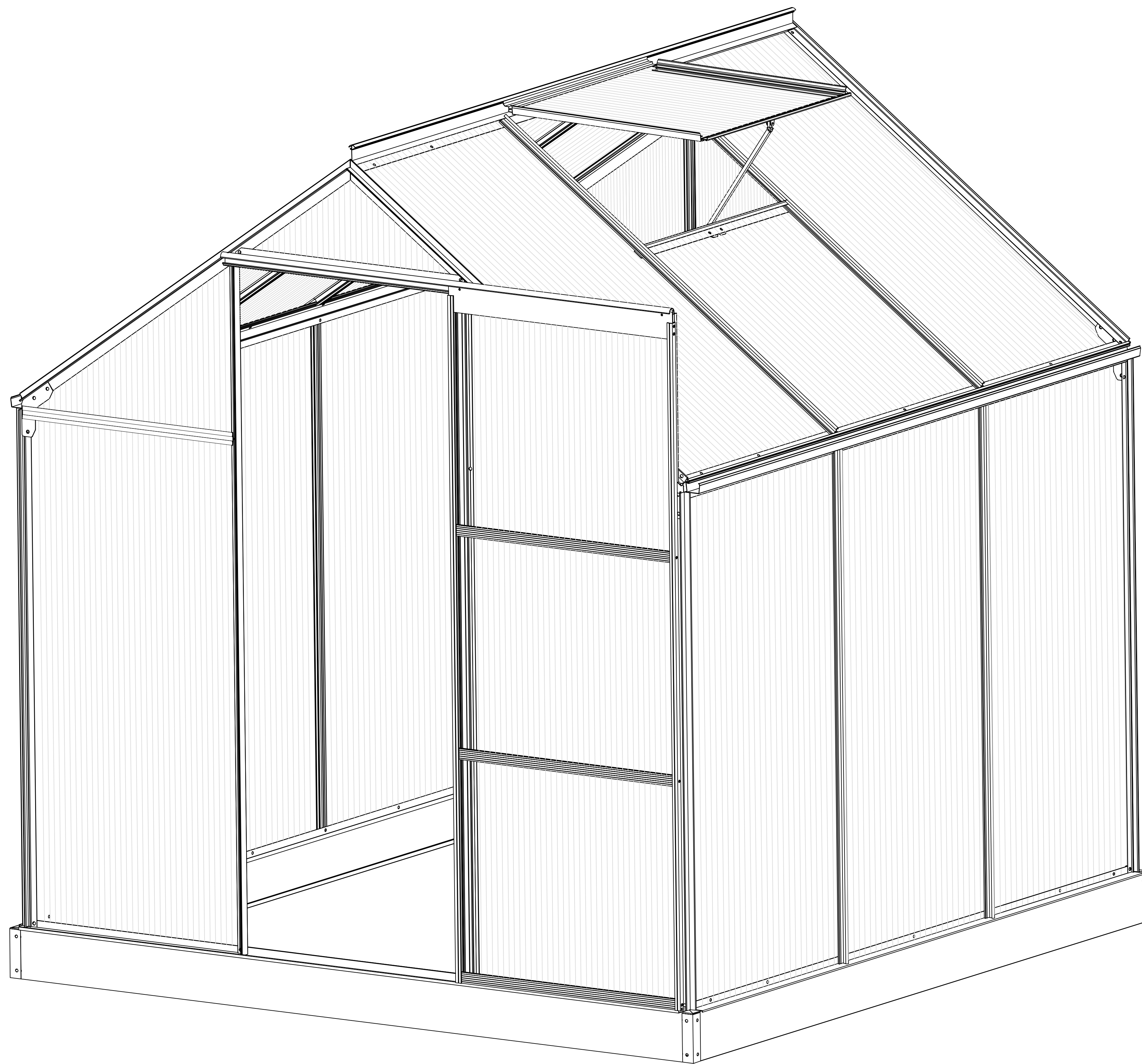

Tools Recommended

EN_IMPORTANT, RETAIN FOR FUTURE REFERENCE: READ CAREFULLY.

FR_IMPORTANT: A LIRE ATTENTIVEMENT ET À CONSERVER POUR CONSULTATION ULTÉRIEURE.

ES_IMPORTANTE, LEA Y GUARDE PARA FUTURAS REFERENCIAS.

PT_IMPORTANTE, RETER PARA REFERÊNCIA FUTURA: LEIA ATENTAMENTE.

DE_WICHTIG! SORGFÄLTIG LESEN UND FÜR SPÄTER NACHSCHLAGEN AUFBEWAHREN.

IT_IMPORTANTE! CONSERVARE IL PRESENTE MANUALE PER FUTURO RIFERIMENTO E LEGGERLO ATTENTAMENTE.

EN

Dear customer,

Thank you for purchasing this product. So that your appliance serves you well, please read all the instructions in this user's manual. If you have any questions, please contact our customer care center, Our contact details are below:

FR

Cher client,

Nous vous remercions d'avoir acheté ce produit. Afin que vous puissiez profiter pleinement de votre appareil, veuillez lire toutes les instructions de ce manuel d'utilisation. Si vous avez la moindre question, veuillez contacter notre centre d'assistance à la clientèle, Nos coordonnées sont les suivantes:

DE

Sehr geehrter Kunde,

Vielen Dank, dass Sie dieses Produkt erworben haben. Damit Ihr Gerät Ihnen gute Dienste leistet, lesen Sie bitte alle Hinweise in diesem Benutzerhandbuch. Wenn Sie Fragen haben, wenden Sie sich bitte an unser Kundendienstzentrum, Unsere Kontaktdaten stehen unten:

ES

Queridos clientes,

Gracias por comprar este producto. Para que su electrodoméstico le sirva mejor, lea todas las instrucciones de este manual del usuario. Si tiene alguna pregunta, comuníquese con nuestro Centro de Atención al Cliente, Nuestros datos de contacto son los siguientes:

PT

Caros clientes,

Obrigado por adquirir este produto. Para que o seu aparelho o sirva melhor, leia todas as instruções deste manual do utilizador. Se tiver alguma dúvida, por favor contacte o nosso Centro de Atendimento ao Cliente, Os nossos dados de contacto são os seguintes:

IT

Caro Cliente,







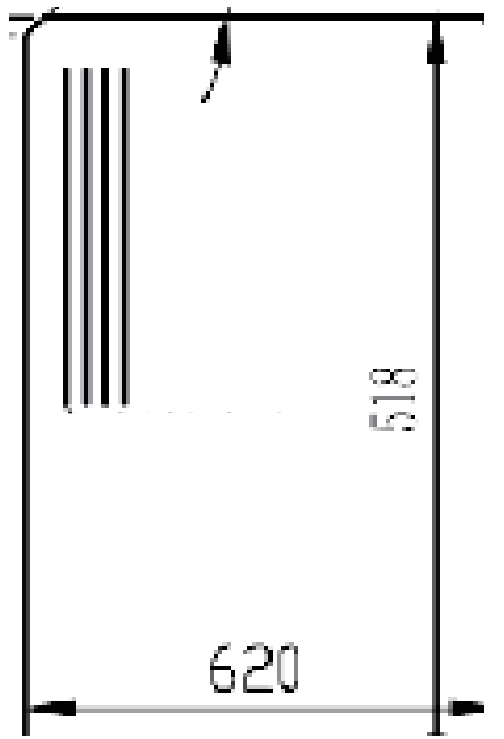
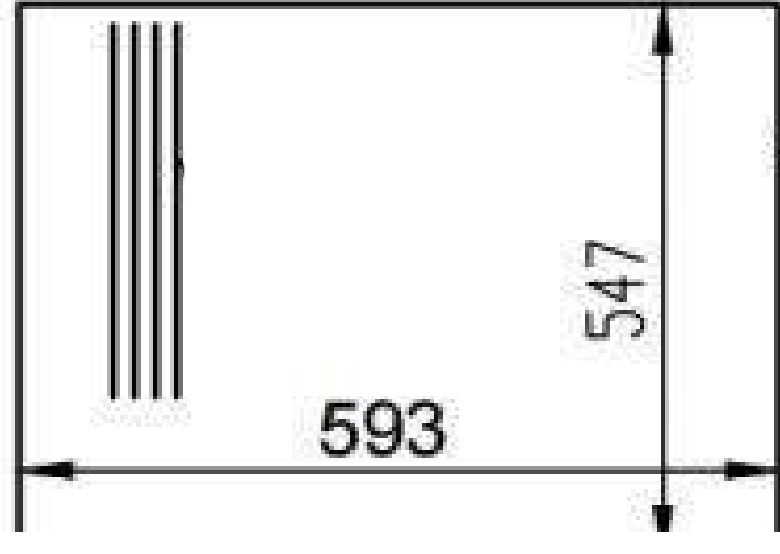
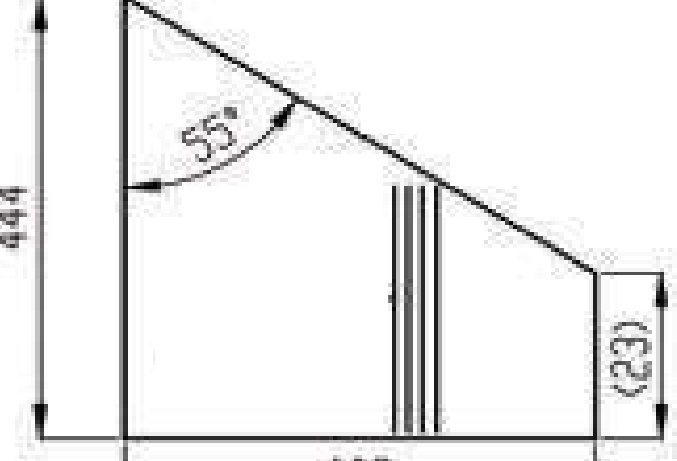
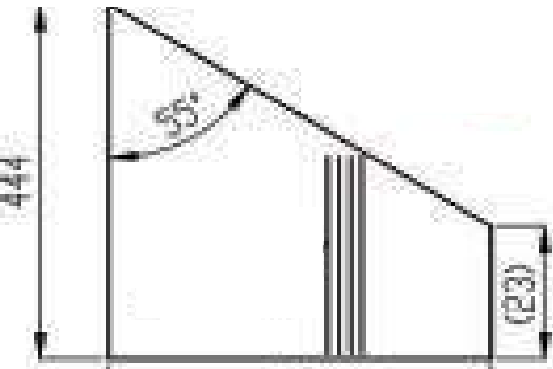
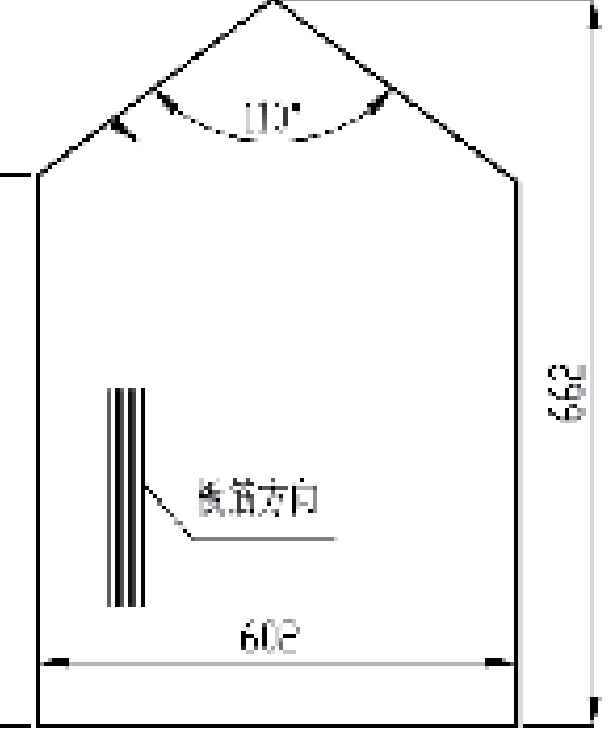
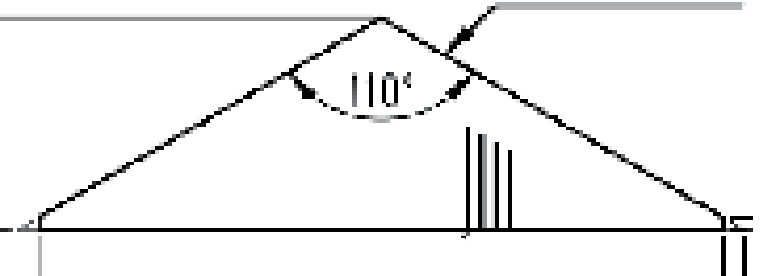
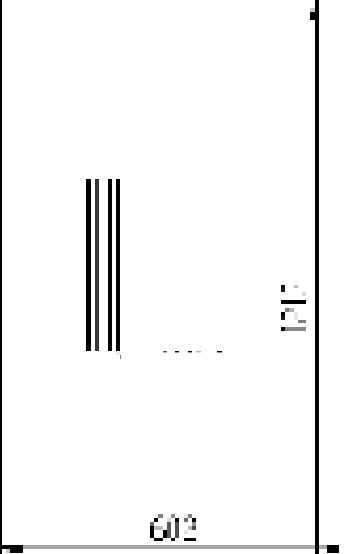
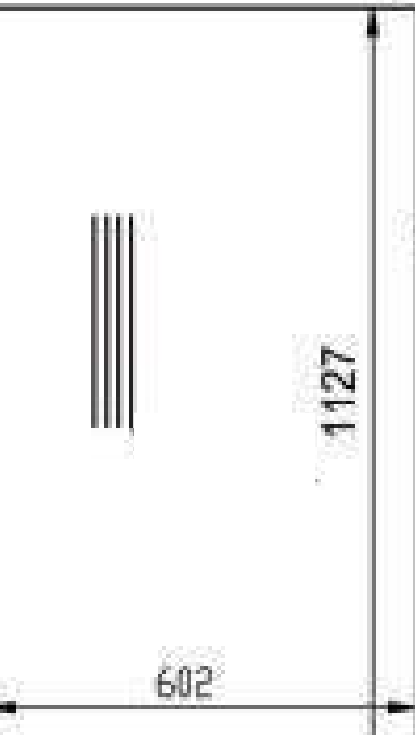
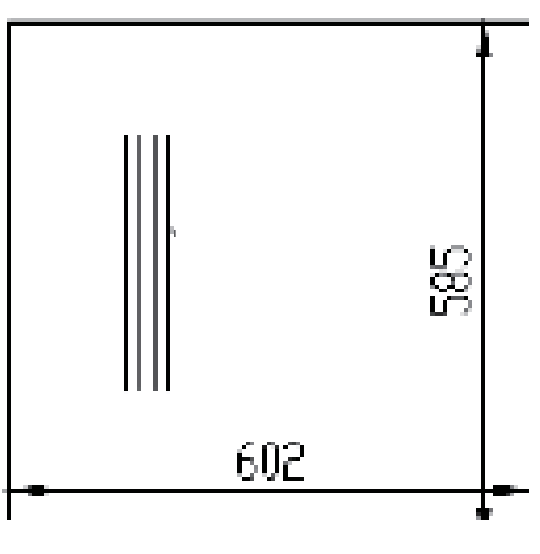



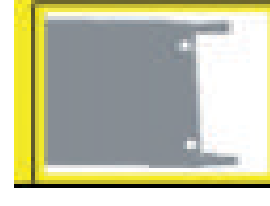
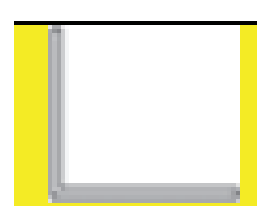
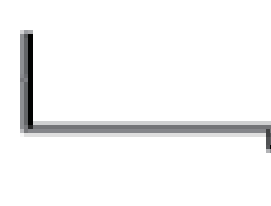
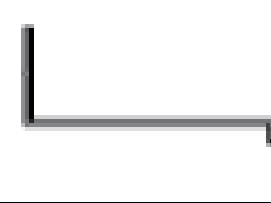
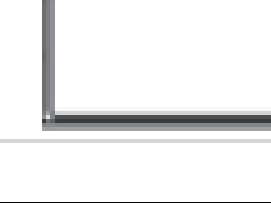
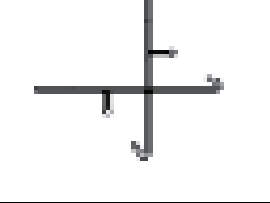
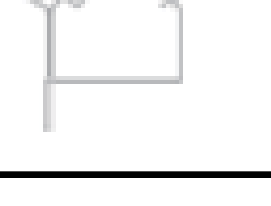
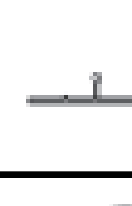
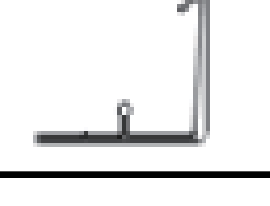
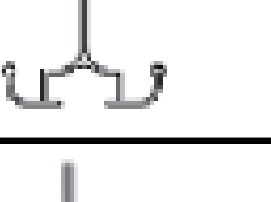
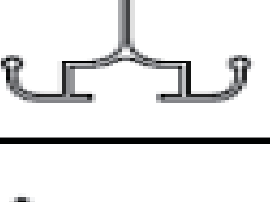
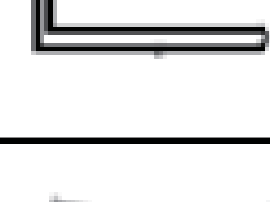
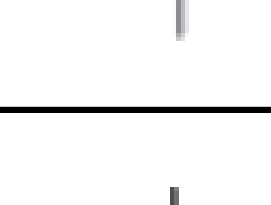
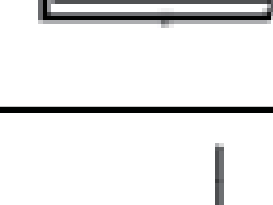
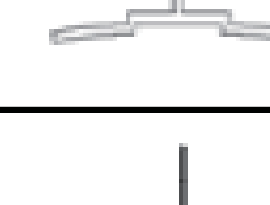
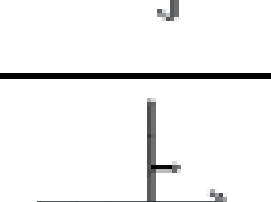
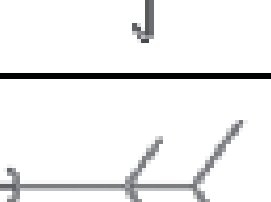
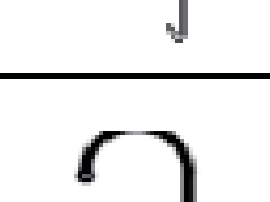
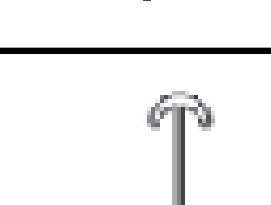
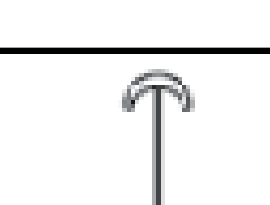
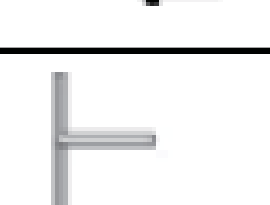
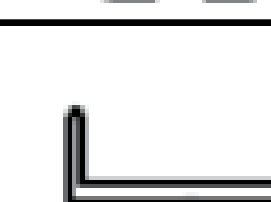
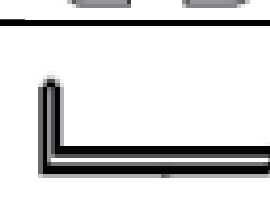
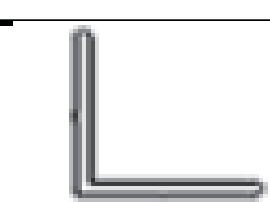
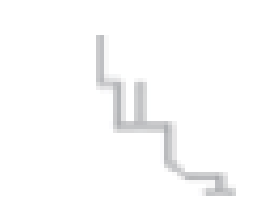

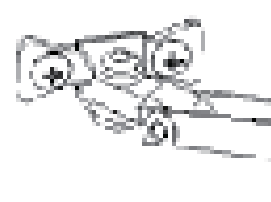
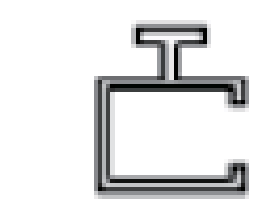
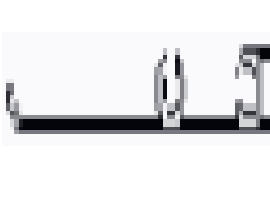

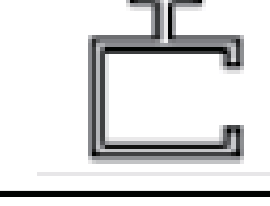
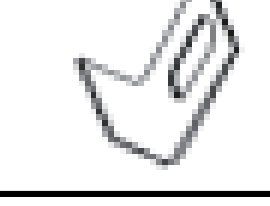
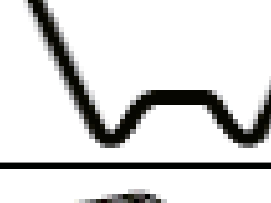
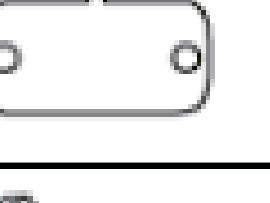
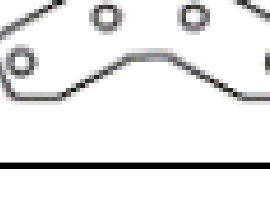
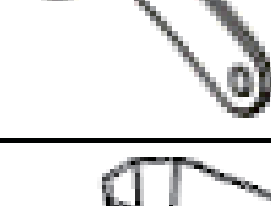
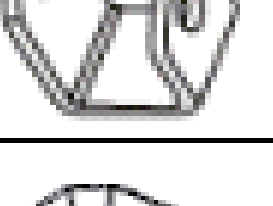
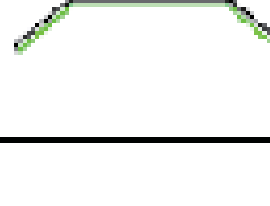

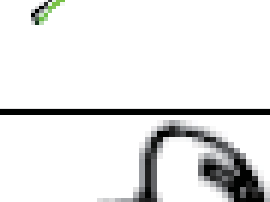

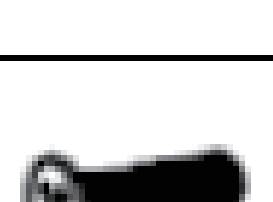

Grazie per aver acquistato questo prodotto. Per servirti meglio con questo apparecchio ti prego di leggere tutte le istruzioni in presente manuale utente. In caso di dubbio, si prega di contattare il nostro centro assistenza clienti, I nostri dettagli di contatto sono di seguito:

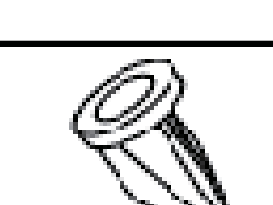
Country	 Phone	 Email
US	001-877-644-9366	customerservice@aosom.com
CA	416-792-6088	customerservice@aosom.ca
UK	0044-800-240-4004	enquiries@mhstar.co.uk
DE	0049-0(40)-88307530	service@aosom.de
FR	0033-1-84166106	aosom@mhfrance.fr
ES	0034-931294512	atencioncliente@aosom.es
PT	0034-931294512	info@aosom.pt
IT	0039-0249471447	clienti@aosom.it

SF190 CARTON : 1/2

PART	NO.	SIZE(mm)	QTY	PART	NO.	SIZE(mm)	QTY
	P1	518x620	3		P2	547x593	1
	P4L	602X444	2		P4R	602X444	2
	P6	662X602	1		P7	623X234	1
	P8	1213x602	11		P9	1127x602	5
	P10	585x602	1				

SF190 CARTON : 2/2

PART	NO.	SIZE (mm)	QTY	PART	NO.	SIZE (mm)	QTY	PART	NO.	SIZE (mm)	QTY
	1	1893	4		3	345	4		4	1830	2
	5	1830	1		6	1830	1		7	1215	4
	8	1830	2		9L	1641	1		9R	1641	1
	10L	1664	1		10R	1664	1		12	596	2
	13	635	1		14	1824	1		15	602	5
	16-1	1130	1		16-2	1130	1		16-3	1130	1
	16-4	1130	1		17	1830	1		18	1245	1
	19	1215	4		20	1113	4		21	632	1
	22	1362	4		23	1310	2		25	396	1
	W1	590	1		W2	522	2		W3	590	1
	W4	380	1		D1	1614	1		D2	621	1
	D3	621	3		D4	1614	1		B2		16
	B3		140		B4		1		B5		4
	B6		1		B8		1		T1	240	4
	S3L		2		S3R		2		T2	240	2
	S8		1		S9		1		F1	ST3. 6X10	10
	F2	M5X20	2		F3	M5X35	2		F4	M6X10	106
	F5	M5X10	3		F8	M4X15	1		F9	M4X22	1
	F11	T5X15	4		S2		100		S3		100
	F10	ST4. 2X13	100						MANUAL		1

EN

TO PREVENT INJURY, READ AND UNDERSTAND THE GREENHOUSE ASSEMBLY INSTRUCTIONS BEFORE USE.

GENERAL SAFETY, WARNINGS AND PRECAUTIONS

KEEP WORK AREA CLEAN AND DRY.

Cluttered, damp or wet work areas invite injuries.

STAY ALERT. Watch what you are doing at all times. Use common sense. Do not use the greenhouse when you are tired or distracted from the job at hand. It is recommended to use gloves for assembling the greenhouse.

MAINTAIN THIS PRODUCT WITH CARE.

Keep the greenhouse clean and dry for better performance: maintenance should be performed regularly.

USE THE RIGHT PRODUCT FOR THE JOB.

Do not attempt to force a small product to do the work of a larger industrial product. There are certain applications for which the greenhouse was designed. It will do the job better and more safely in the manner for which it was intended. Do not modify the greenhouse and do not use the greenhouse for a purpose for which it was not intended.

MAINTAIN A SAFE WORKING ENVIRONMENT.

Keep the work area tidy. Make sure there is adequate surrounding workspace. Avoid high traffic areas. Always keep the work area free of obstructions, grease, oil, trash and other debris.

PROPER GREENHOUSE LOCATION.

Make sure the greenhouse is located on a flat level surface.

FR

POUR ÉVITER LES RISQUES DE BLESSURES, VEILLENZ LIRE ET COMPRENDRE LES INSTRUCTIONS DE MONTAGE DE LA SERRE AVANT DE L'UTILISER.

SÉCURITÉ GÉNÉRALE, AVERTISSEMENTS ET PRÉCAUTIONS

GARDER LA ZONE DE TRAVAIL PROPRE ET SÈCHE.

Les zones de travail encombrées, humides ou mouillées sont propices aux blessures. **RESTEZ VIGILANT.** Surveillez ce que vous faites à tout moment. Faites preuve de bon sens. N'utilisez pas la serre lorsque vous êtes fatigué ou distrait du travail en cours. Il est recommandé d'utiliser des gants pour le montage de la serre.

ENTRENEZ CE PRODUIT AVEC SOIN.

Gardez la serre propre et sèche pour un meilleur rendement : l'entretien doit être effectué régulièrement.

UTILISEZ LE PRODUIT APPROPRIÉ POUR LE TRAVAIL À EFFECTUER.

N'essayez pas de forcer un petit produit à faire le travail d'un produit industriel plus important. La serre a été conçue pour certaines applications. Elle fera mieux le travail pour lequel elle a été conçue et de manière plus sûre. Ne modifiez pas la serre et n'utilisez pas la serre à des fins pour lesquelles elle n'a pas été conçue.

MAINTENIR UN ENVIRONNEMENT DE TRAVAIL SÛR.

Maintenez l'espace de travail en ordre. Assurez-vous que l'espace de travail environnant est adéquat. Évitez les zones à forte circulation. Maintenez la zone de travail toujours libre de tout obstacle, graisse, huile, déchets et autres débris.

EMPLACEMENT ADÉQUAT DE LA SERRE.

Veillez à ce que la serre soit située sur une surface plane et de niveau.

ES

PARA PREVENIR LESIONES, LEA Y COMPRENDA LAS INSTRUCCIONES DE MONTAJE DEL INVERNADERO ANTES DE USARLO.

SEGURIDAD GENERAL, ADVERTENCIAS Y PRECAUCIONES

MANTENGA EL ÁREA DE TRABAJO LIMPIA Y SECA.

Las áreas de trabajo desordenadas, húmedas o mojadas pueden provocar lesiones. **MANTÉNGASE ALERTA.** Vigile lo que está haciendo en todo momento con el conocimiento común. No use el invernadero cuando esté cansado o distraído del trabajo en cuestión. Se recomienda utilizar guantes para montar el invernadero.

MANTENGA ESTE PRODUCTO CON CUIDADO.

Mantenga el invernadero limpio y seco para un mejor rendimiento: el mantenimiento debe realizarse con regularidad.

USE EL PRODUCTO ADECUADO PARA EL TRABAJO.

No intente forzar a un producto pequeño a hacer el trabajo que debe hacerse por un producto industrial más grande. Existen determinadas aplicaciones para las que se ha diseñado el invernadero. Puede hacer el trabajo mejor y con más seguridad si se usa en la manera para la que fue diseñado. No modifique el invernadero y no lo utilice para fines para los que no fue diseñado.

MANTENGA UN AMBIENTE DE TRABAJO SEGURO.

Mantenga el área de trabajo ordenada. Asegúrese de que haya un espacio de trabajo circundante adecuado. No lo use en las áreas de mucho tráfico. Mantenga siempre el área de trabajo libre de obstrucciones, grasa, aceite, basura y otros desechos.

UBICACIÓN APROPIADA DEL INVERNADERO.

Asegúrese de que el invernadero esté ubicado en una superficie plana y nivelada.

PT

SEGURANÇA GERAL, AVISOS E PRECAUÇÕES

MANTER A ÁREA DE TRABALHO LIMPA E SECA.

As áreas de trabalho desorganizadas, húmidas ou molhadas provocam lesões. **ATENÇÃO:** Esteja sempre atento ao que está a fazer. Use comum sentido. Não utilizar a estufa quando estiver esgotado ou distraído do trabalho em questão. Recomenda-se o uso de luvas para montar a estufa.

MANTENHA ESTE PRODUTO COM PRUDÊNCIA.

Mantenha a estufa limpa e seca para um melhor desempenho: a manutenção deve ser feita regularmente.

UTILIZAR O PRODUTO CERTO PARA O FUNCIONAMENTO.

Não tentar forçar um produto pequeno a fazer o funcionamento de um produto industrial maior. Existem certas aplicações para as quais o estufa foi concebida. Fará o trabalho de forma melhor e mais segura da forma a que foi concebido. Não modificar a estufa e não utilizar a estufa para um fim para o qual não foi concebida.

MANTER UM AMBIENTE DE TRABALHO SEGURO.

Manter a área de trabalho arrumada. Certificar-se de que existe um ambiente de trabalho adequado espaço o suficiente. Manter sempre a área de trabalho livre de obstruções, gorduras, óleo, lixo e outros detritos.

LOCALIZAÇÃO ADEQUADA DA ESTUFA.

Certifique-se de que a estufa está localizada numa superfície de nivelada.

DE

Um Verletzungen zu vermeiden, lesen und verstehen Sie bitte vor dem Gebrauch die Anweisungen zur Montage des Gewächshauses.

Allgemeine Sicherheit, Warnhinweise und Vorsichtsmaßnahmen

Halten Sie Arbeitsbereich sauber und trocken .

Überfüllte, feuchte oder nasse Arbeitsbereiche können zu Verletzungen führen. WACHSAM BLEIBEN. Beobachten Sie jederzeit, was Sie tun. Verwenden Sie gesunden Menschenverstand. Verwenden Sie das Gewächshaus nicht, wenn Sie müde oder von der anstehenden Aufgabe abgelenkt sind. Es wird empfohlen, für die Montage des Gewächshauses Handschuhe zu tragen.

Behalten Sie dieses Produkt mit Pflege

Halten Sie das Gewächshaus sauber und trocken, um eine bessere Leistung zu erzielen: Regelmäßige Wartungsarbeiten sollten durchgeführt werden.

Verwenden Sie das richtige Produkt für den Job

Versuchen Sie nicht, ein kleines Produkt zu zwingen, die Arbeit eines größeren Industrieprodukts zu erledigen. Es gibt bestimmte Anwendungen, für die das Gewächshaus konzipiert wurde. Es wird die Arbeit besser und sicherer in der Weise erledigen, für die es bestimmt war. Ändern Sie das Gewächshaus nicht und verwenden Sie es nicht für Zwecke, für die es nicht vorgesehen war.

Sorgen Sie für ein sicheres Arbeitsumfeld.

Halten Sie den Arbeitsbereich sauber und ordentlich. Stellen Sie sicher, dass Sie genügend Arbeitsfläche um sich haben. Vermeiden Sie stark frequentierte Bereiche. Halten Sie den Arbeitsbereich immer frei von Hindernissen, Fett, Öl, Müll und anderen Fremdkörpern.

Richtige Gewächshauslage.

Stellen Sie sicher, dass sich das Gewächshaus auf einer ebenen Fläche befindet.

IT

PER PREVENIRE LESIONI, LEGGETE E COMPRENDETE LE ISTRUZIONI DI ASSEMBLAGGIO DELLA SERRA PRIMA DELL'USO.

SICUREZZA GENERALE, AVVERTENZE E PRECAUZIONI

MANTENETE L'AREA DI LAVORO PULITA E ASCIUTTA.

Le aree di lavoro disordinate, umide o bagnate potrebbero provocare lesioni. STAI ATTENTO. Stai attento su cosa stai facendo in ogni momento. Usa il senso comune e non usare la serra quando sei stanco o distratto nel lavoro da svolgere. Si consiglia di utilizzare i guanti per l'assemblaggio della serra.

MANTENETE QUESTO PRODOTTO CON CURA.

Mantieni la serra pulita e asciutta per prestazioni migliori: la manutenzione deve essere eseguita regolarmente.

UTILIZZATE IL PRODOTTO GIUSTO PER IL LAVORO.

Non tentare di forzare un prodotto piccolo a svolgere un lavoro di un prodotto industriale più grande. Ci sono alcune applicazioni per le quali il prodotto è stato progettato. Il prodotto funzionerà meglio e più sicuro nel modo per cui è stato progettato. Non modificare la serra e non utilizzare la serra per scopi per i quali non è stata concepita.

MANTENETE UN AMBIENTE DI LAVORO SICURO.

Tieni in ordine l'area di lavoro. Assicurati che ci sia uno spazio di lavoro circostante adeguato. Evita le zone di molto traffico. Mantieni sempre l'area di lavoro libera da ostruzioni, grasso, olio, rifiuti e altri detriti.

POSIZIONE ADEGUATA DELLA SERRA.

Assicurati che la serra si trovi su una superficie piana e livellata.

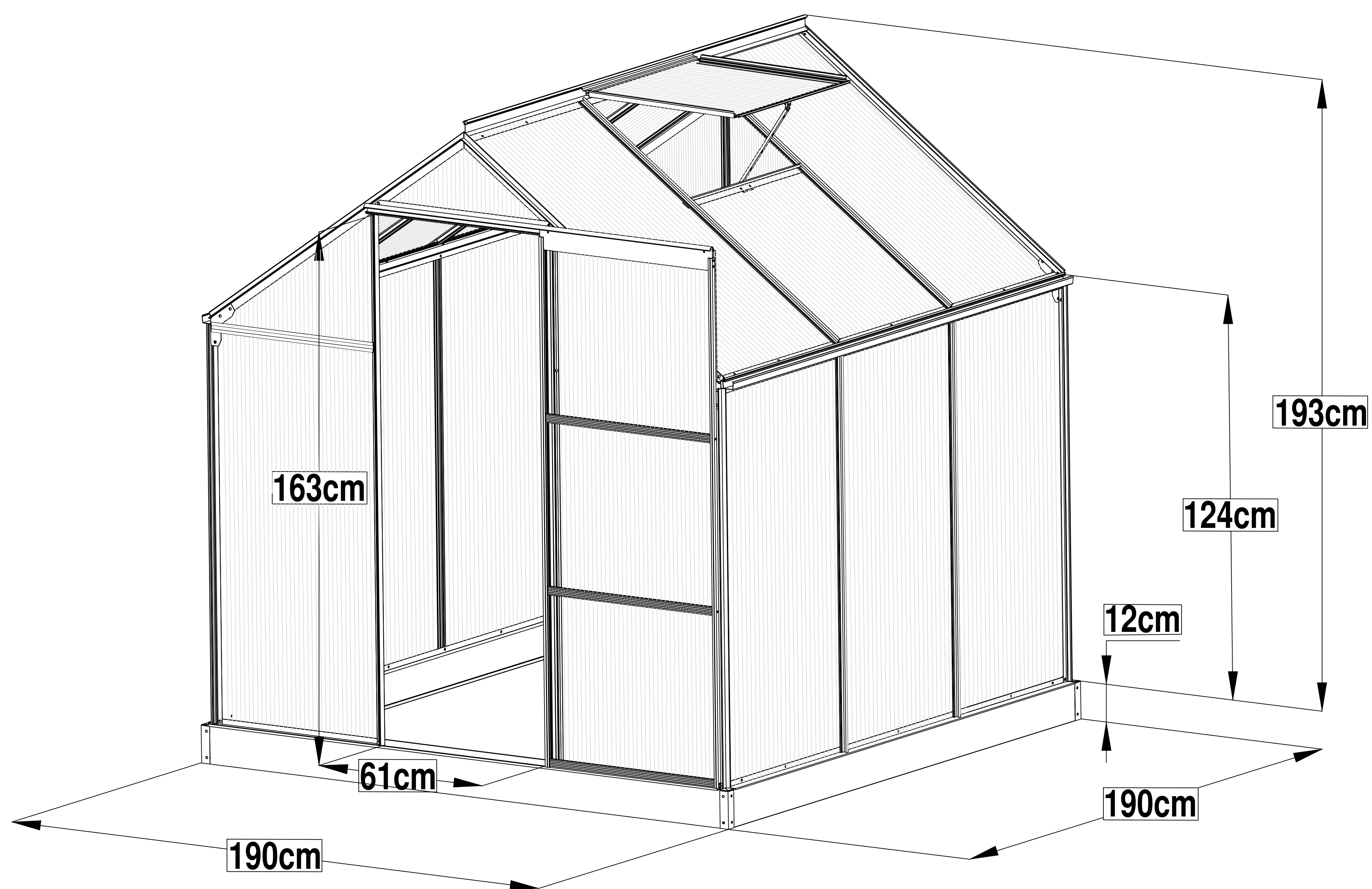

SF190



EN If you meet some difficult during the assembly, please loosen the relevant screws for adjustment first, and then tighten the screws again.

FR Si vous rencontrez des difficultés lors du montage, veuillez d'abord desserrer les vis correspondantes pour les ajustements, puis les resserrer.

ES Si encuentra alguna dificultad durante el montaje, primero afloje los tornillos correspondientes para ajustar, y luego vuelva a apretarlos.

PT Se encontrar alguma dificuldade durante a montagem, por favor solte os parafusos relevantes para ajuste primeiro, e depois aperte novamente os parafusos.

DE Wenn Sie während der Montage auf Schwierigkeiten stoßen, lösen Sie bitte zuerst die entsprechenden Schrauben zur Einstellung und ziehen Sie die Schrauben dann wieder fest.



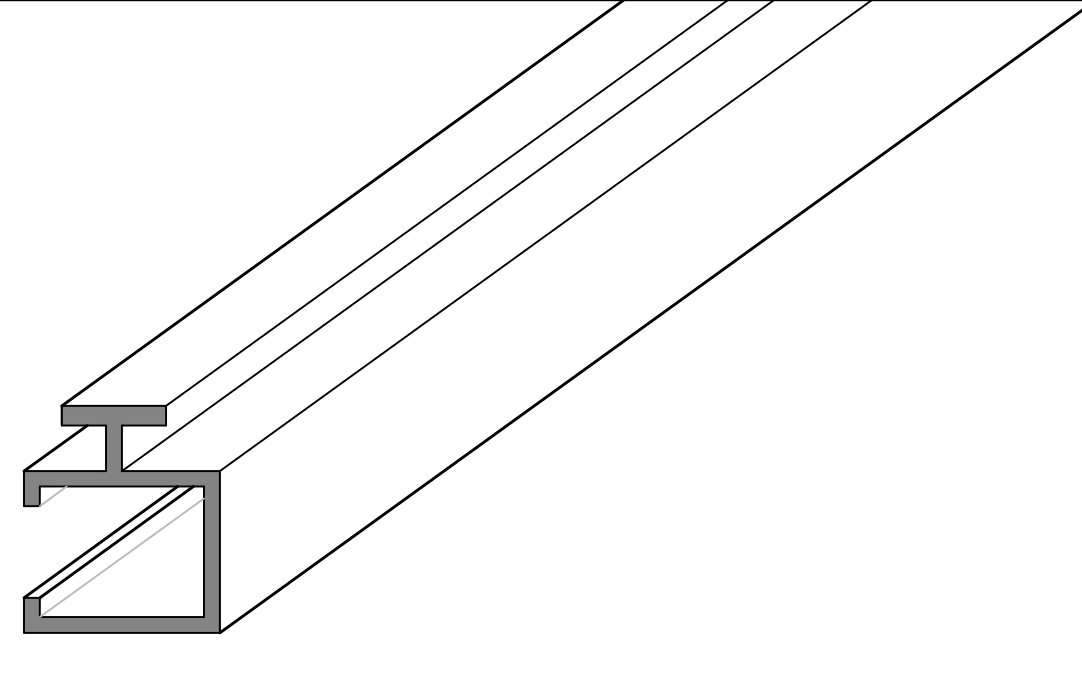
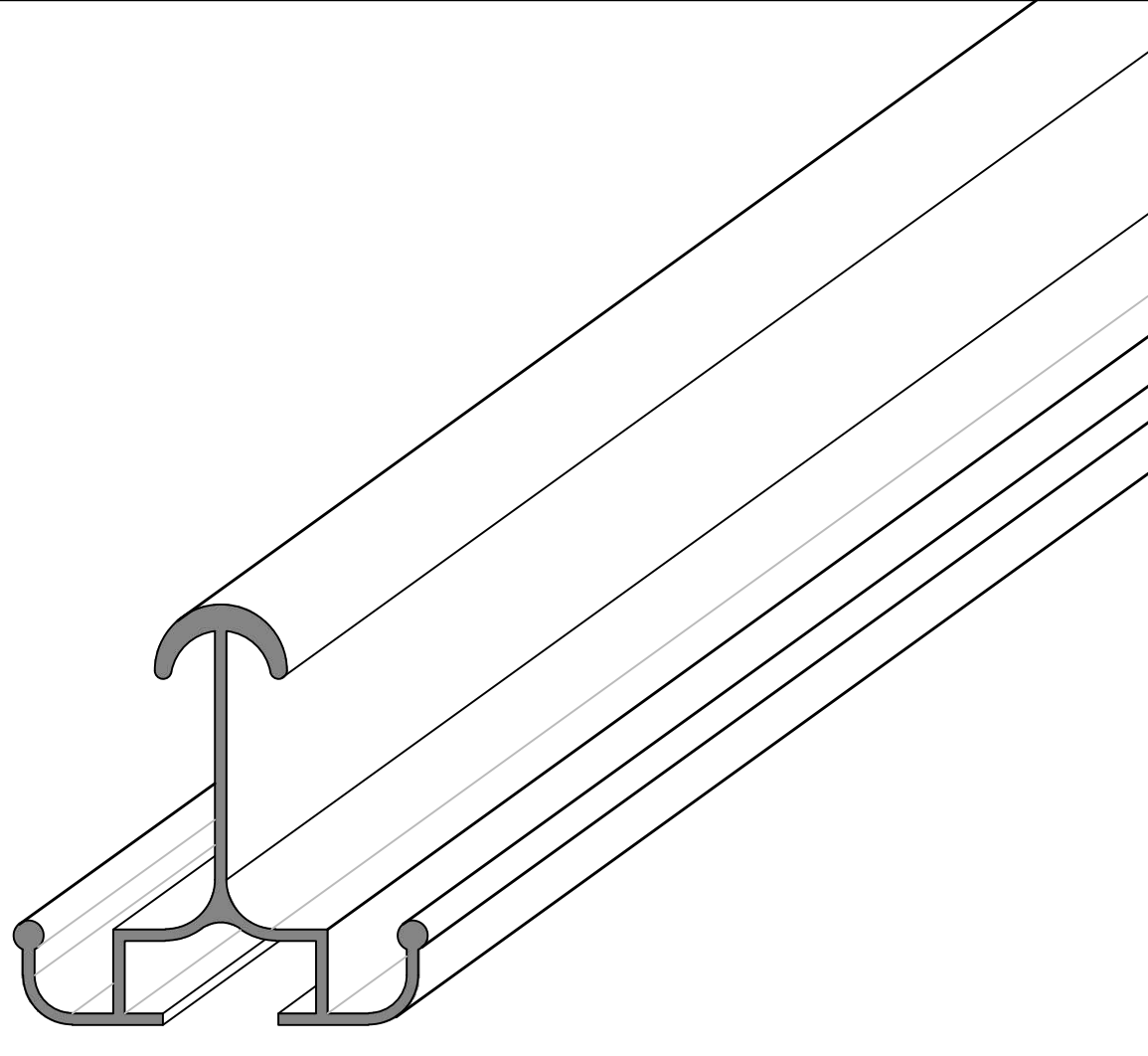
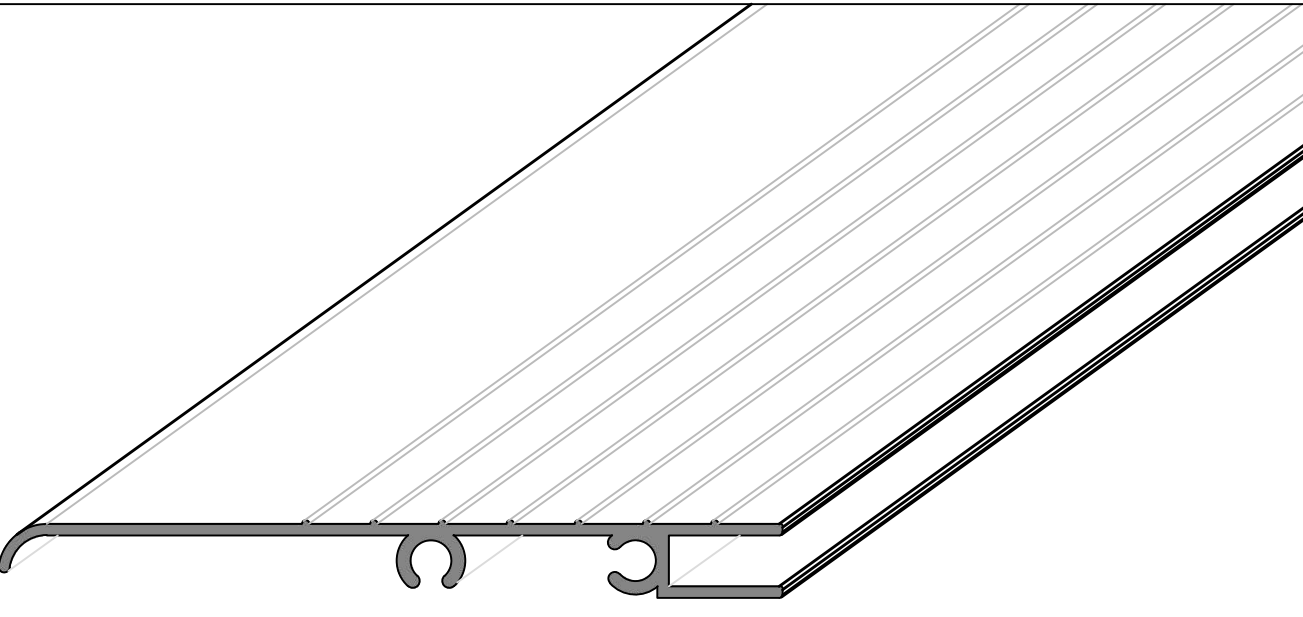
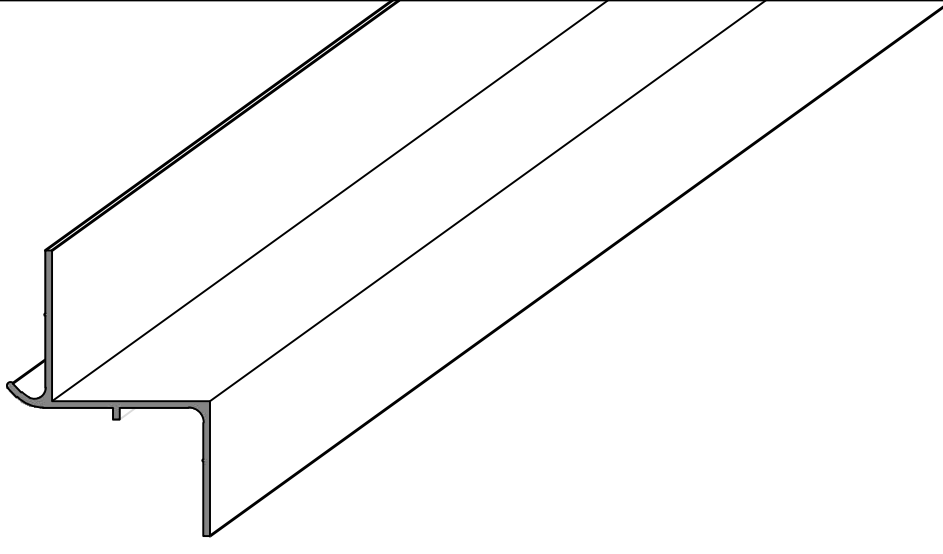
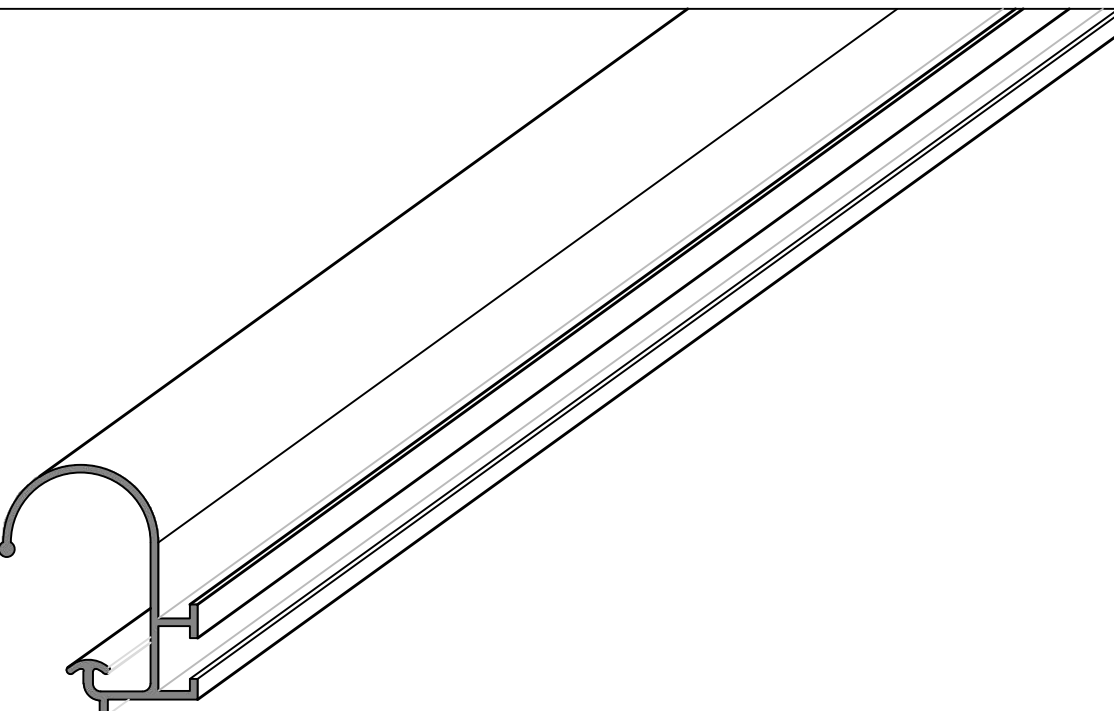
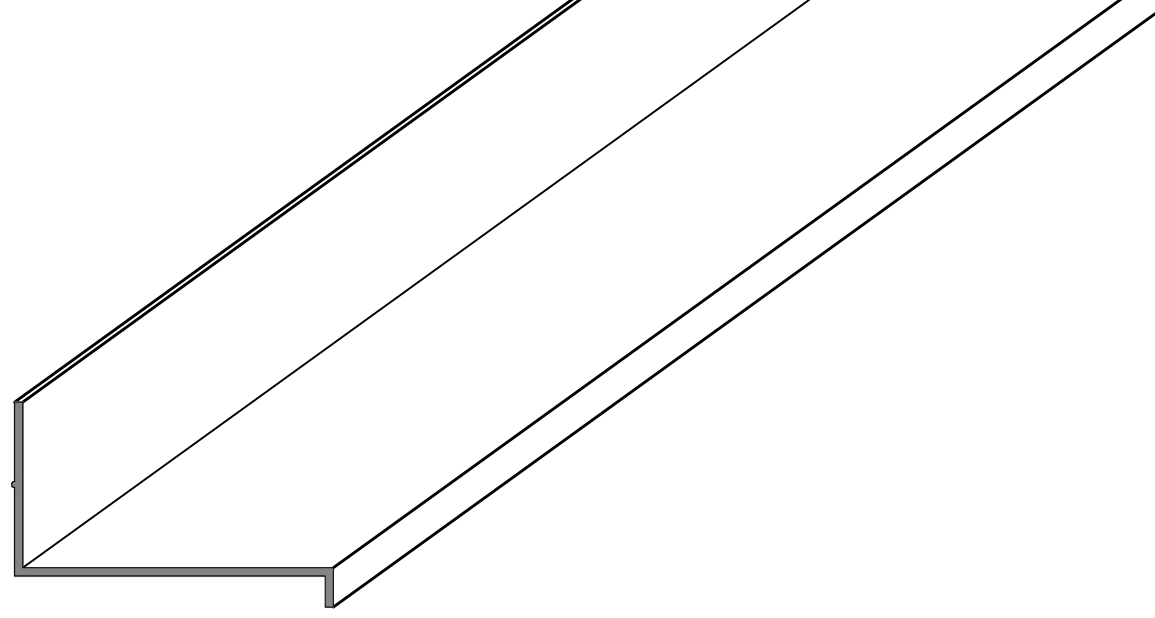
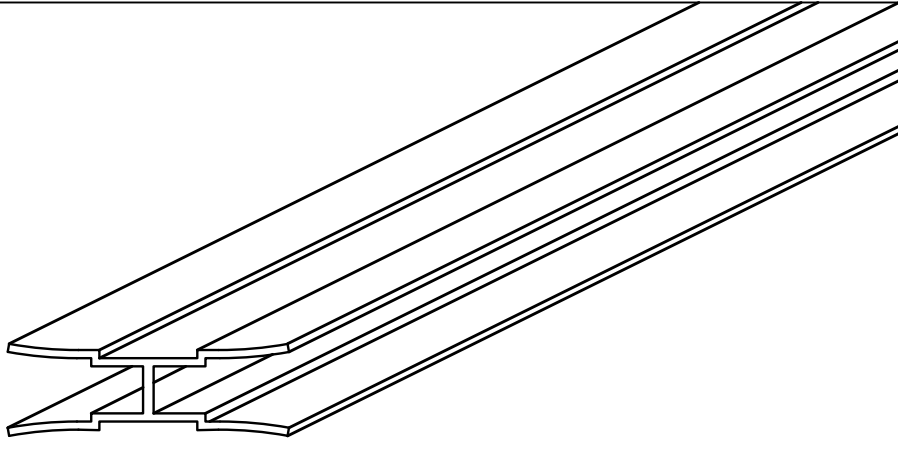
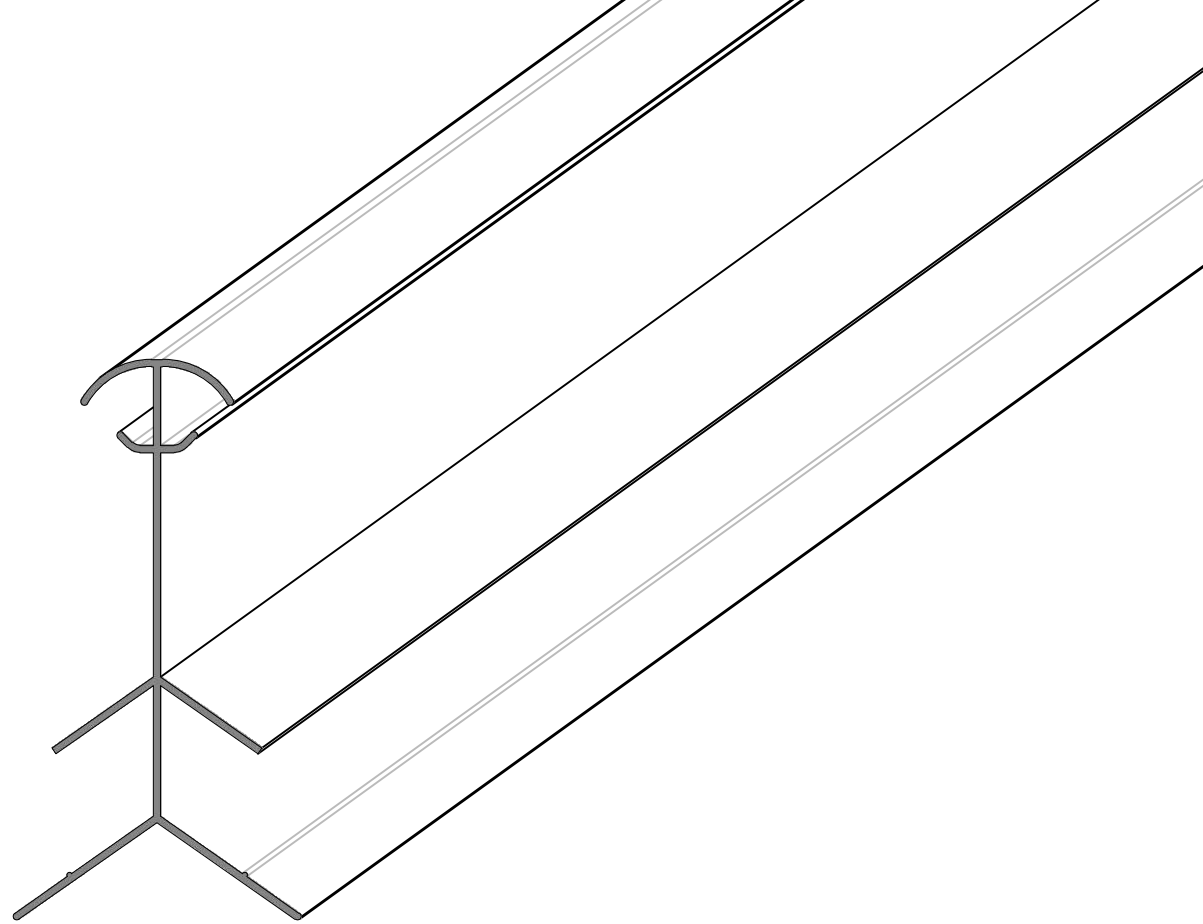
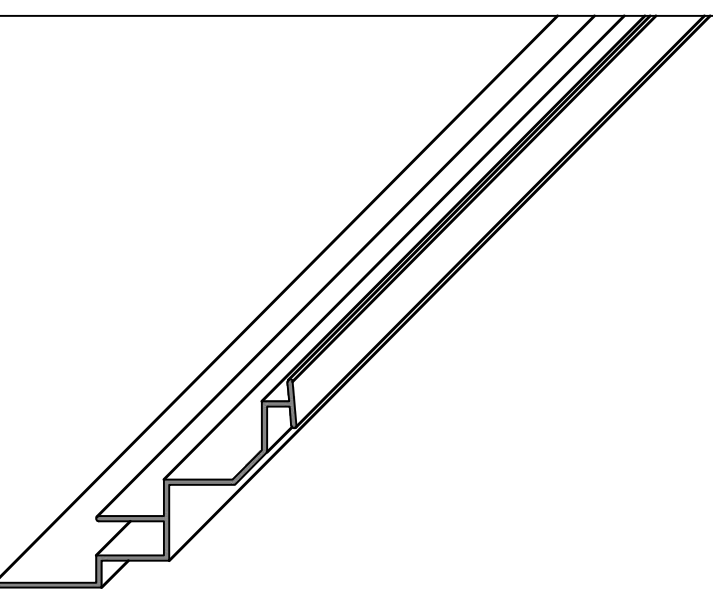
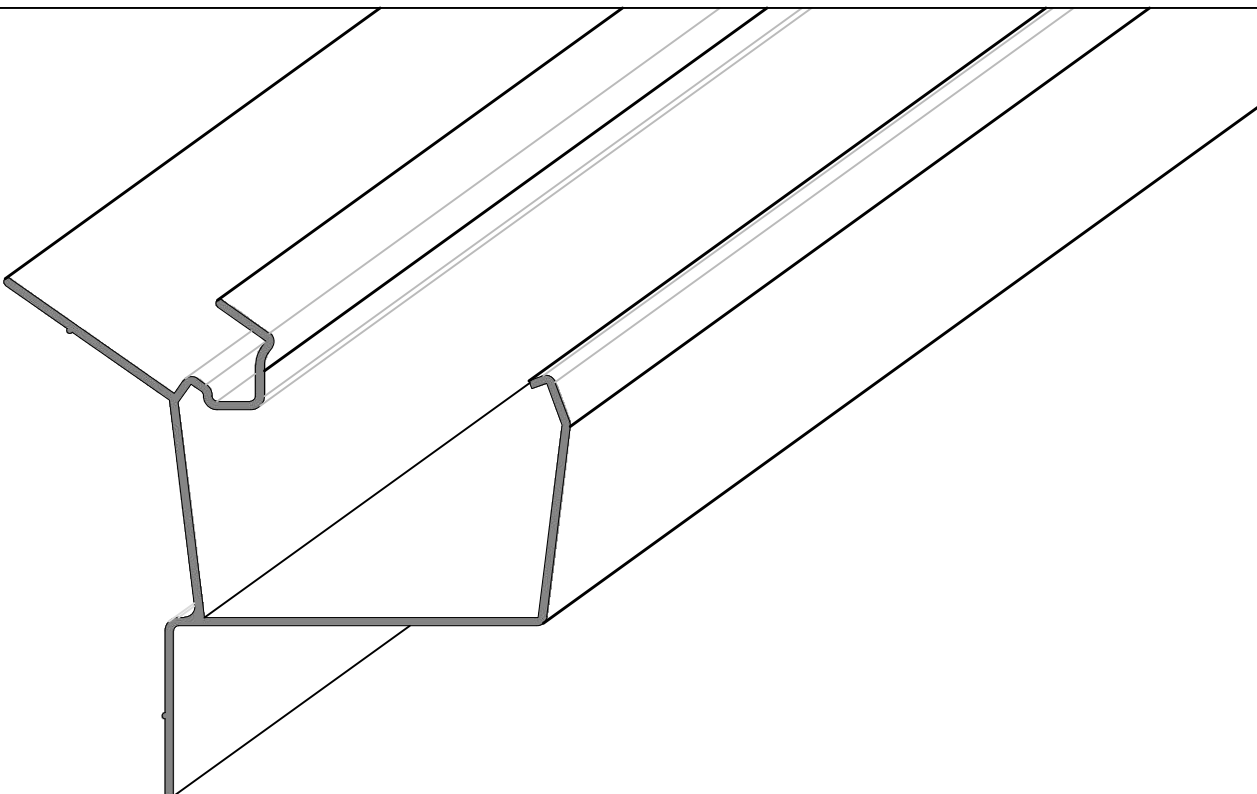
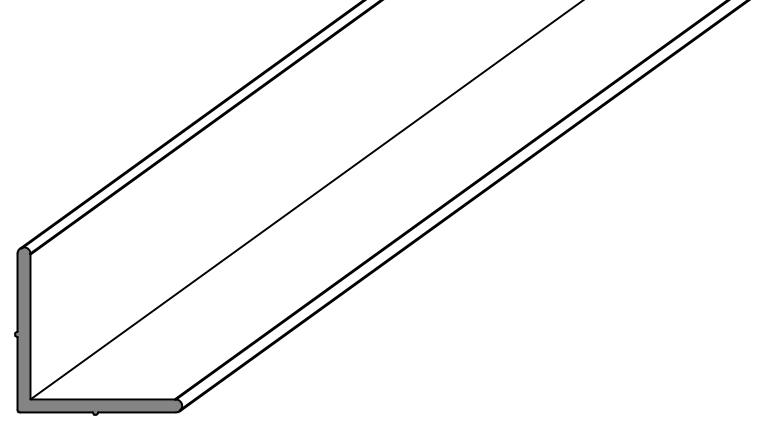
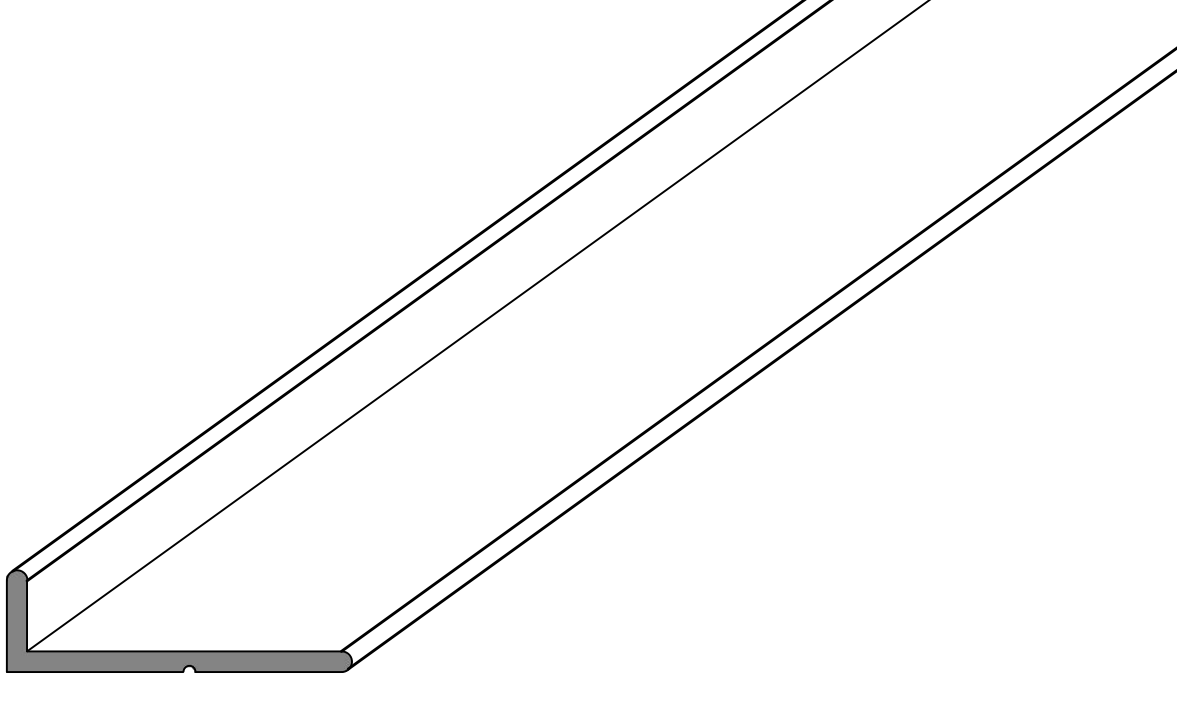
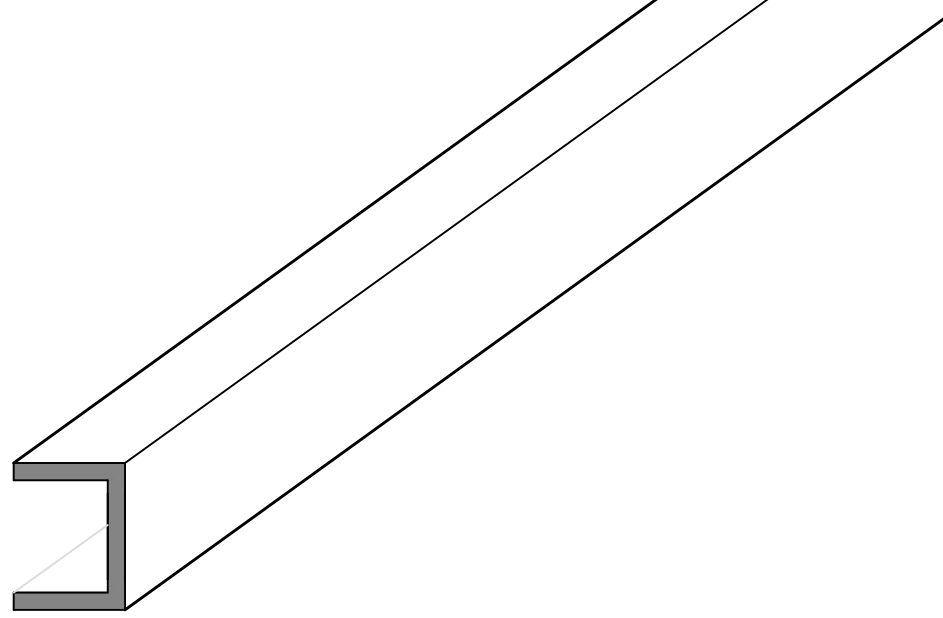
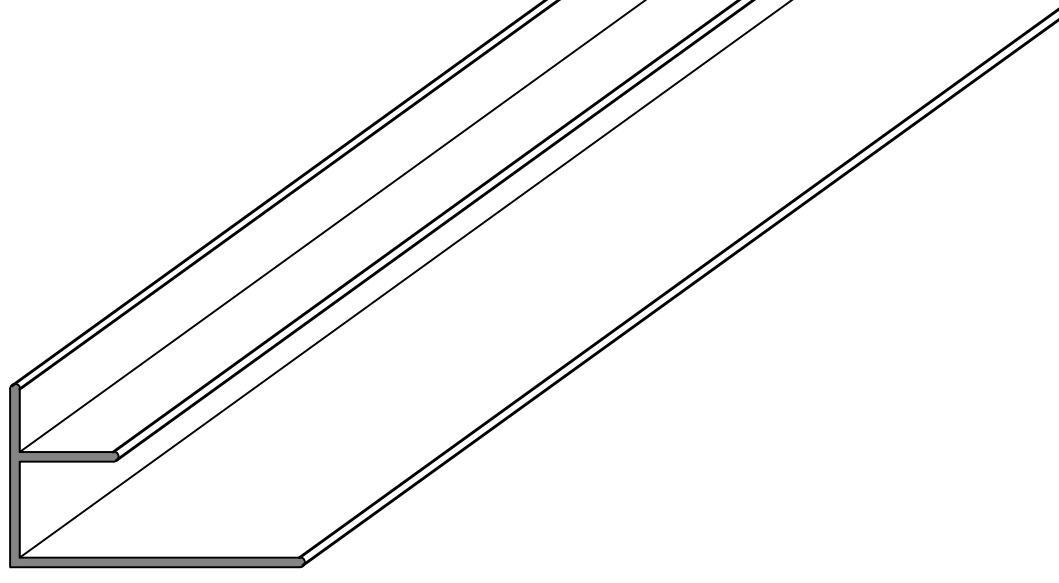
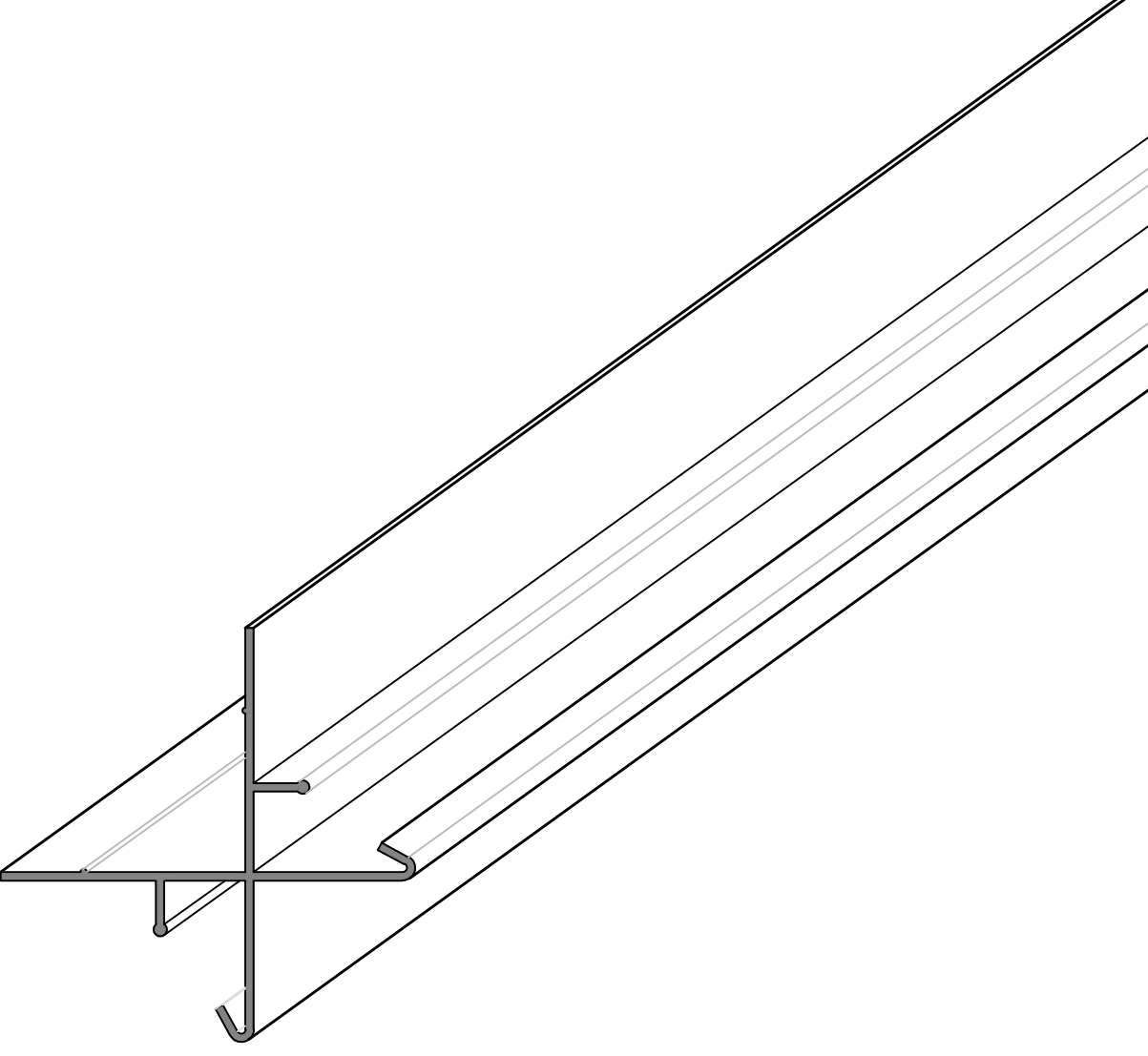
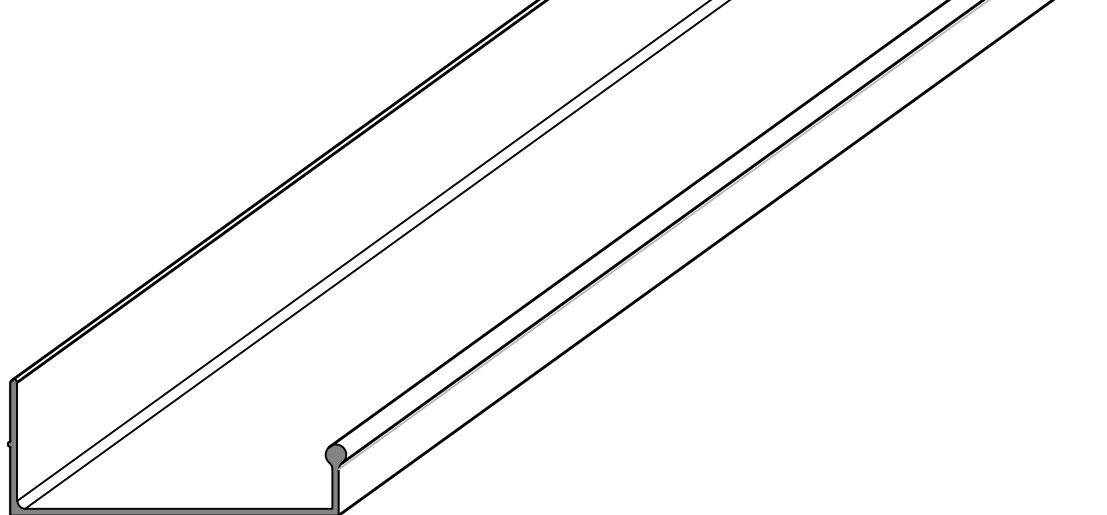

IT In caso di difficoltà durante il montaggio, allentare innanzitutto le viti prima della regolazione, quindi stringere nuovamente le viti.

PARTS LIST OF SF190

PART	NO.	Qty.	MM	PART	NO.	Qty.	MM
	D1	1	1617		10L	1	1664
	D4	1	1617		10R	1	1664
	D2	1	621		19	4	1215
	D3	3	621		20	4	1113
	13	1	635	5	1	1830	
	18	1	1245		4	2	1830
	9L	1	1641			15	5
9R	1	1641		17		1	1830
	W1	1		590		8	2
	W2	2	522			25	1
W3	1	590			12	2	596
	W4	1		380	14	1	1824
		21		1	623	22	4
						23	2
	7		4			1215	
	16-1		1			1130	
	16-2		1			1130	
				16-3	1	1130	
				16-4	1	1130	
				6	1	1830	

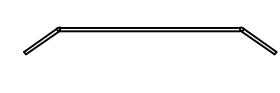
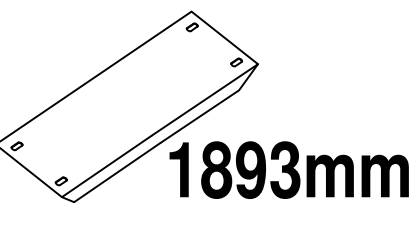
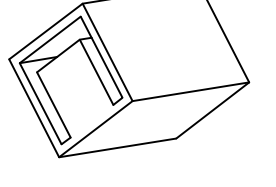
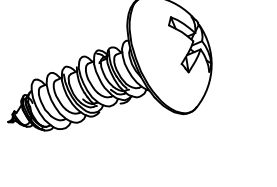
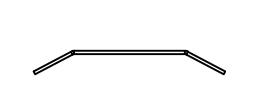
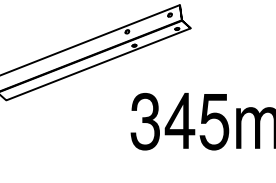
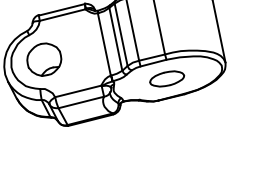
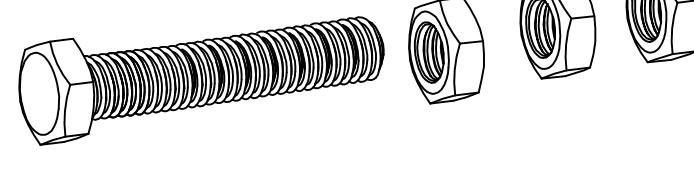
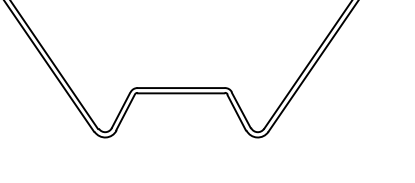
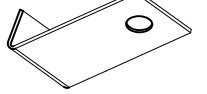
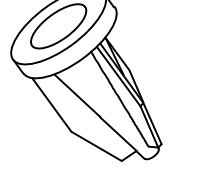
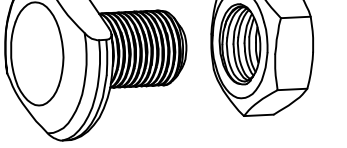
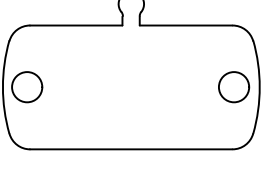
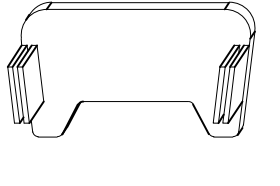
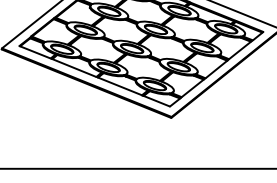
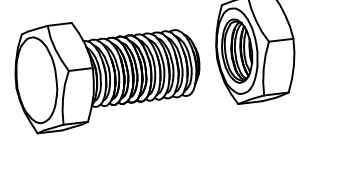
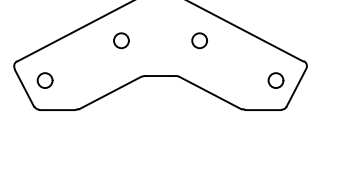
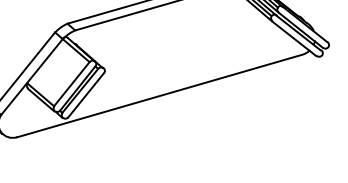
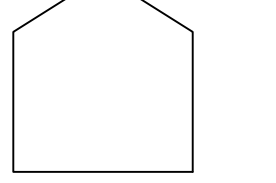
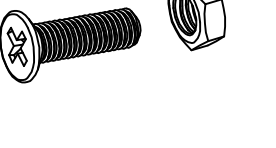
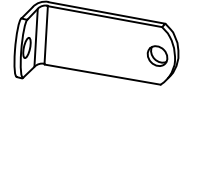
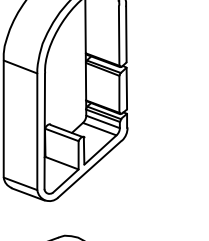
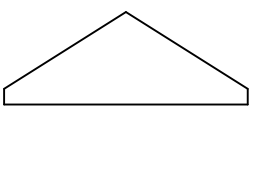
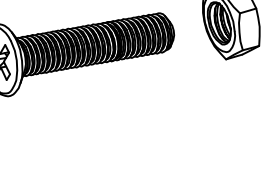
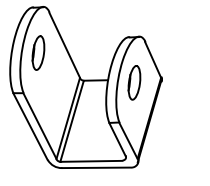
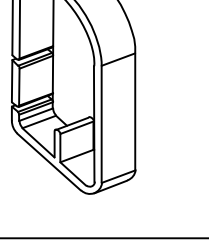
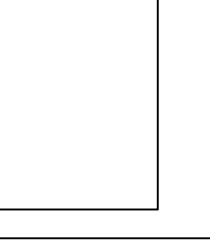
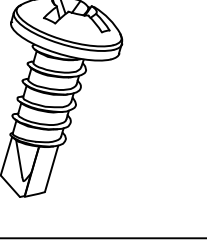
PART

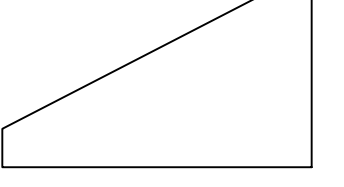
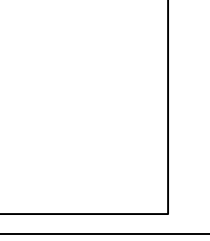
PARTS LIST OF SF190

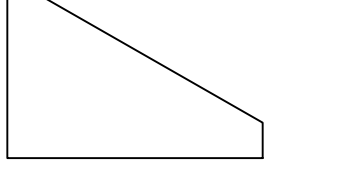
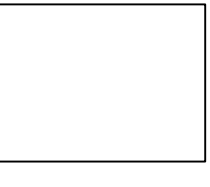
NO.	Qty.		NO.	Qty.		NO.	Qty.		NO.	Qty.	
T1	2		1	4	 1893mm	S8	1		F1	10	ST4.2- 9mm 
T2	4		3	4	 345mm	S9	1		F3	1	5- 35mm 
B3	130		B2	16		S11	100		F4	114	6- 12mm 
B4	1		S3	4		S10	9		F5	4	5- 10mm 
B5	4		S4	8		P6	1		F8	1	4-12mm 
B6	1		S7L	1		P7	1		F9	1	4-18mm 
B8	1		S7R	1		P8	11		F10	100	ST4.2-16mm 
P1	3		P4L	2		P9	5				
P2	1		P4R	2		P10	1				

PART

PARTS LIST OF SF190

SUMMARY STATEMENT FOR POLYCARBONATE PANEL

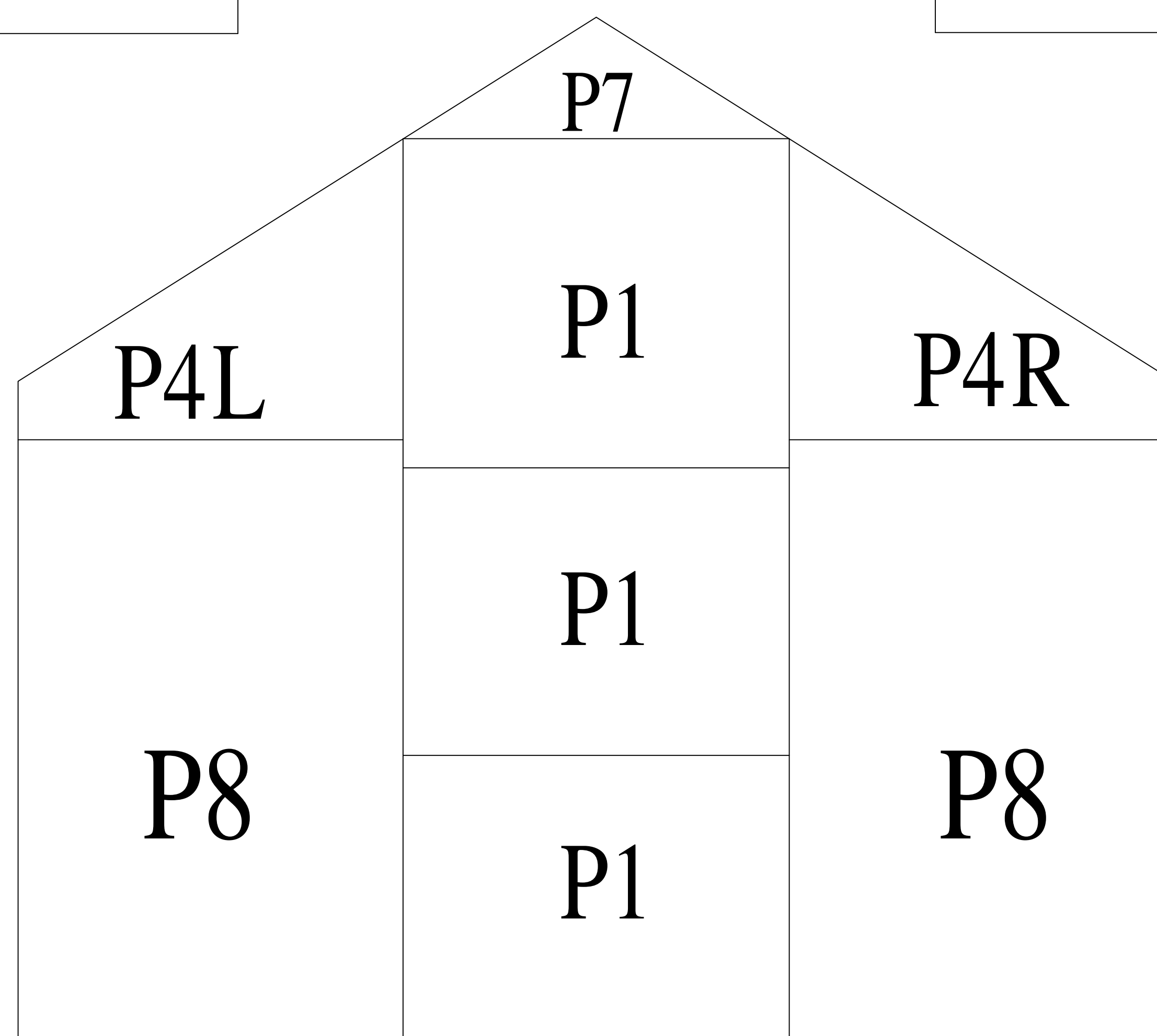
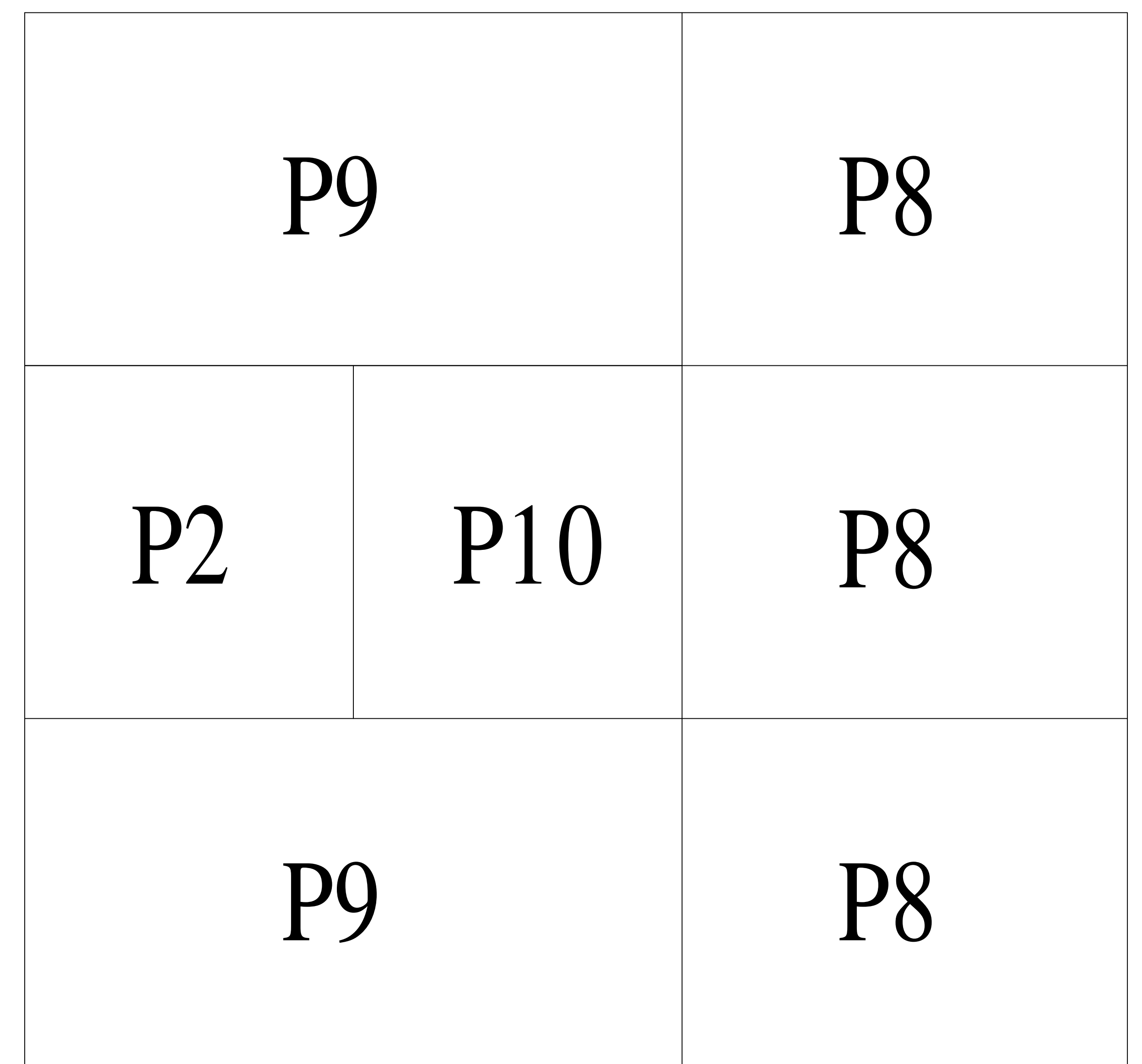
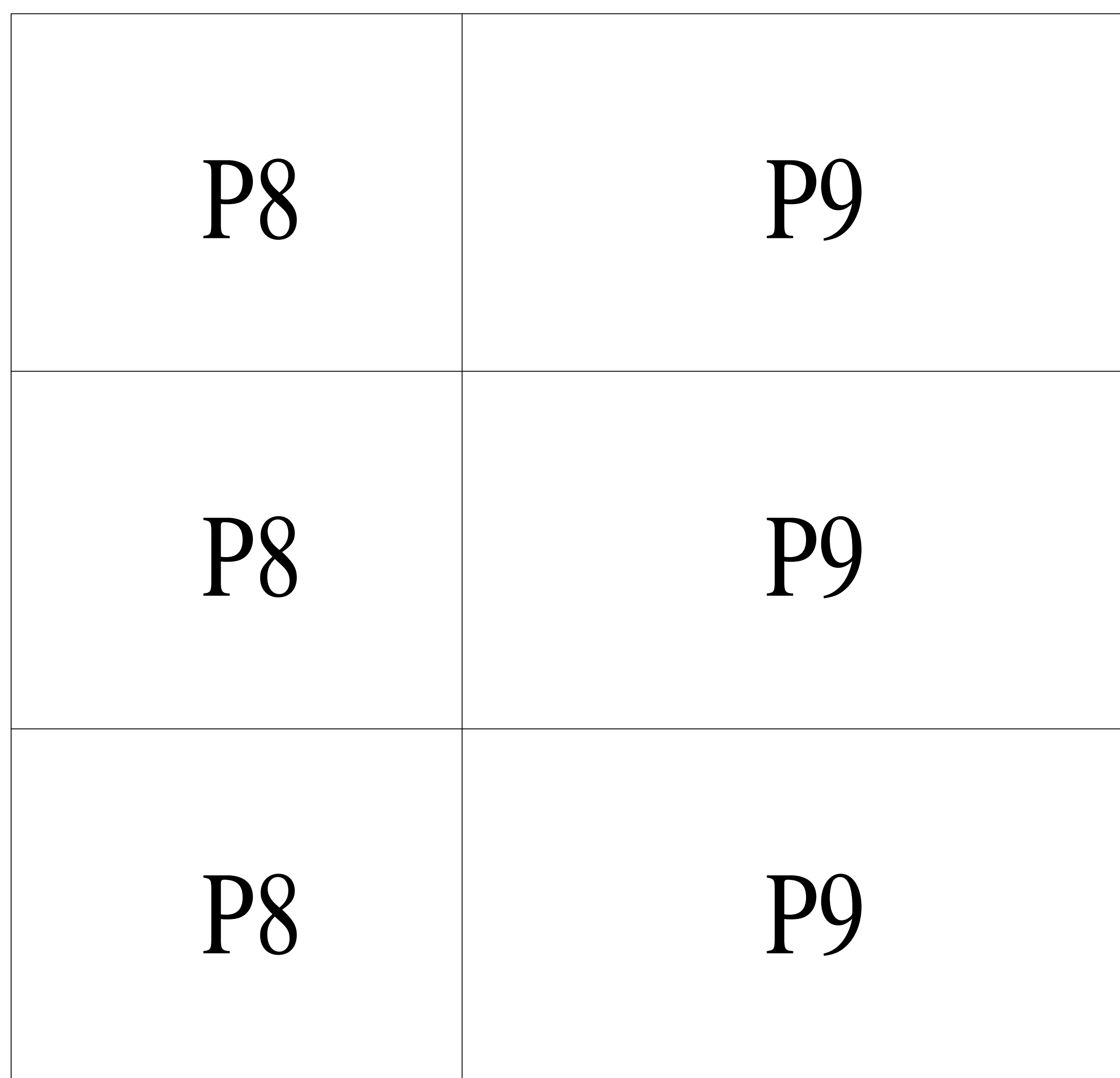
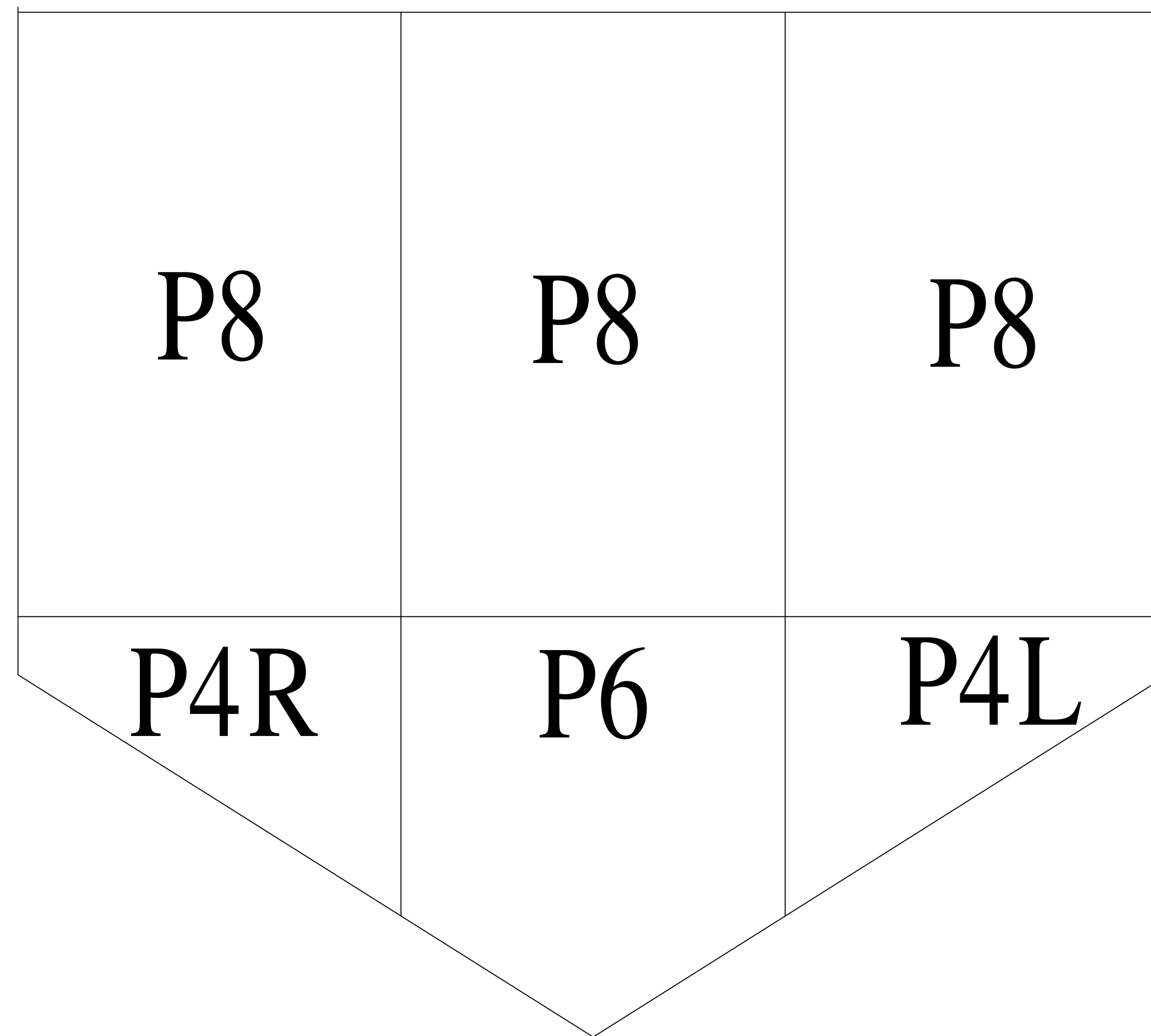

The UV-protected side of the sheet is covered with transparent film and must face towards the sun.

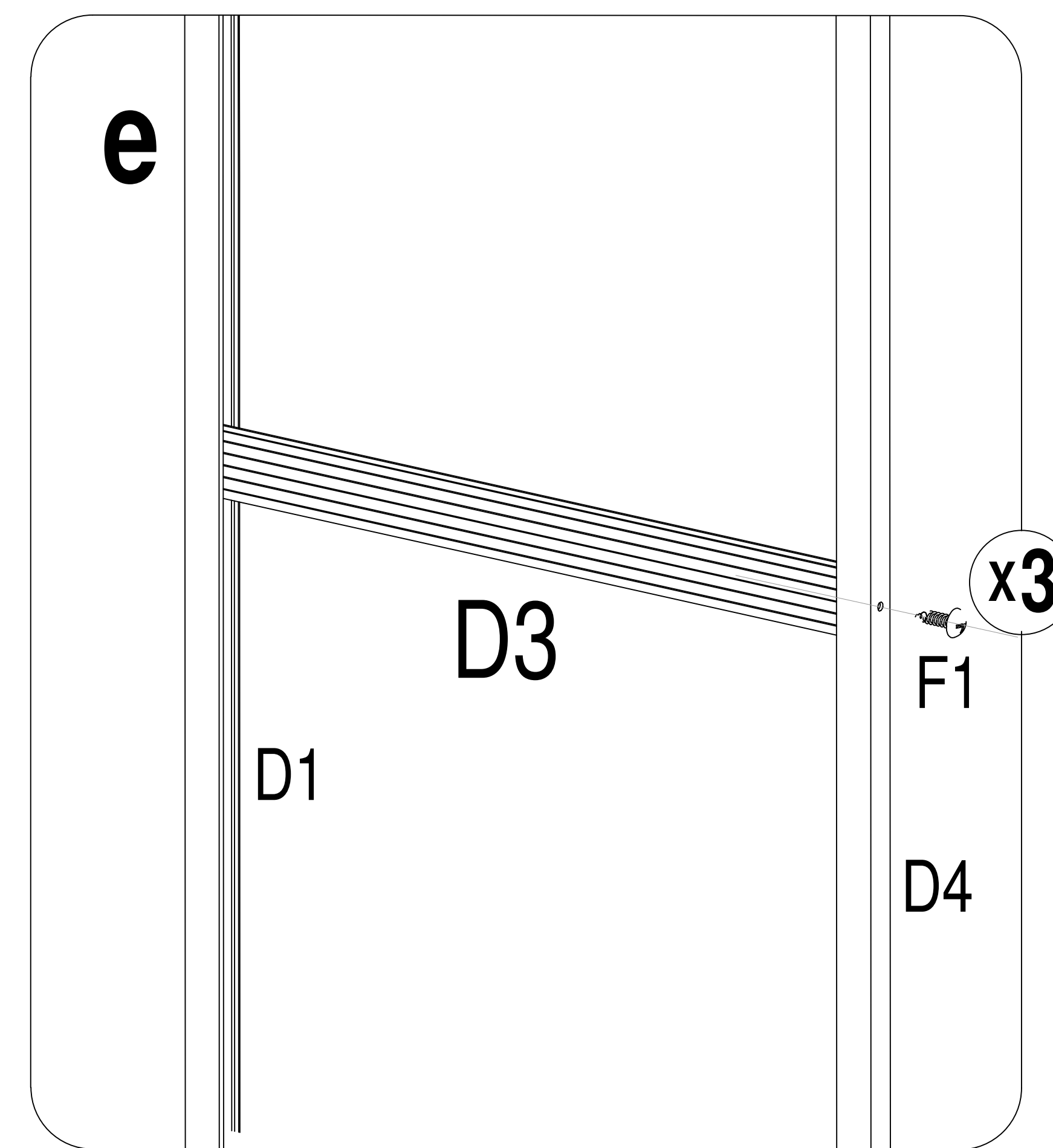
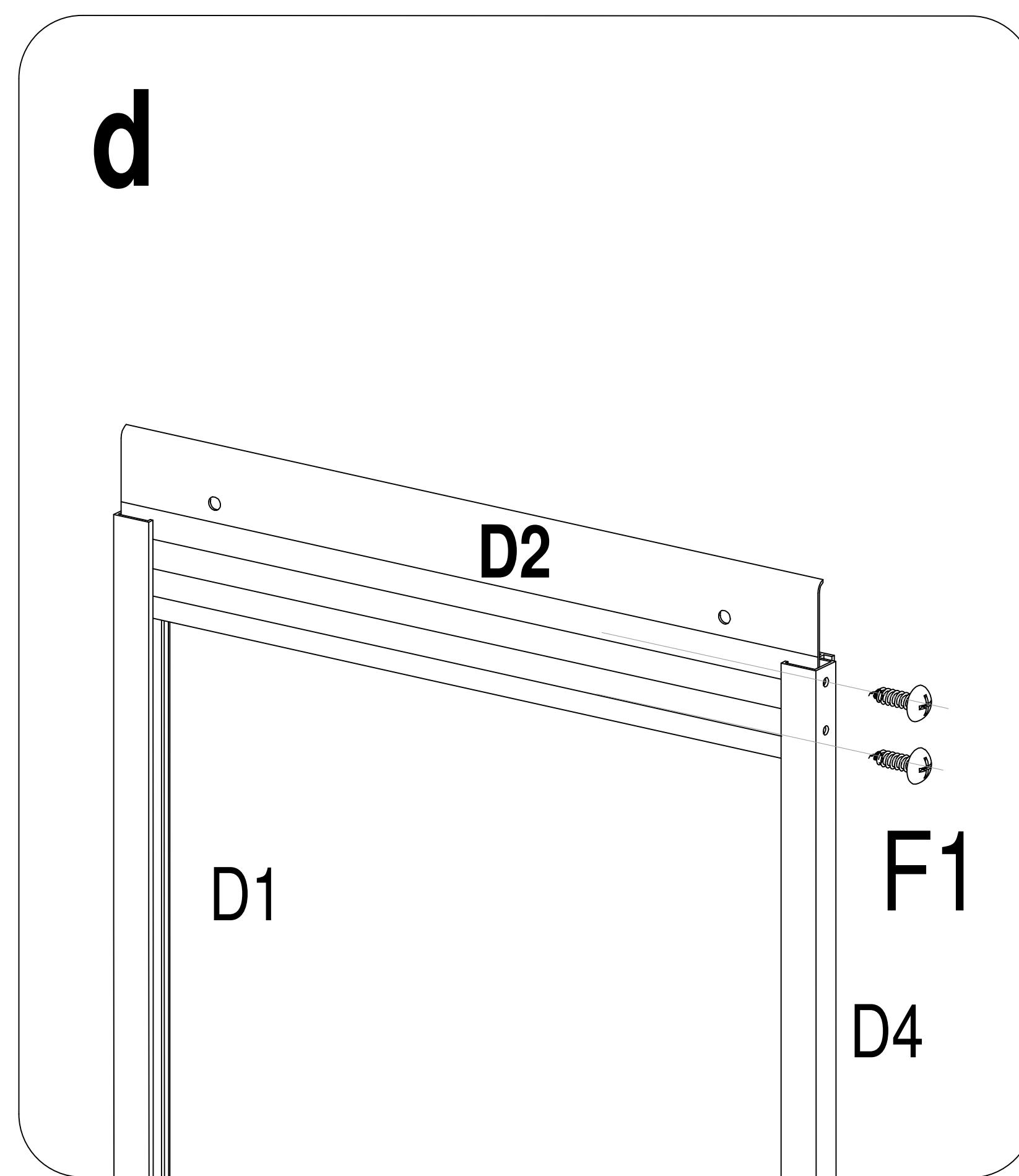
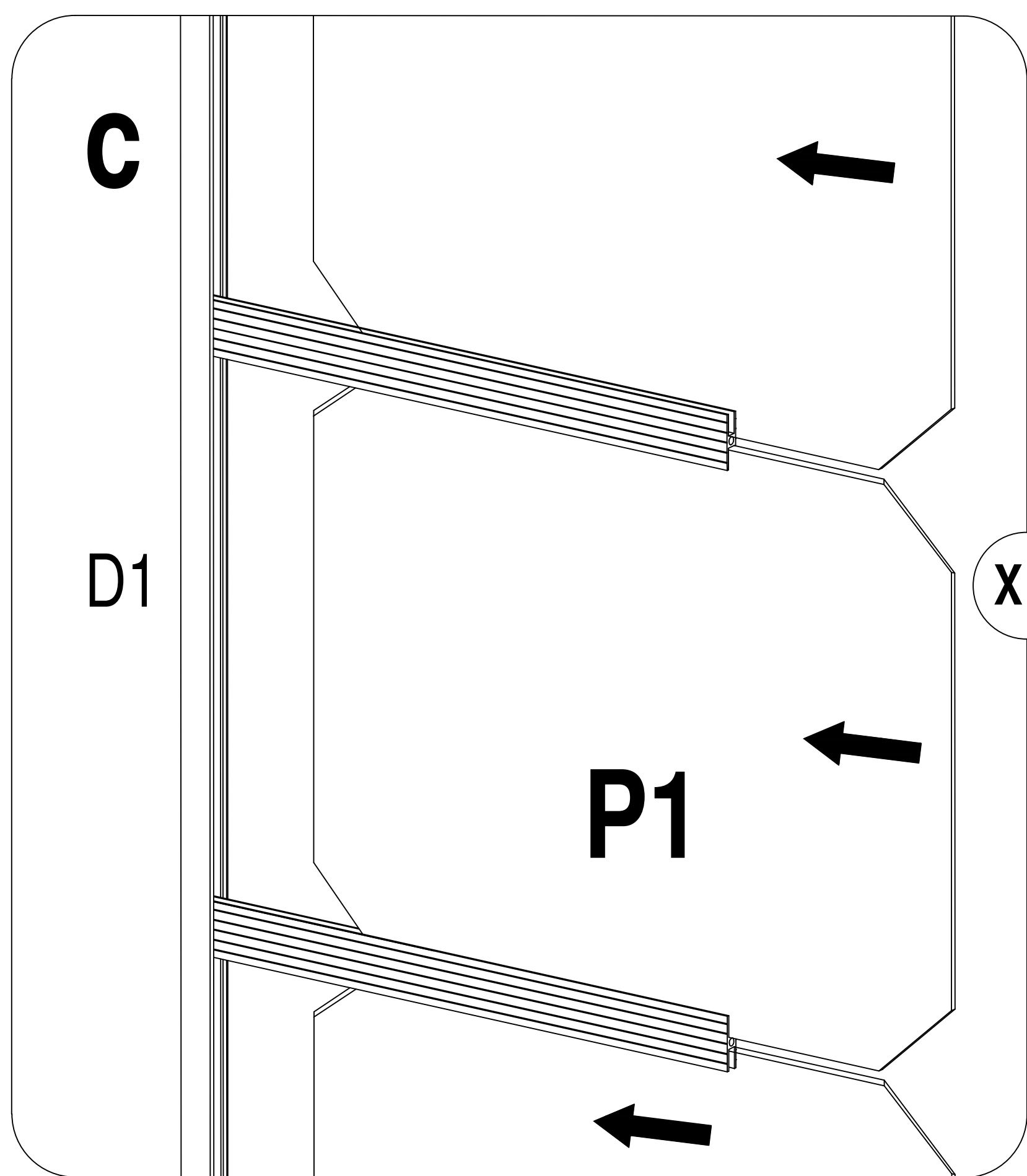
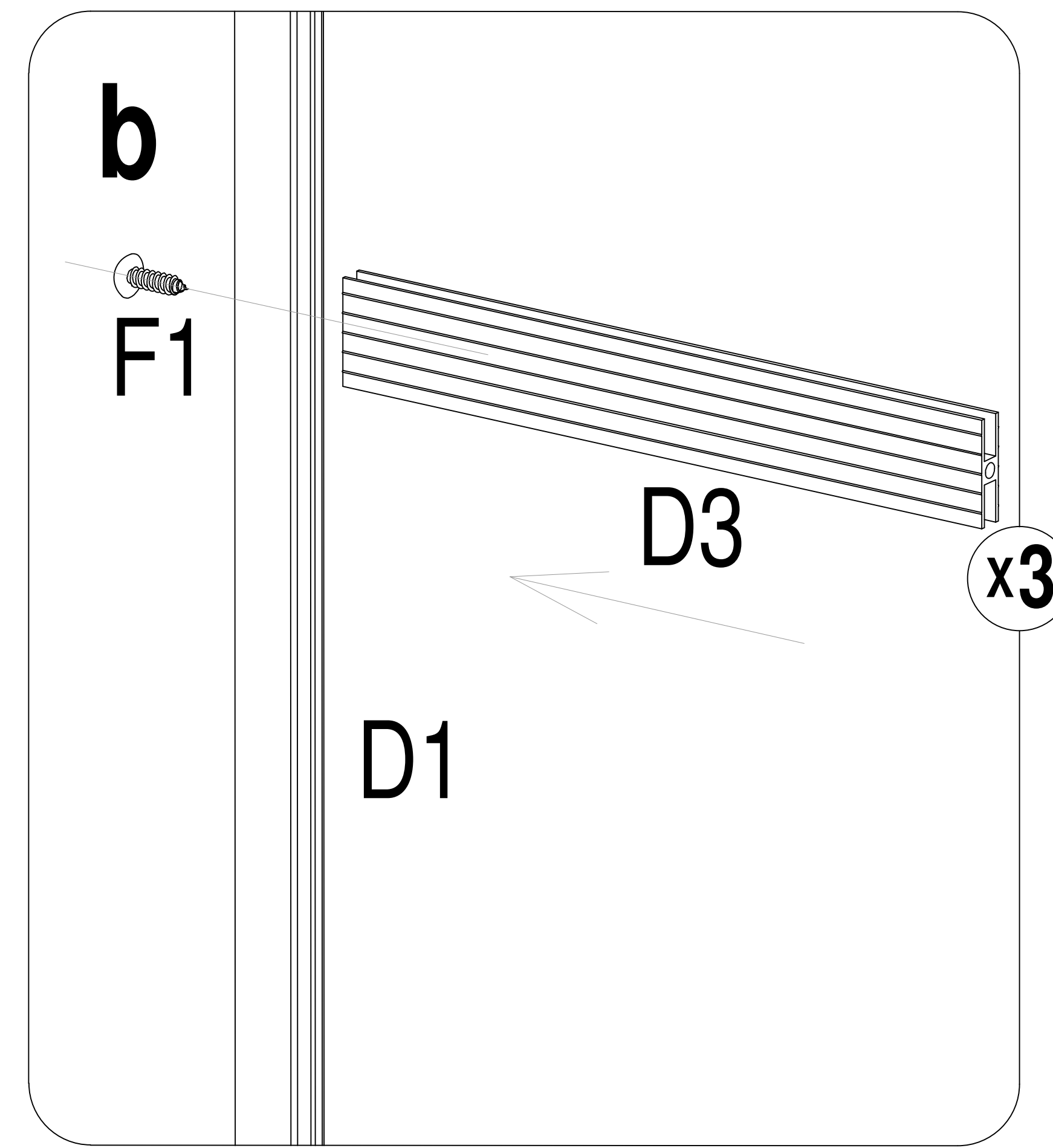
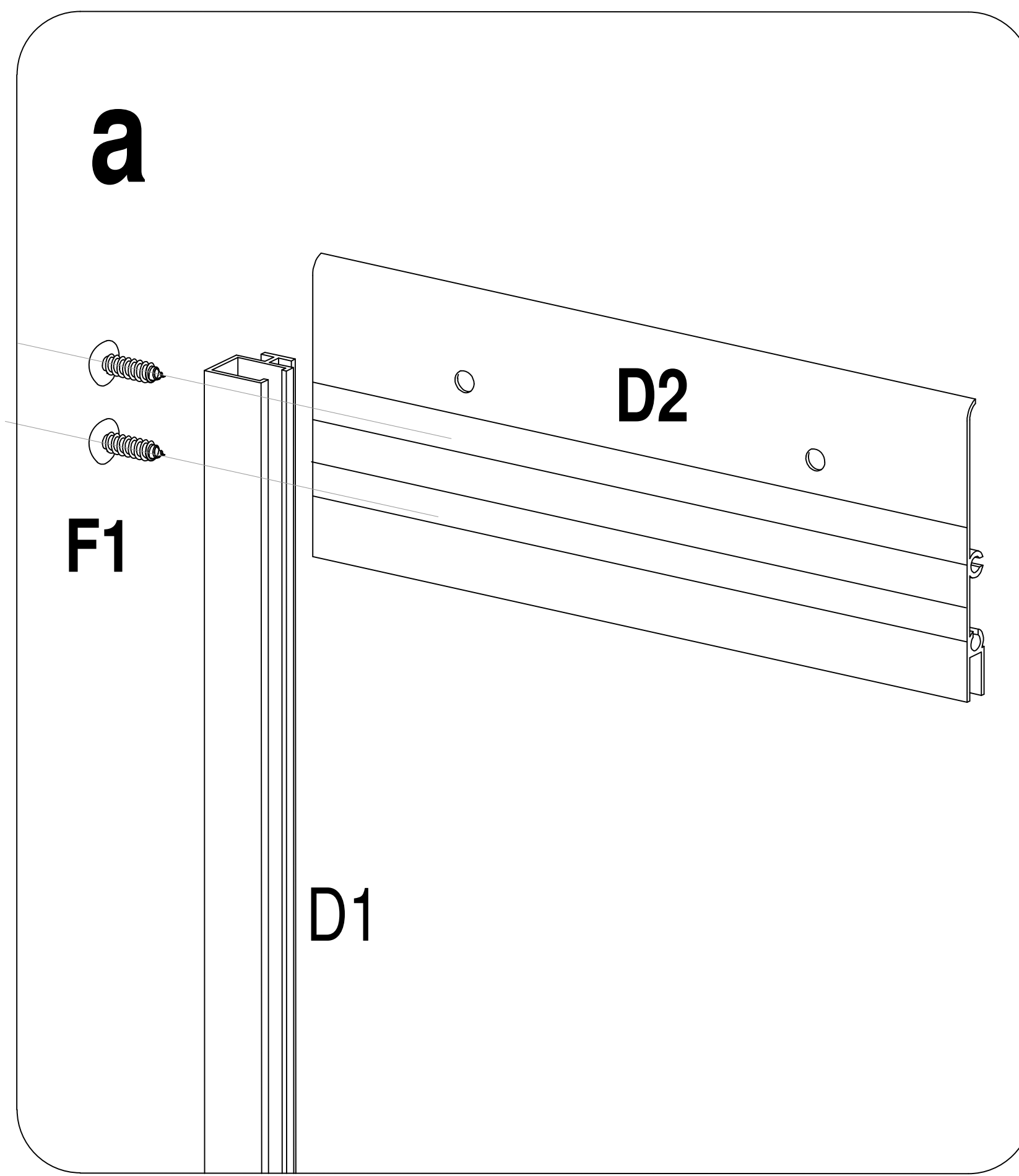
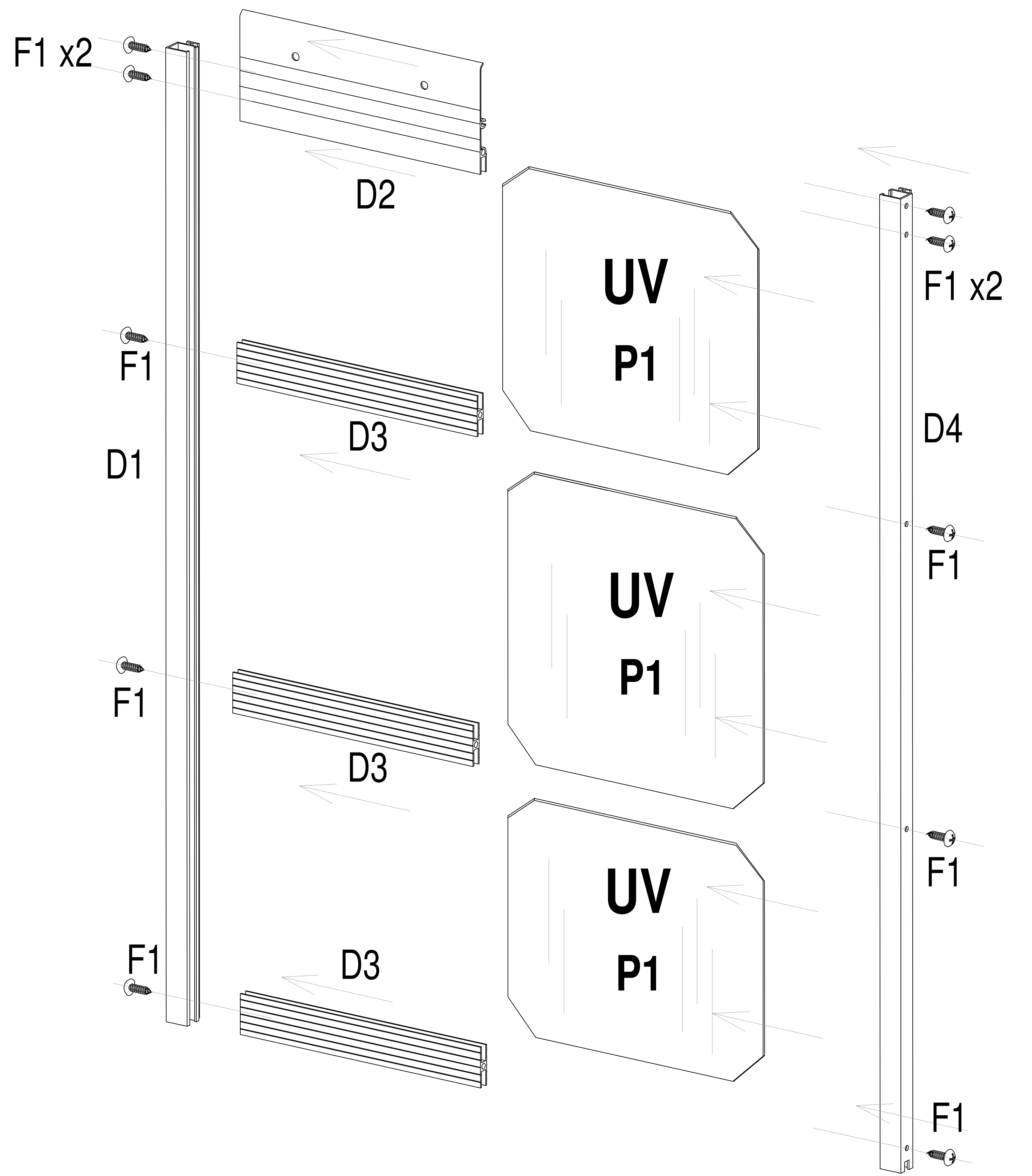
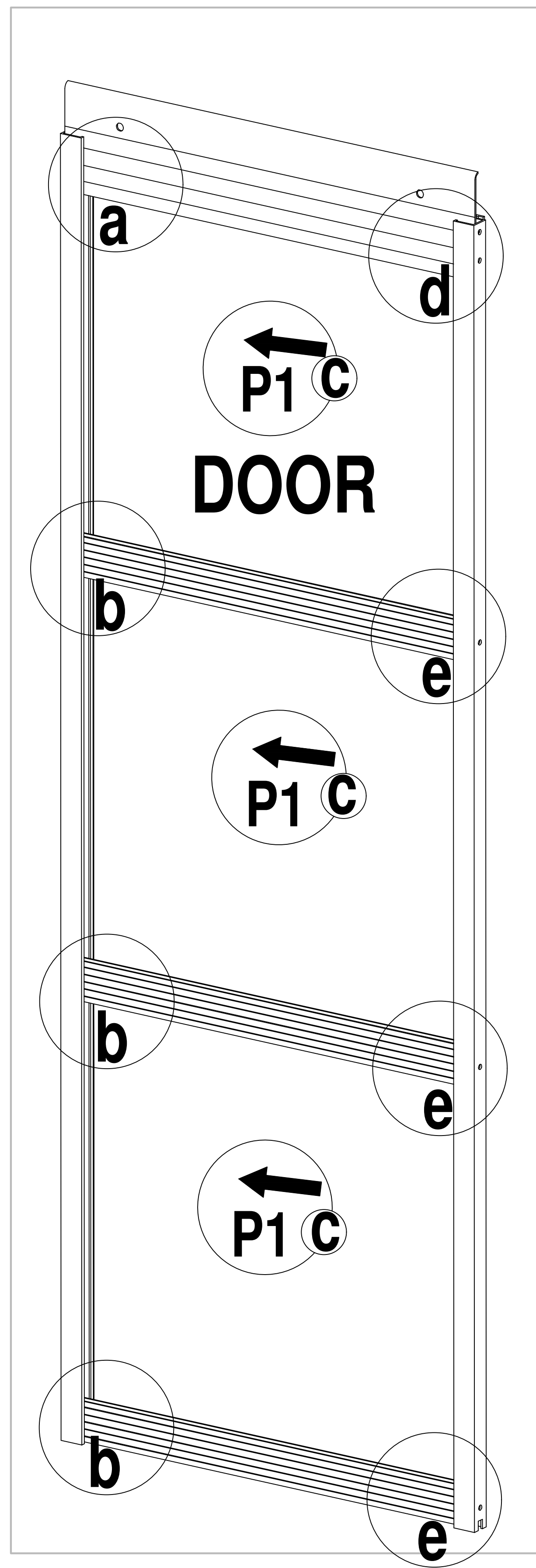
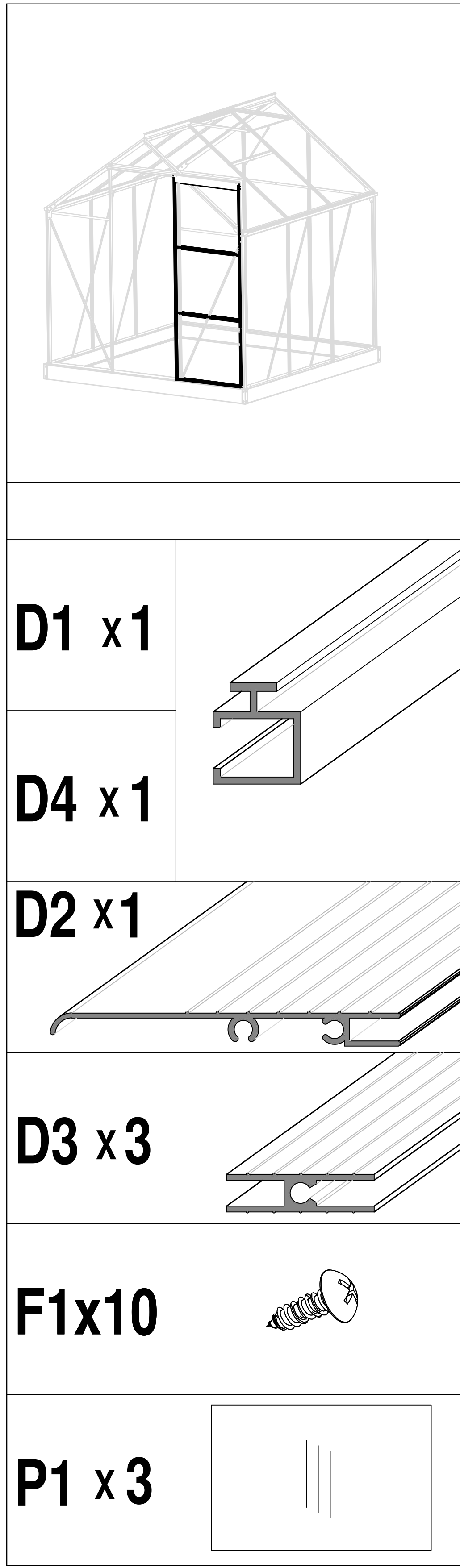

W1 x1
W2 x2
W3 x1
W4 x1
S8 x1
S9 x1
F4 x4
F8 x1
F9 x1
P2 x1

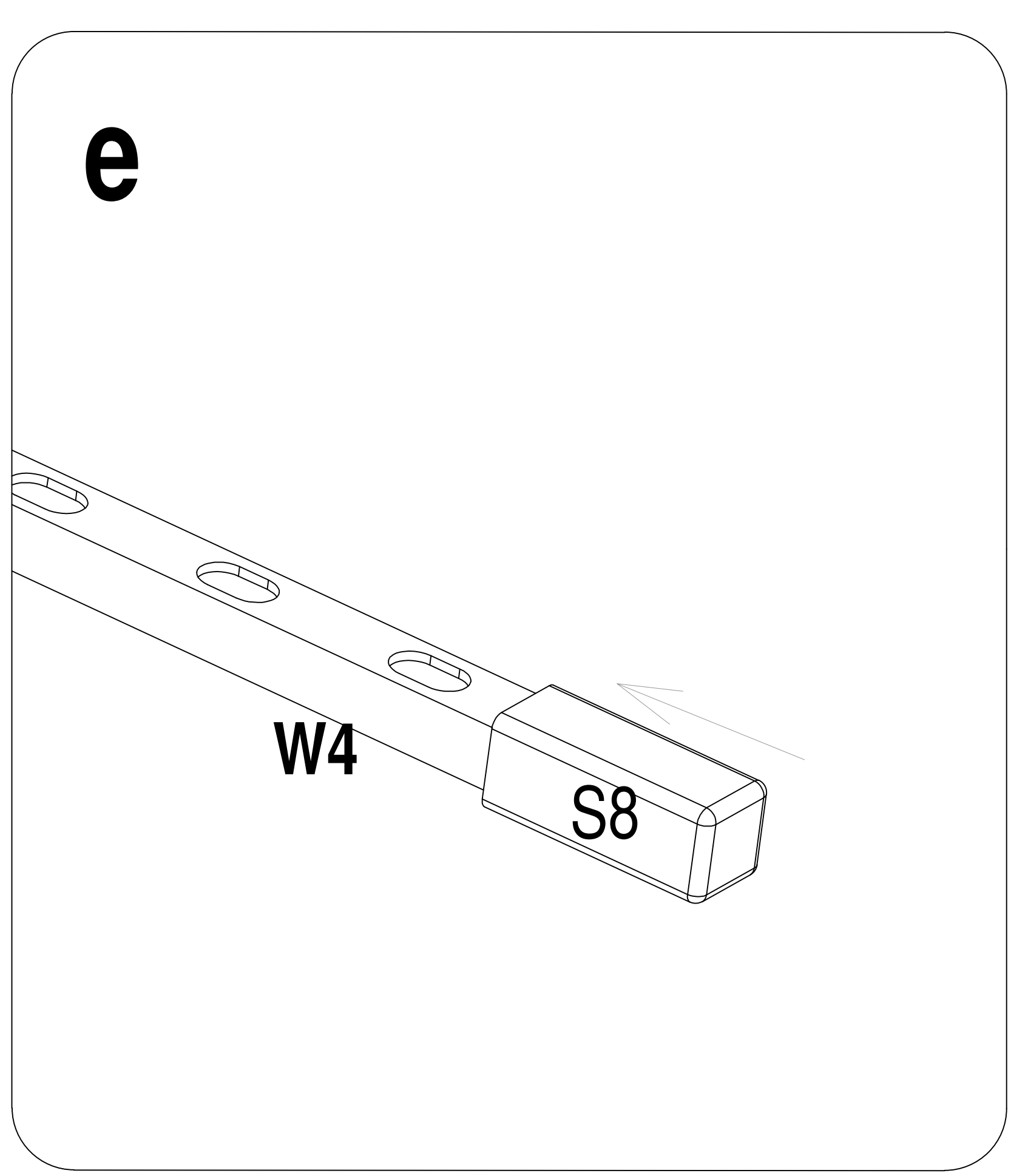
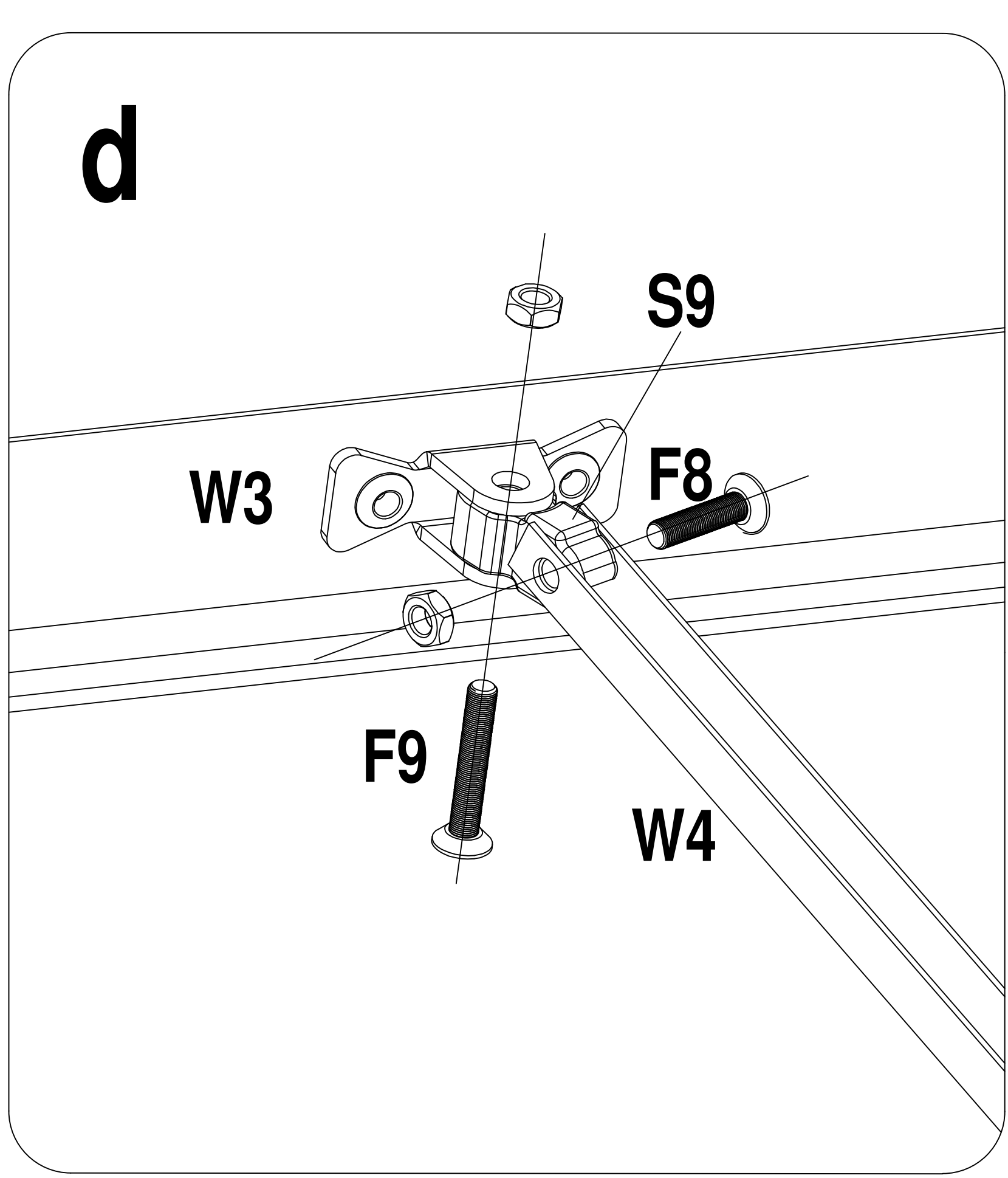
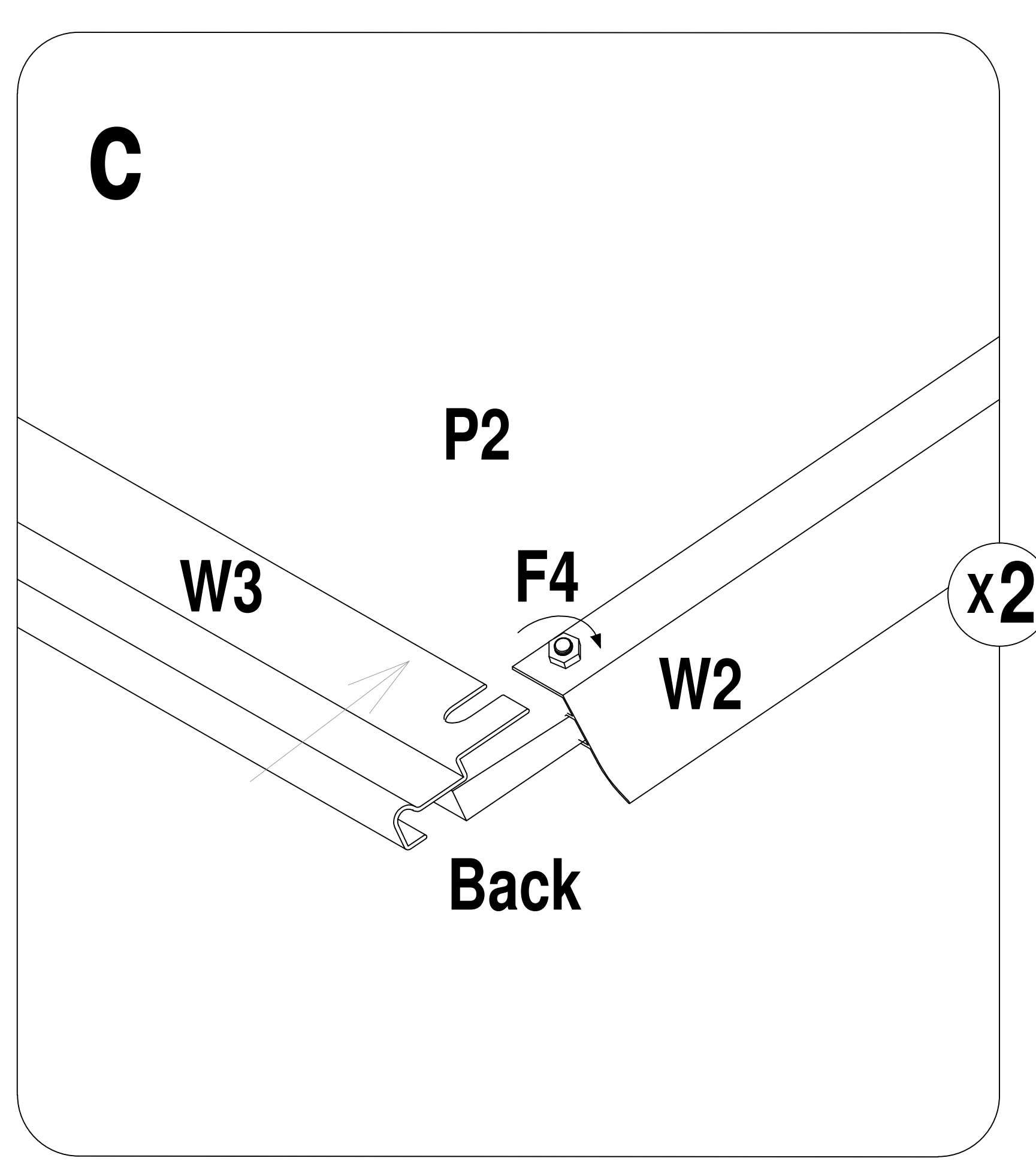
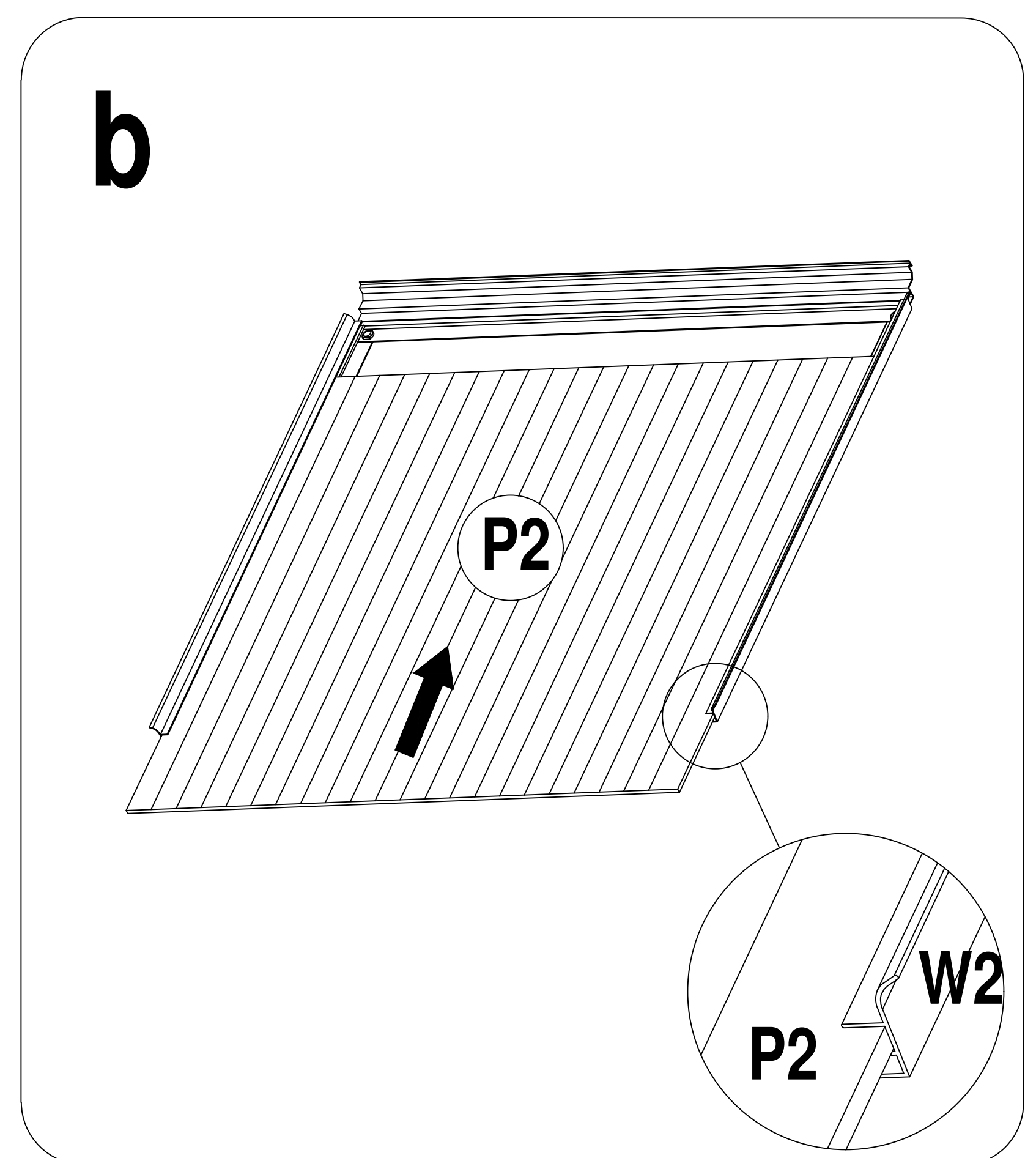
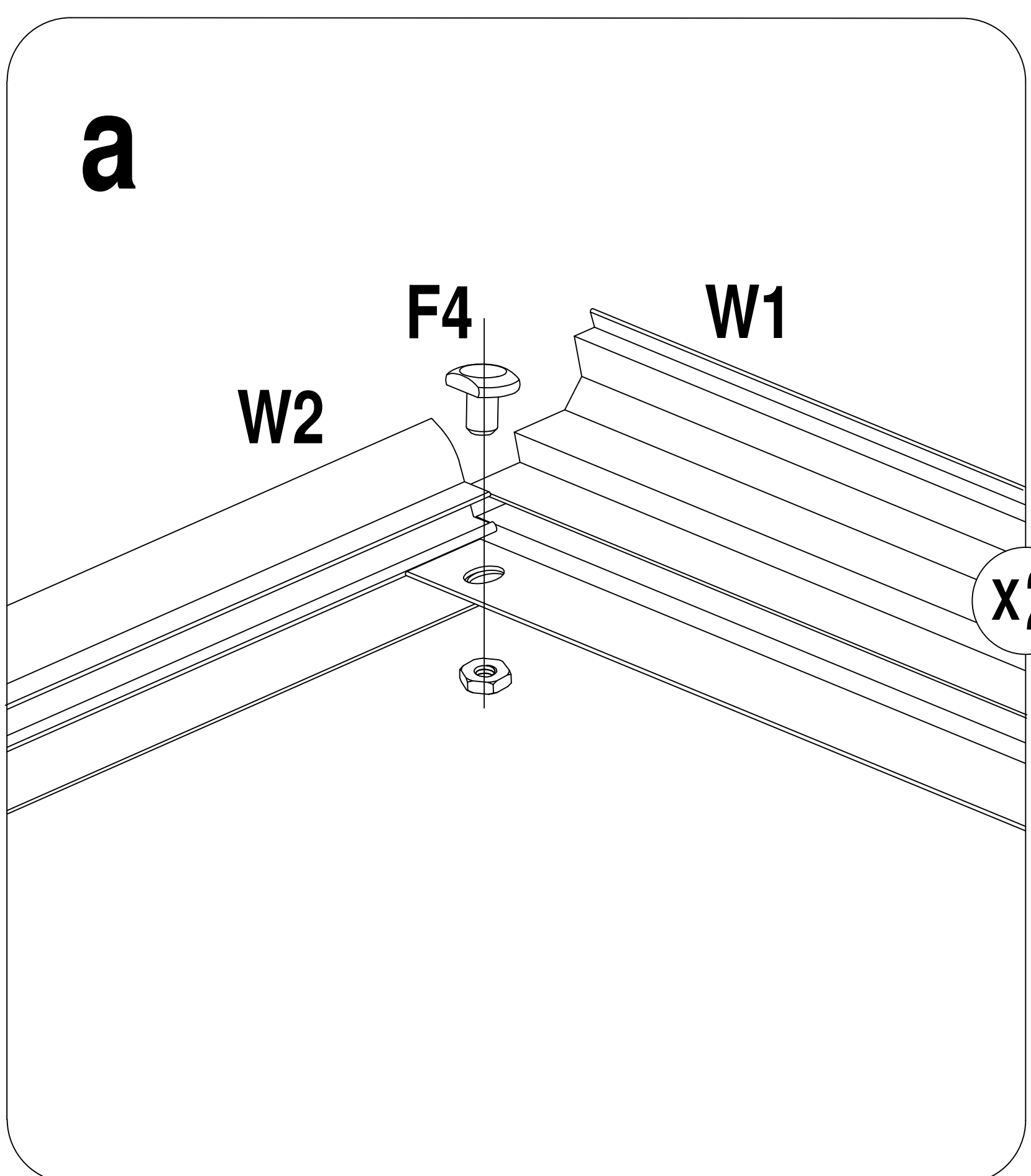
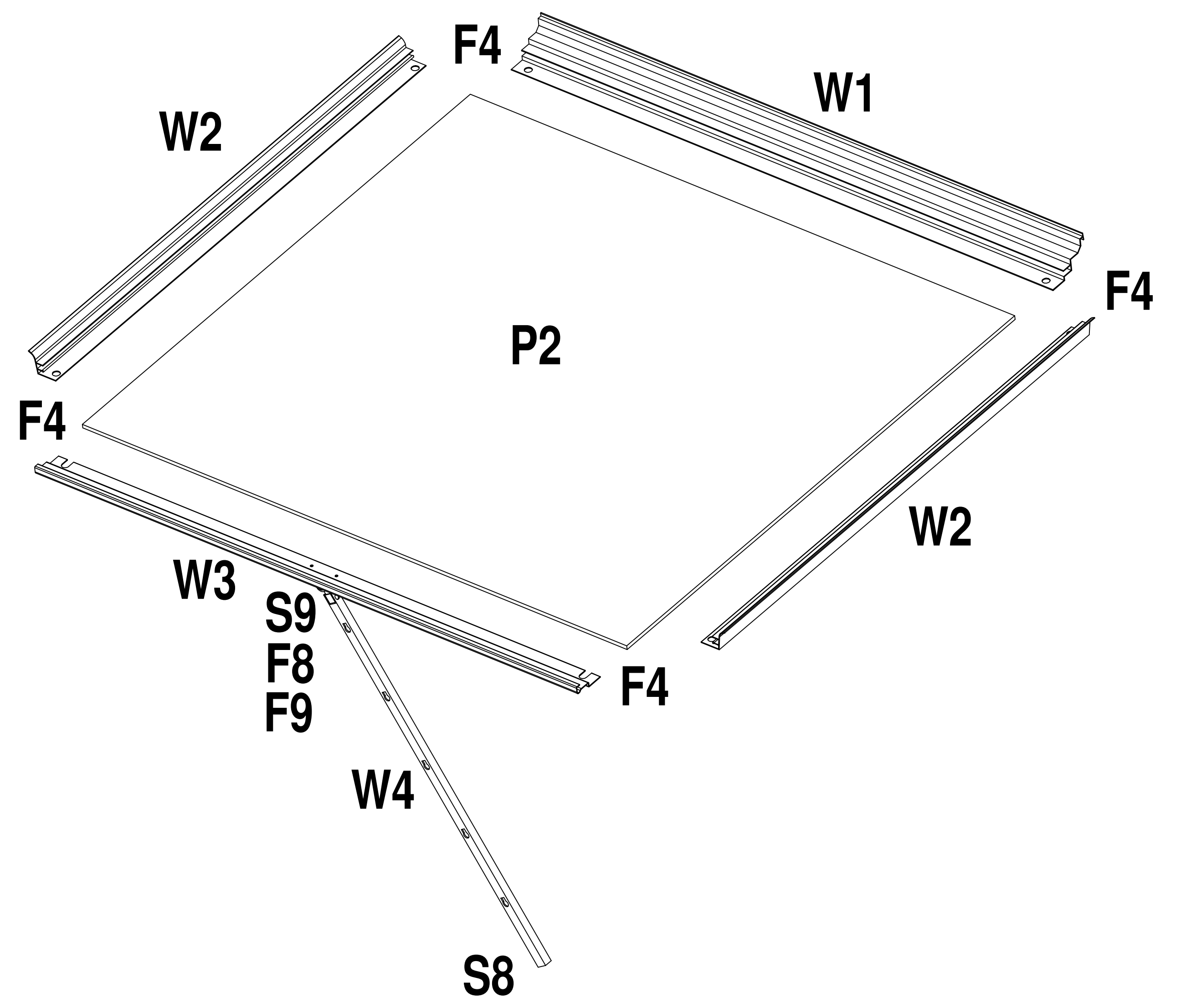
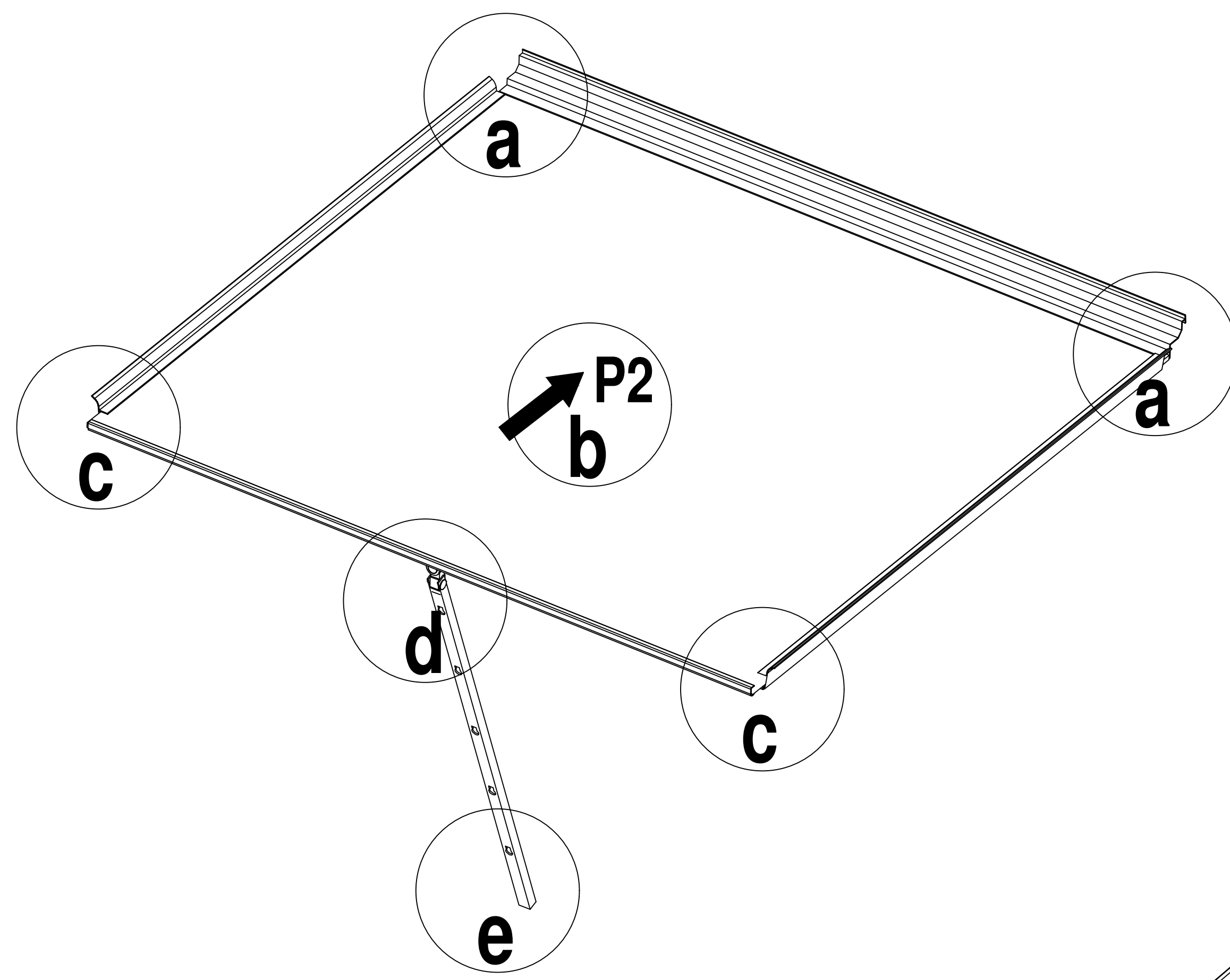

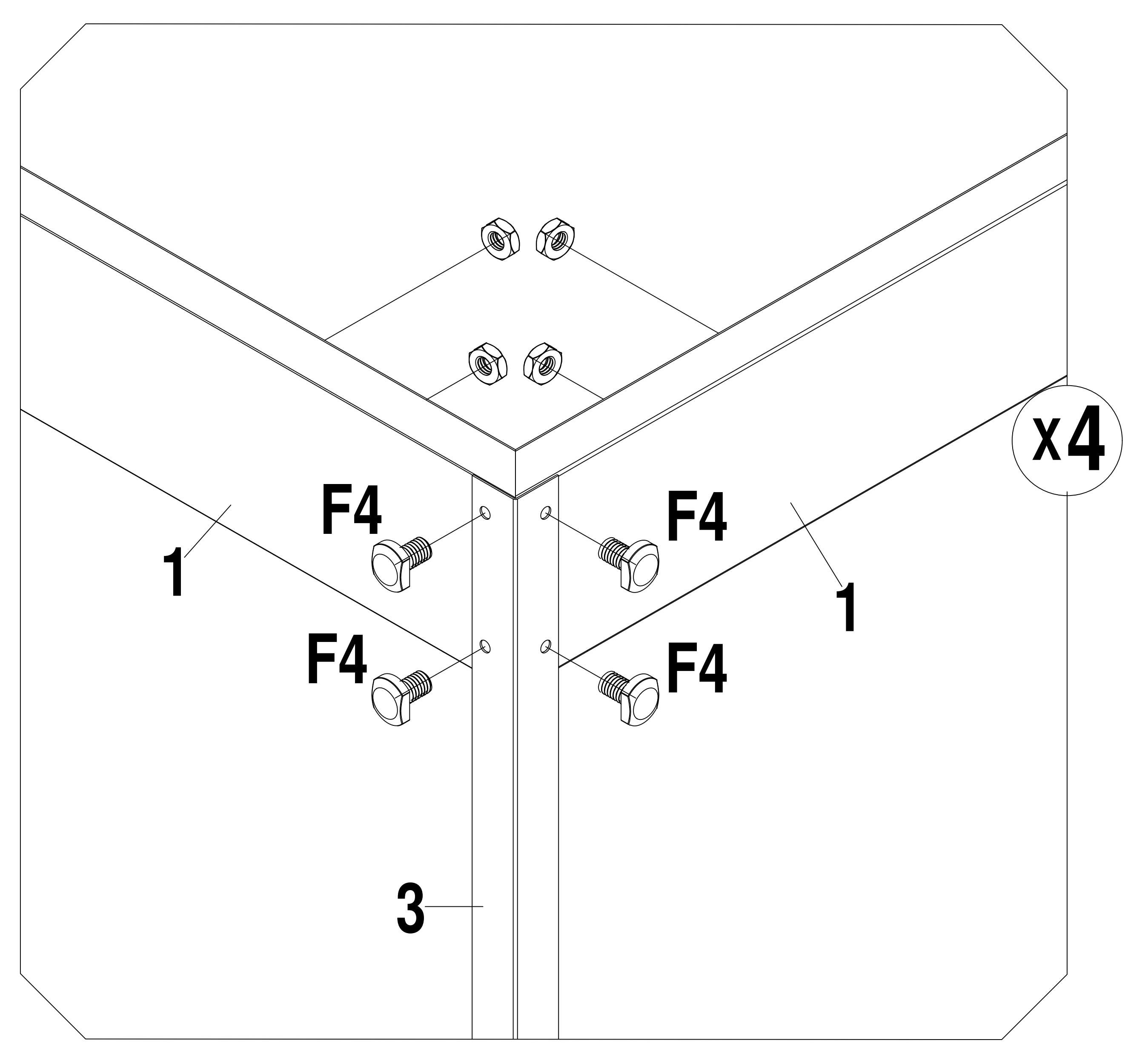
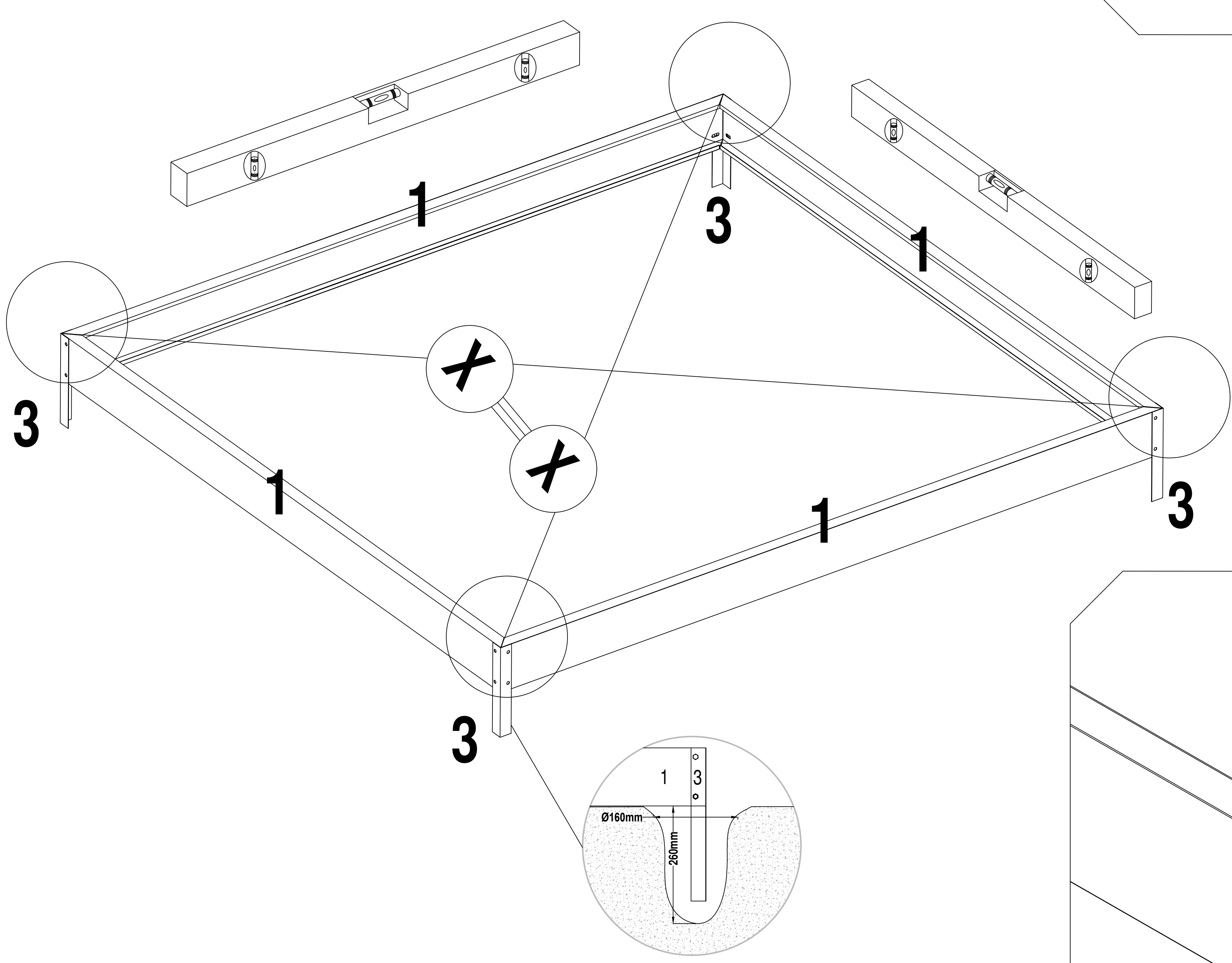
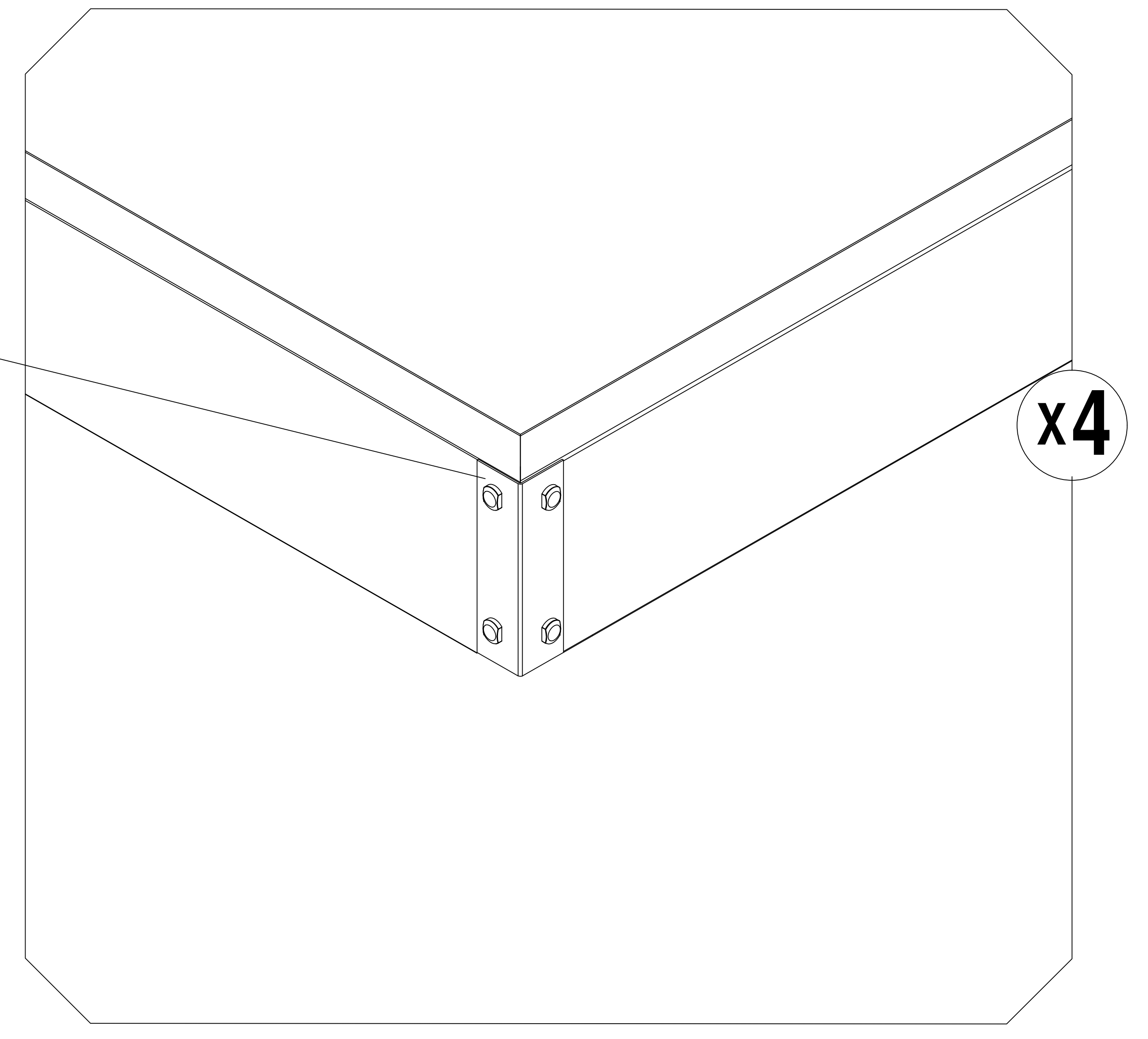
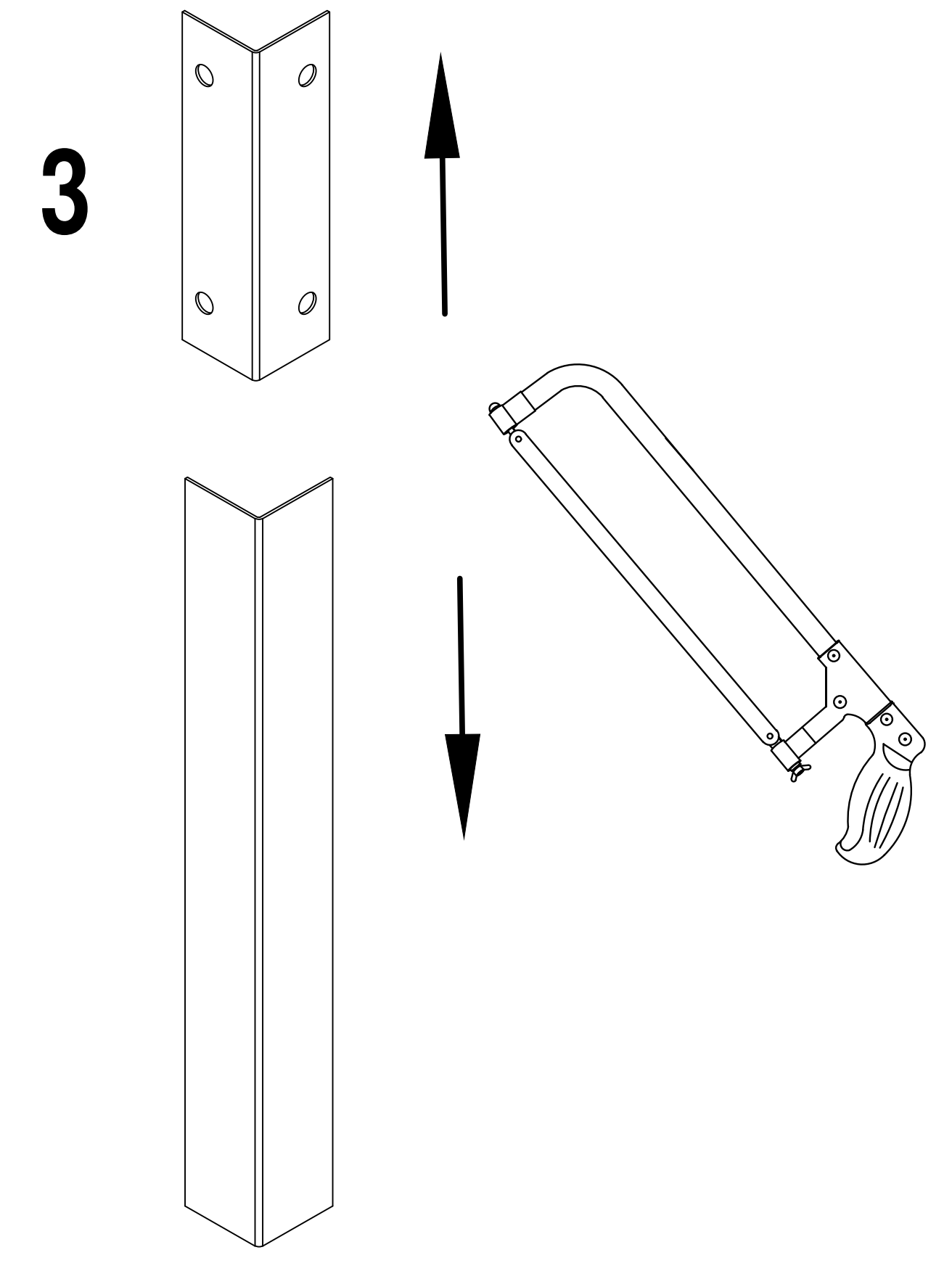
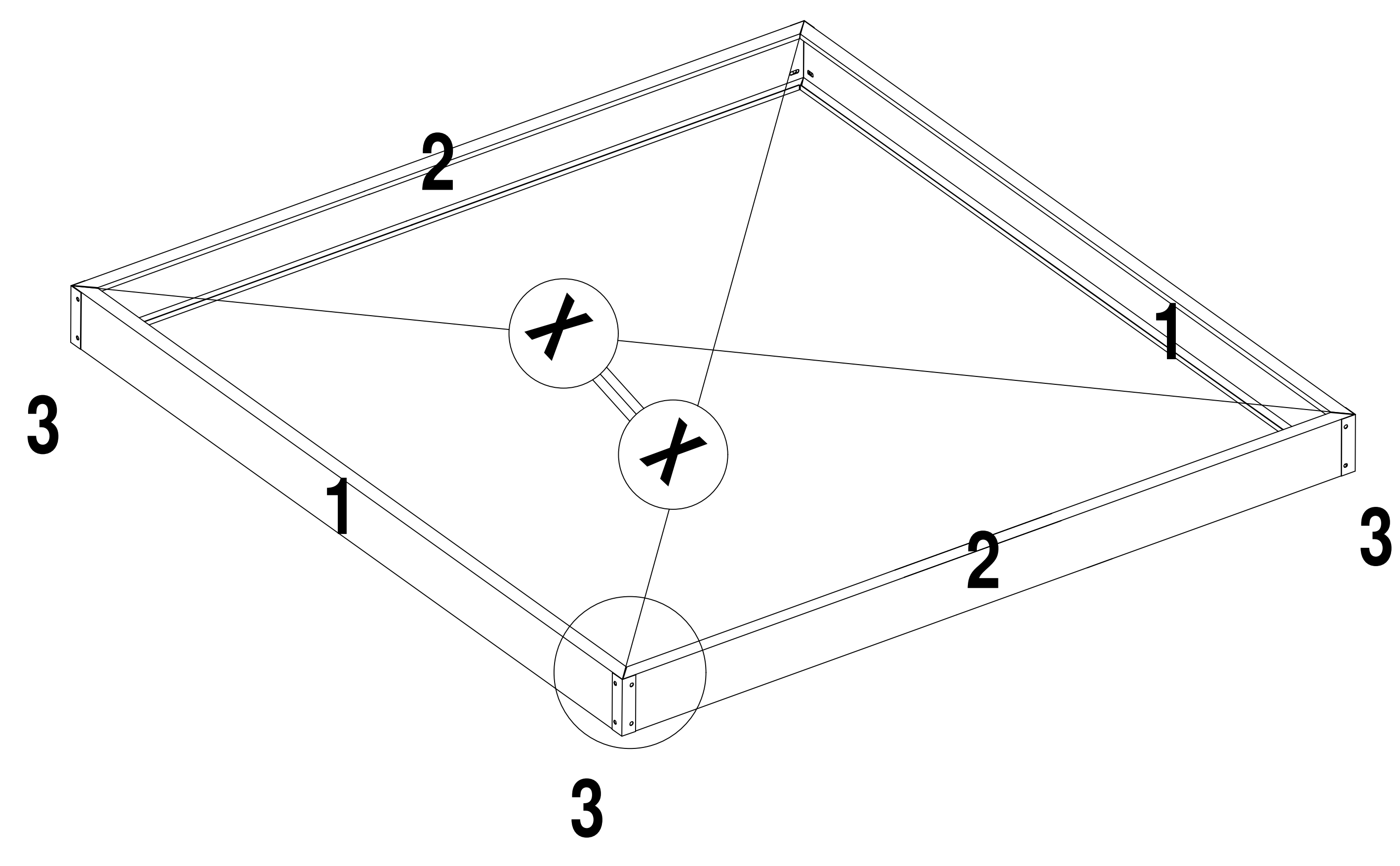
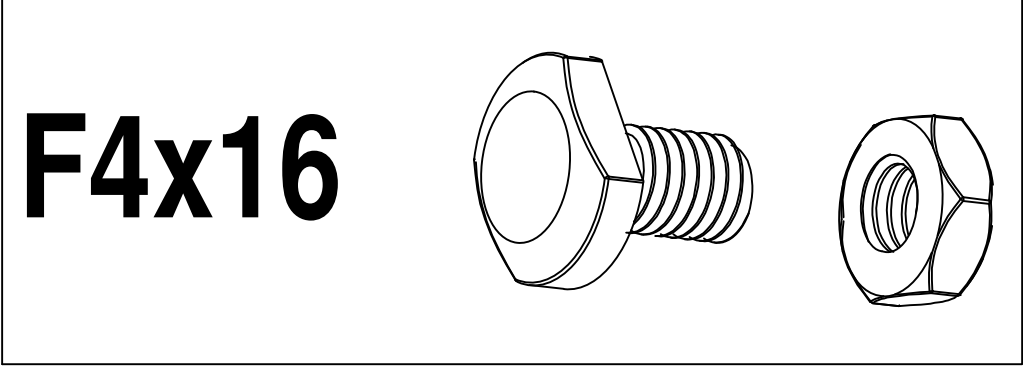
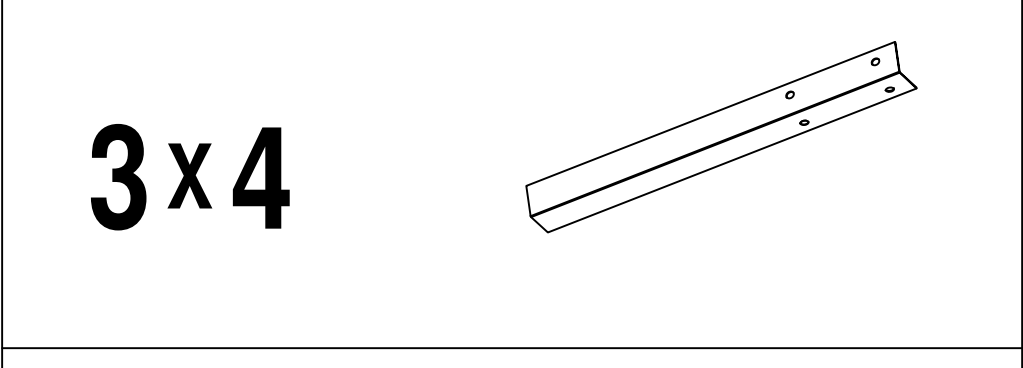
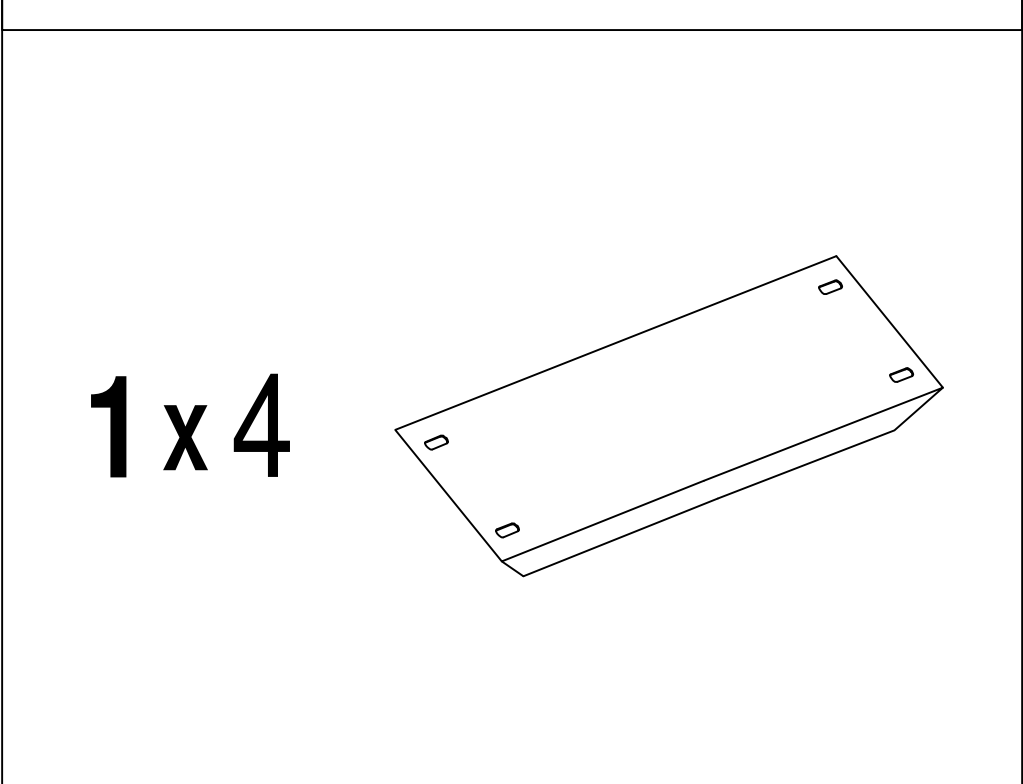
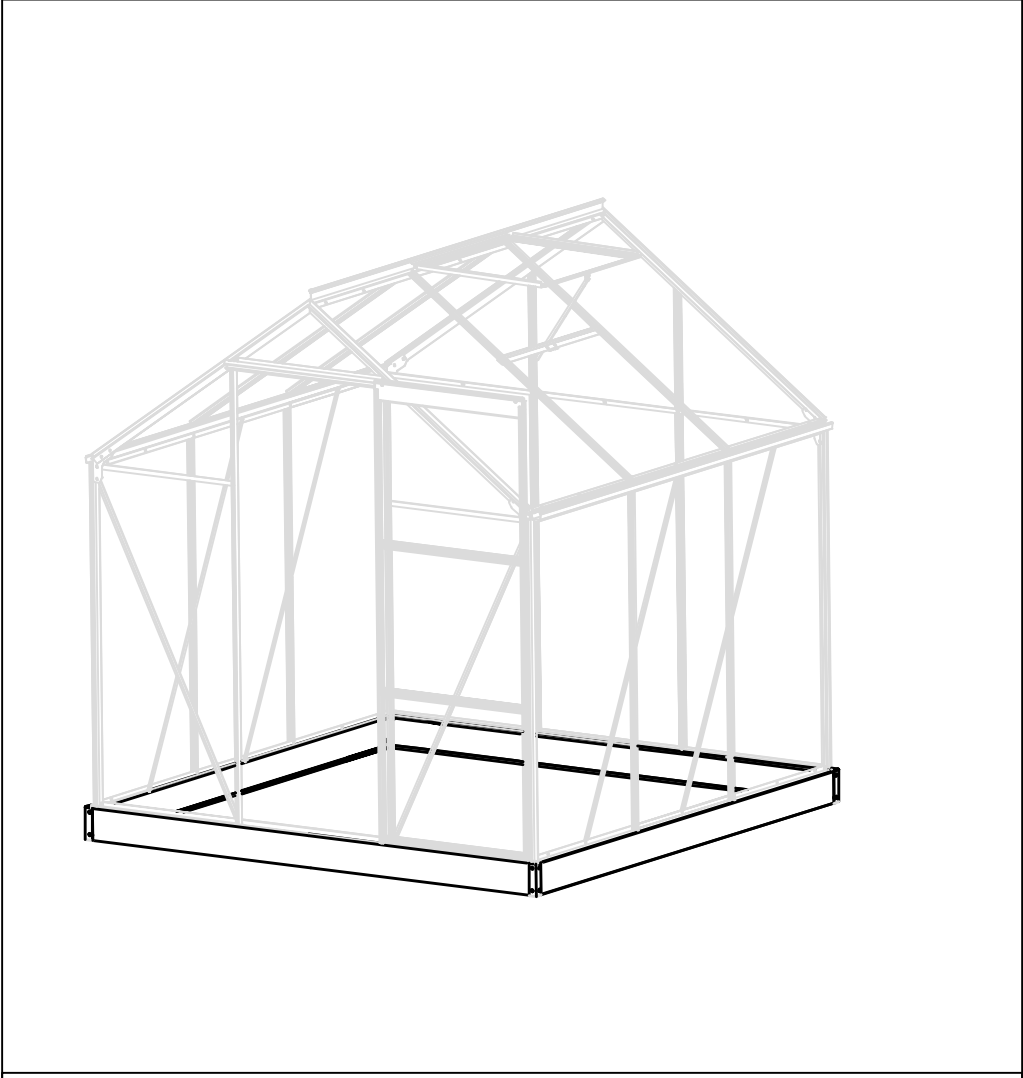

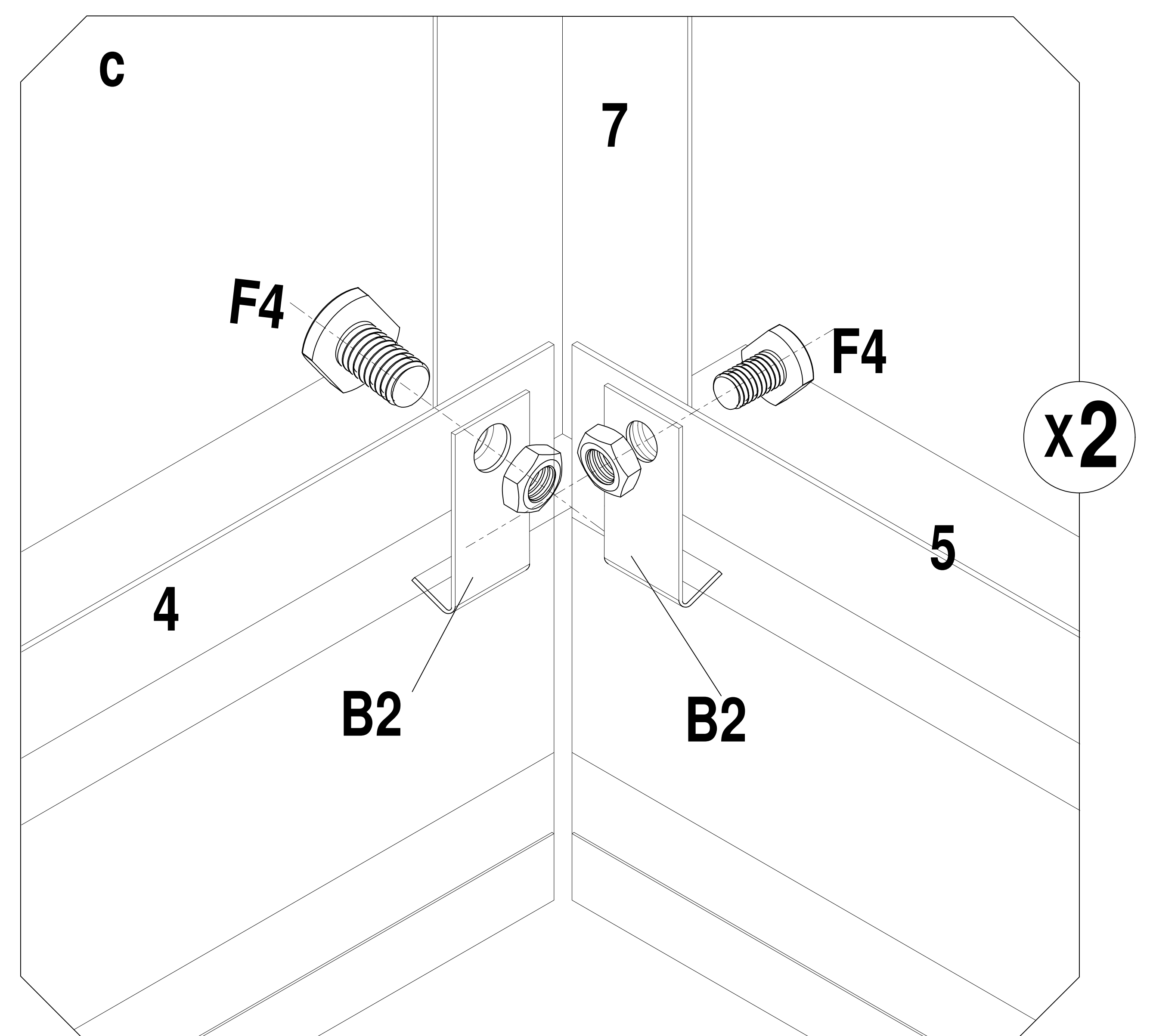
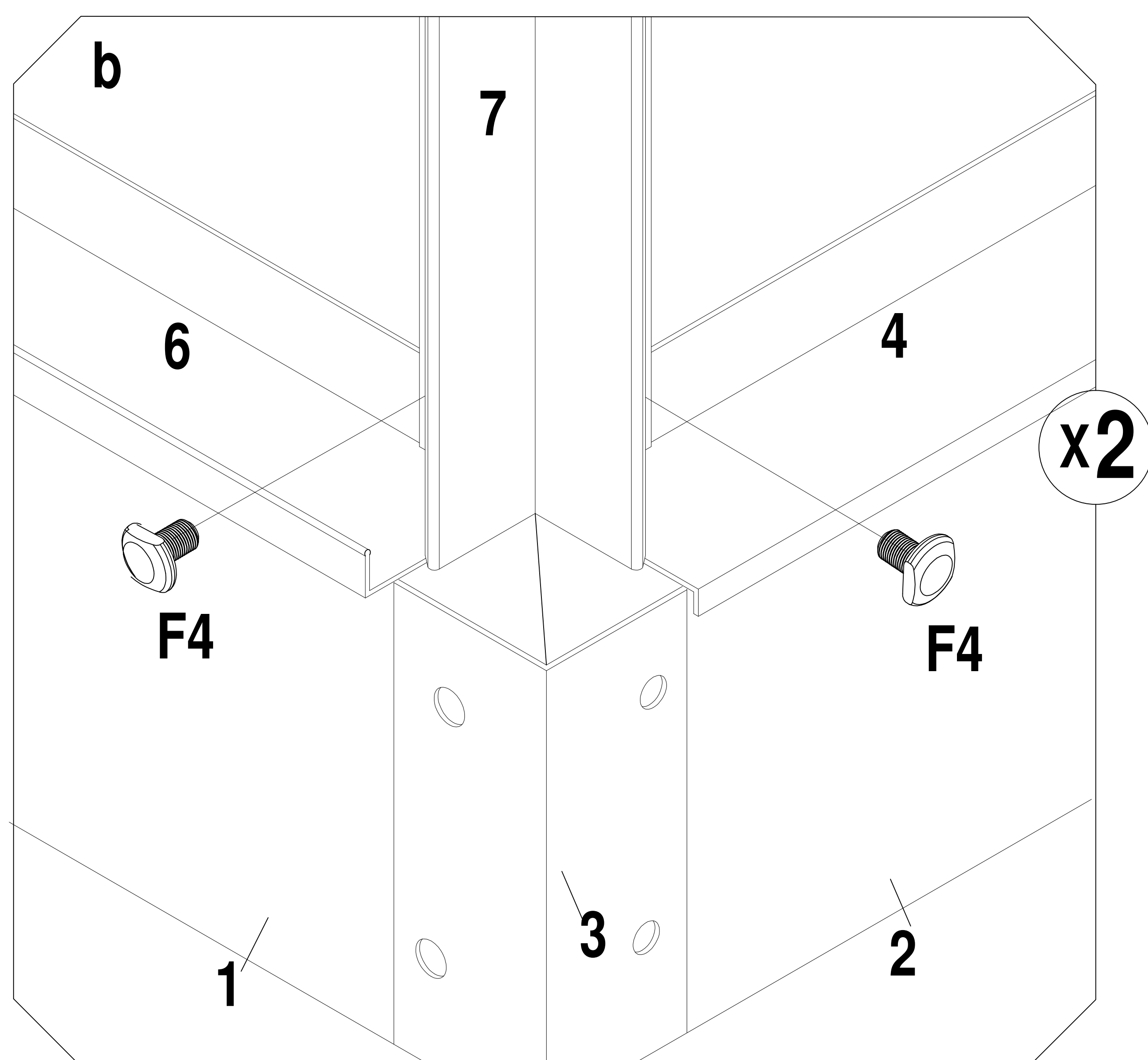
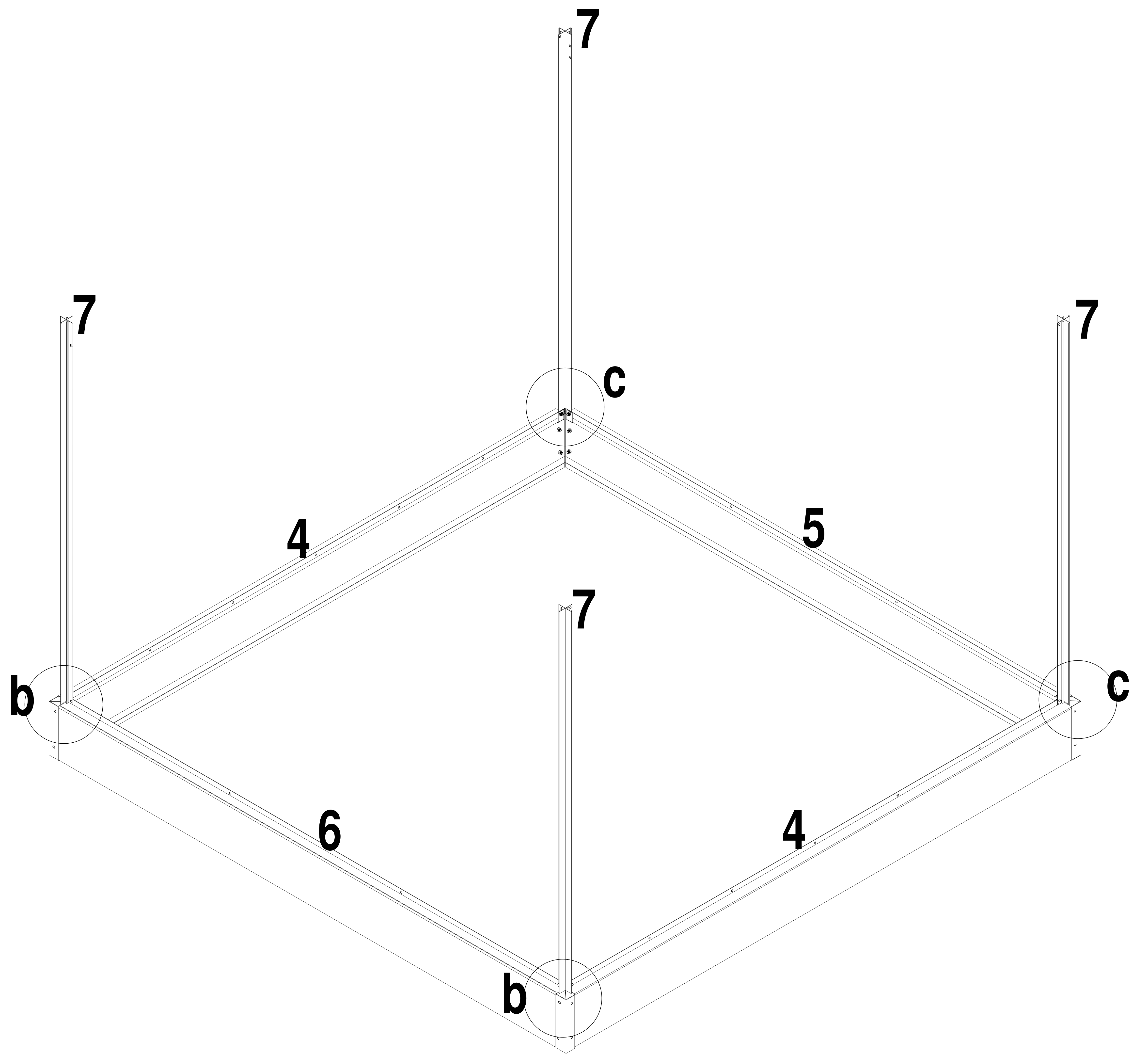
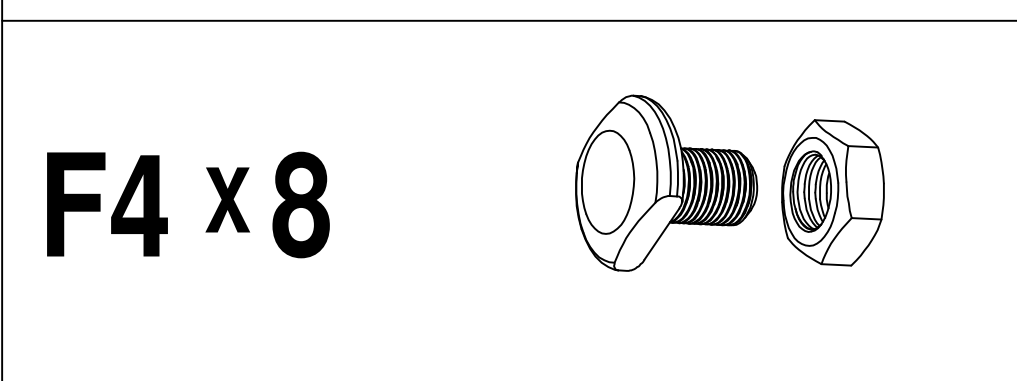
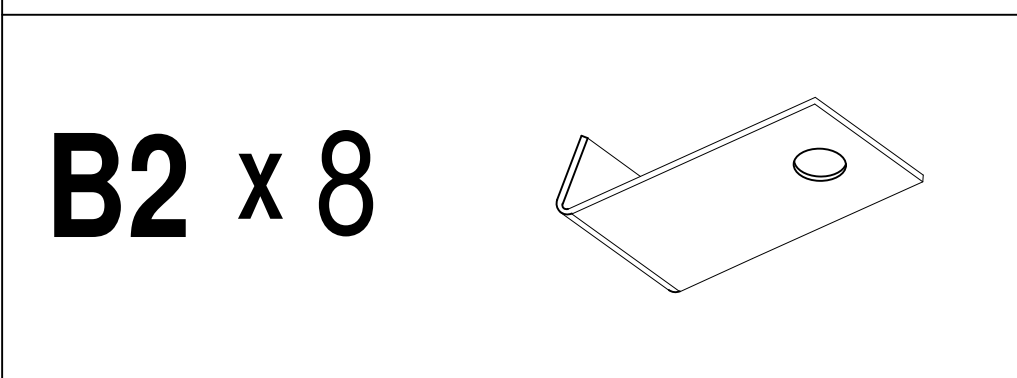
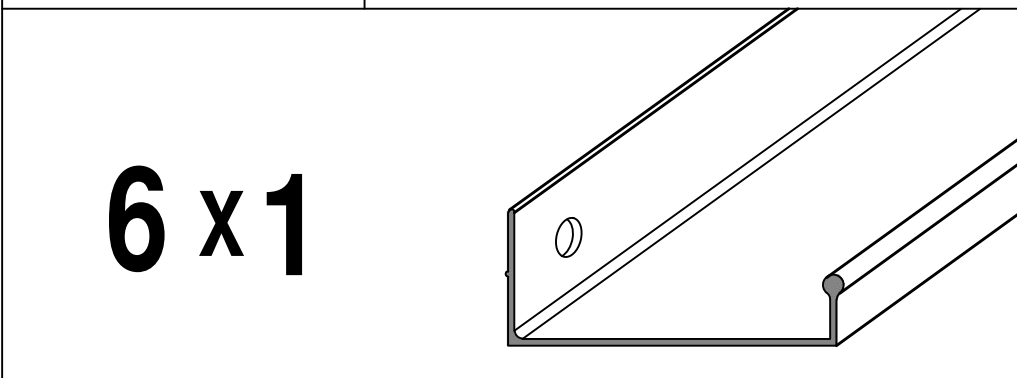
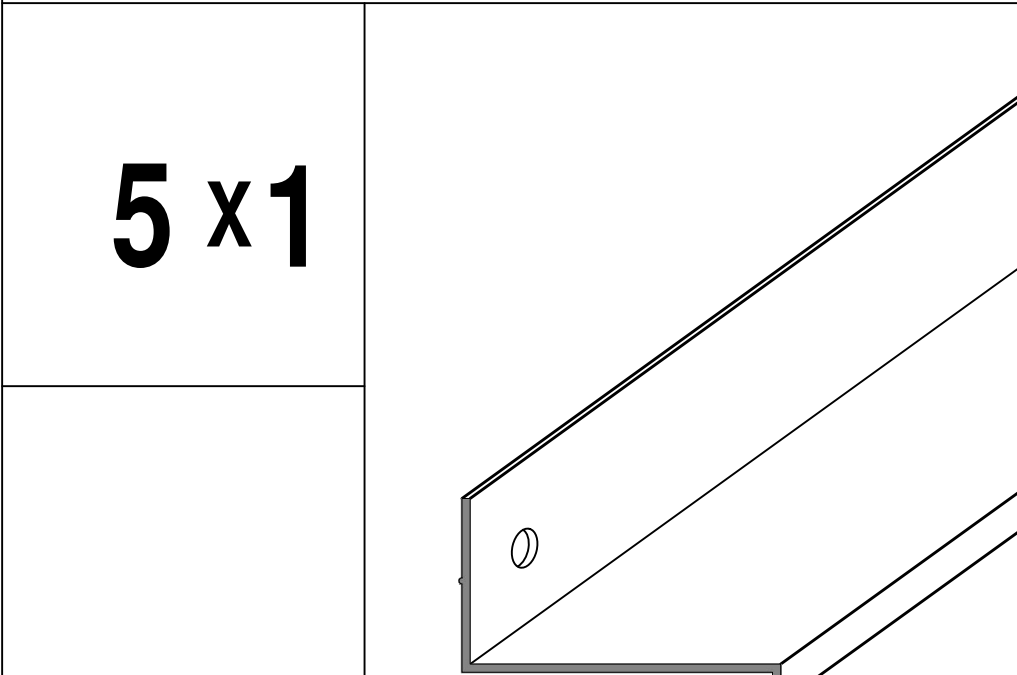
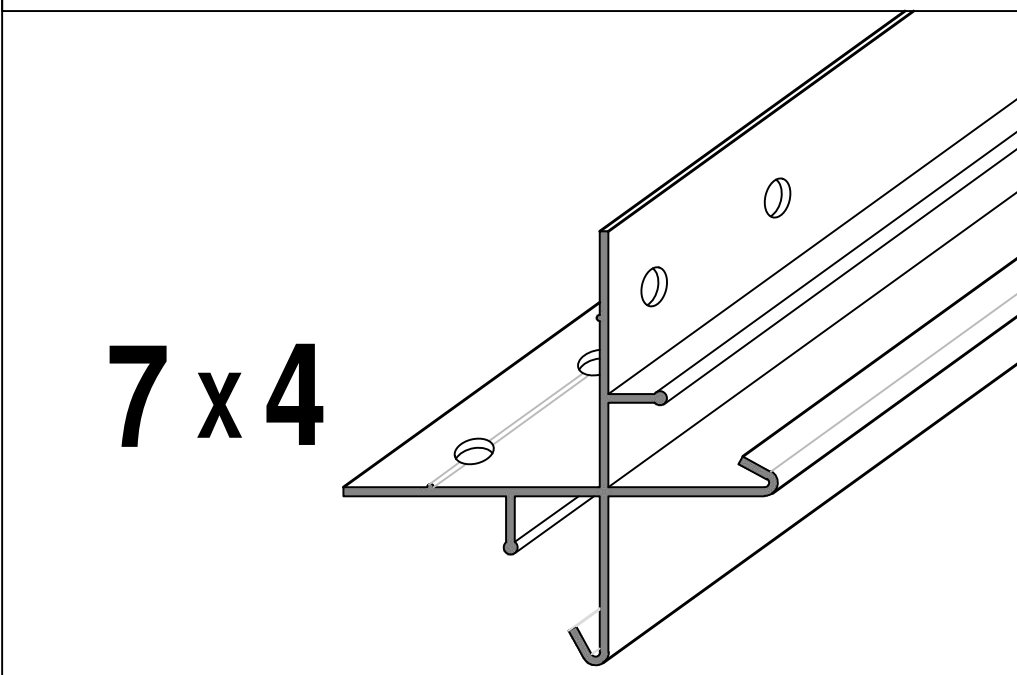
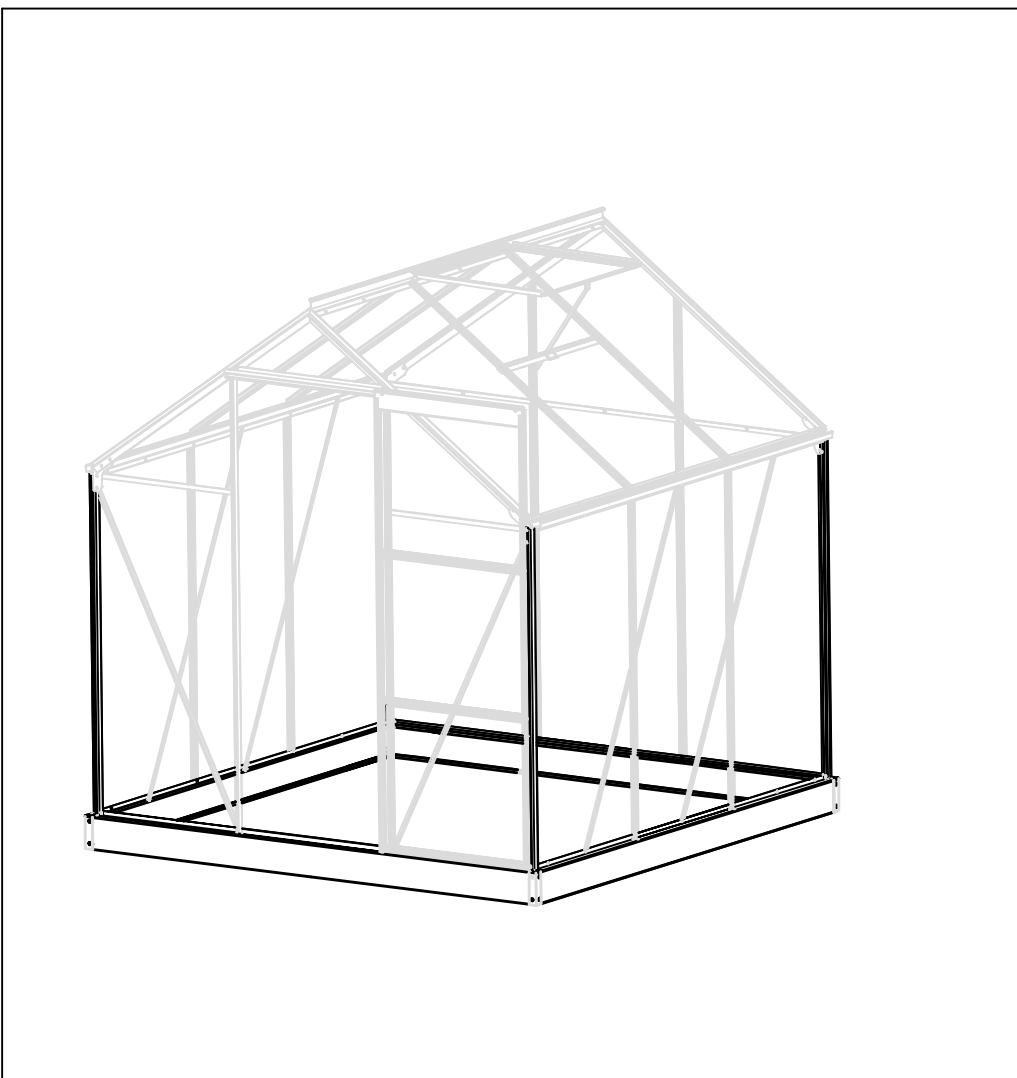

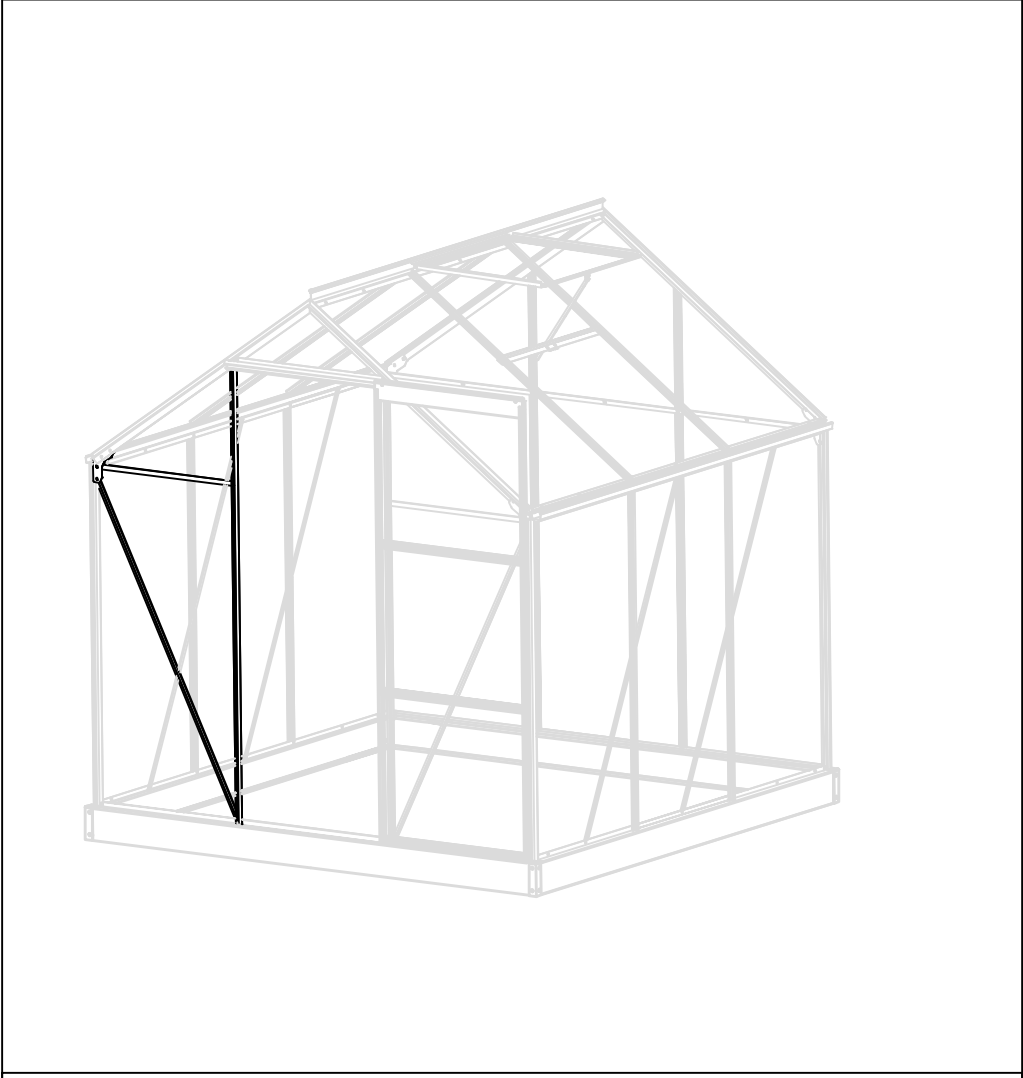

9L x1	
12 x1	
23 x1	
B5 x1	
B2 x1	
F4 x4	

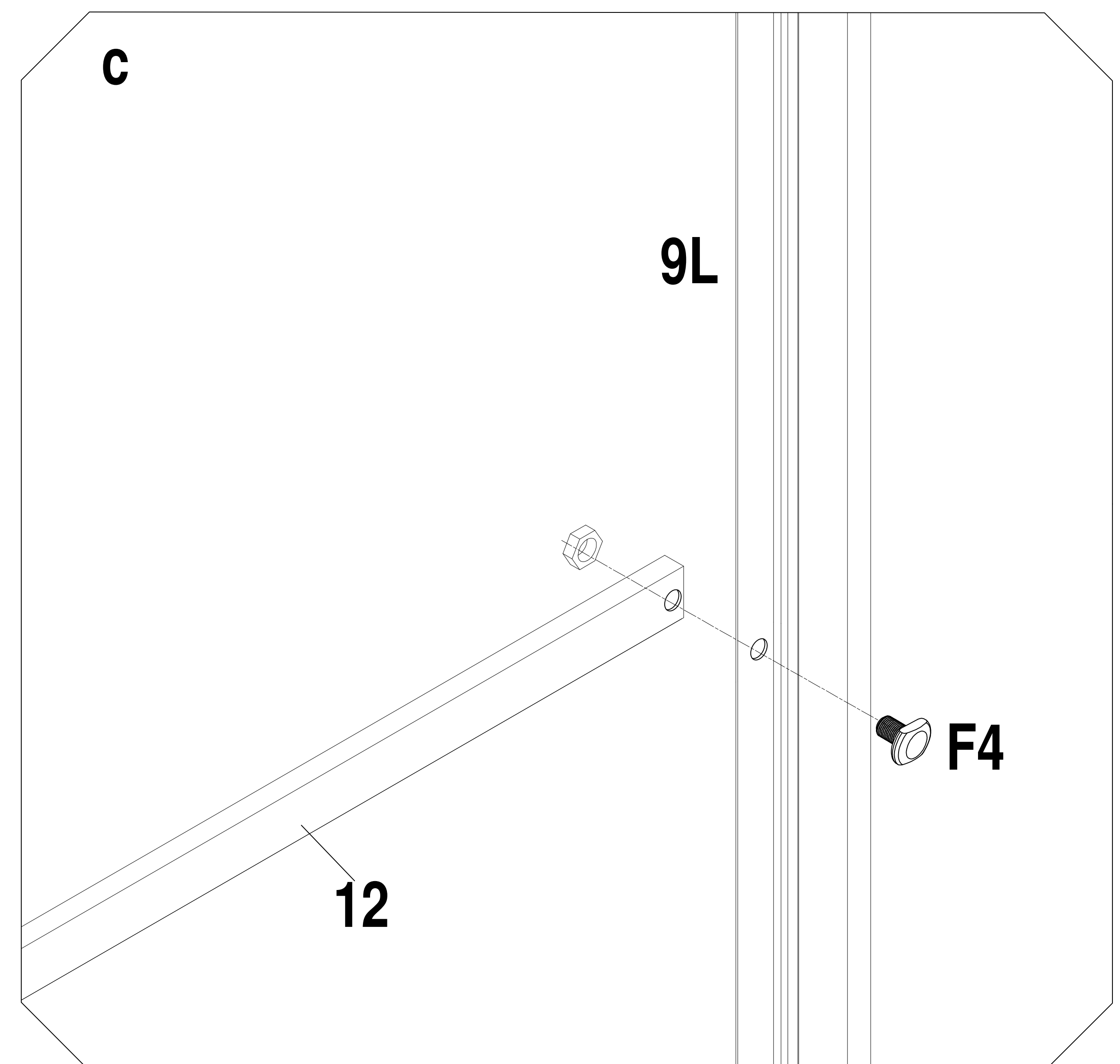
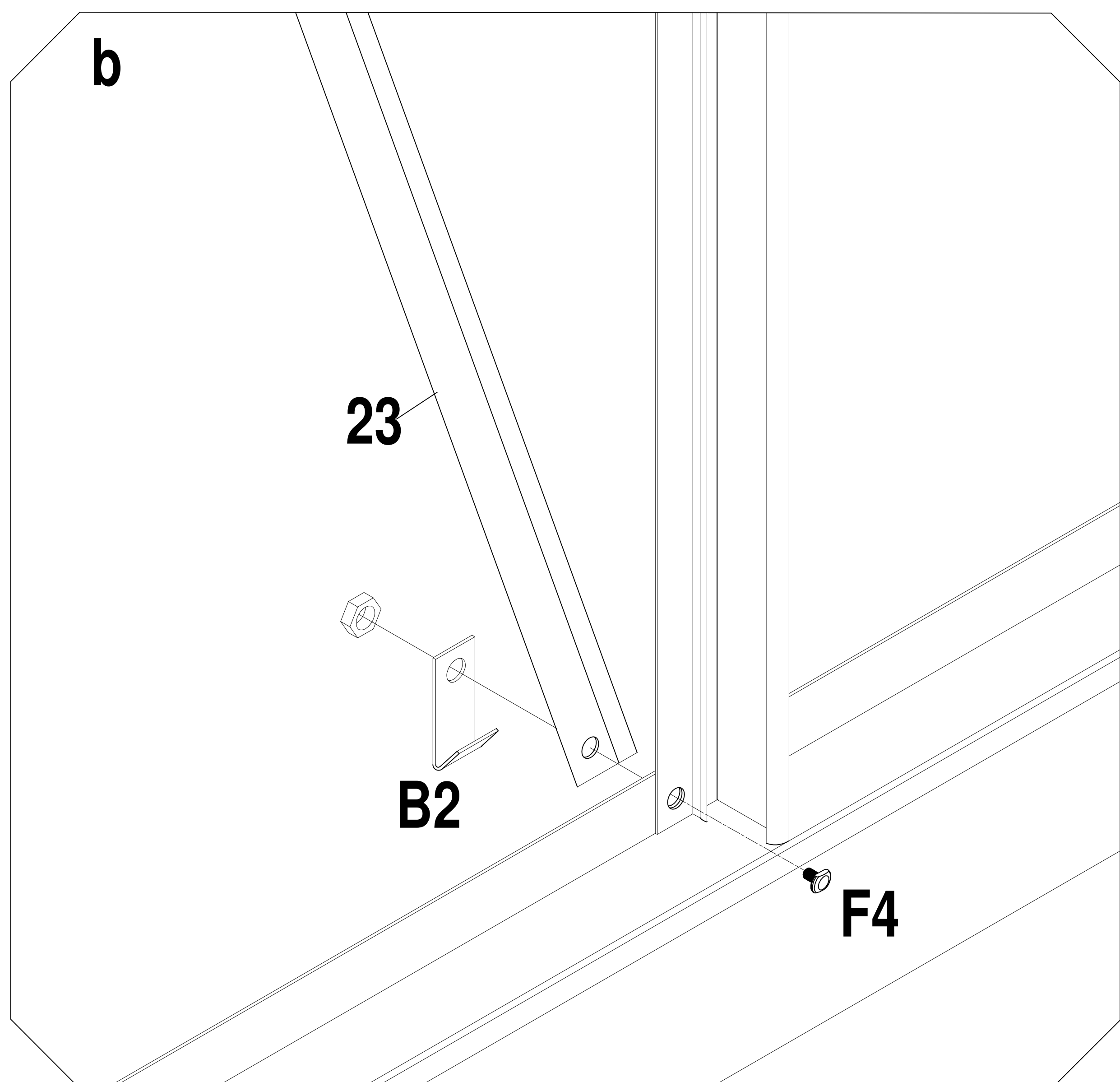
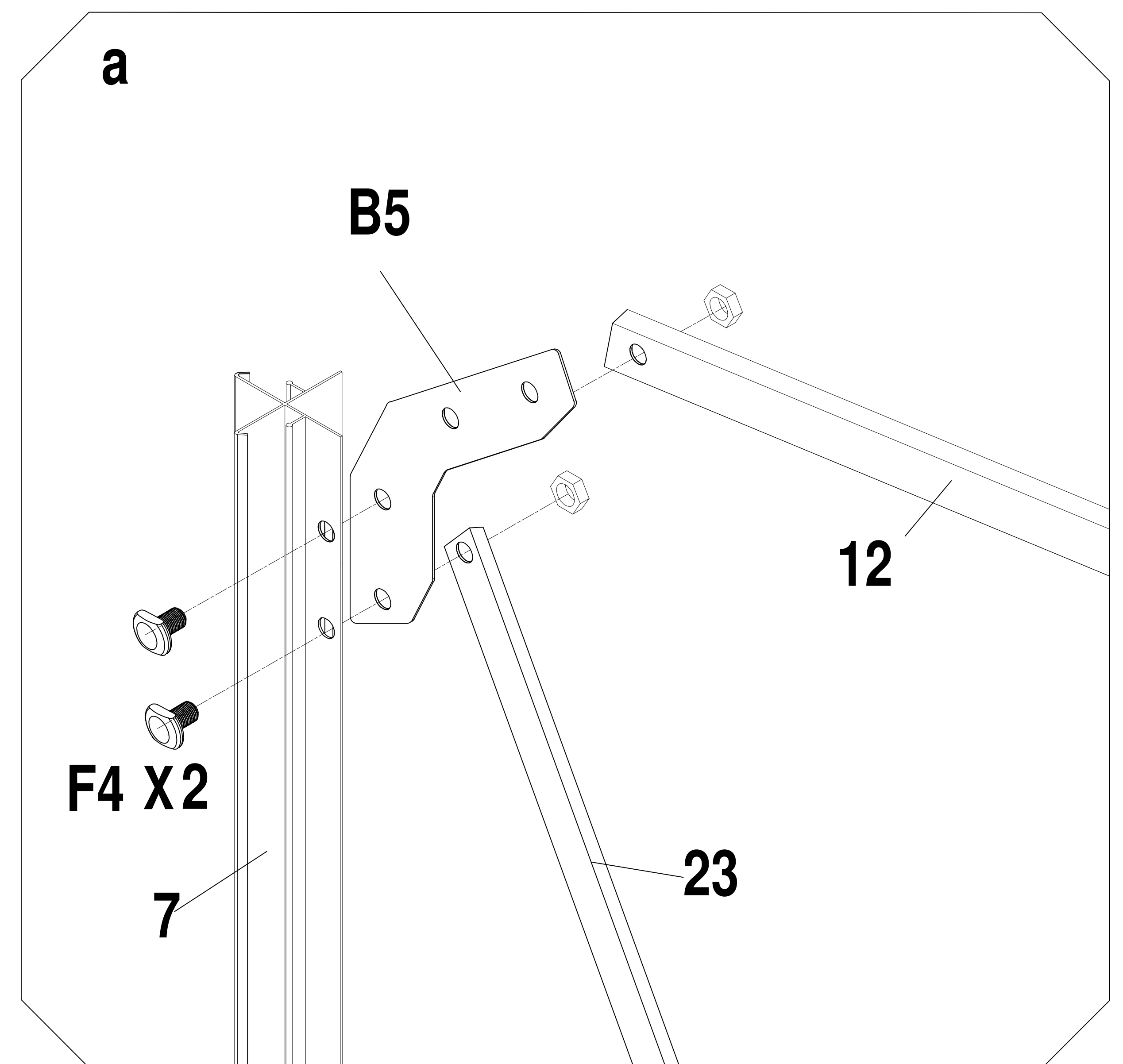
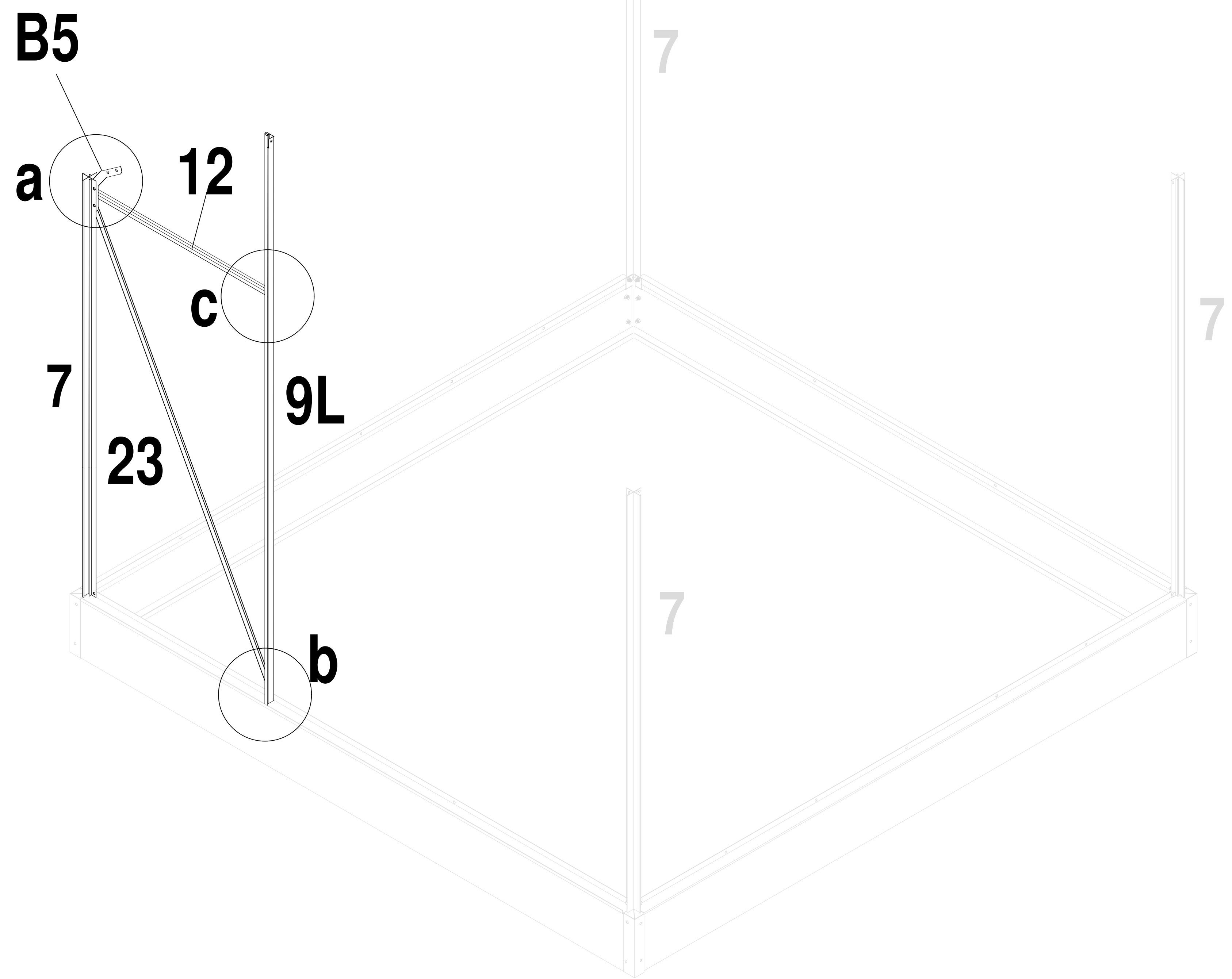

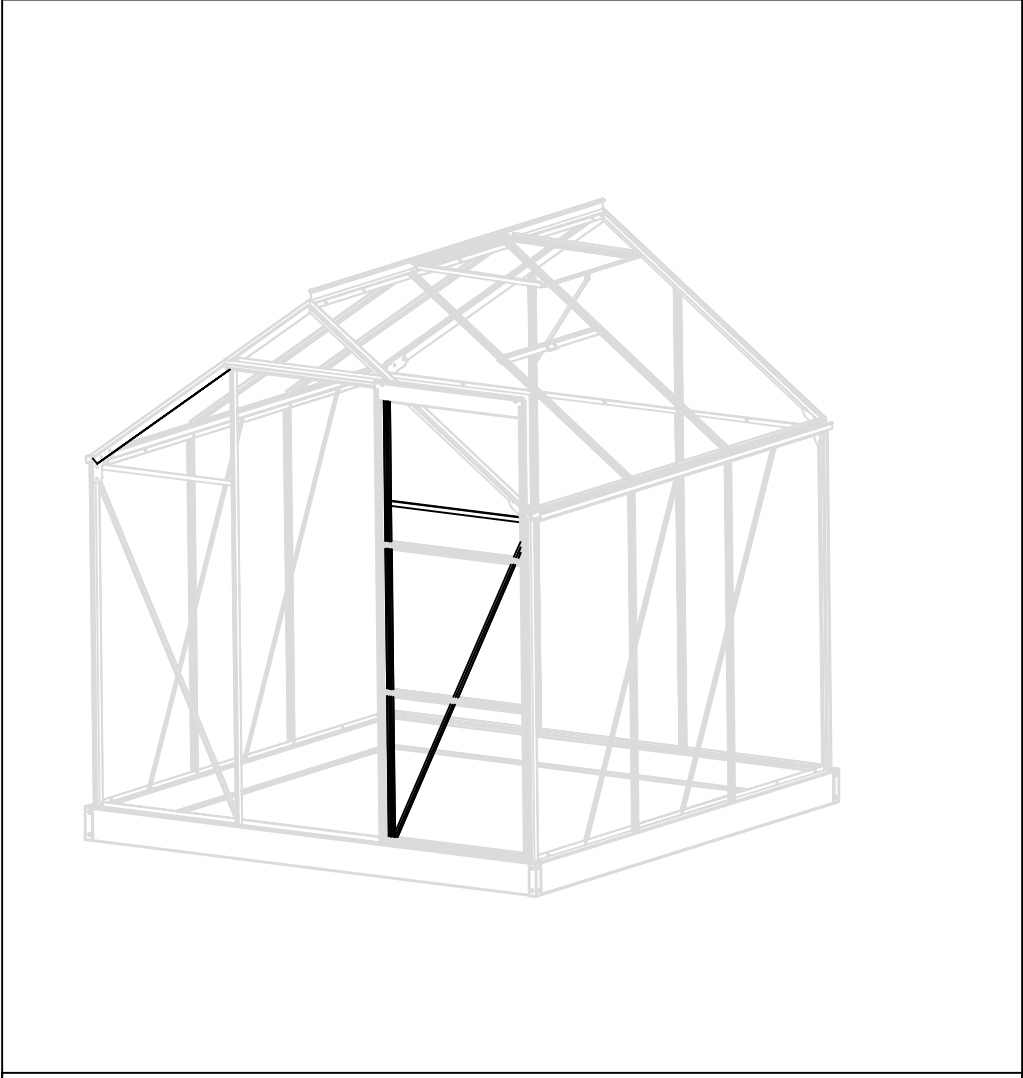

9R x1	
12 x1	
23 x1	
B5 x1	
B2 x1	
F4 x 4	

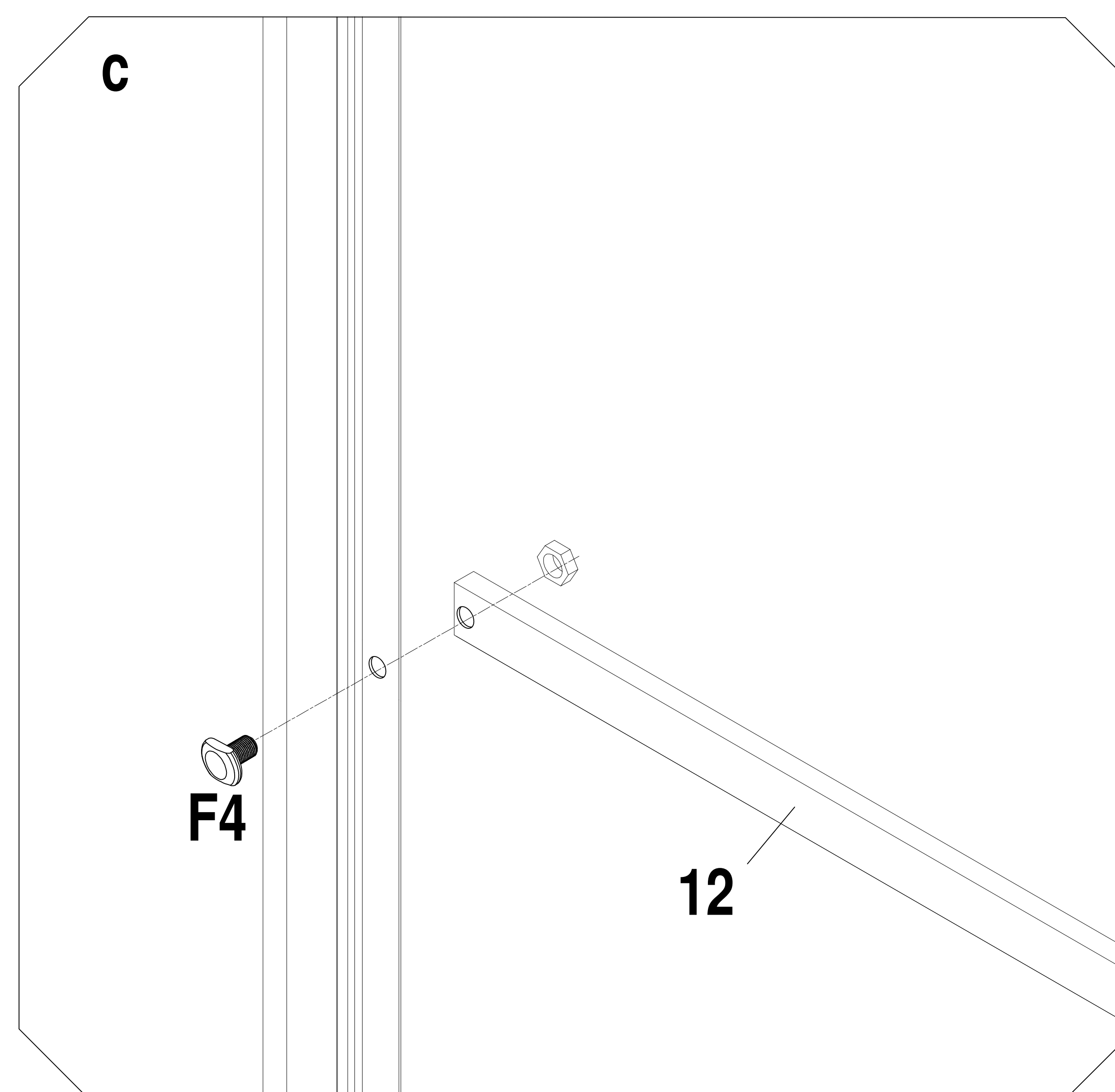
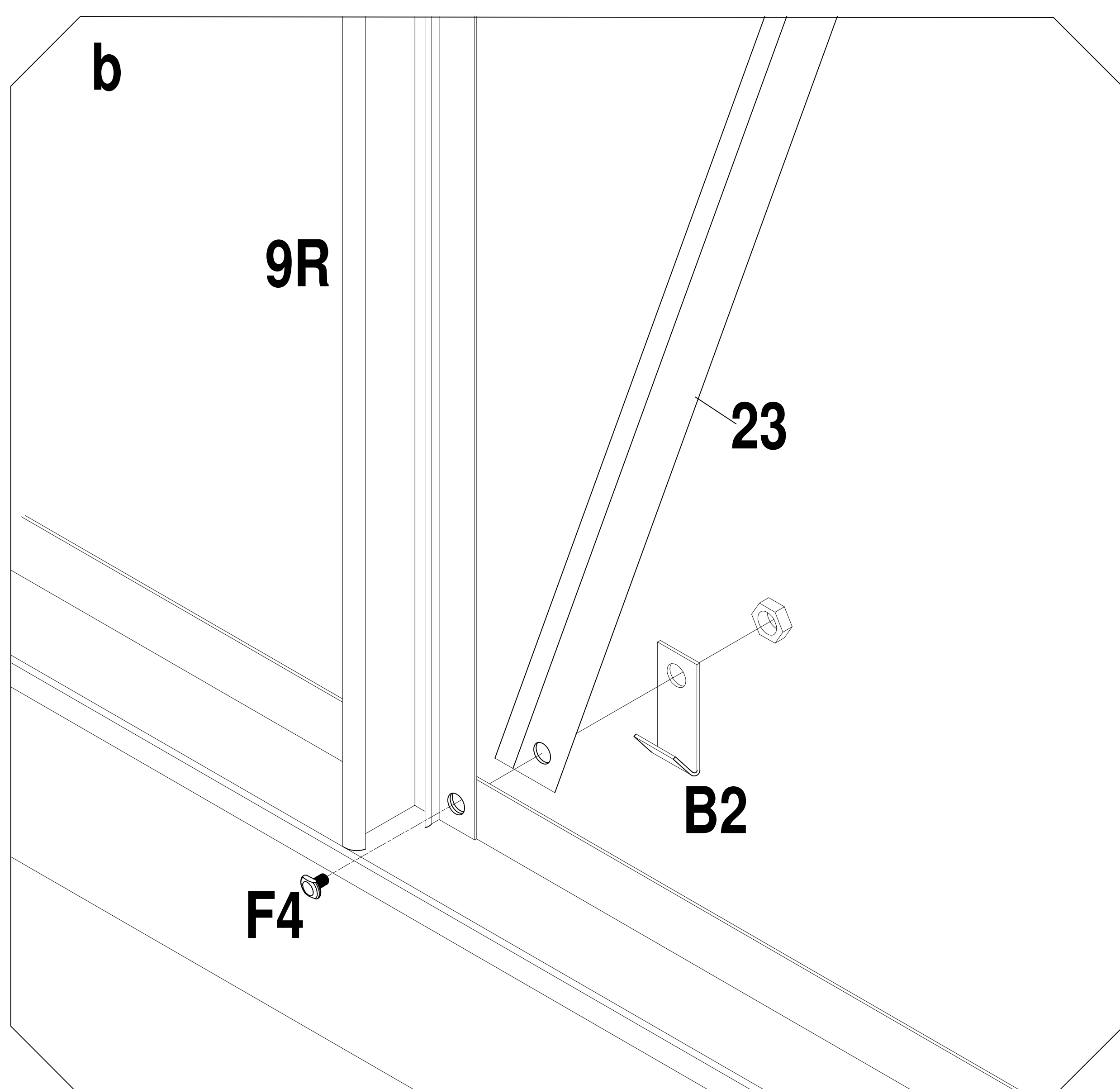
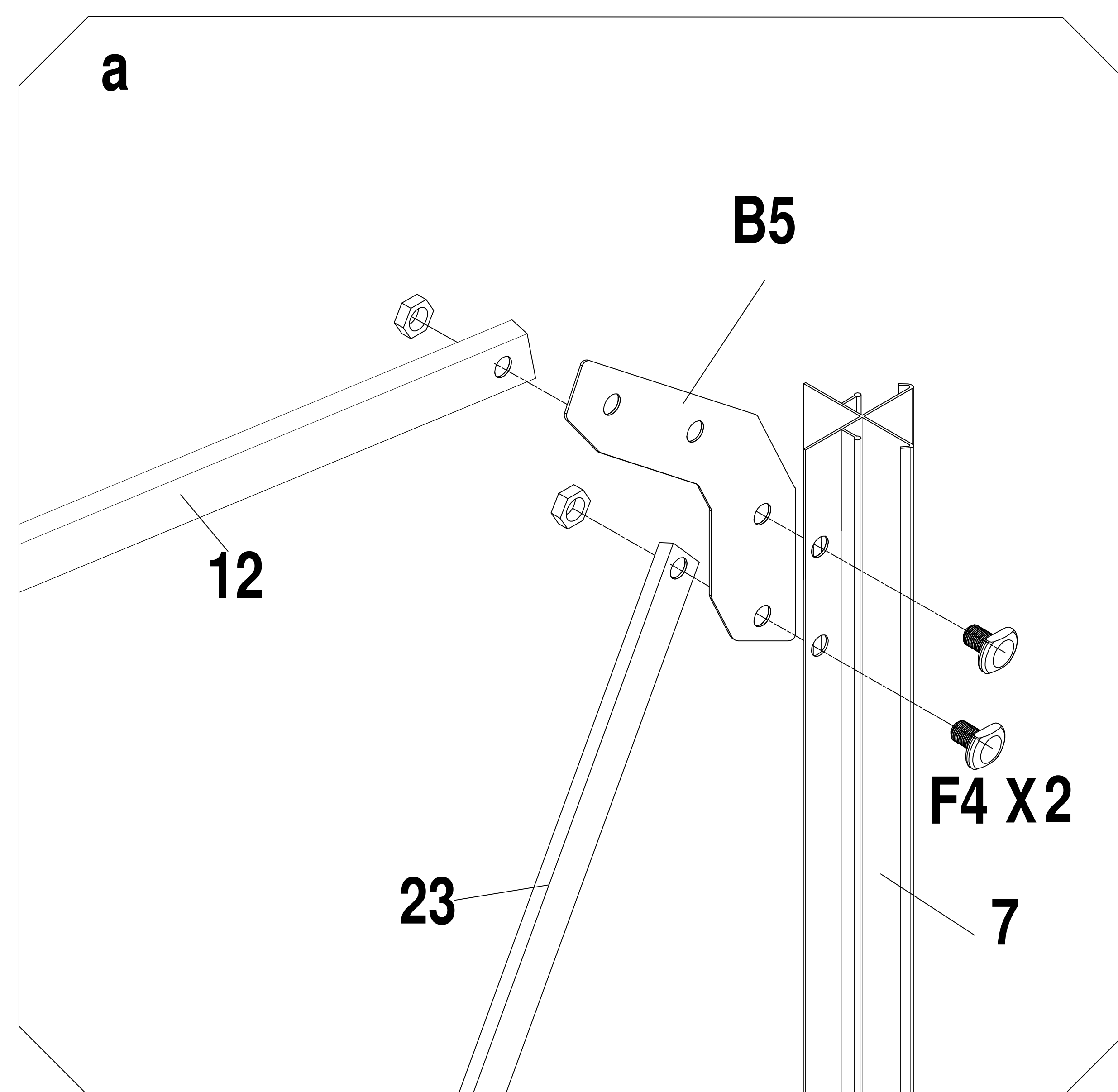
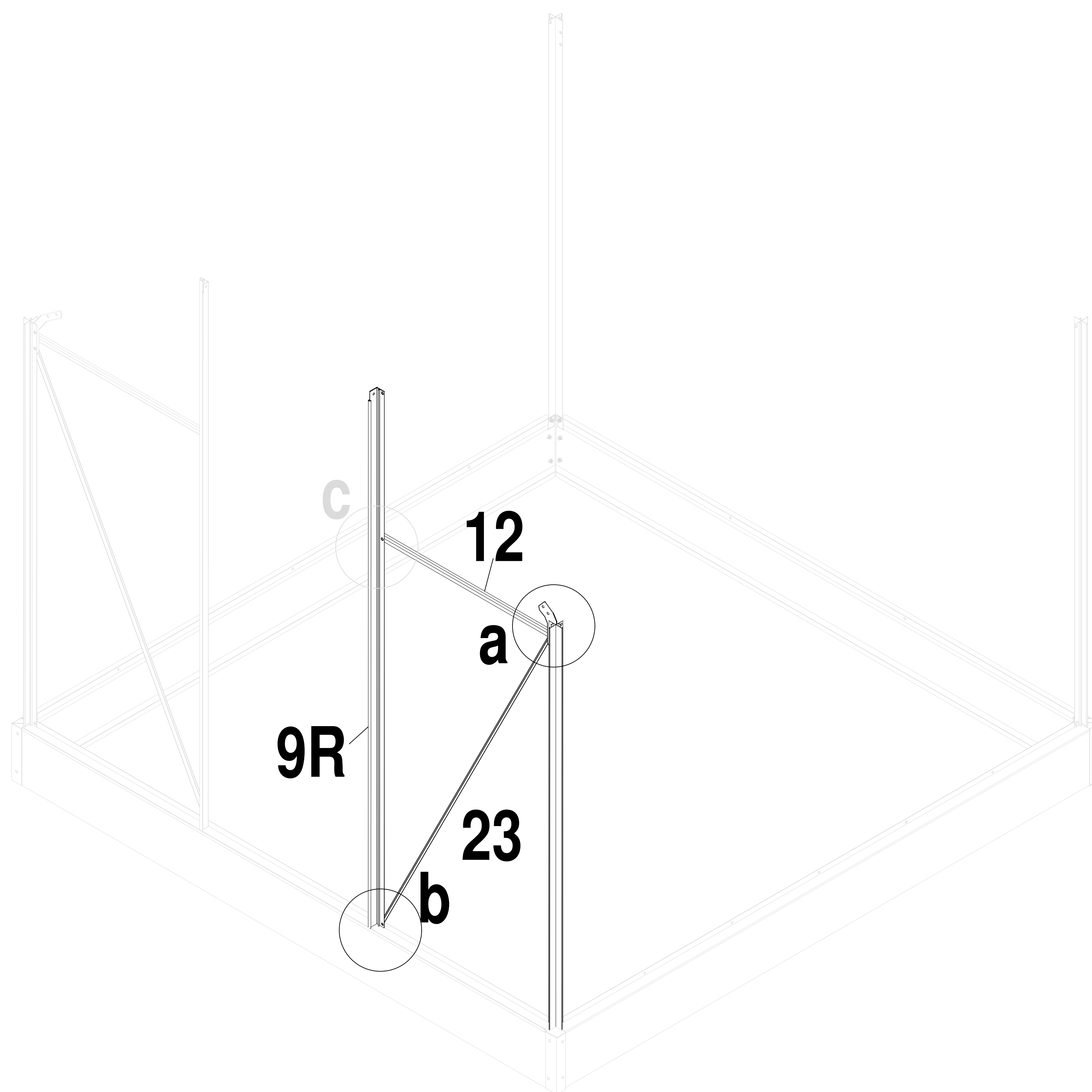

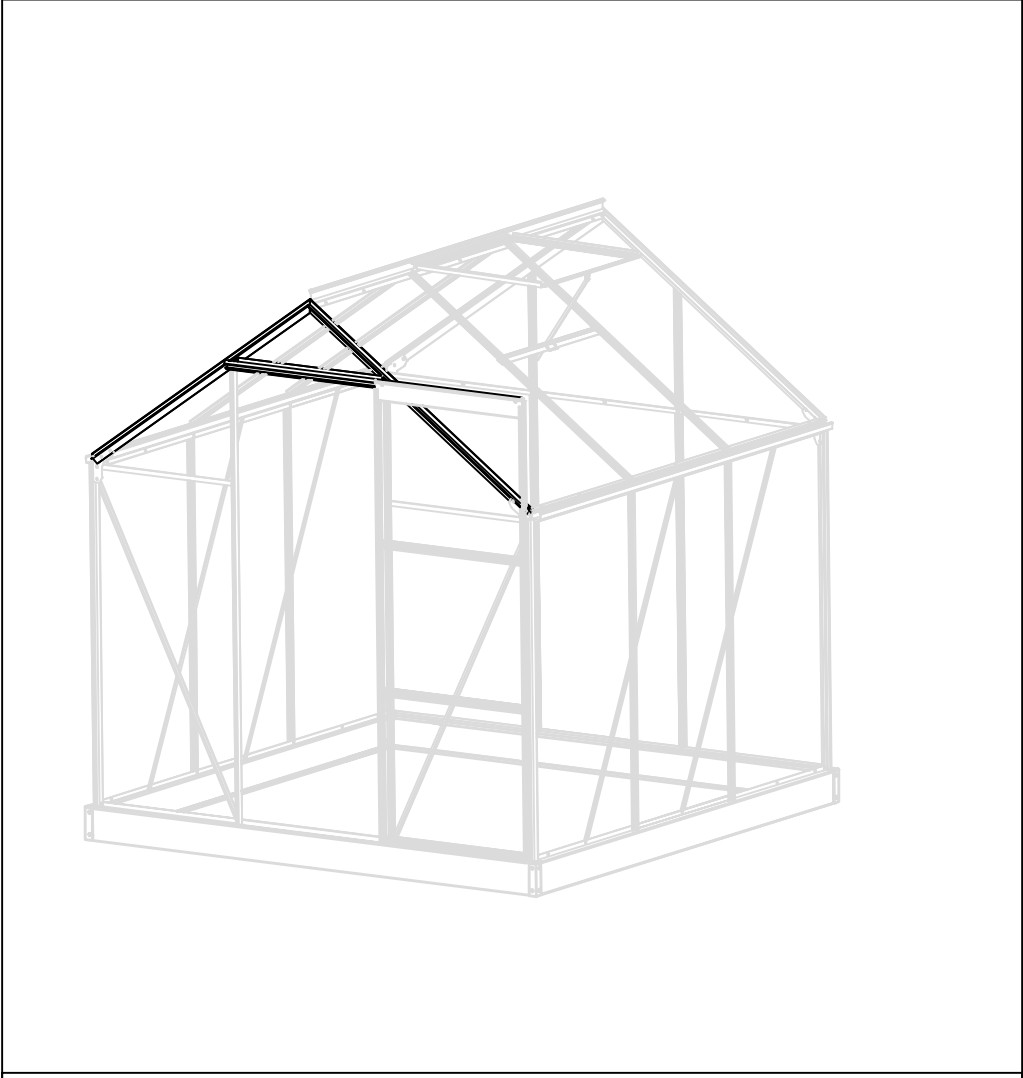

16-1 x1	
16-2 x1	
13 x1	
F4 x8	

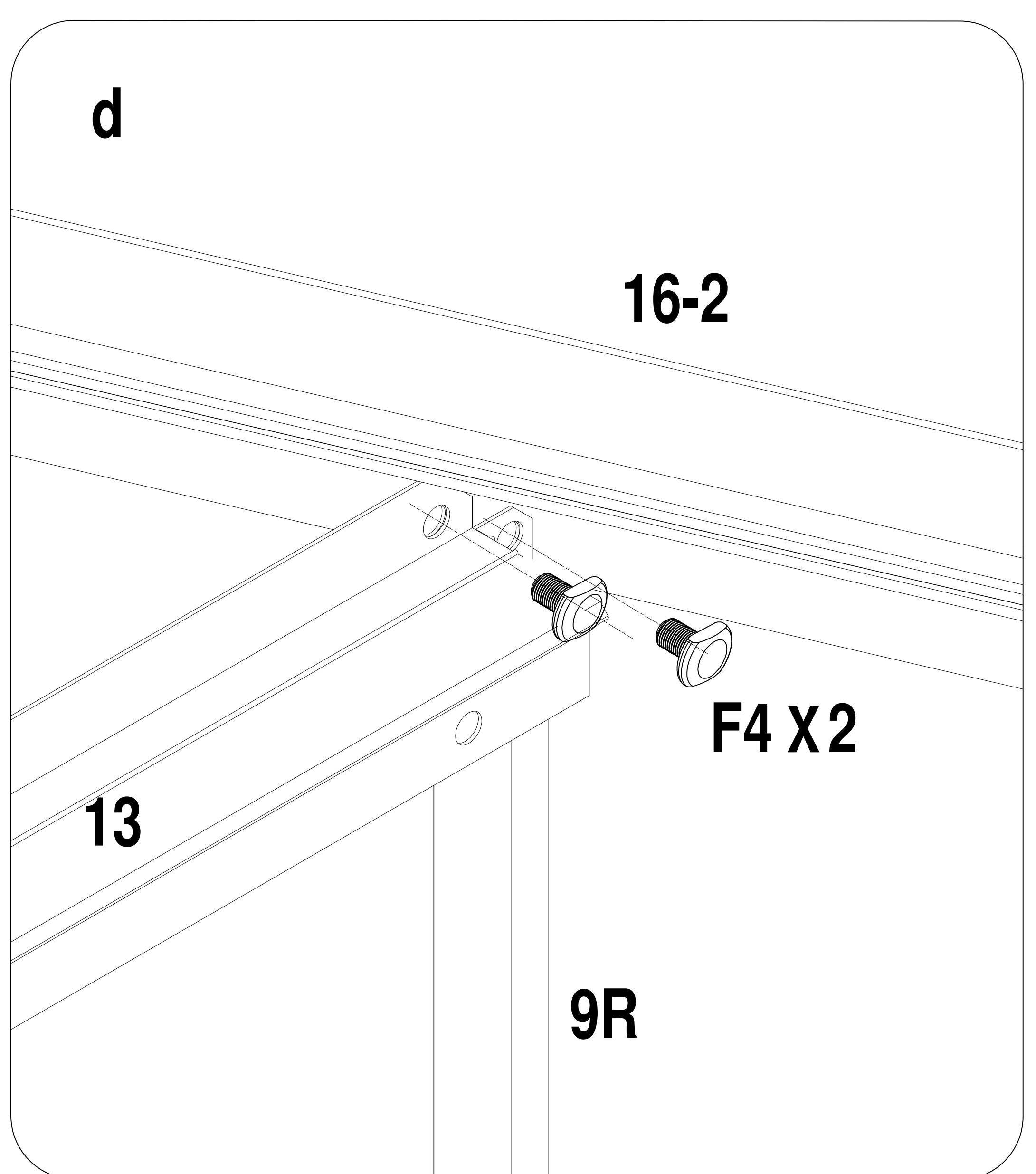
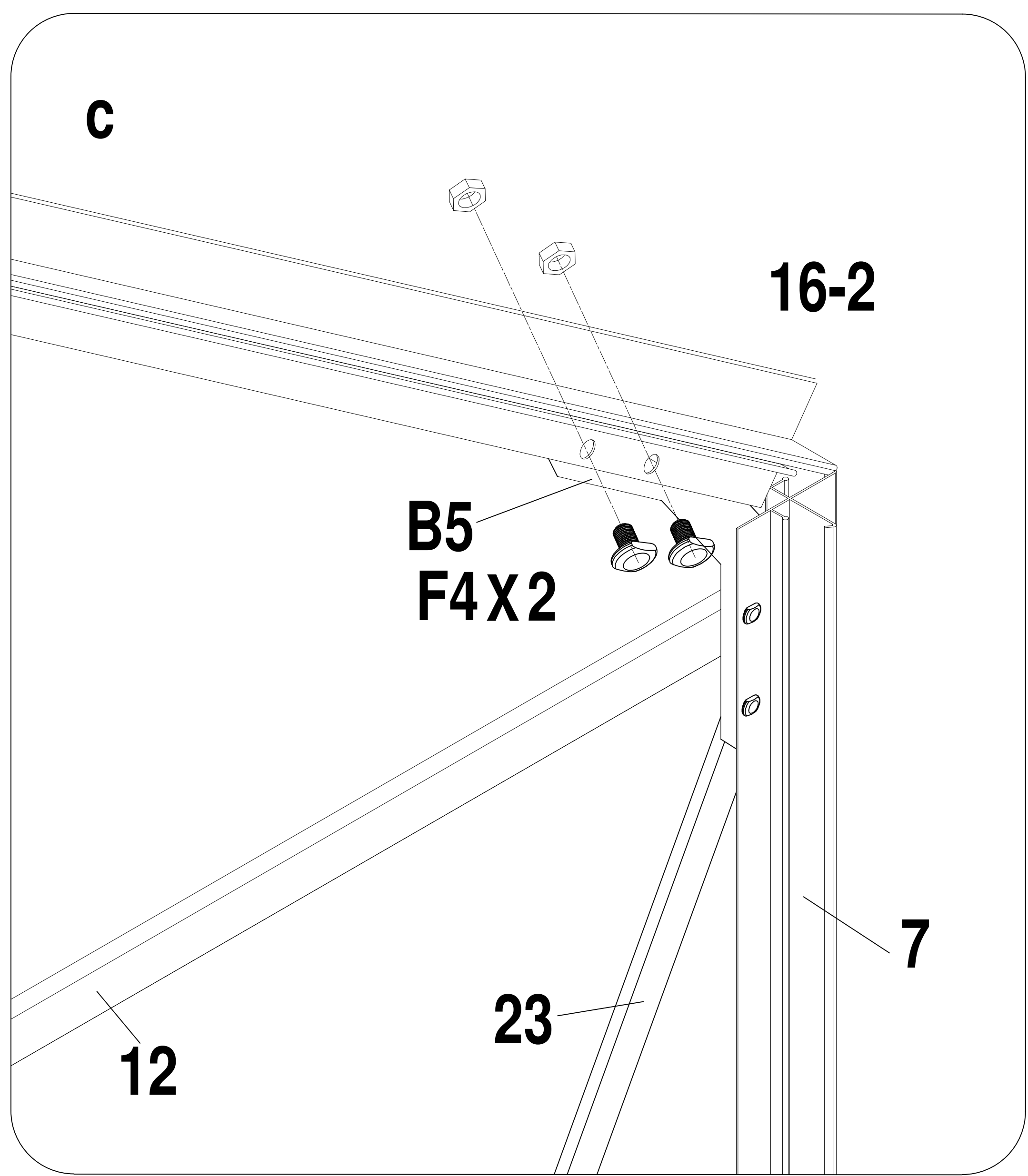
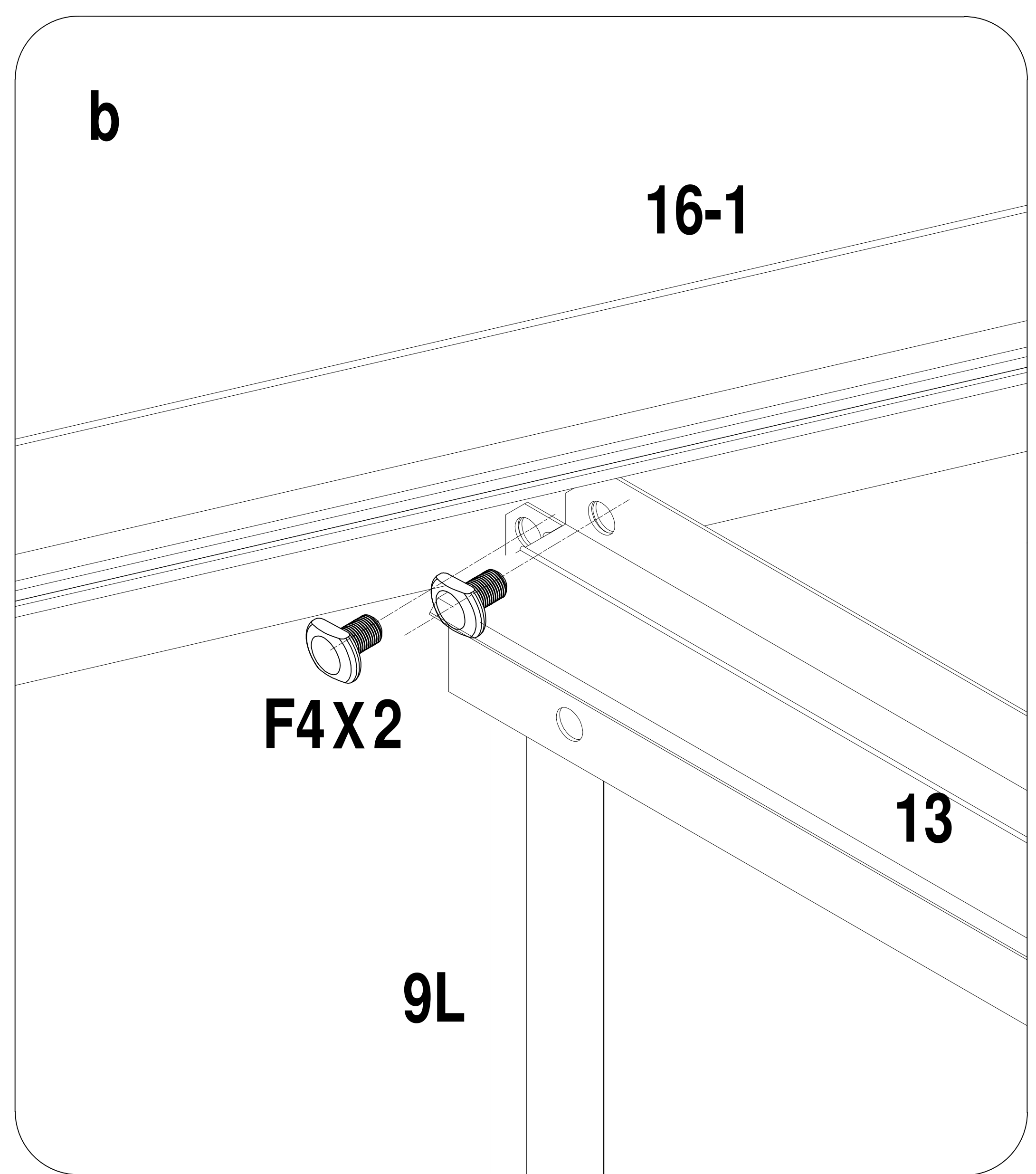
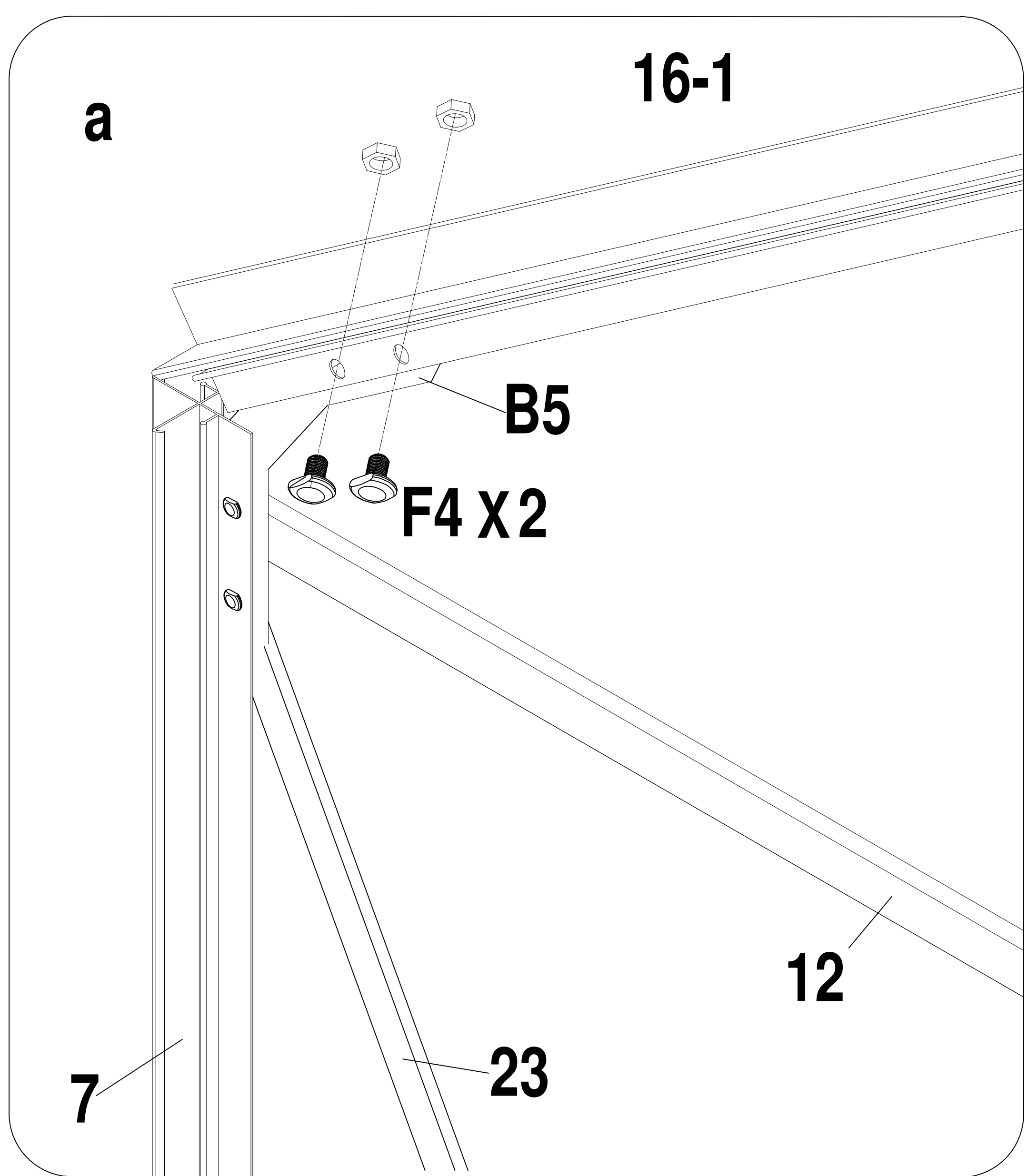
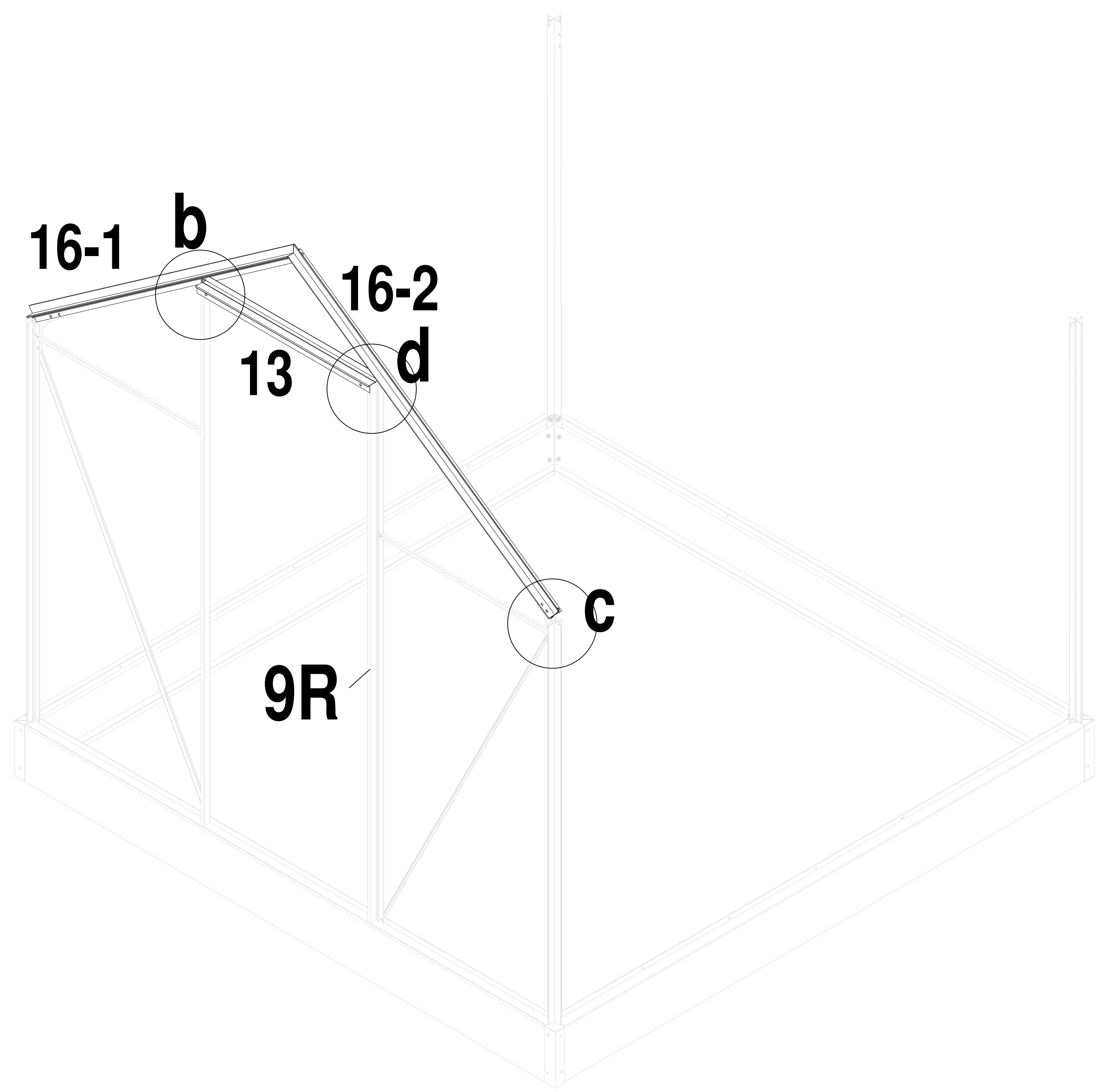

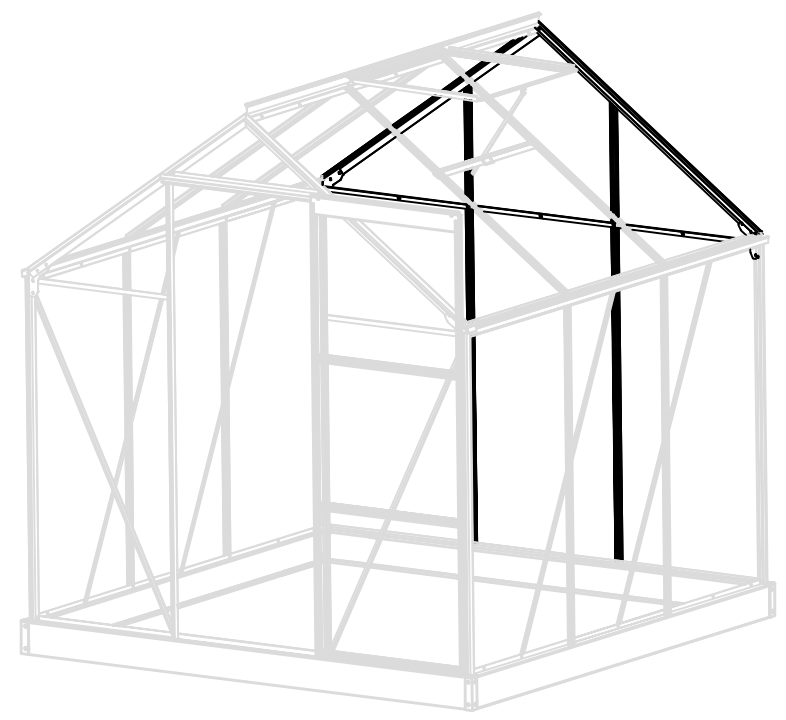

10Lx1

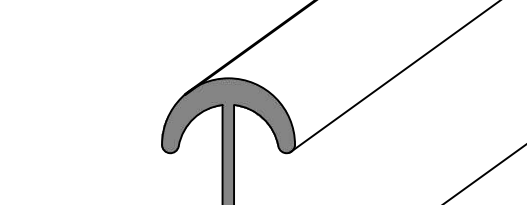

10Rx1

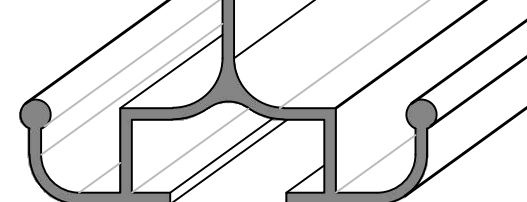

16-3 x1

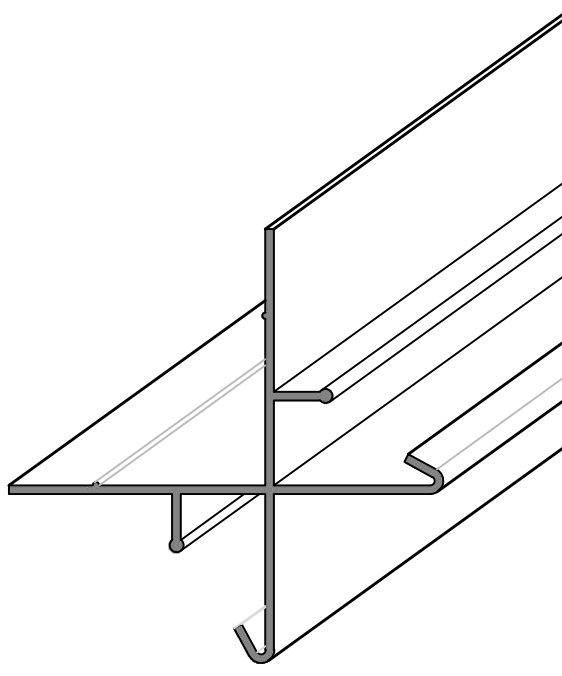

16-4 x1

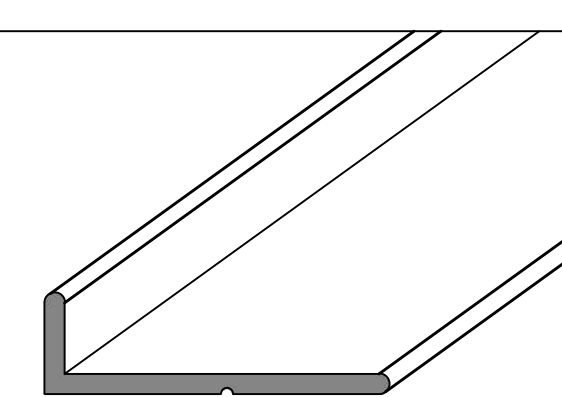

14 x1

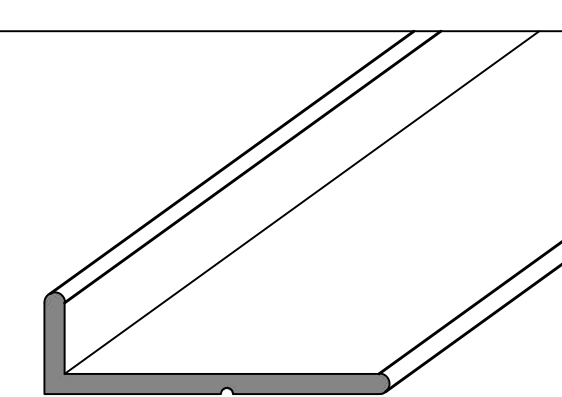

B5 x 2

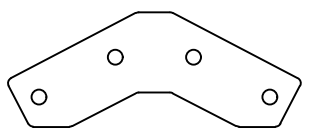

B2 x 2

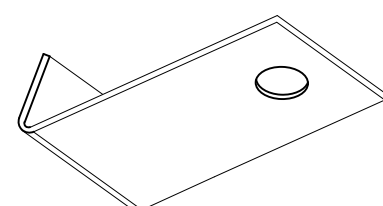

F4 x 14

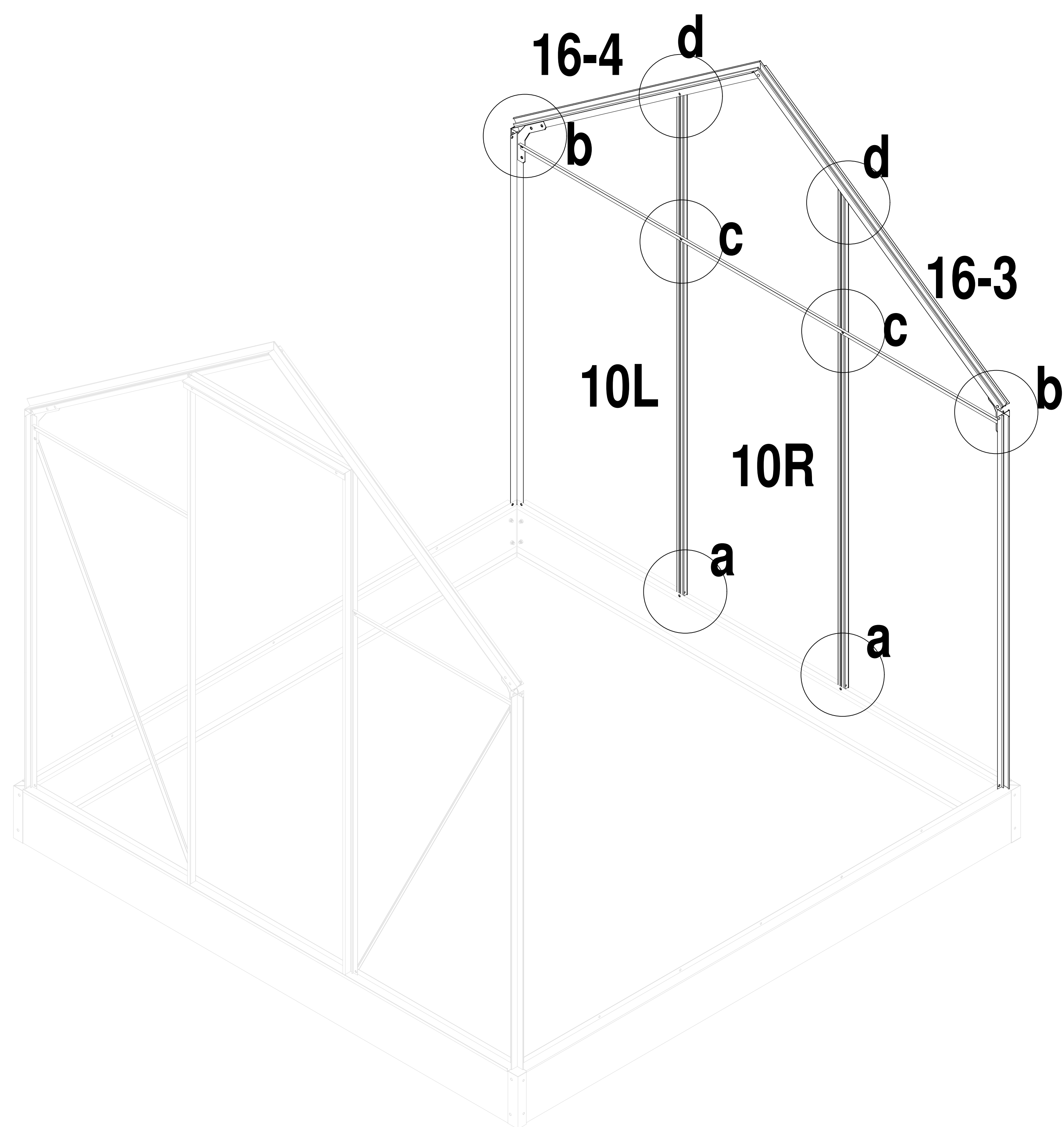
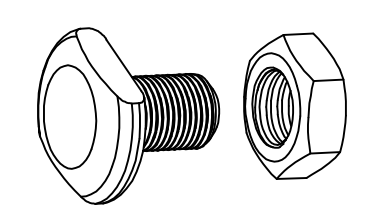

F4 X 3

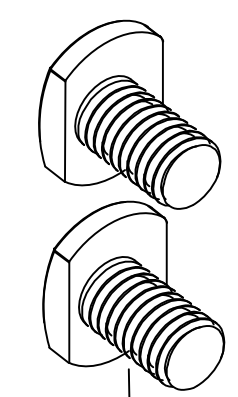

10L/10R

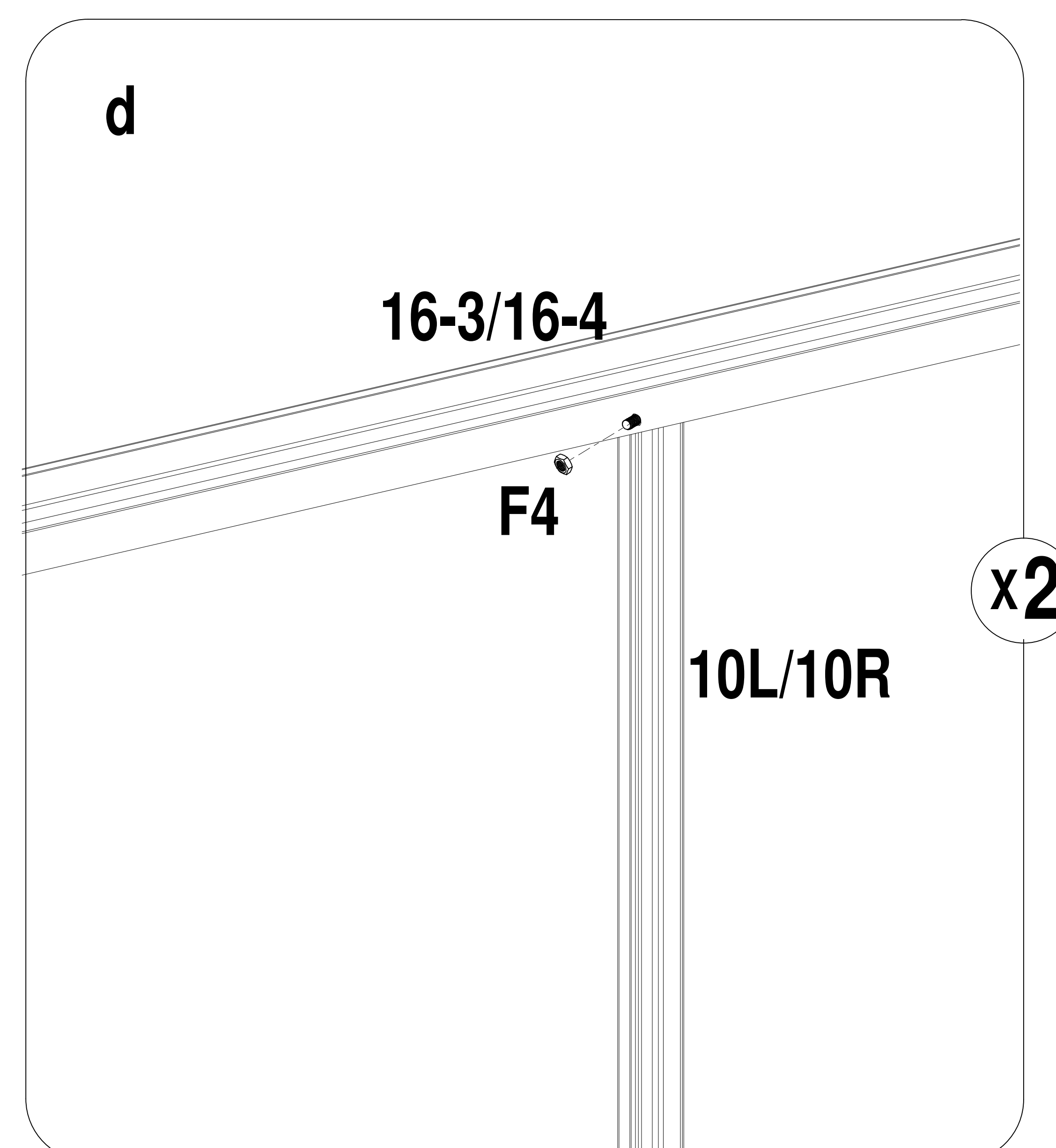
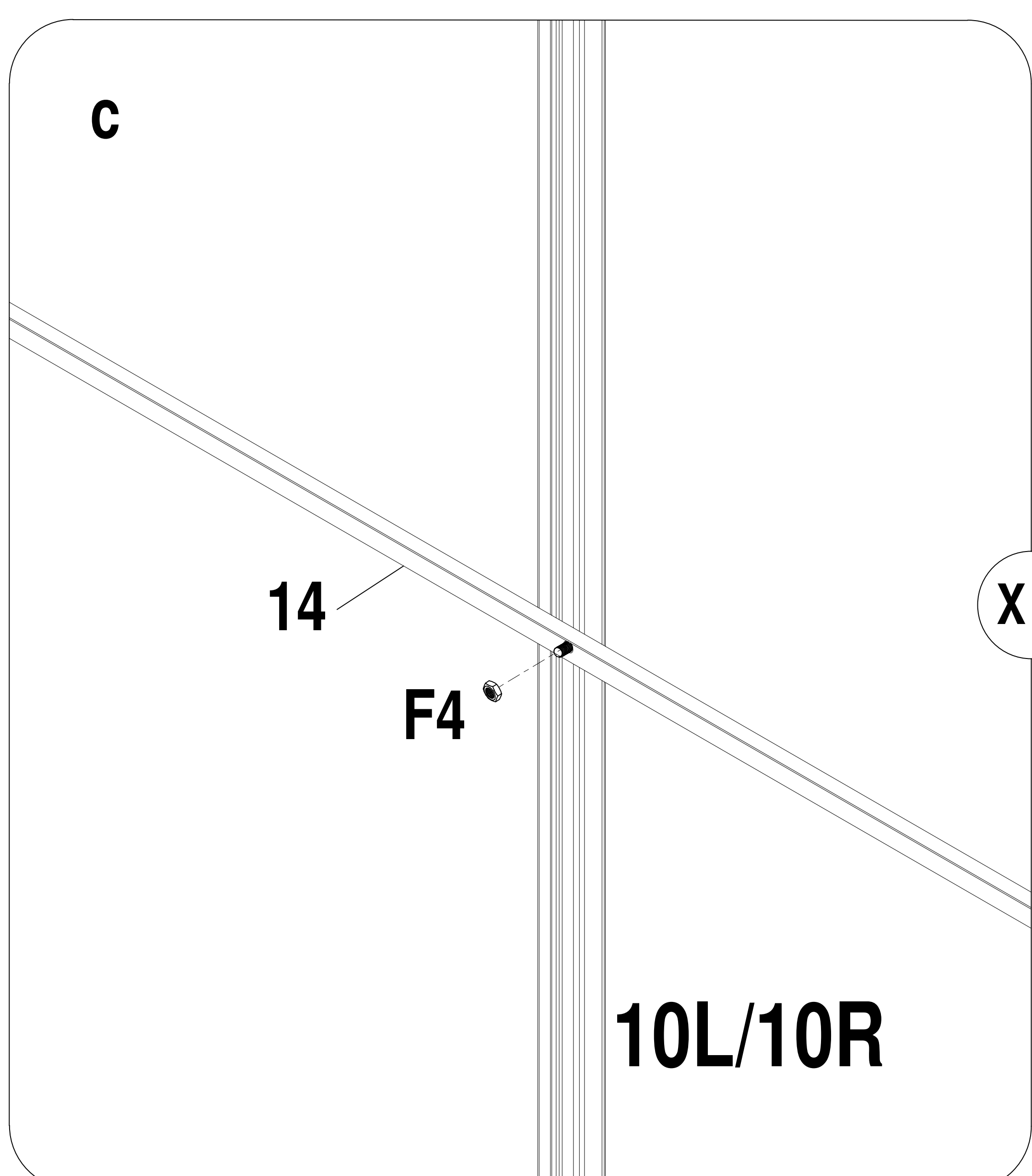
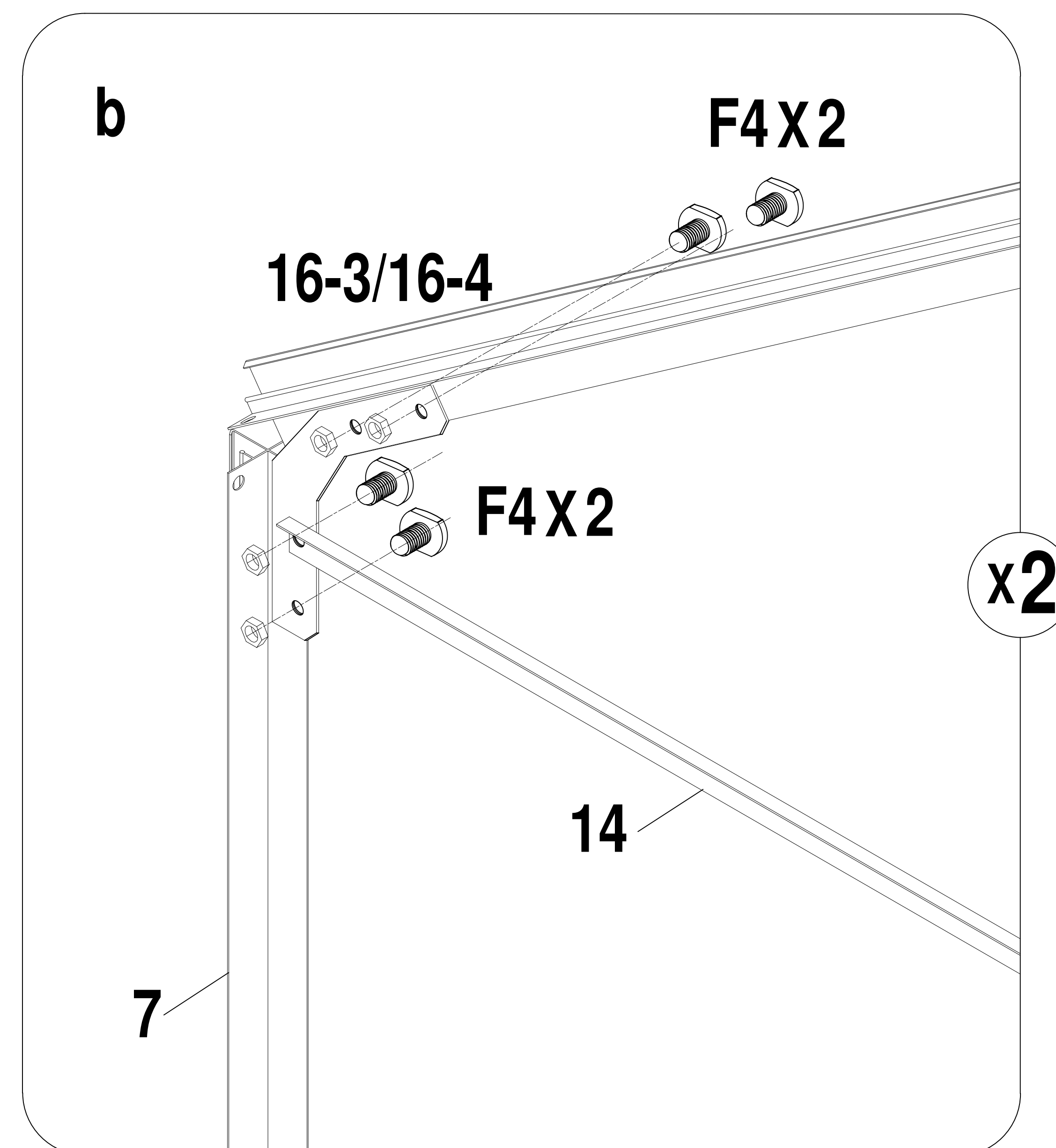
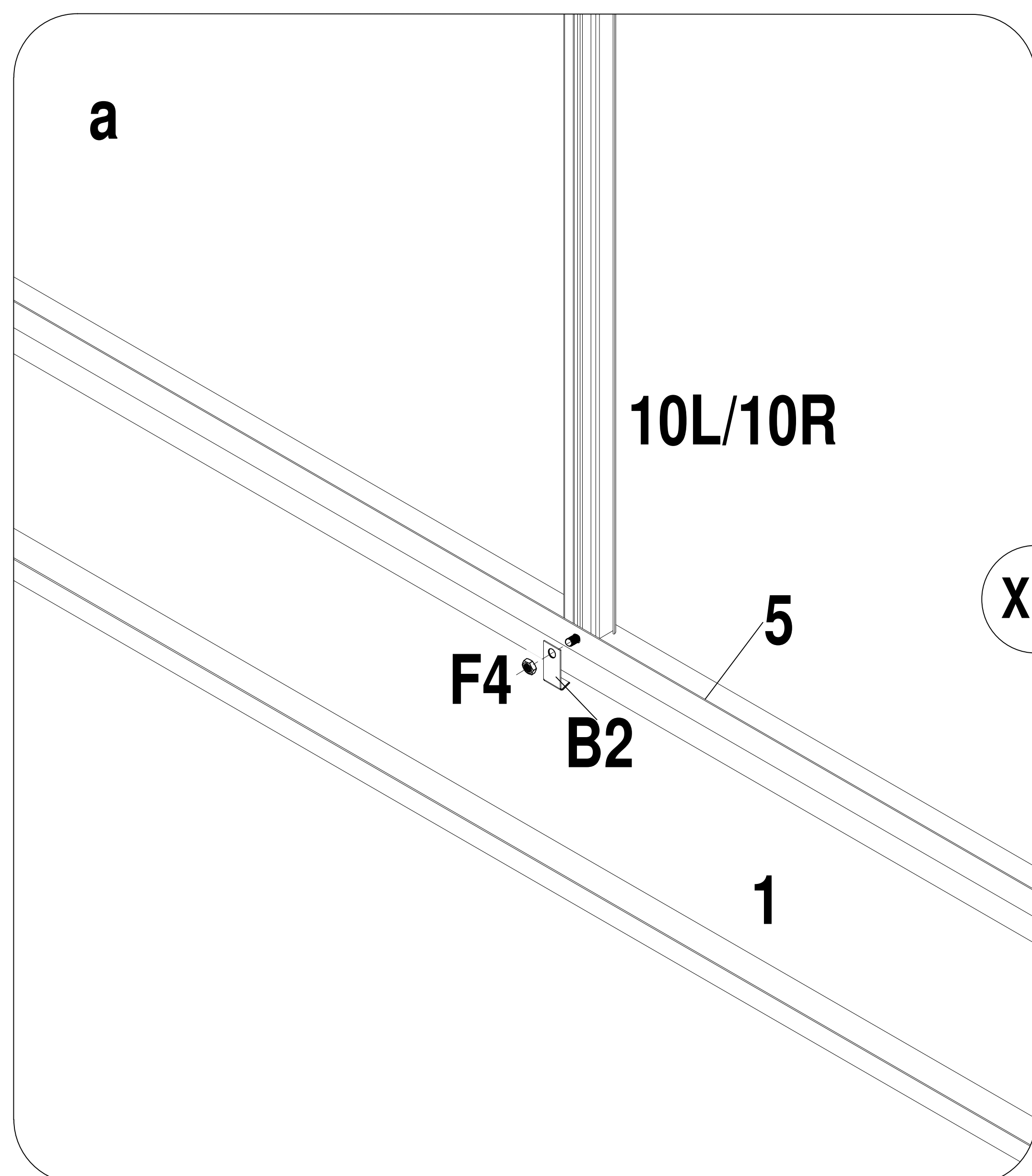
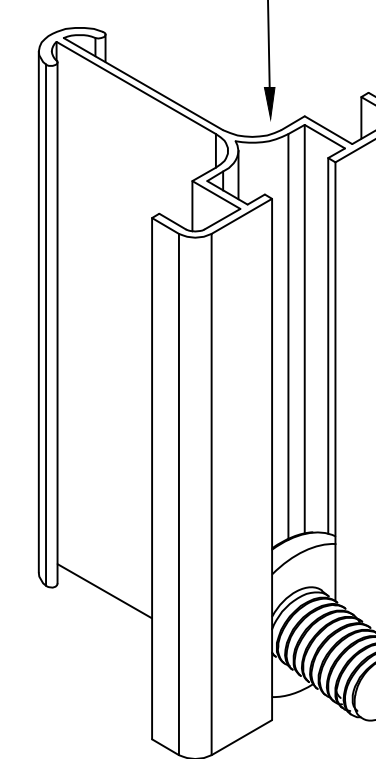

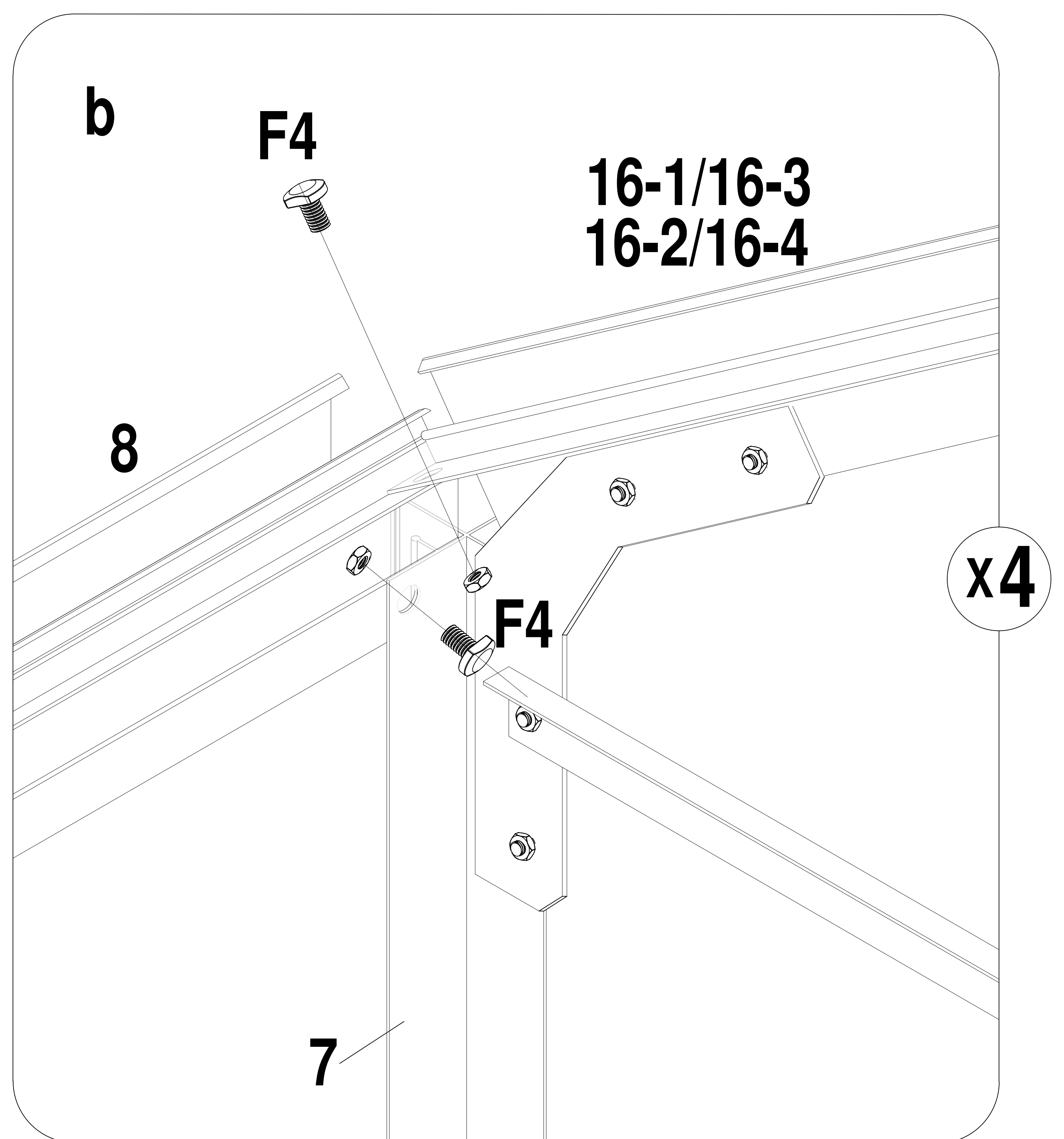
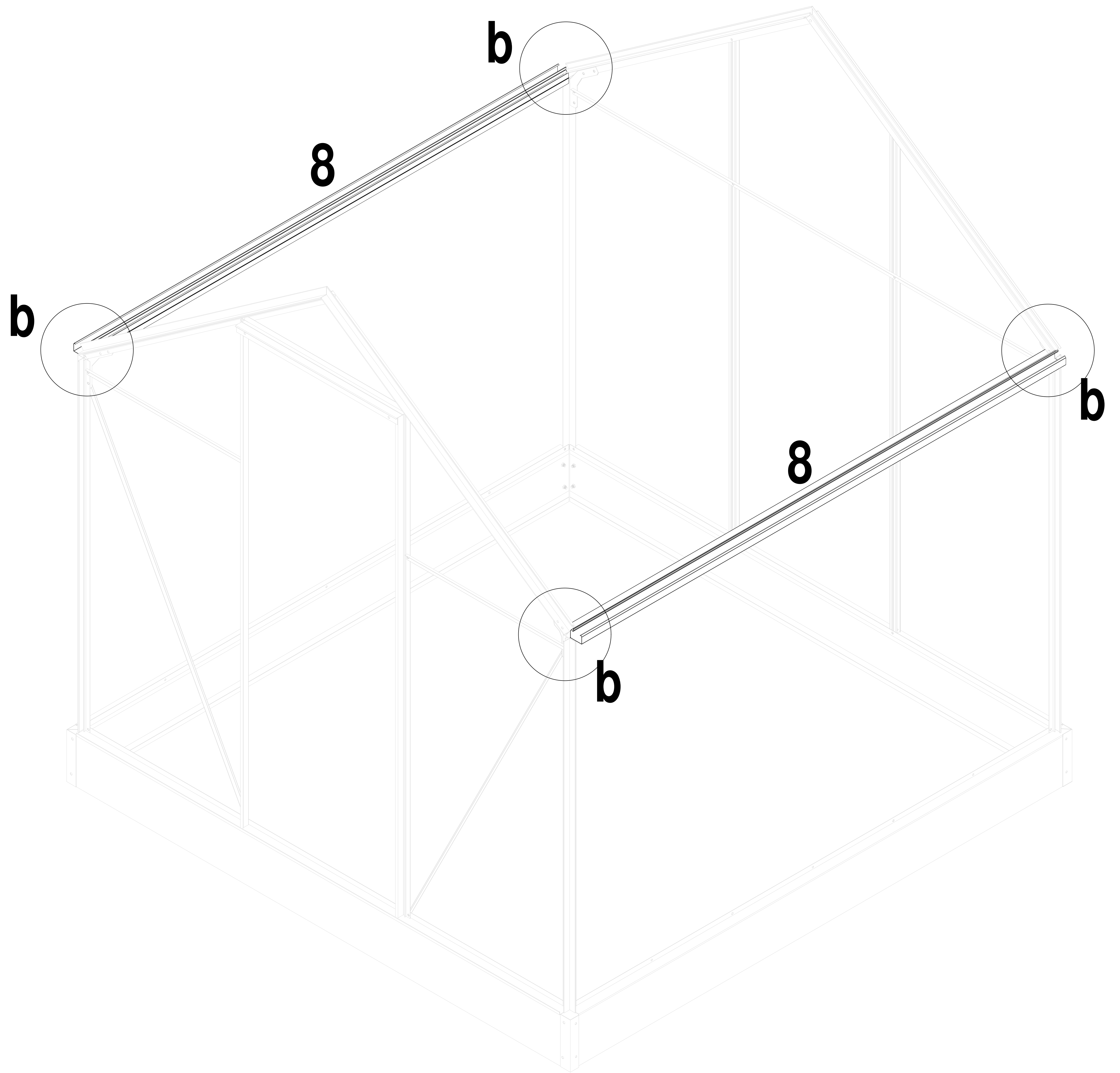
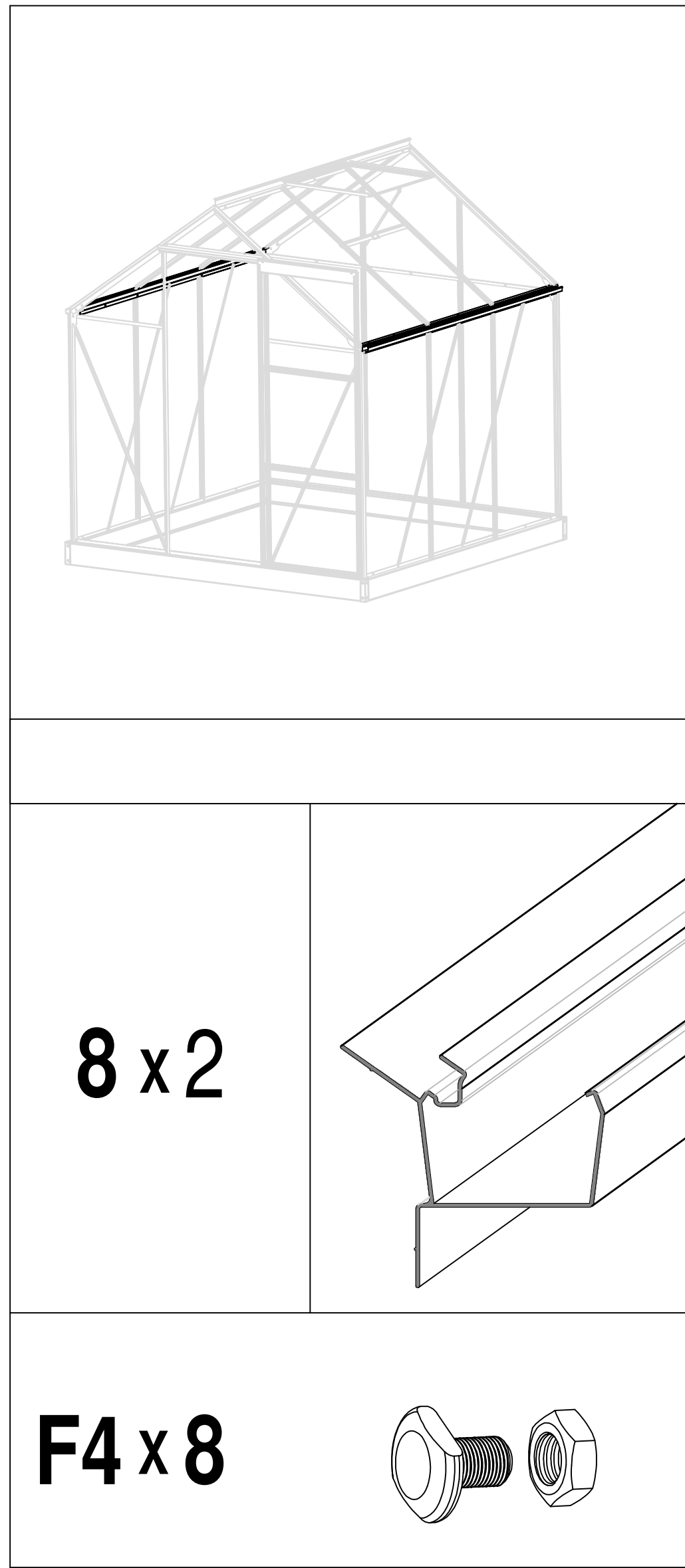

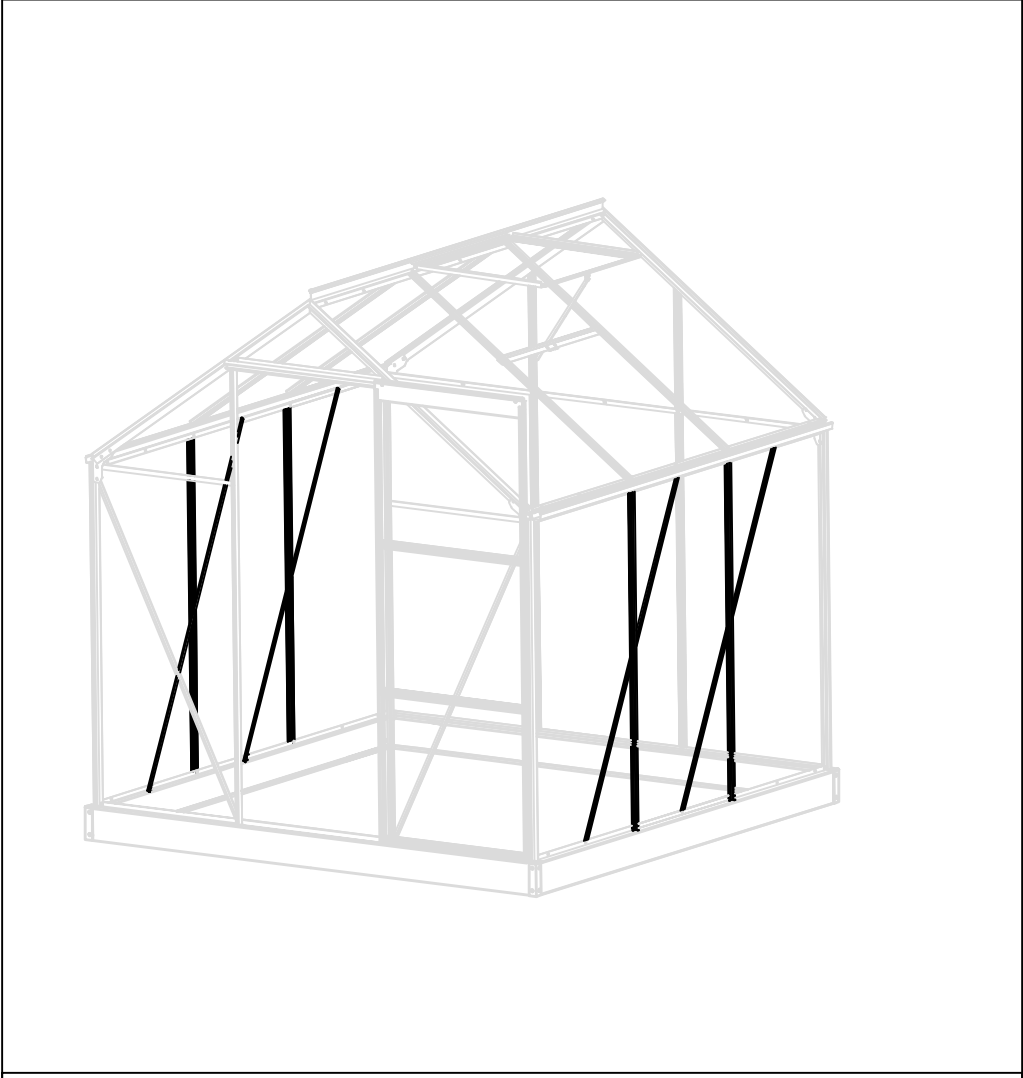

19 x 4	
22 x 4	
B2 x 4	
F4 x 24	

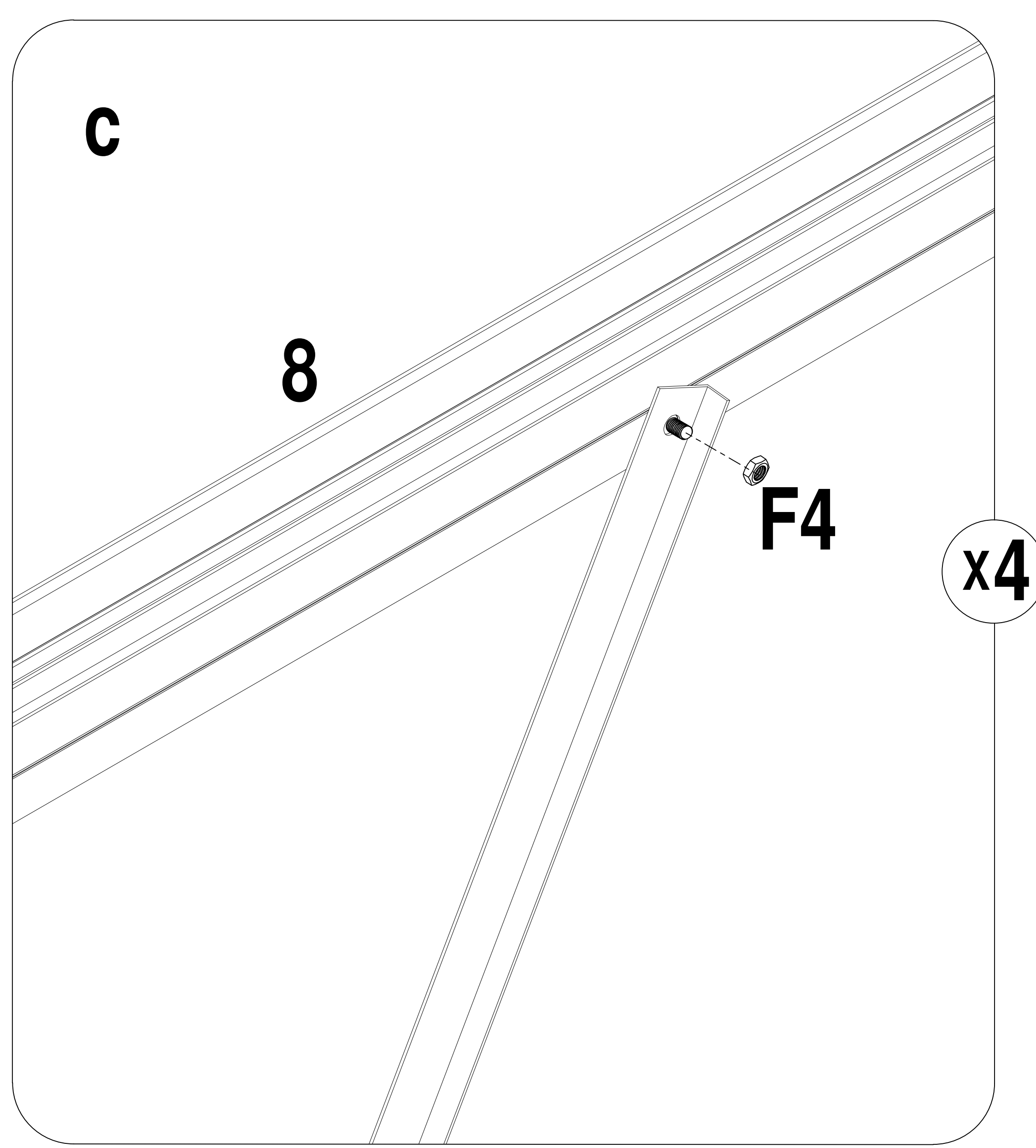
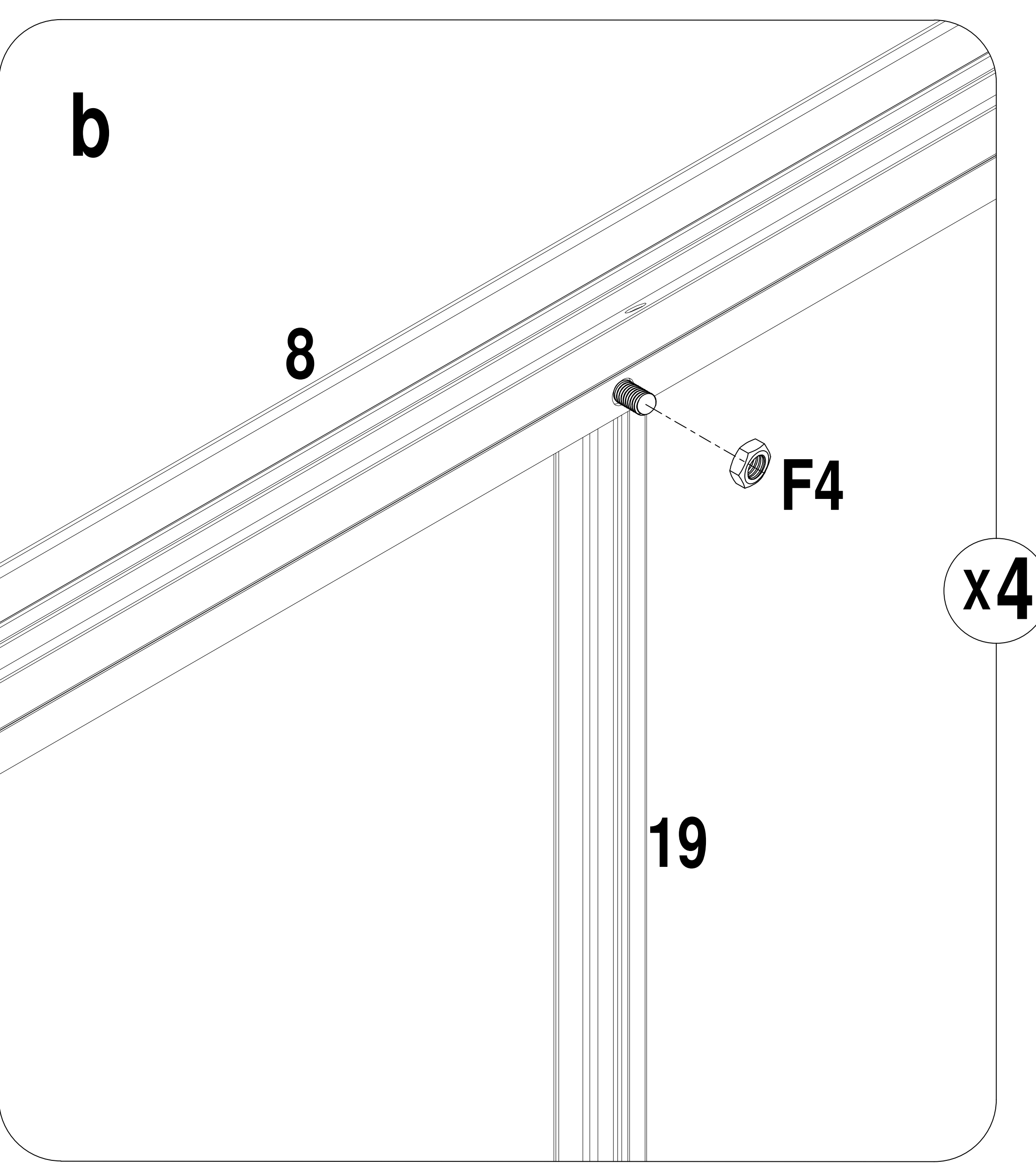
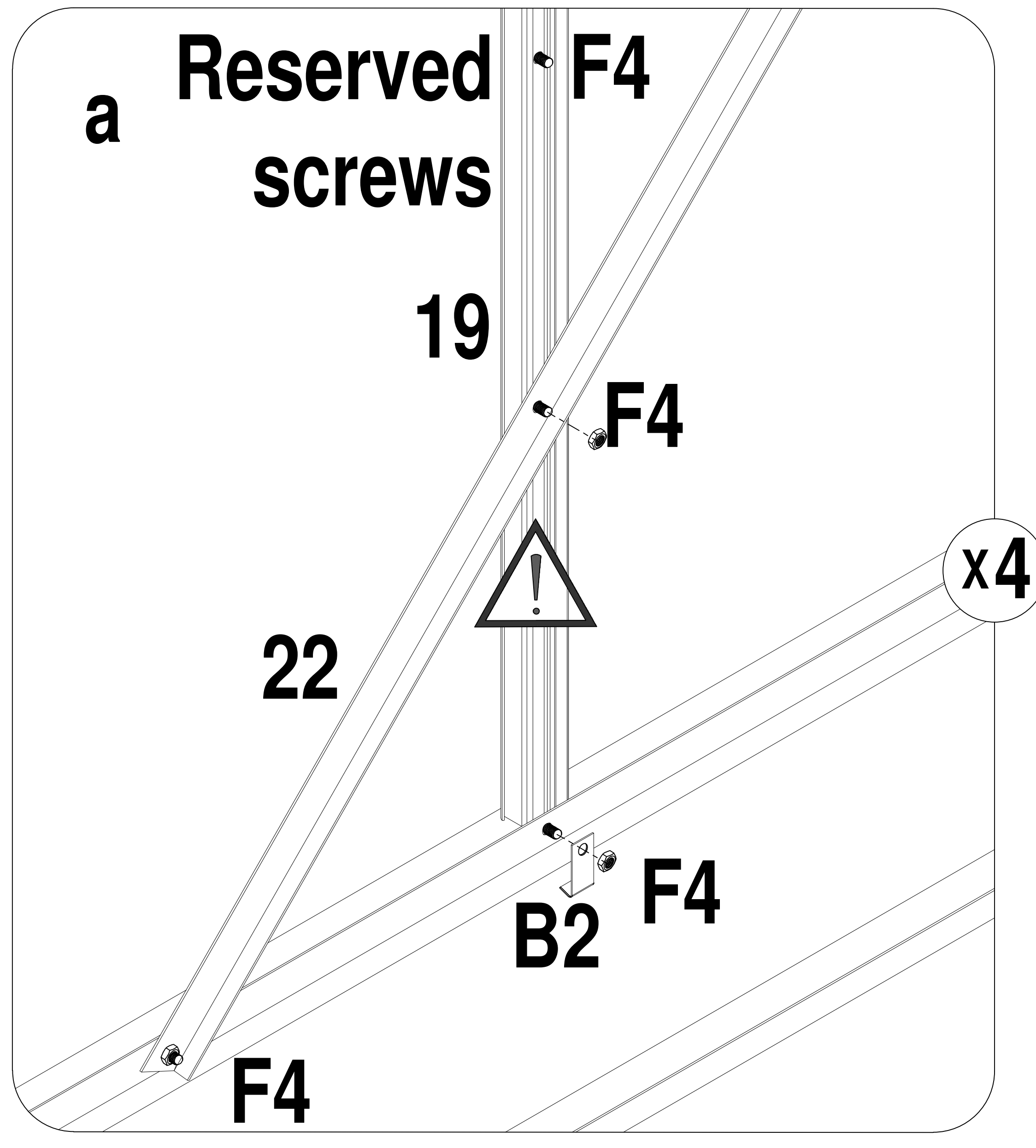
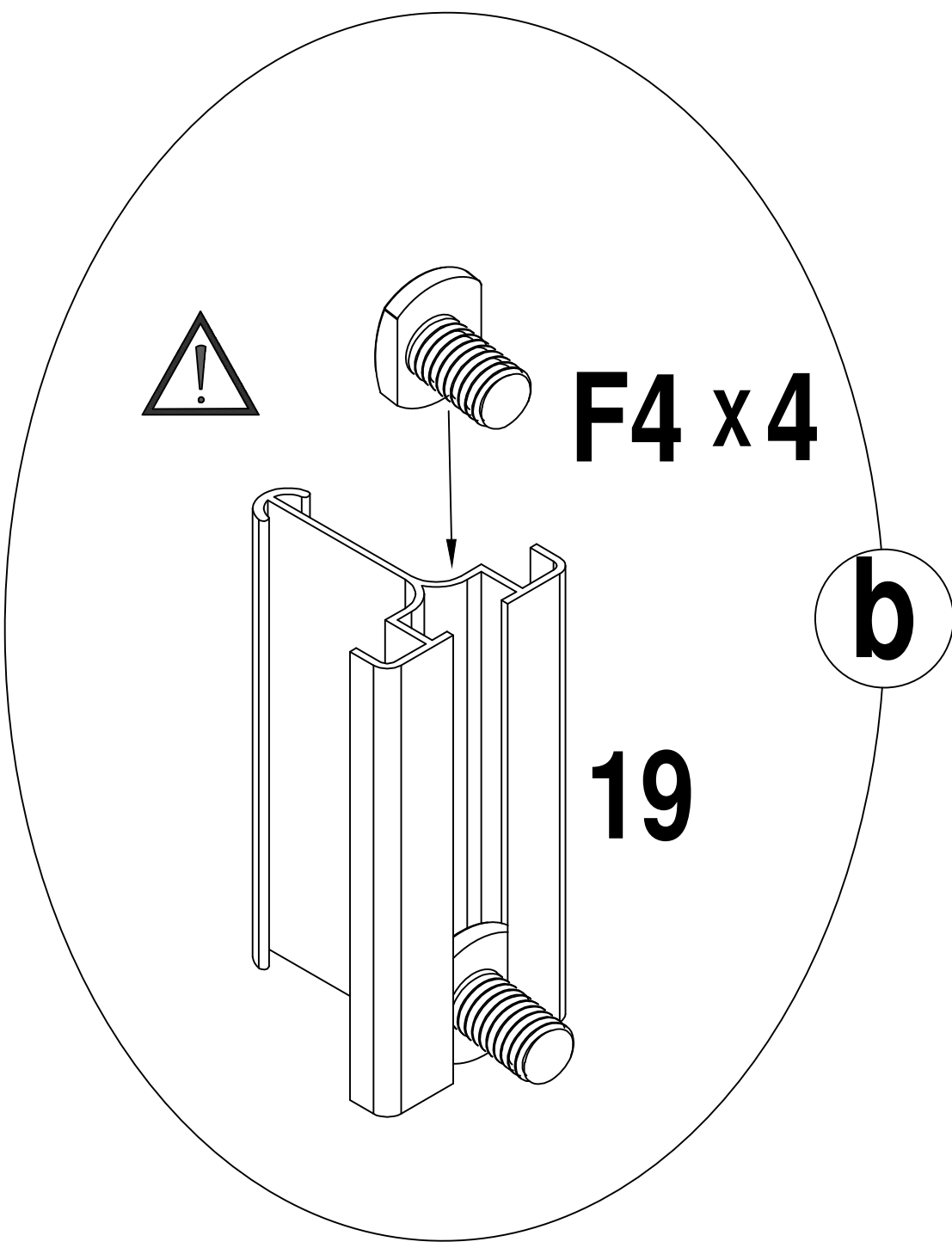
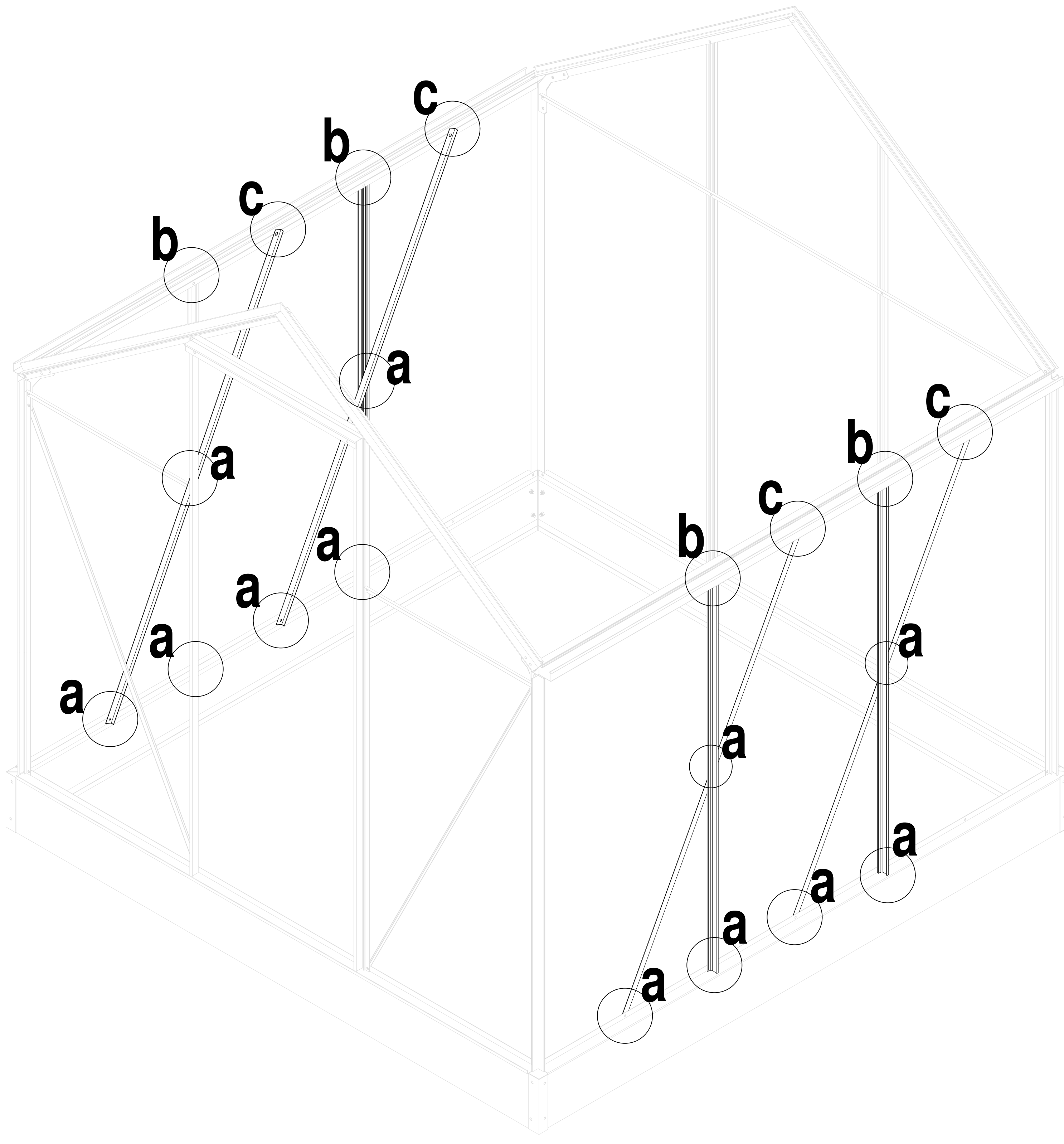

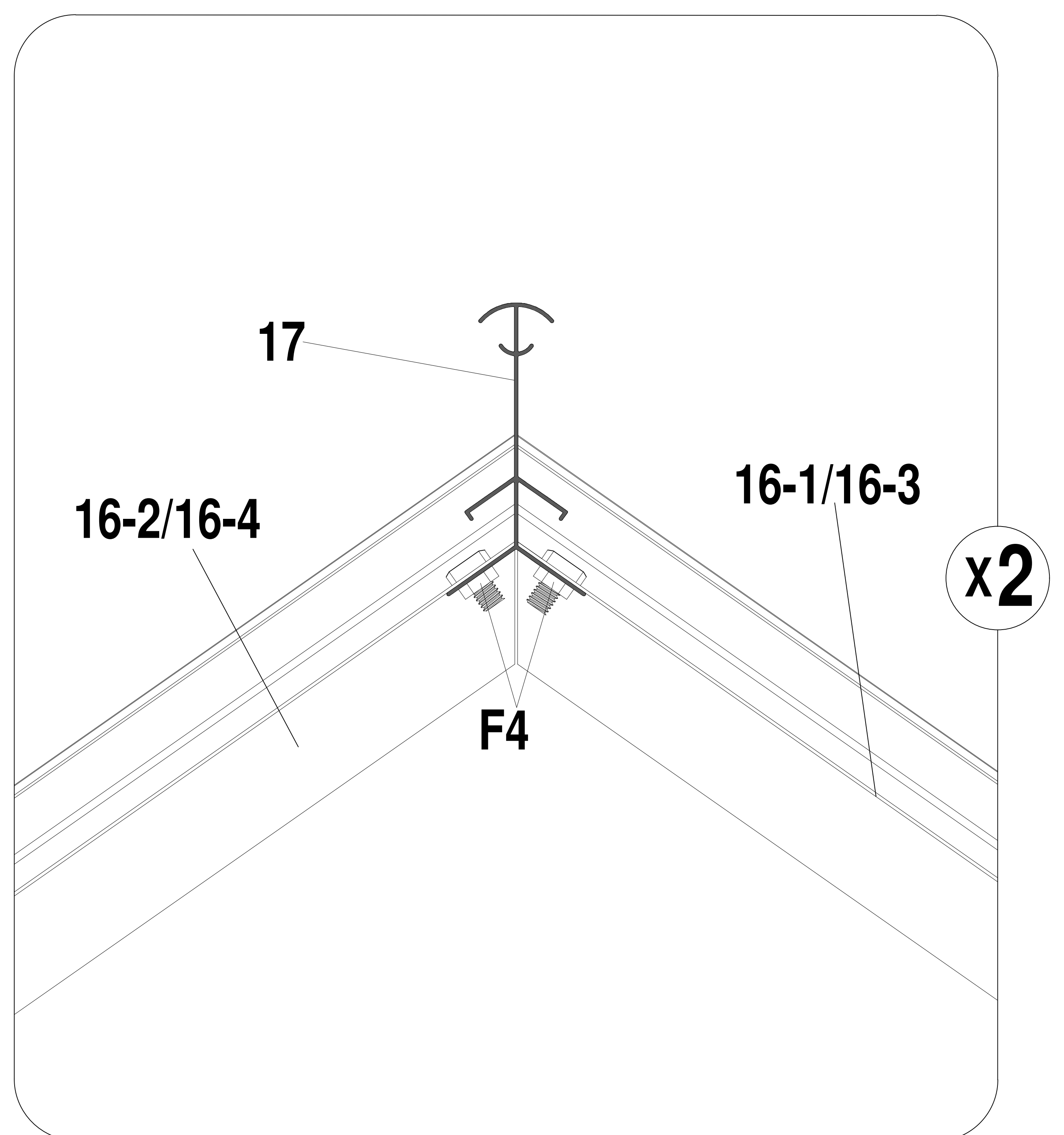
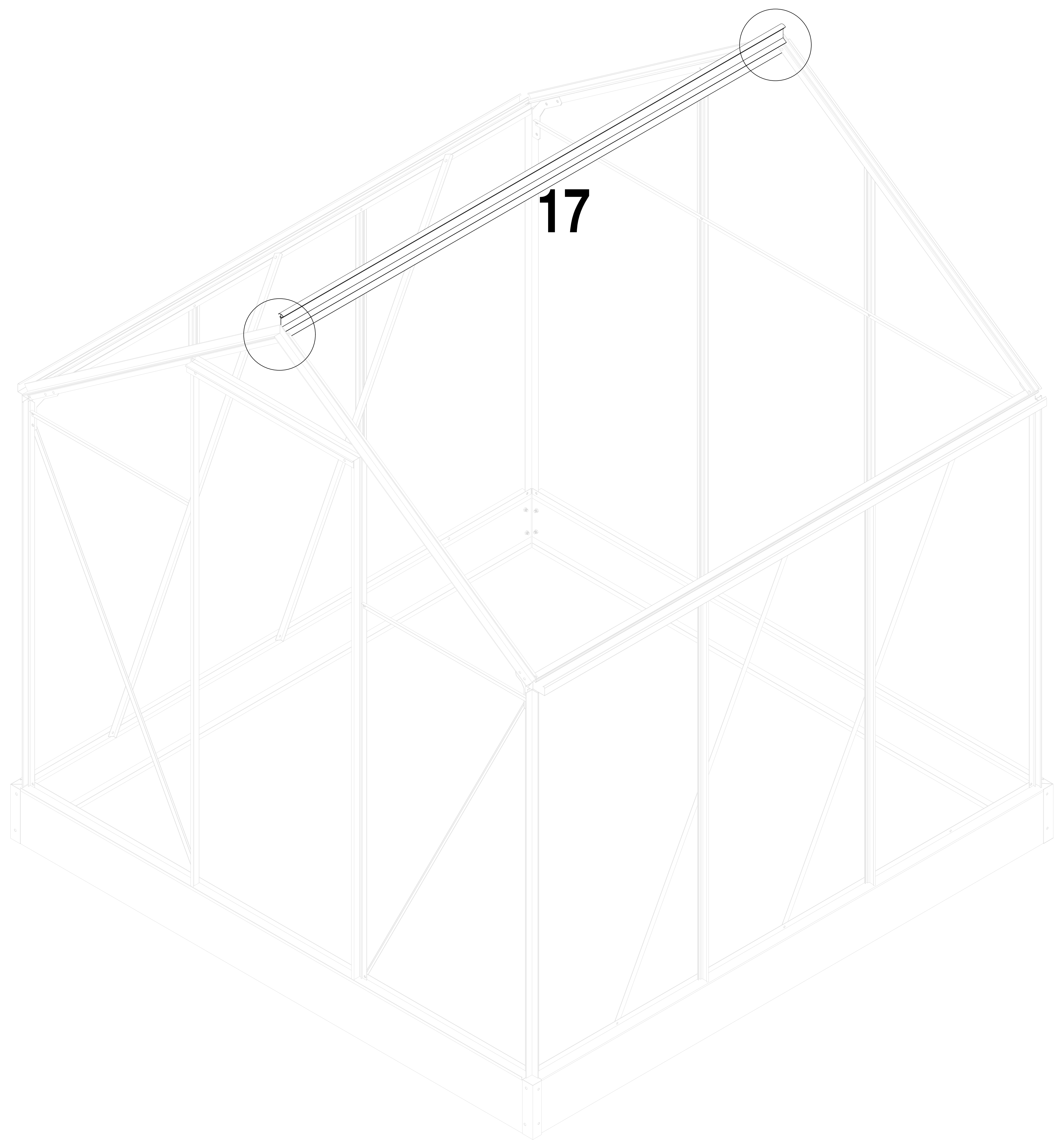
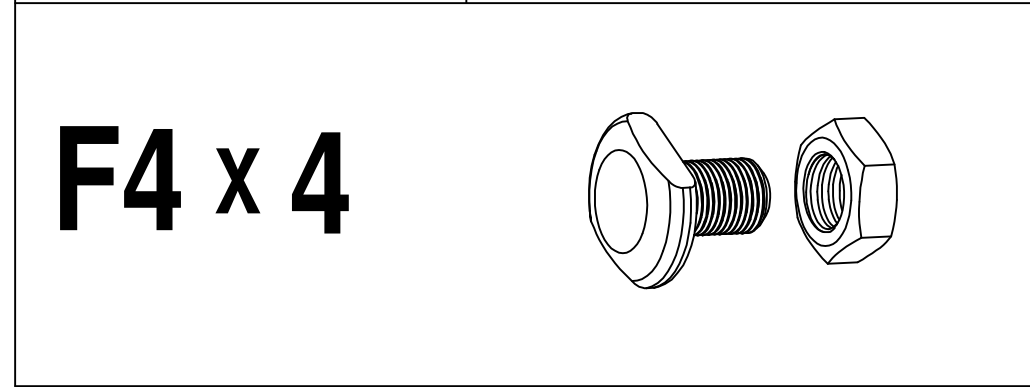
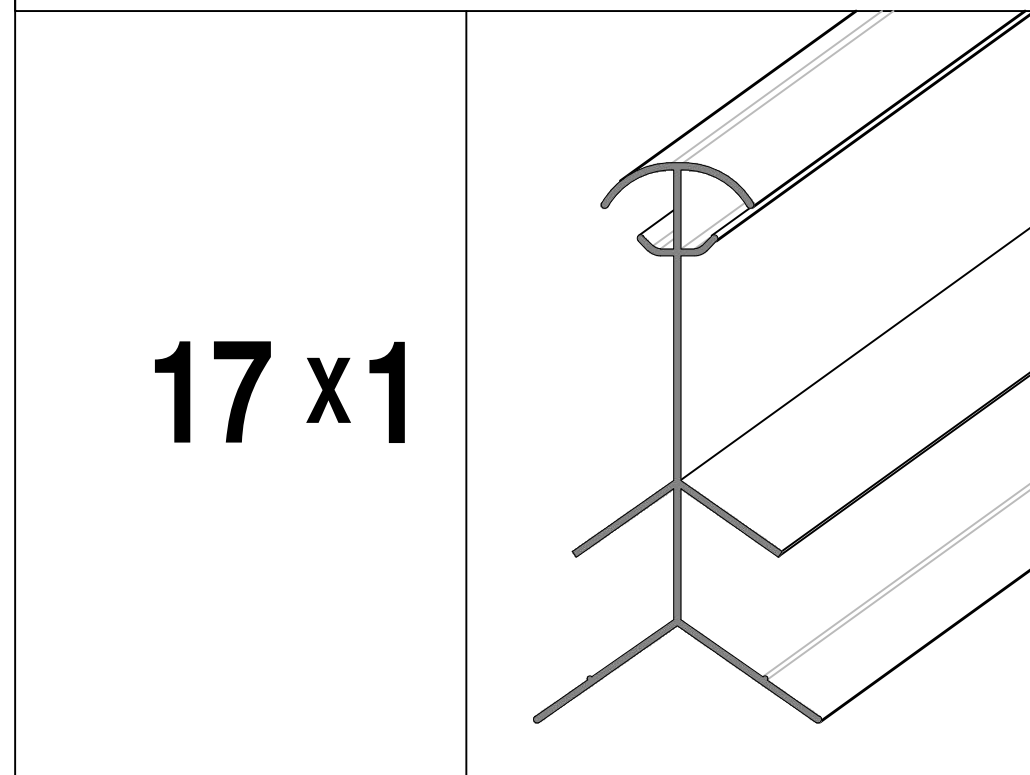
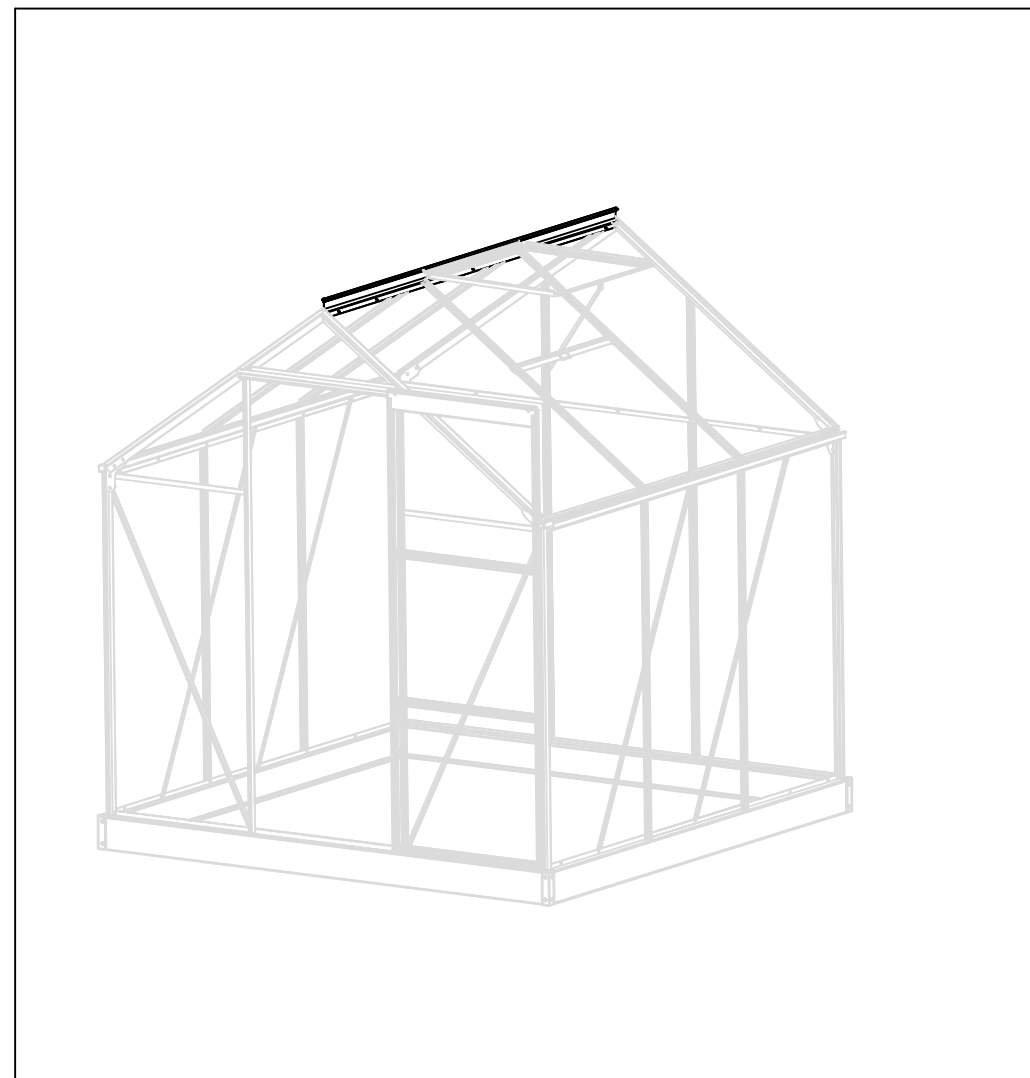

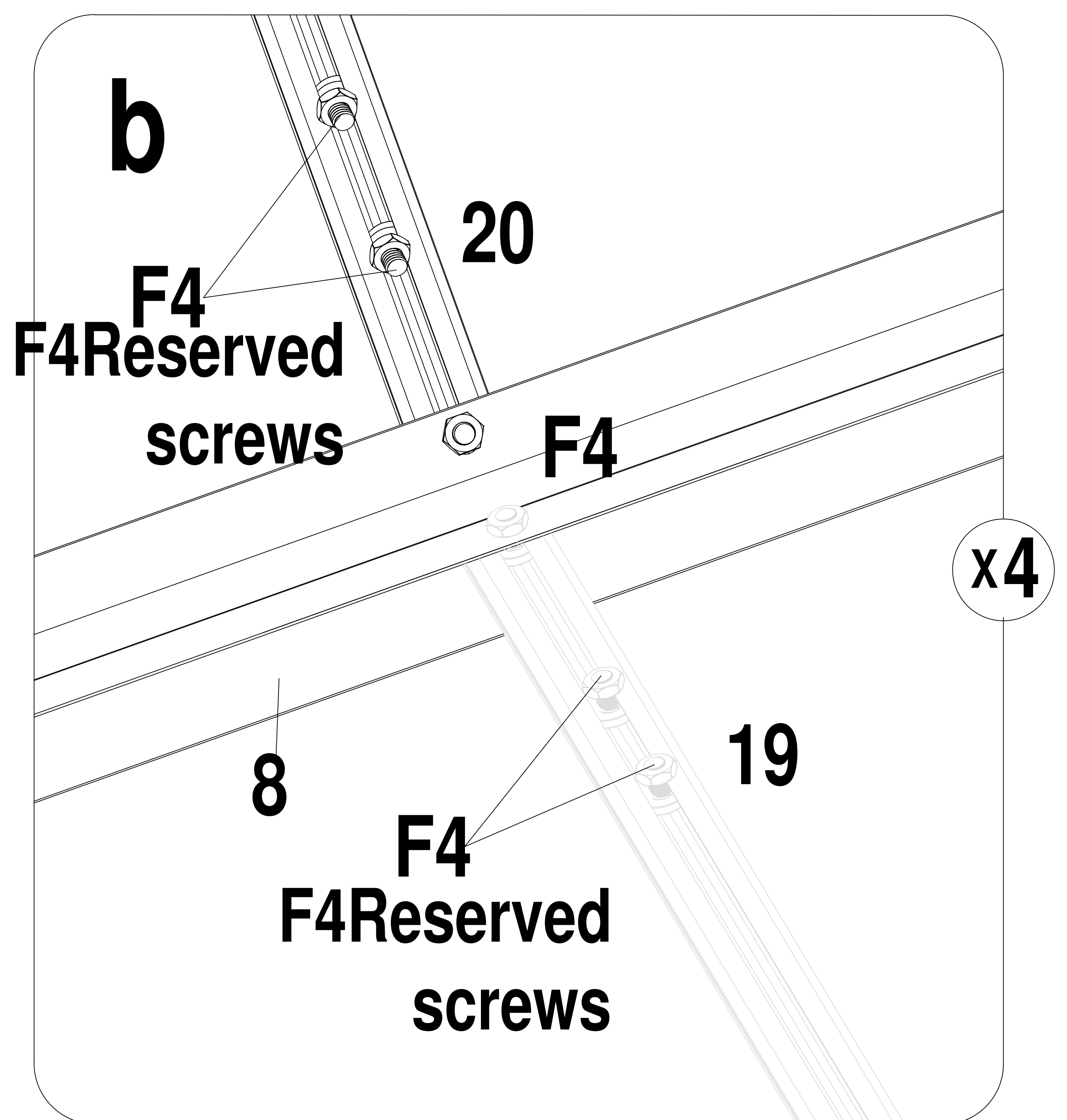
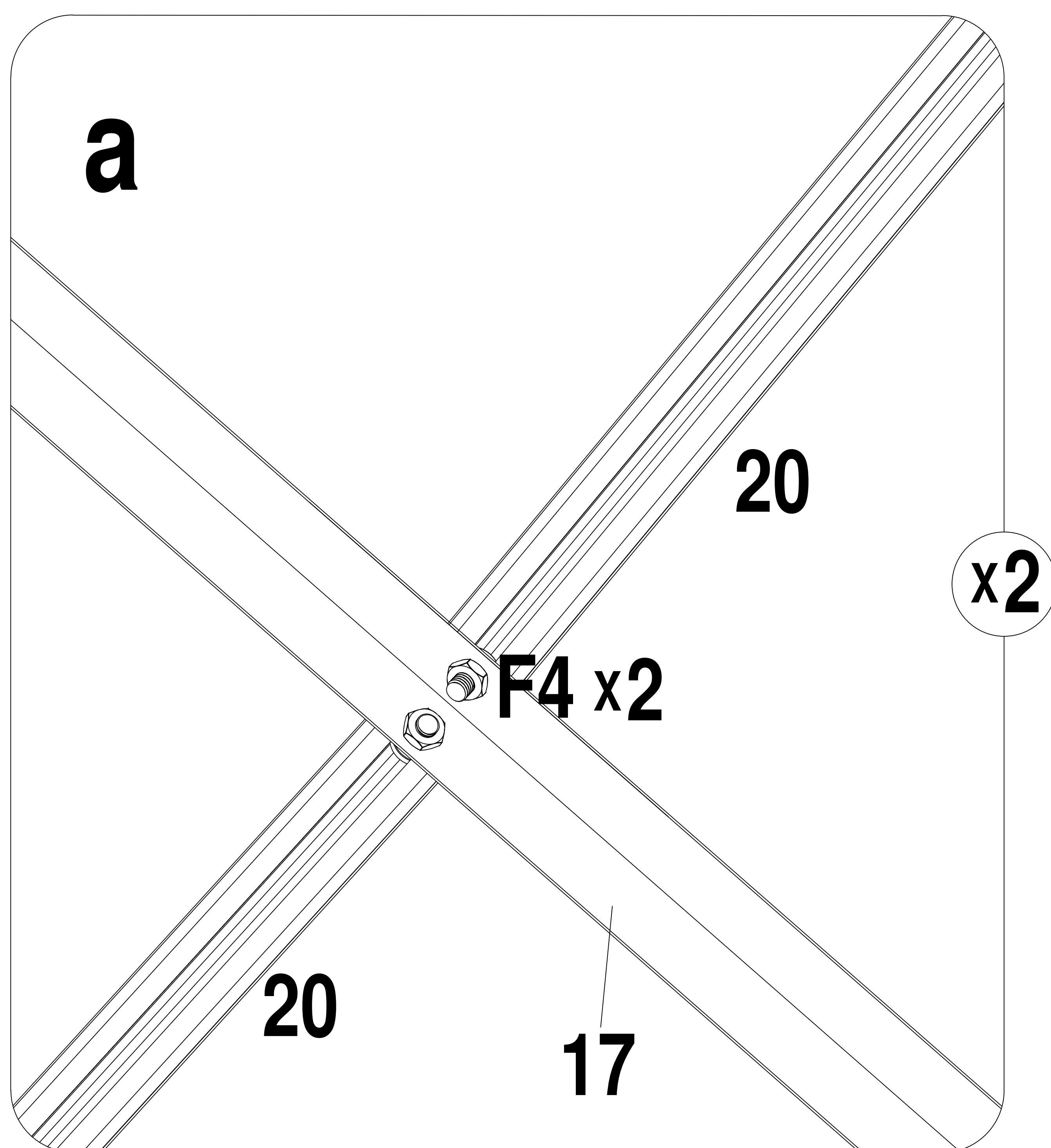
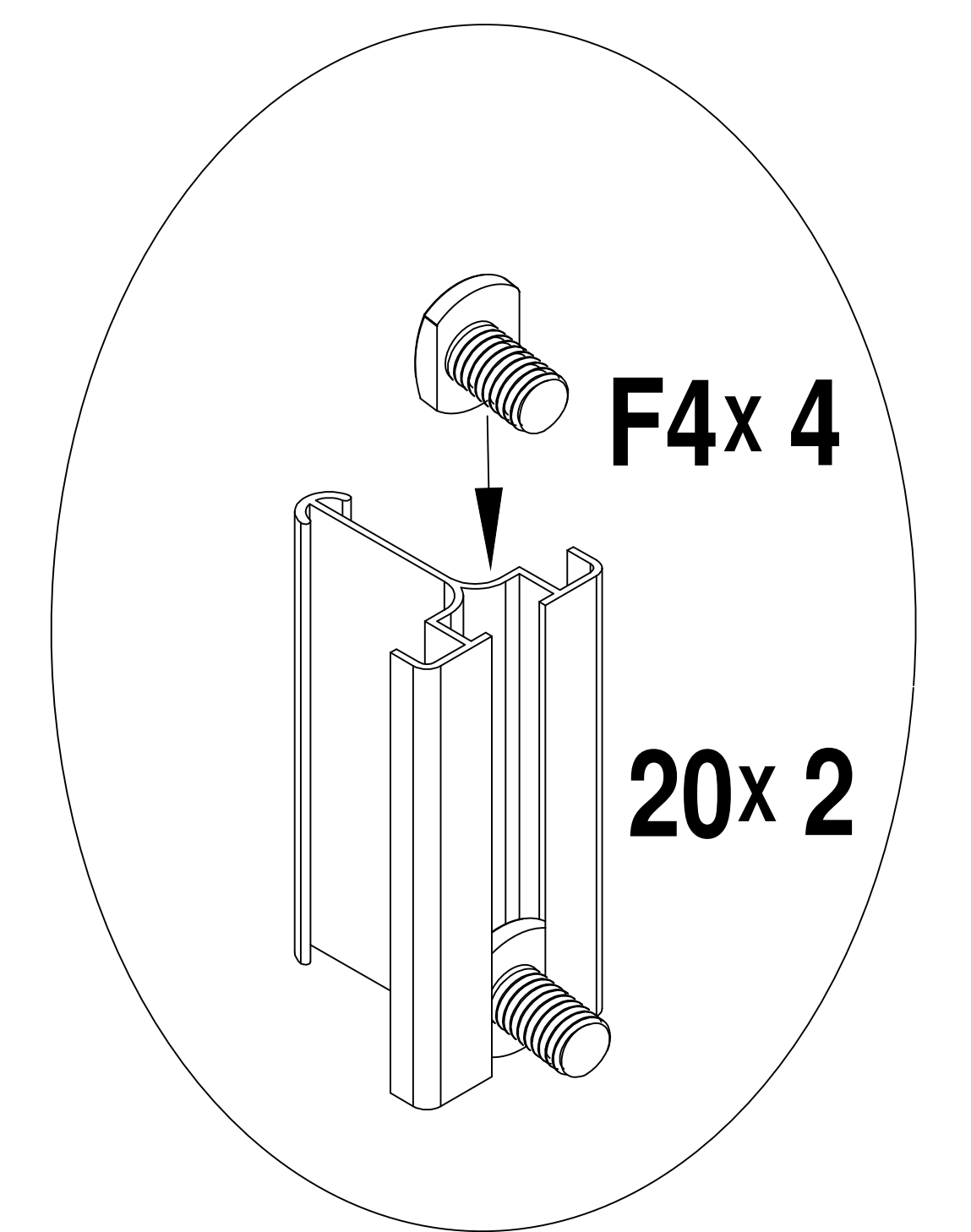
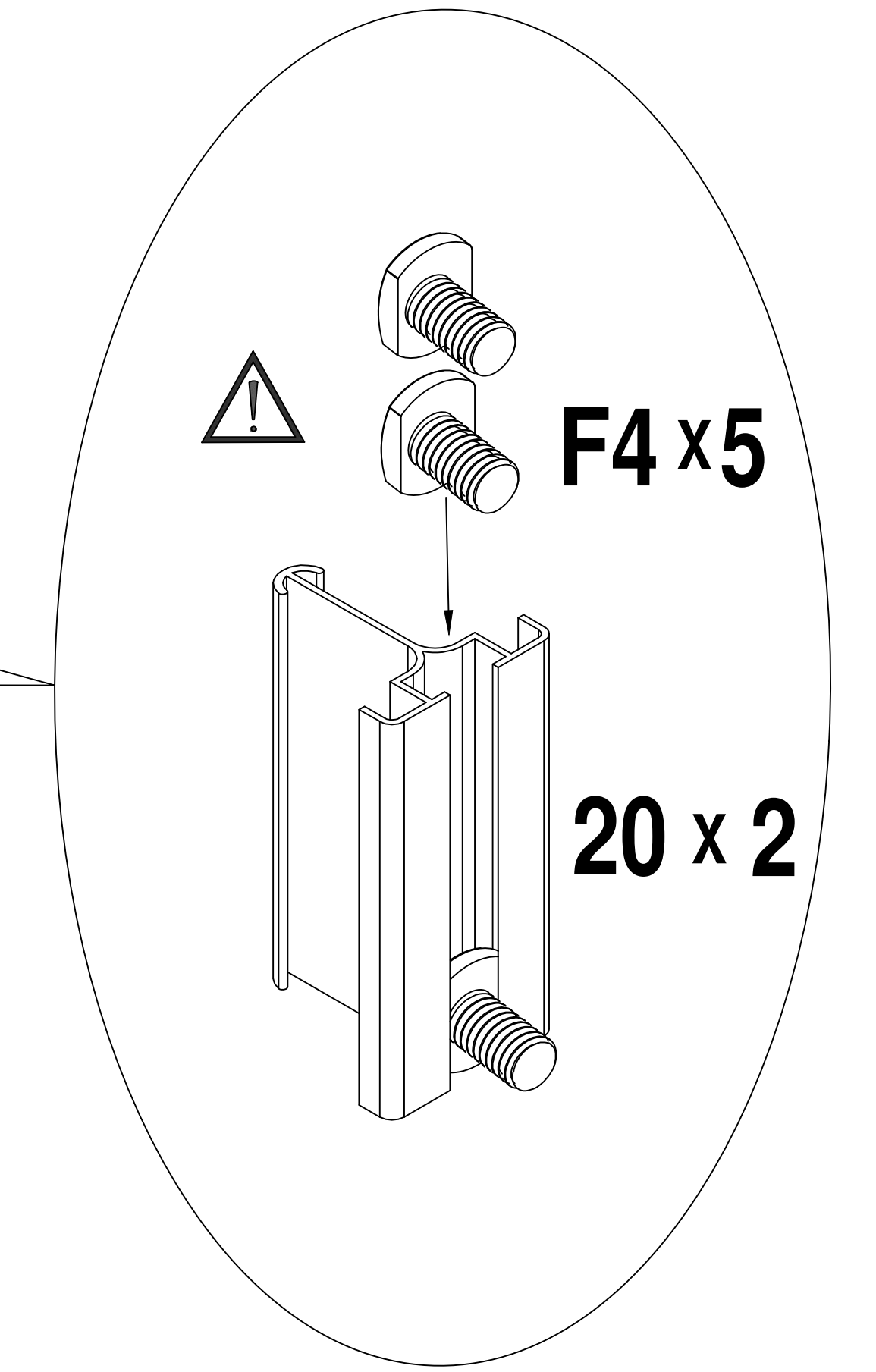
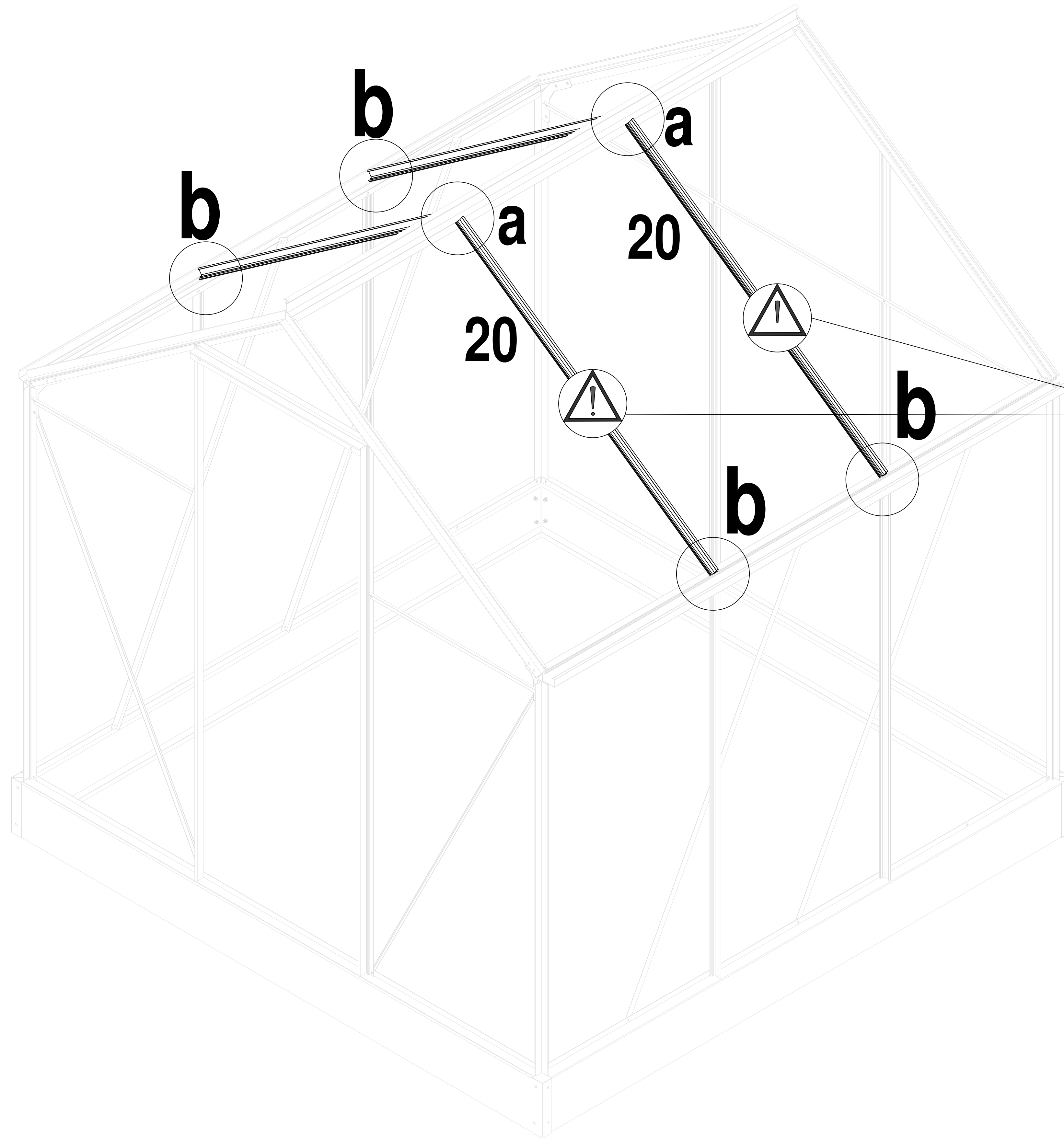
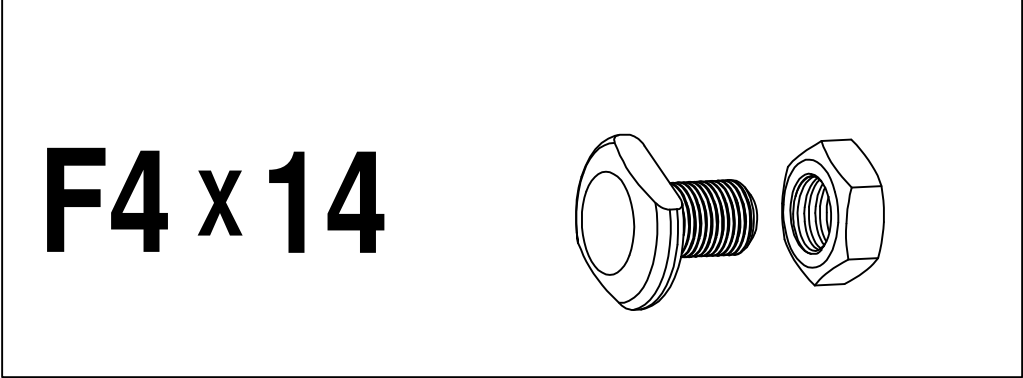
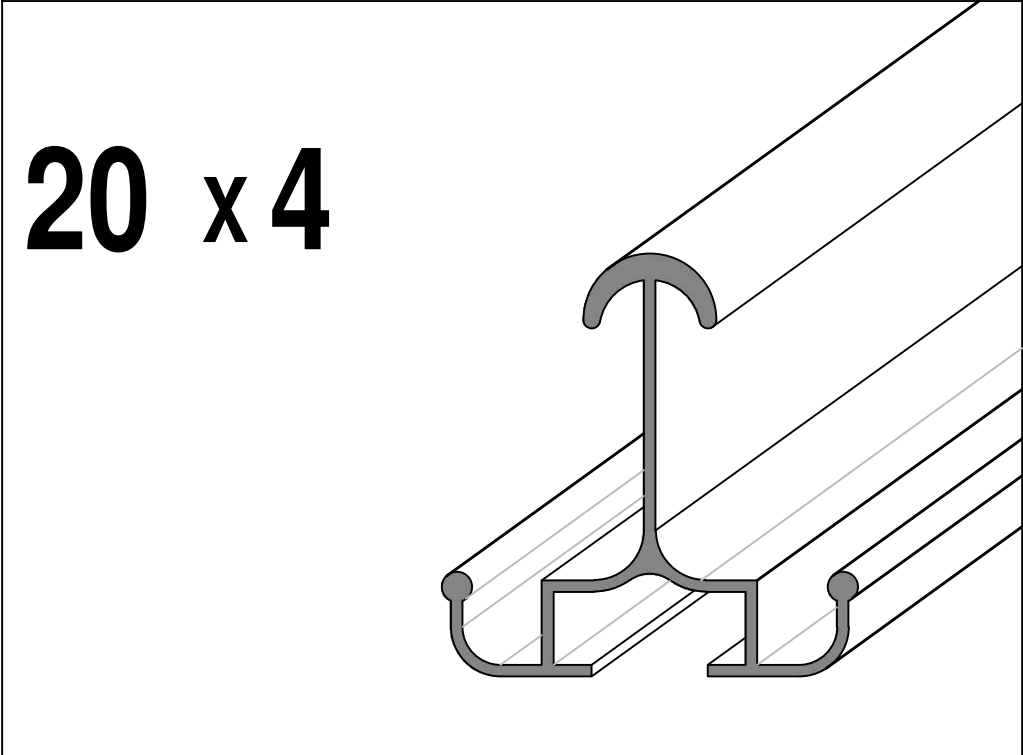
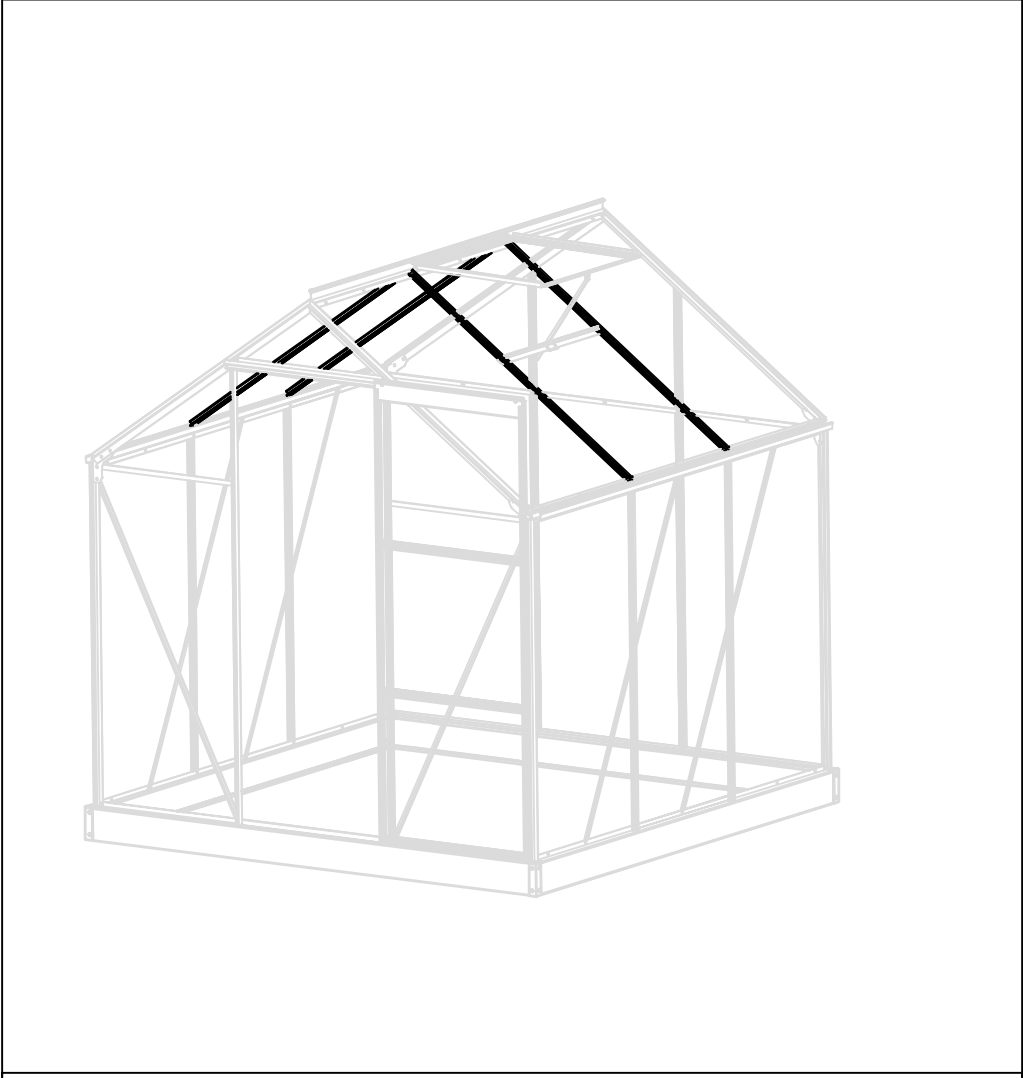

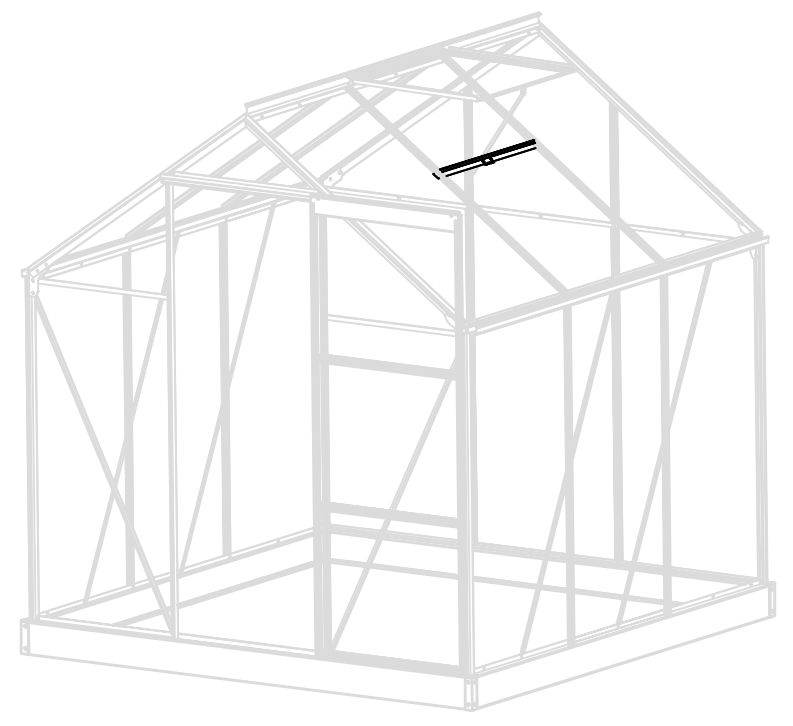

21 x1

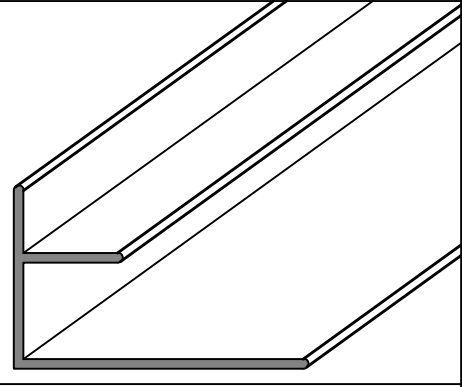

B4 x1

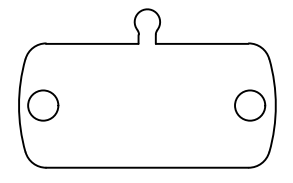

B8 x1

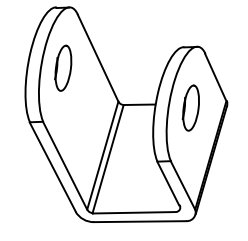

S3 x4

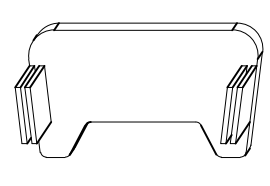

S4 x8

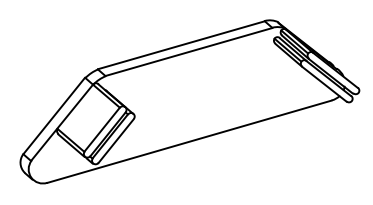

F4 x2

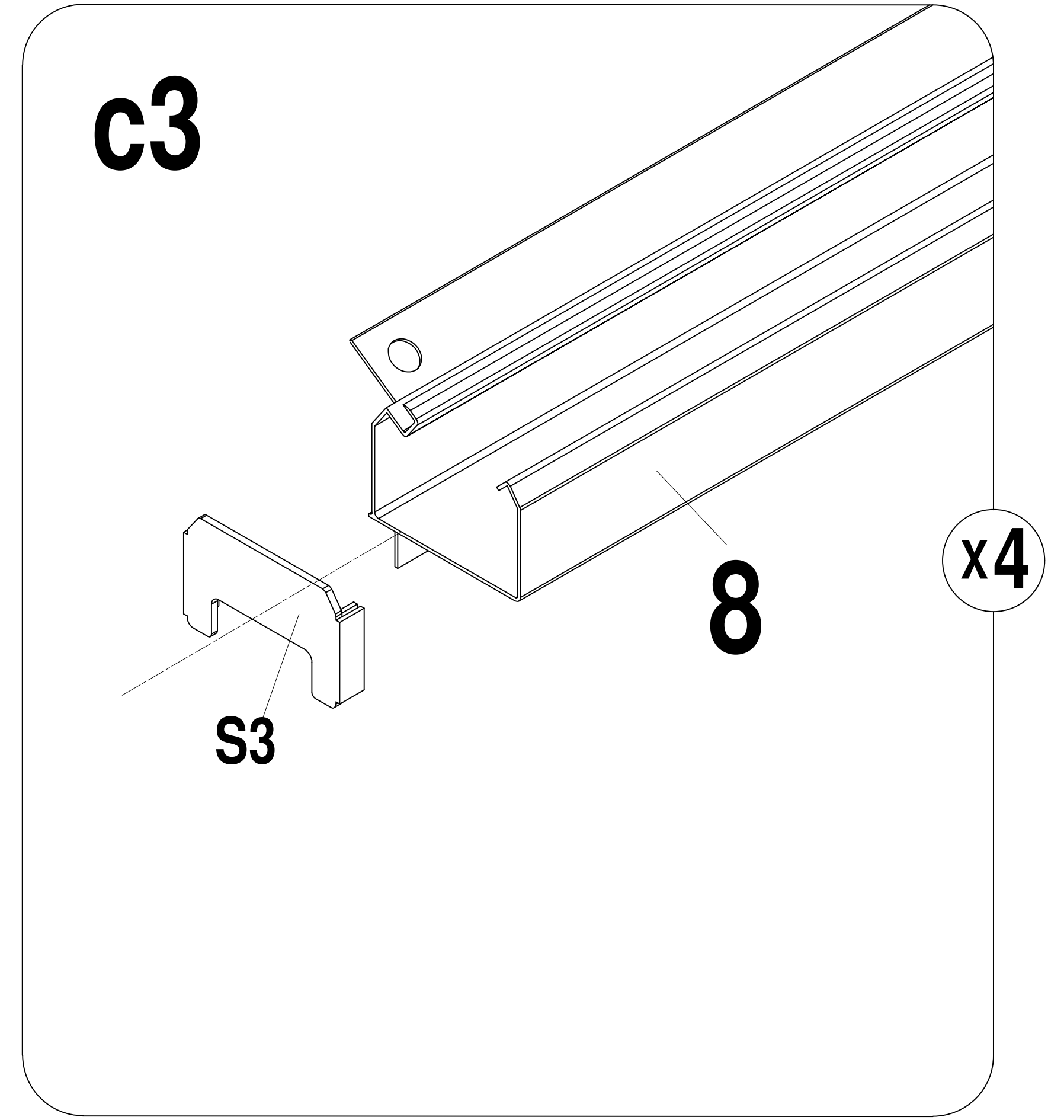
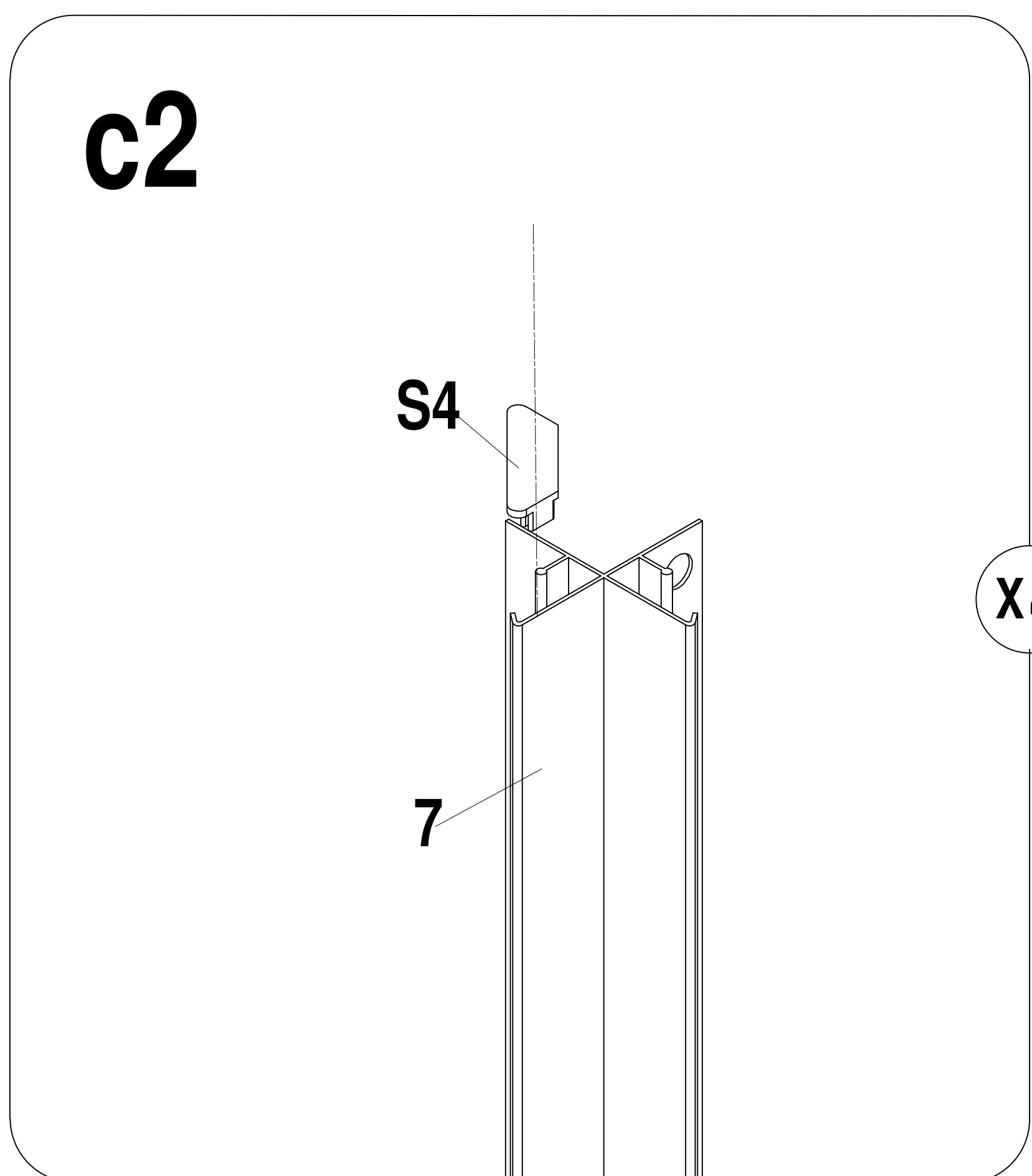
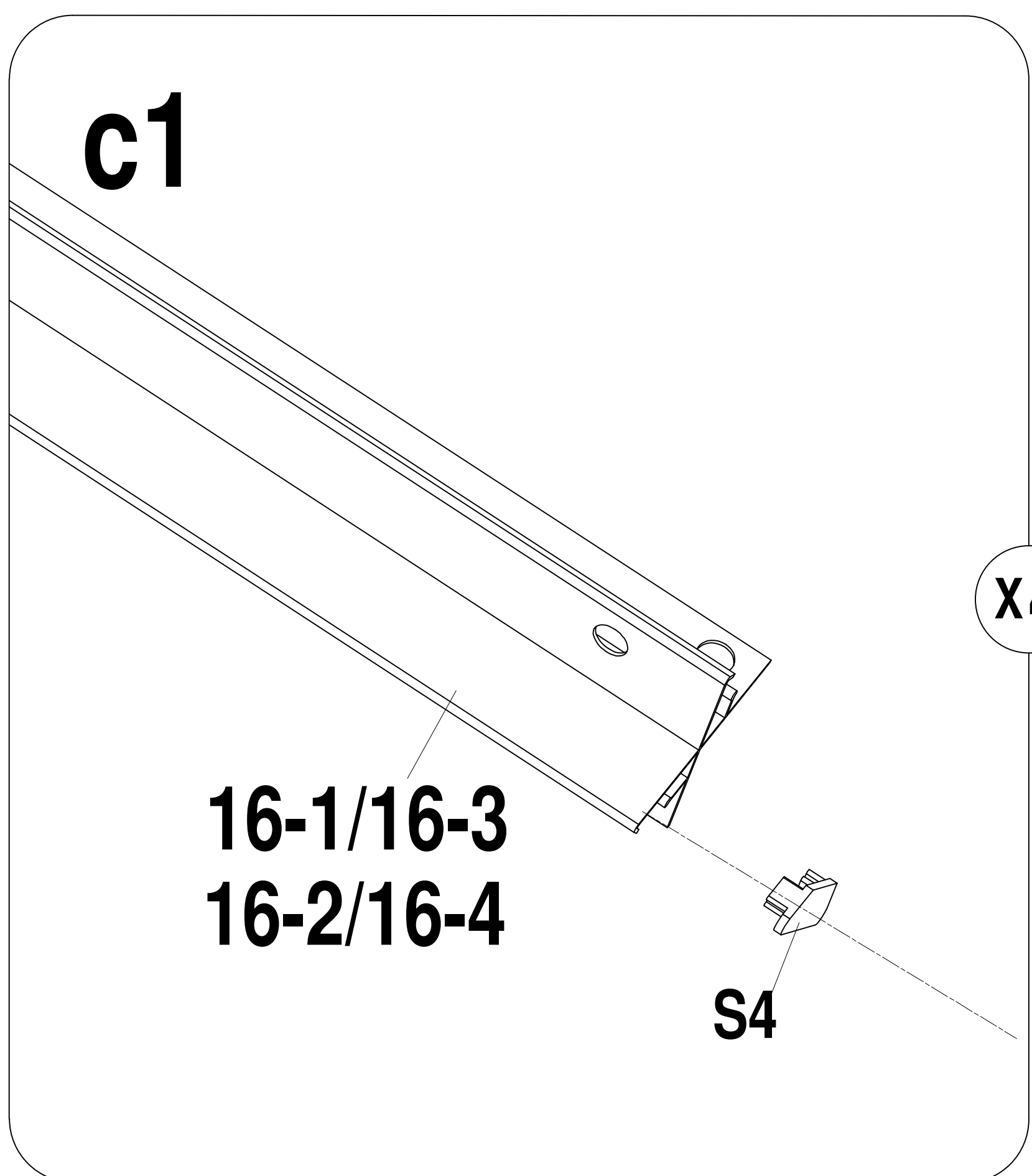
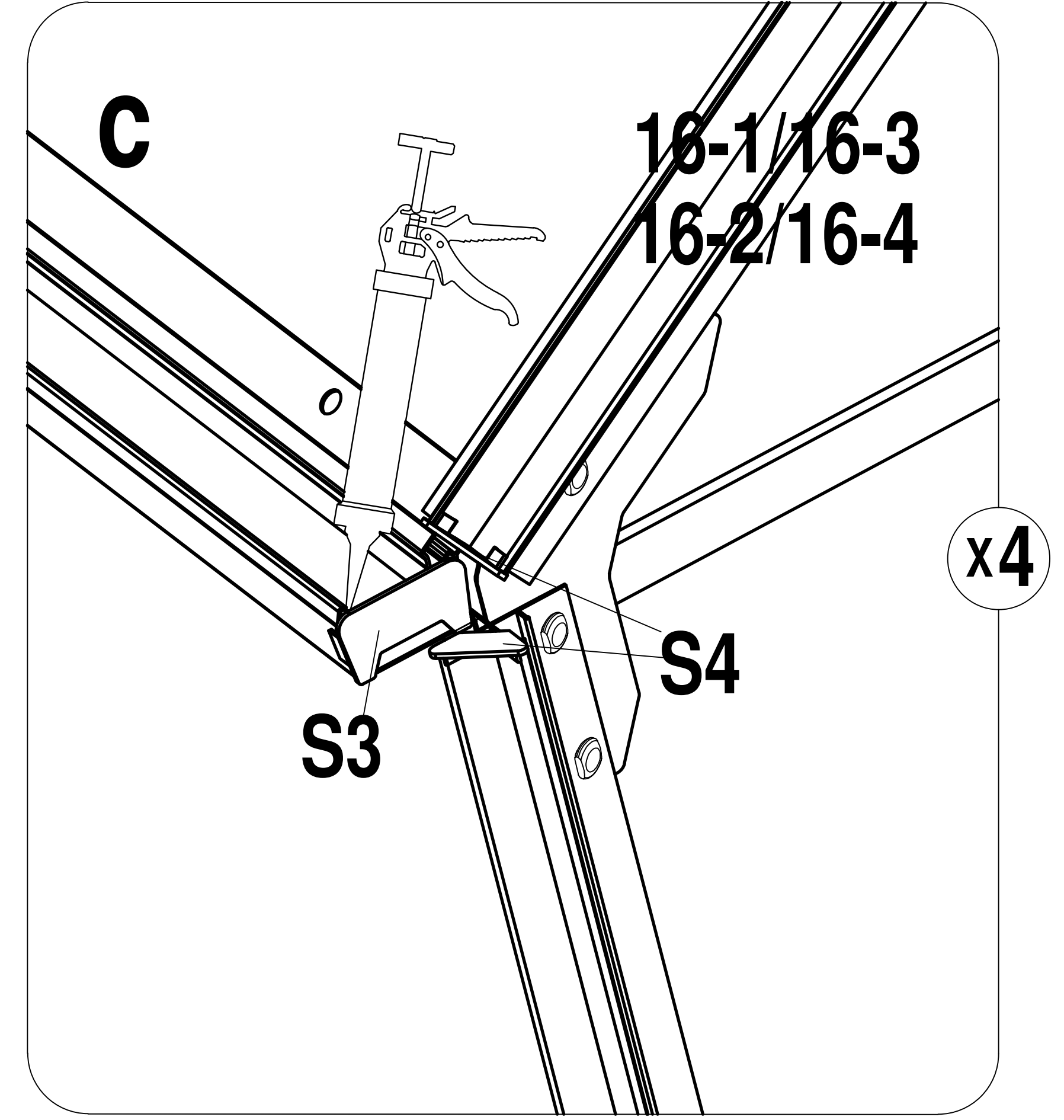
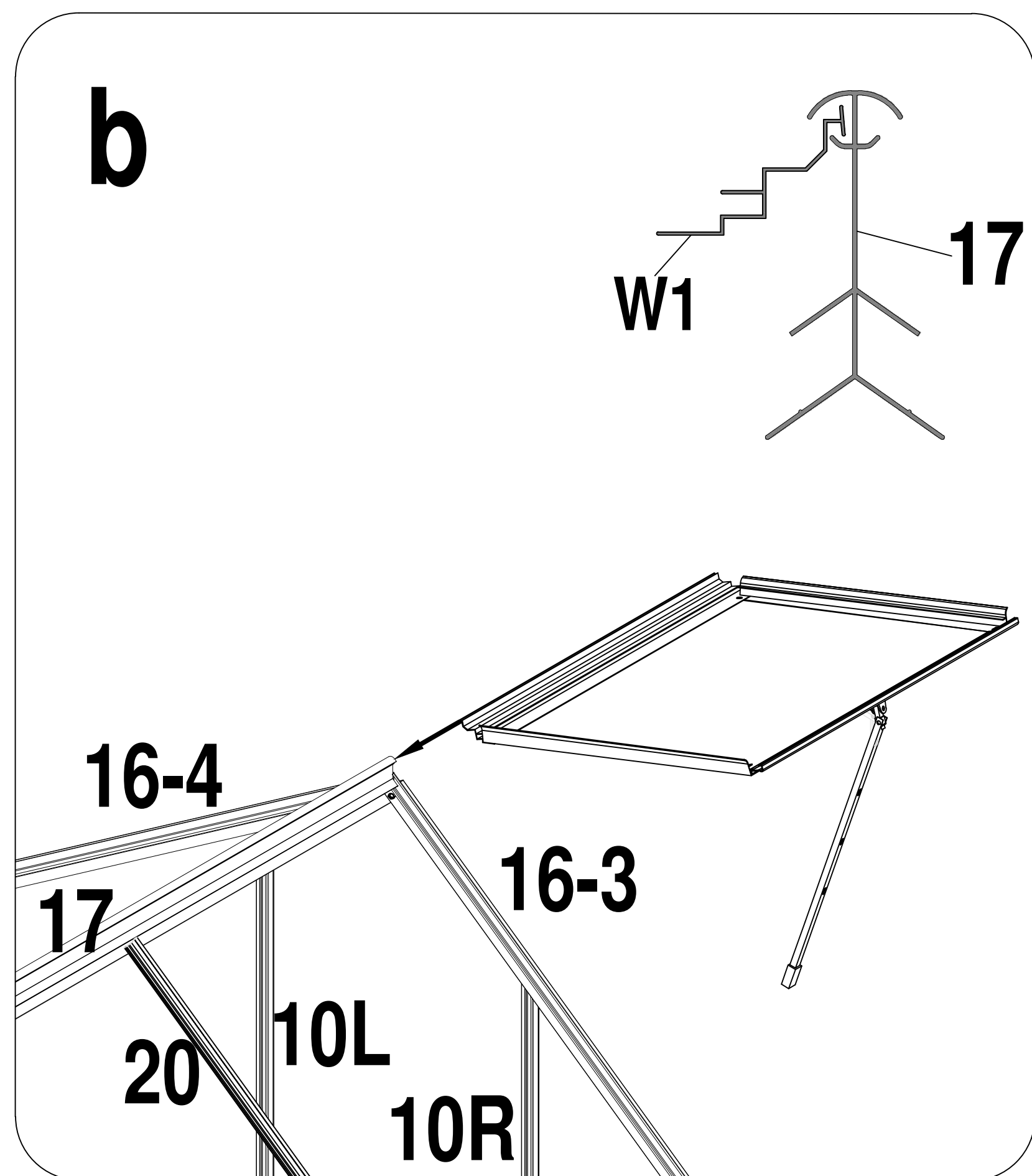
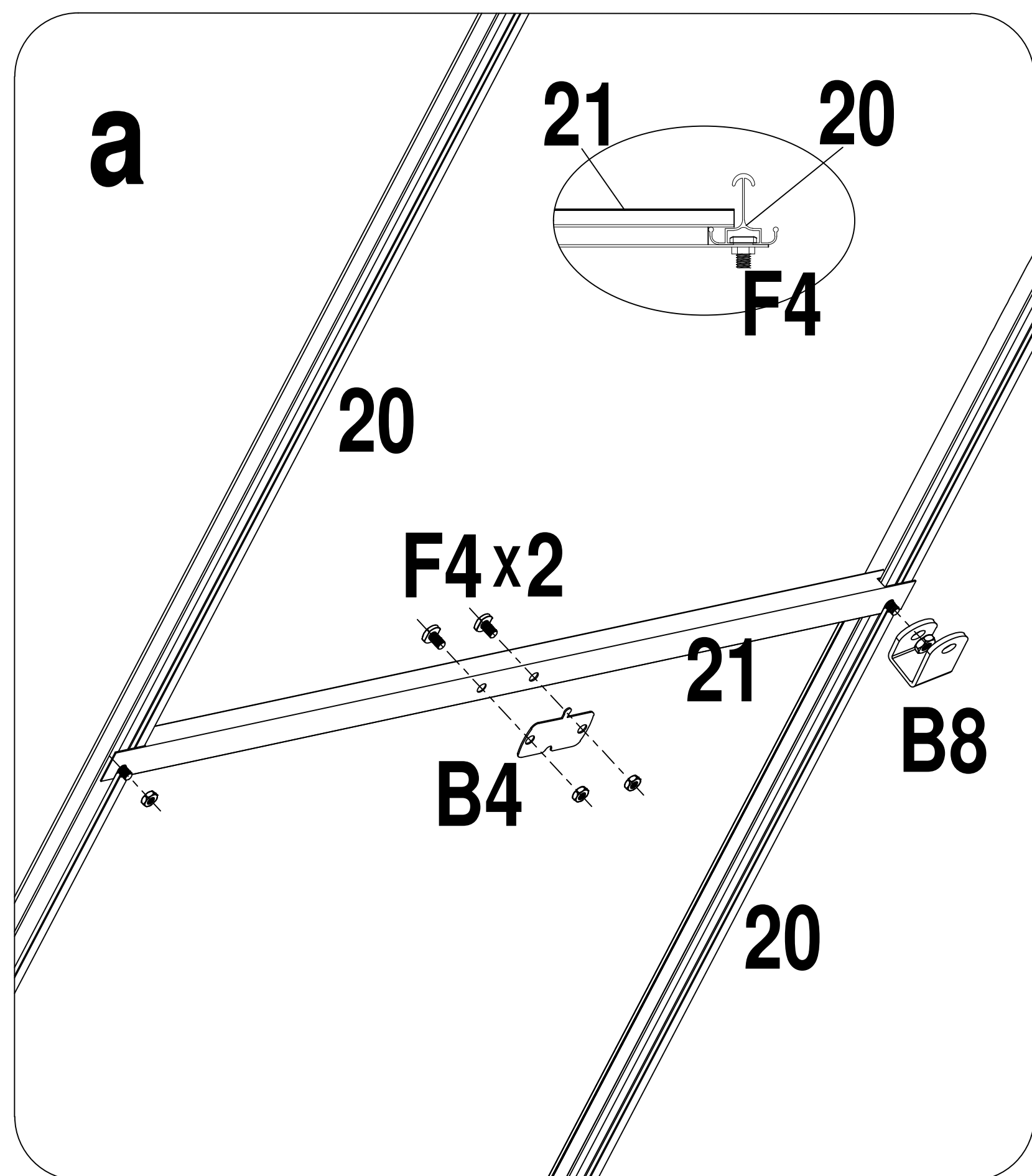
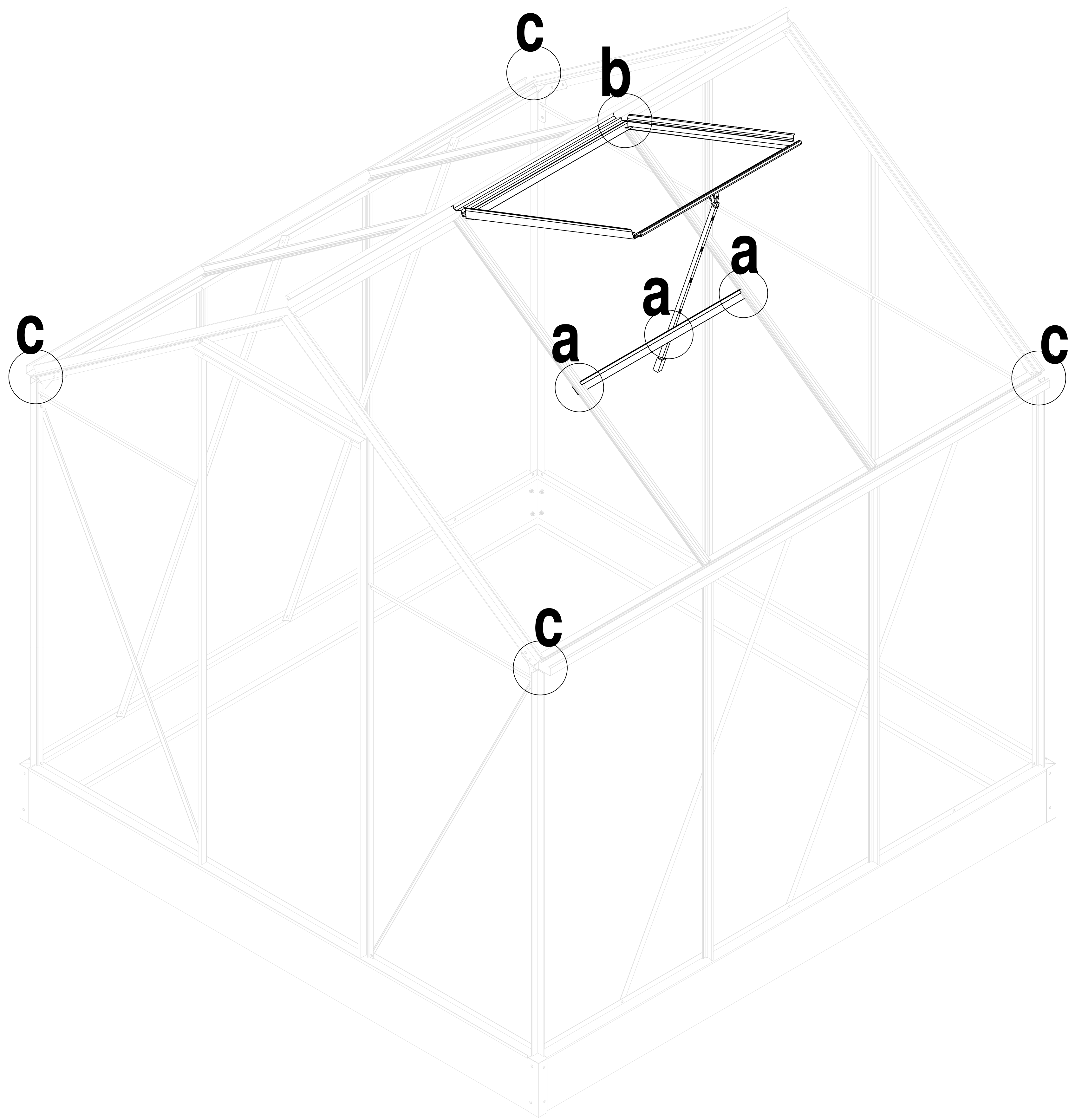
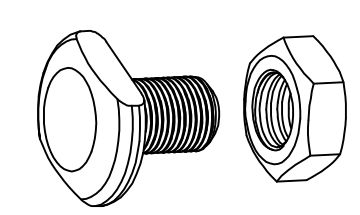

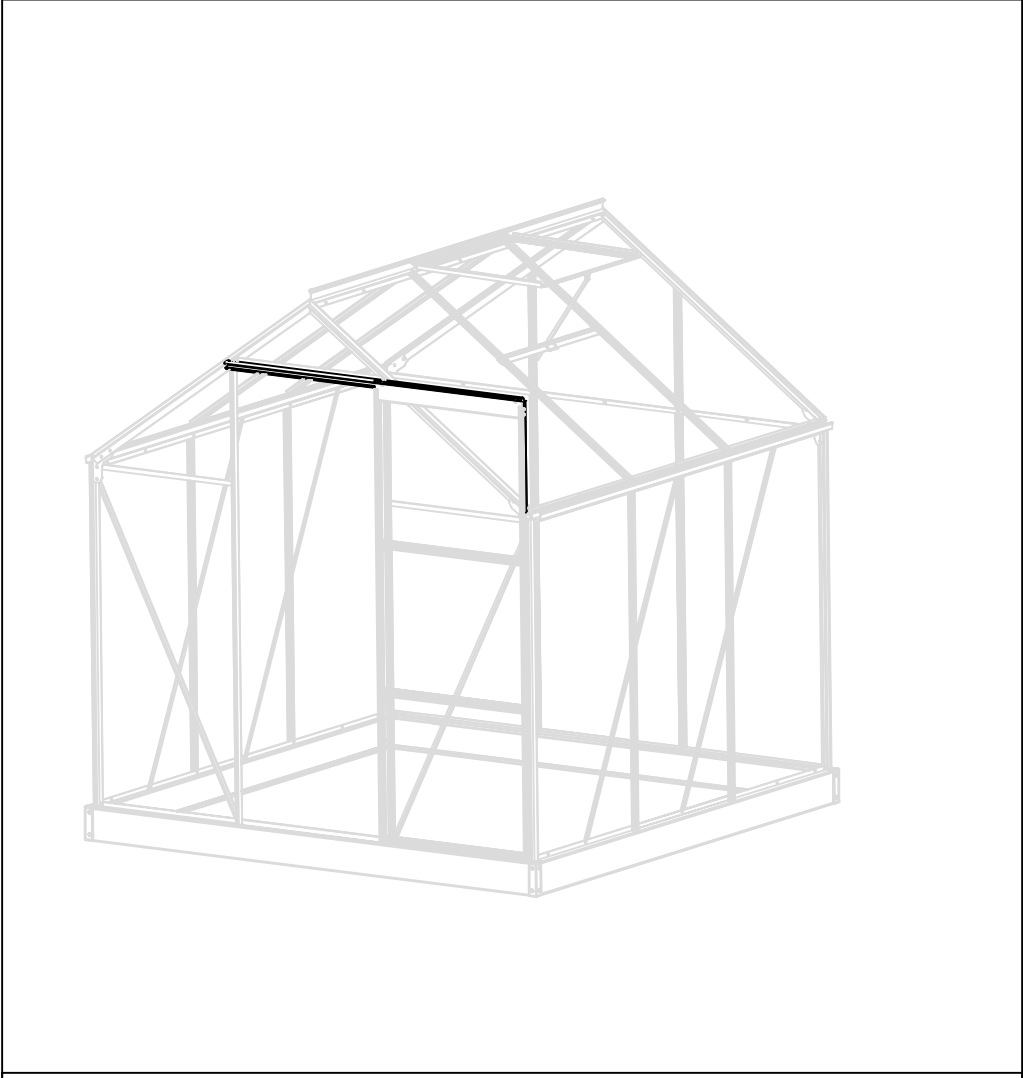

18 x1

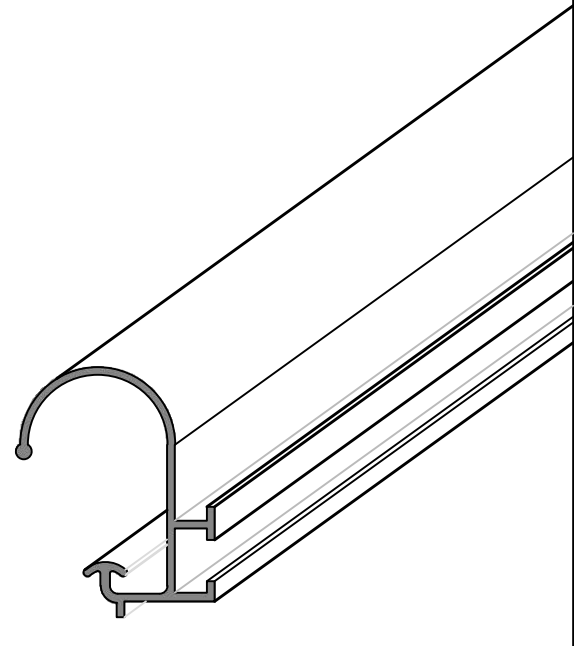

25 x1

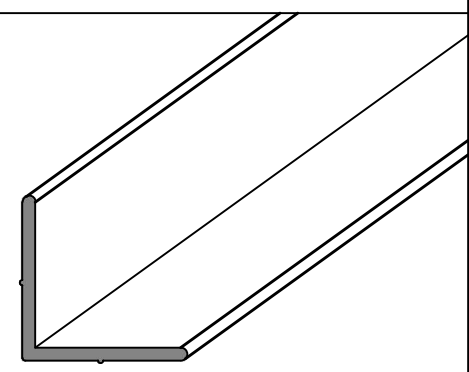

B6 x1

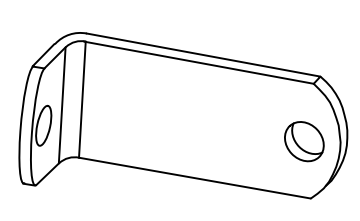

S7R x1

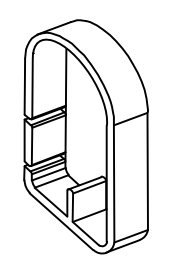

F3 x1

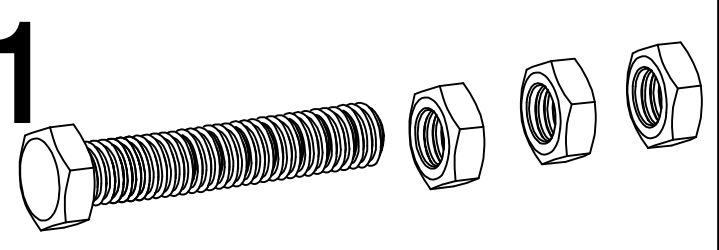

F5 x3

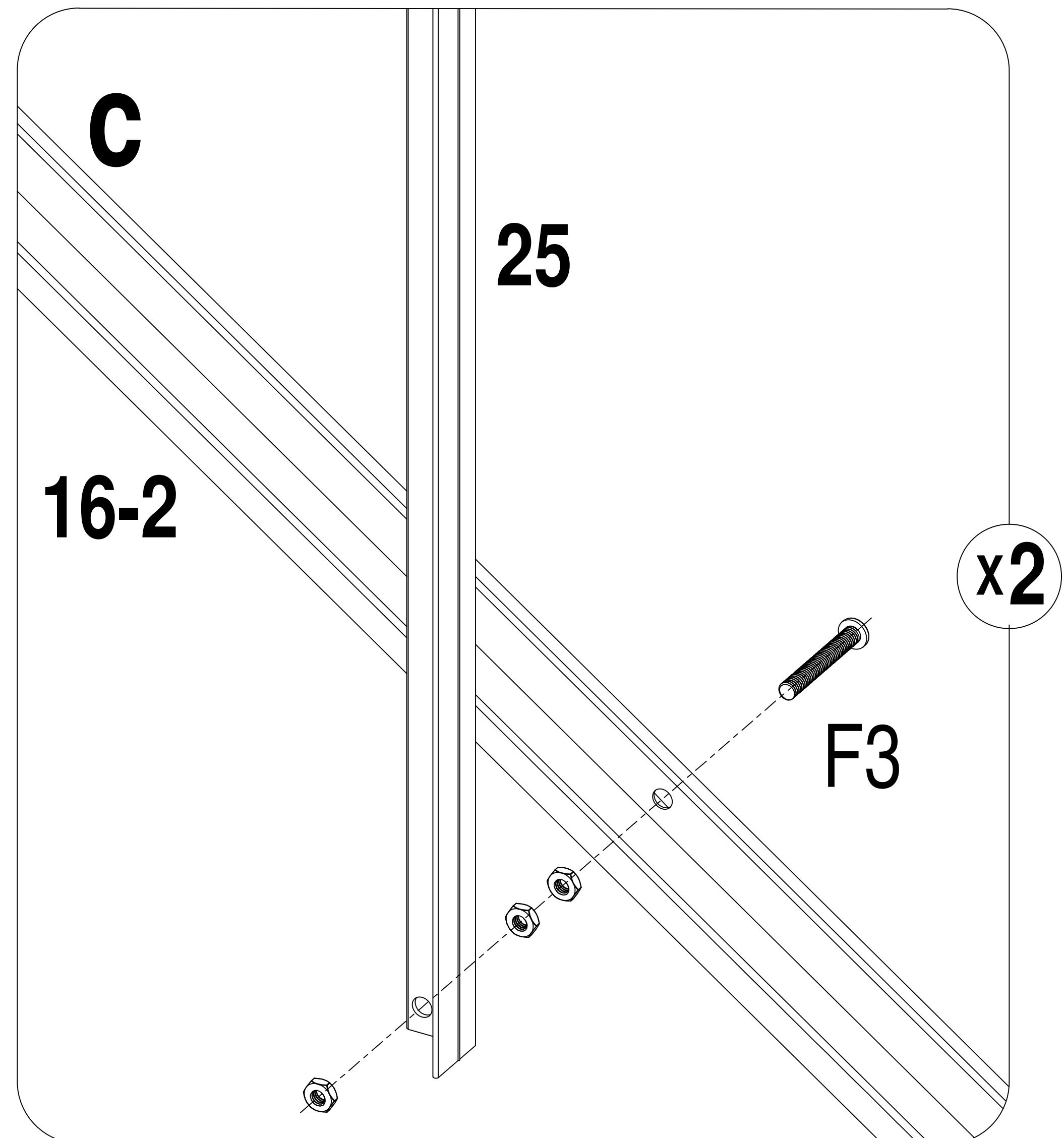
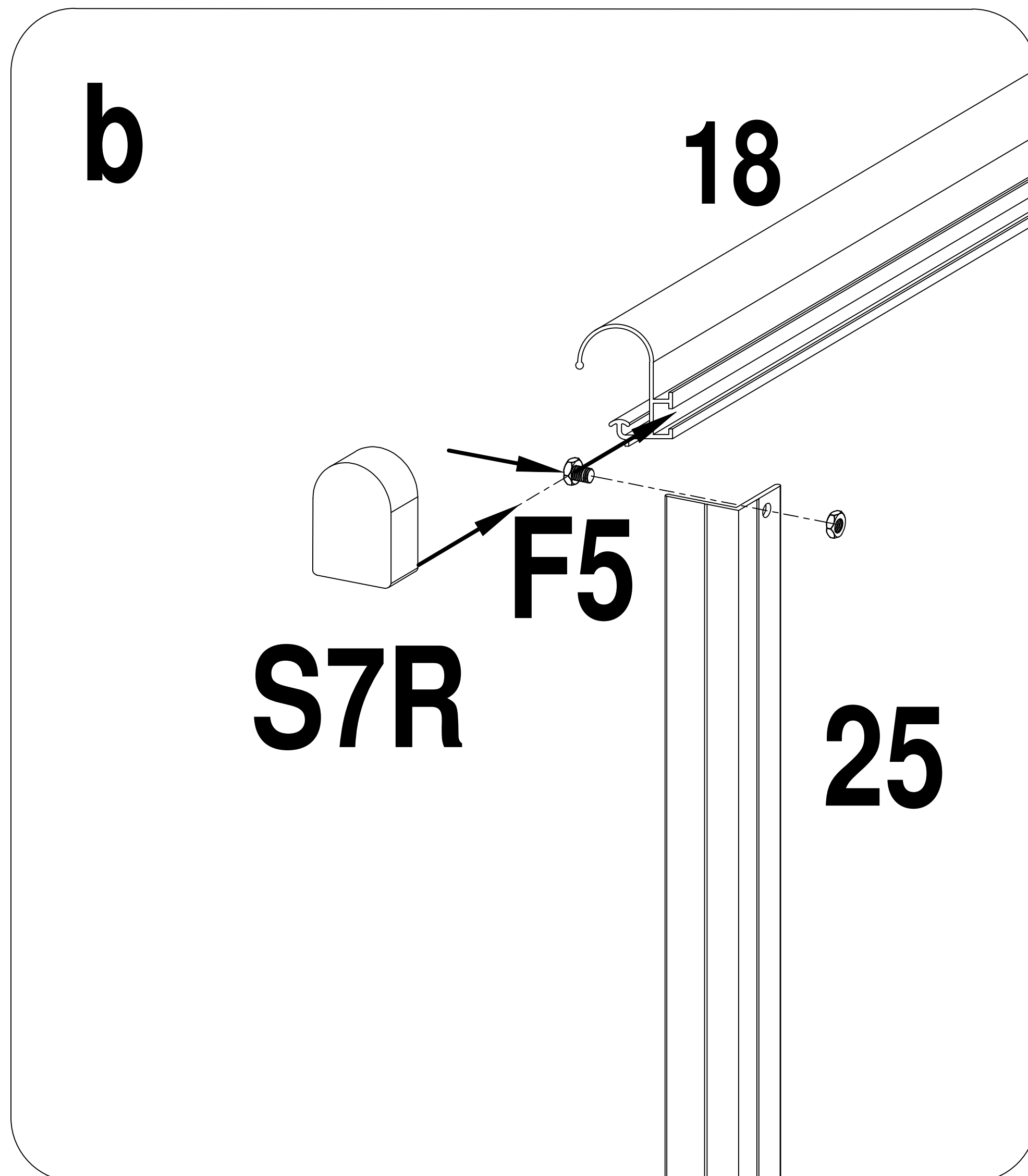
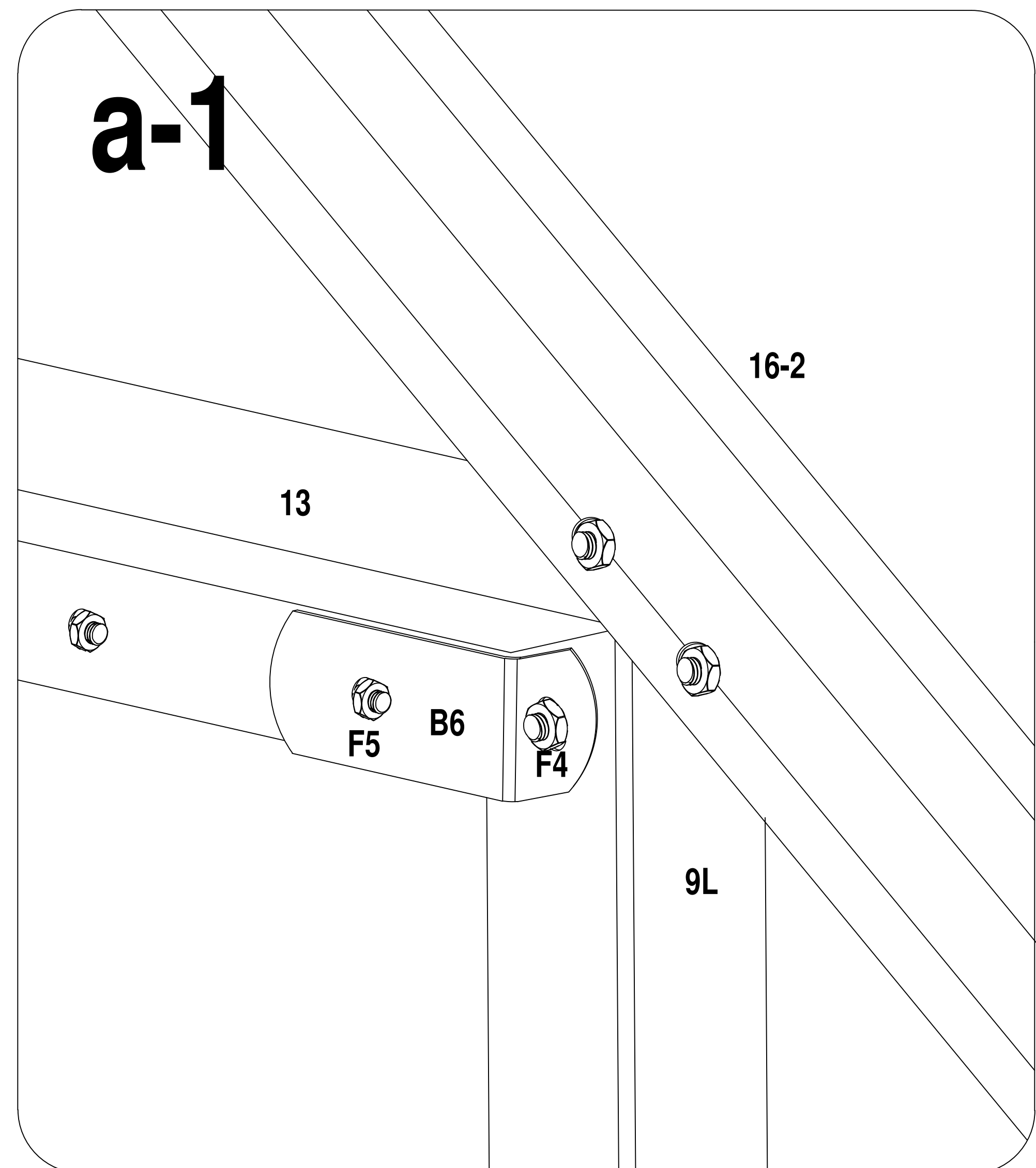
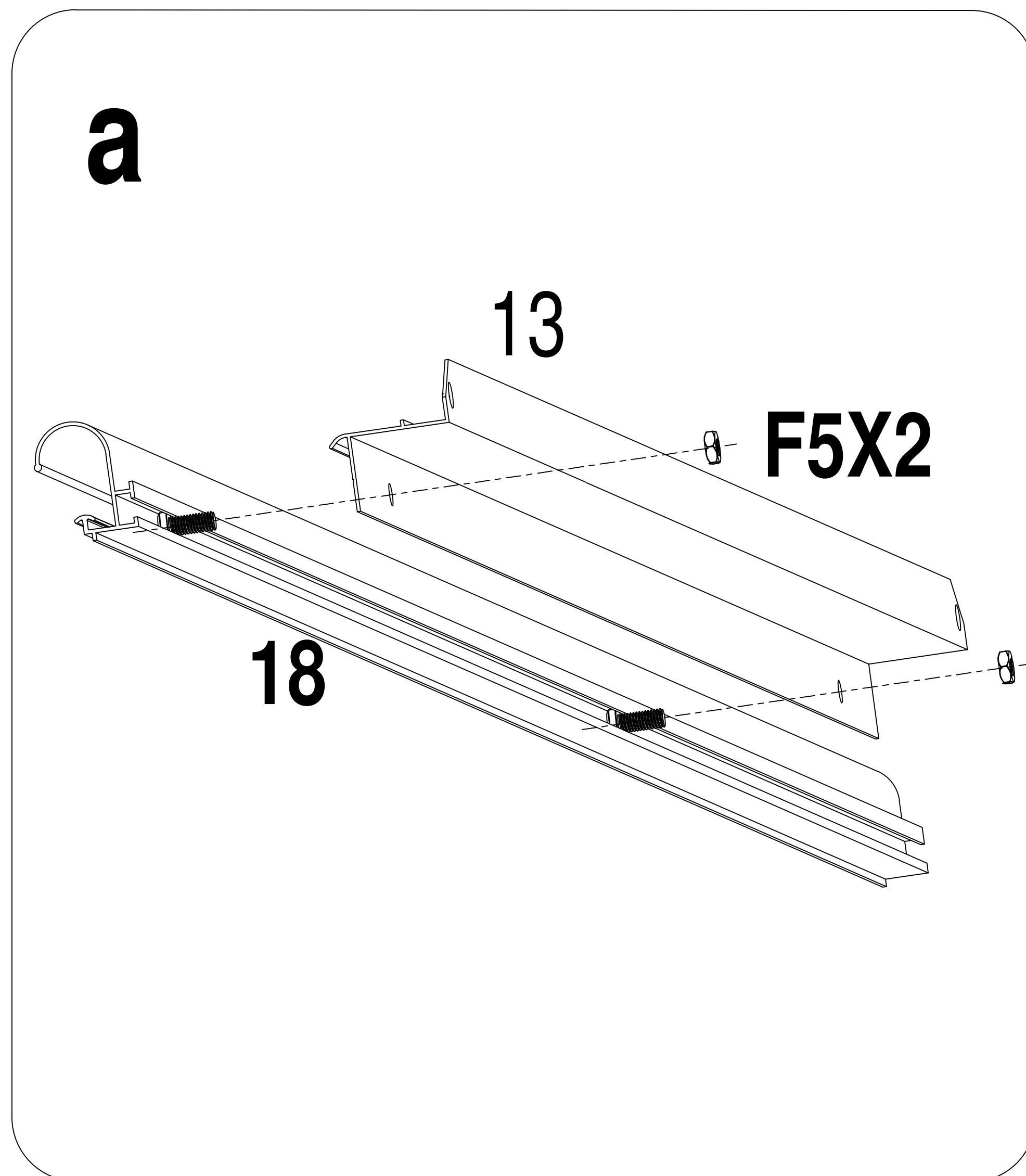
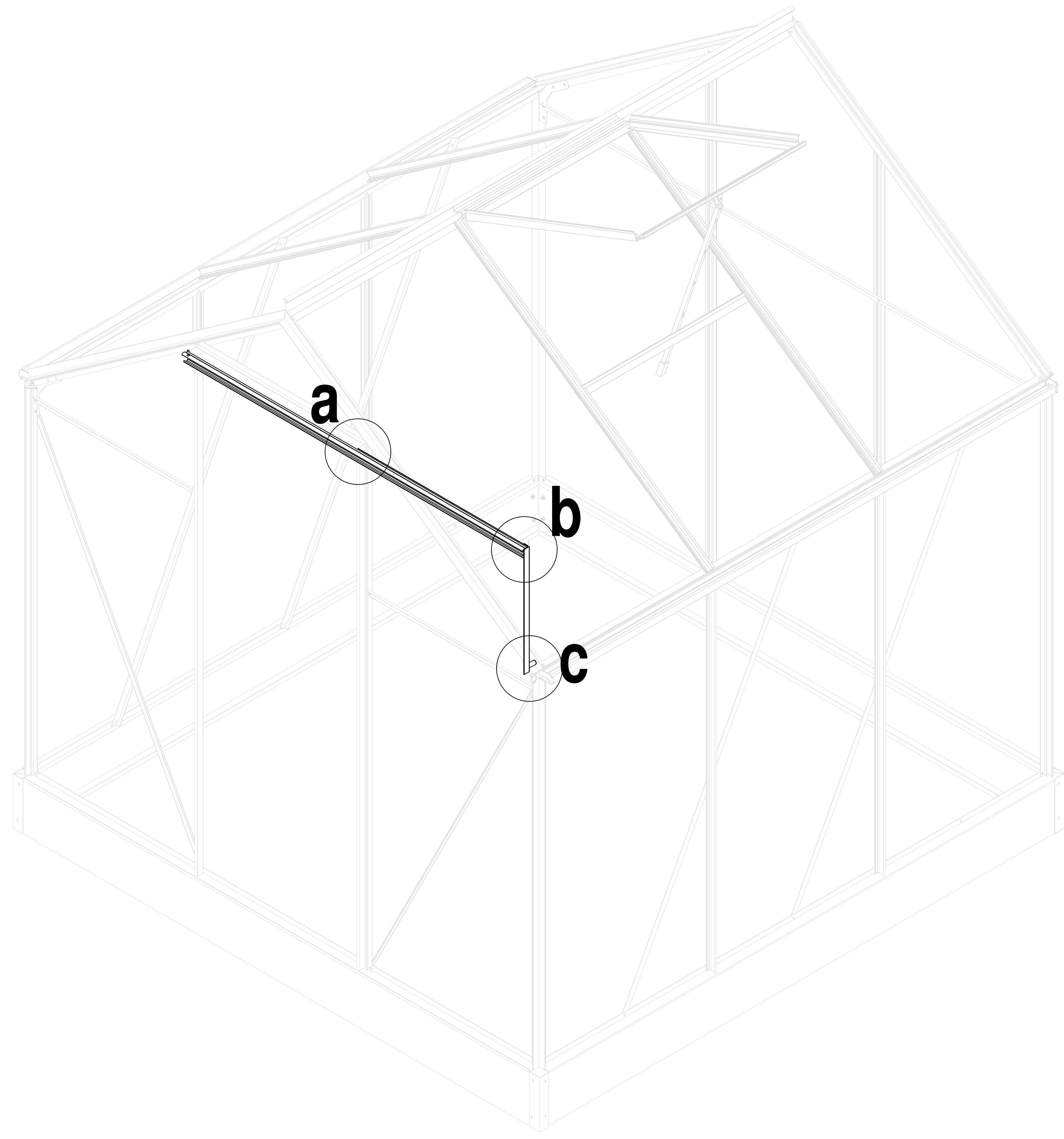
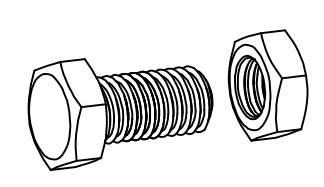

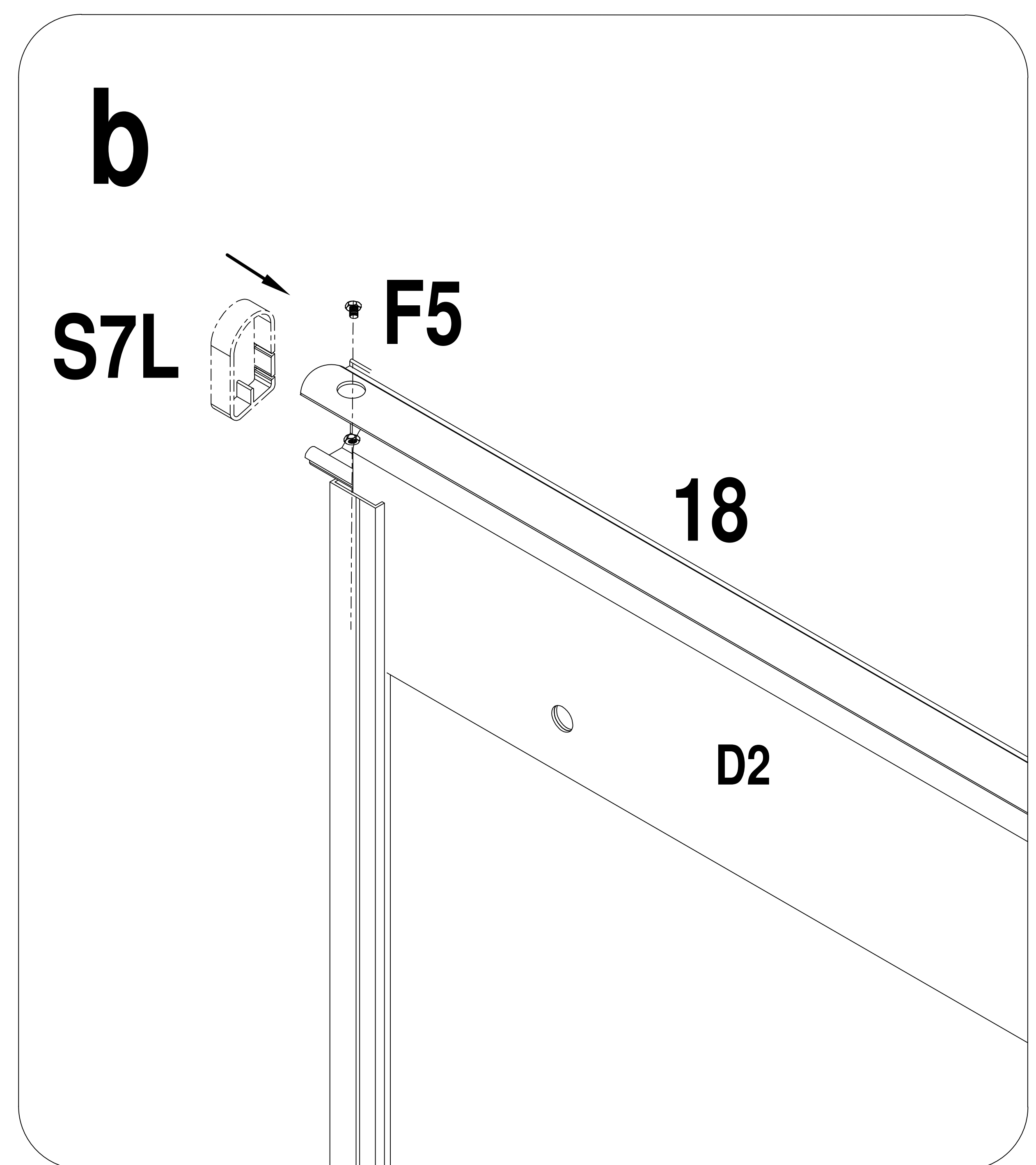
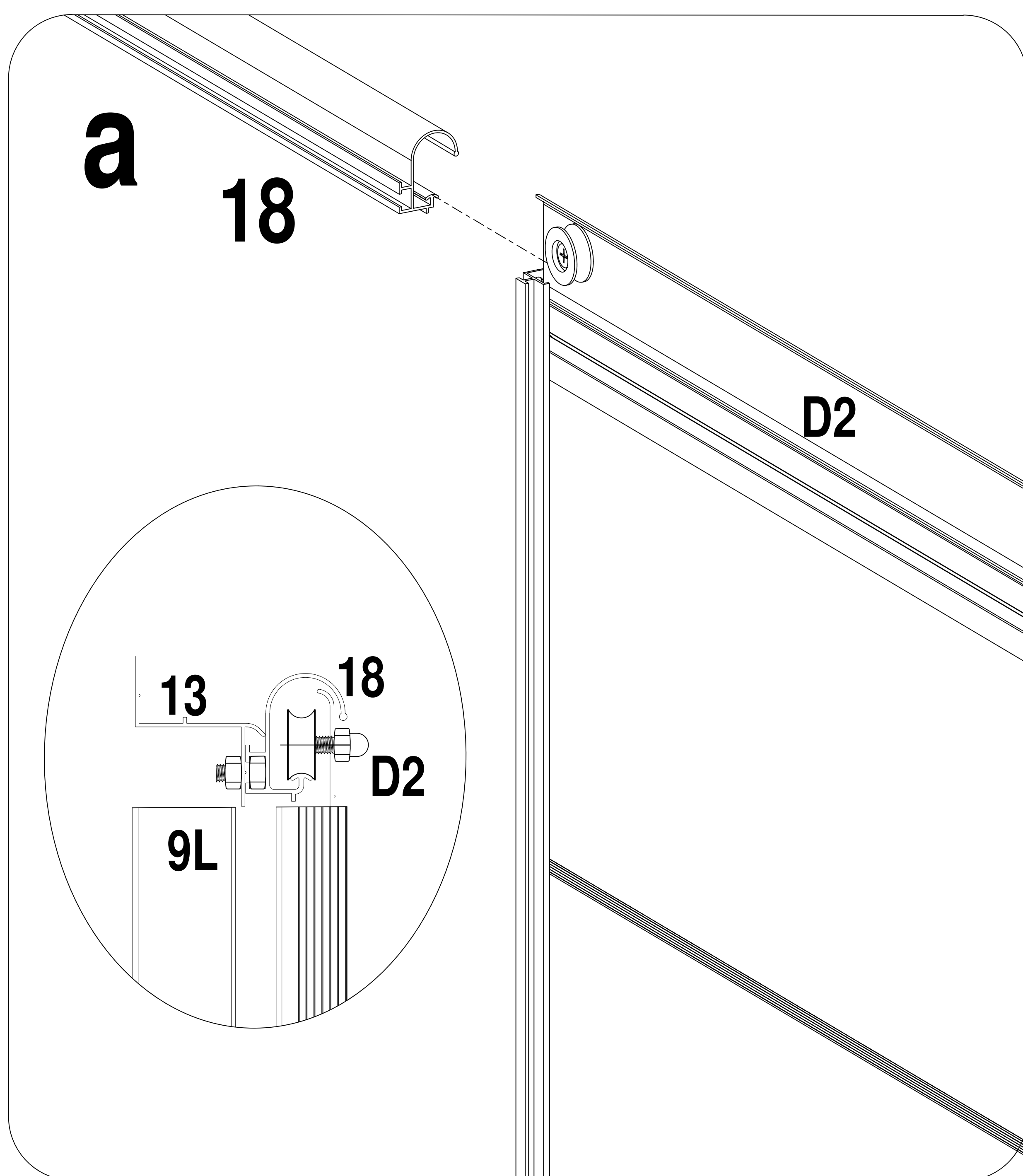
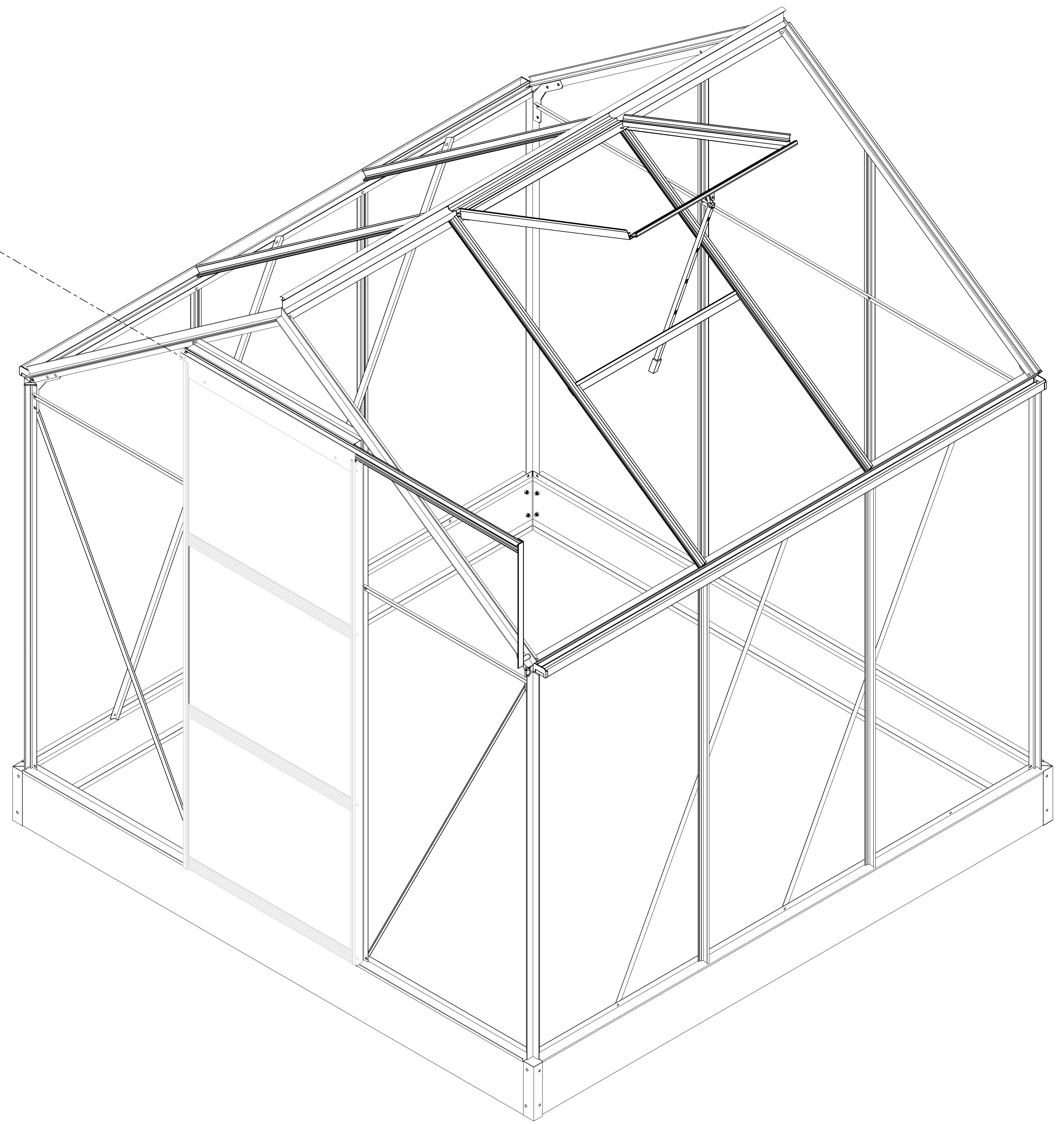
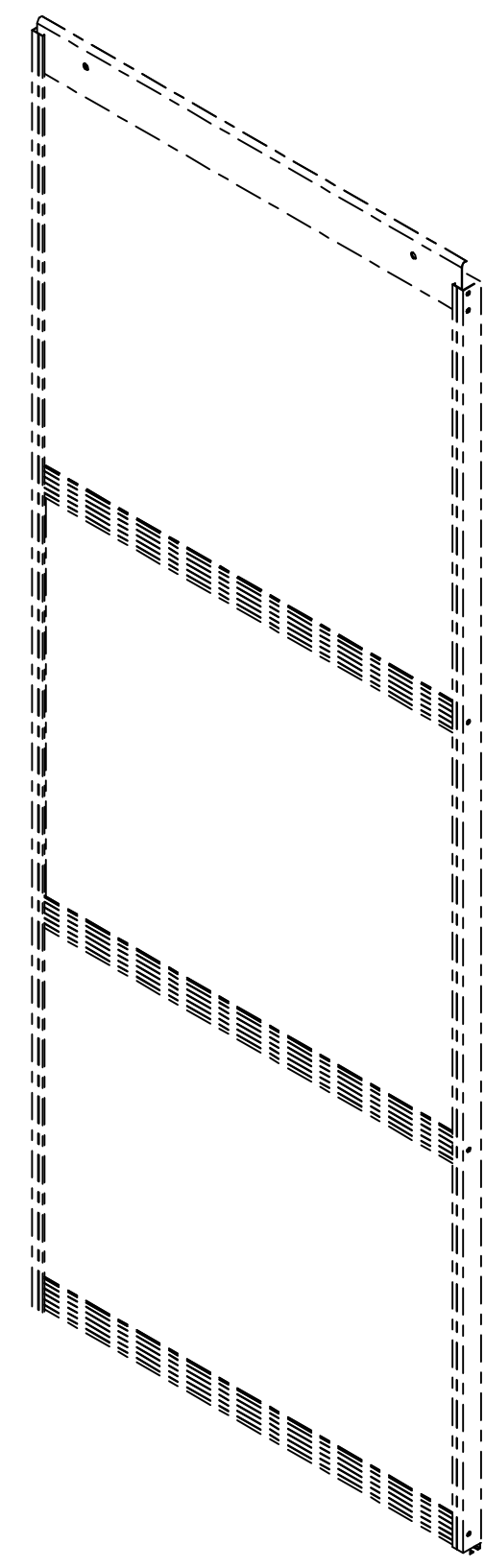
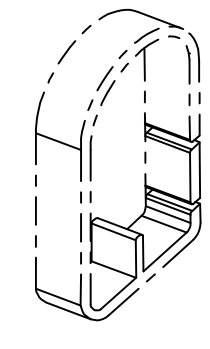
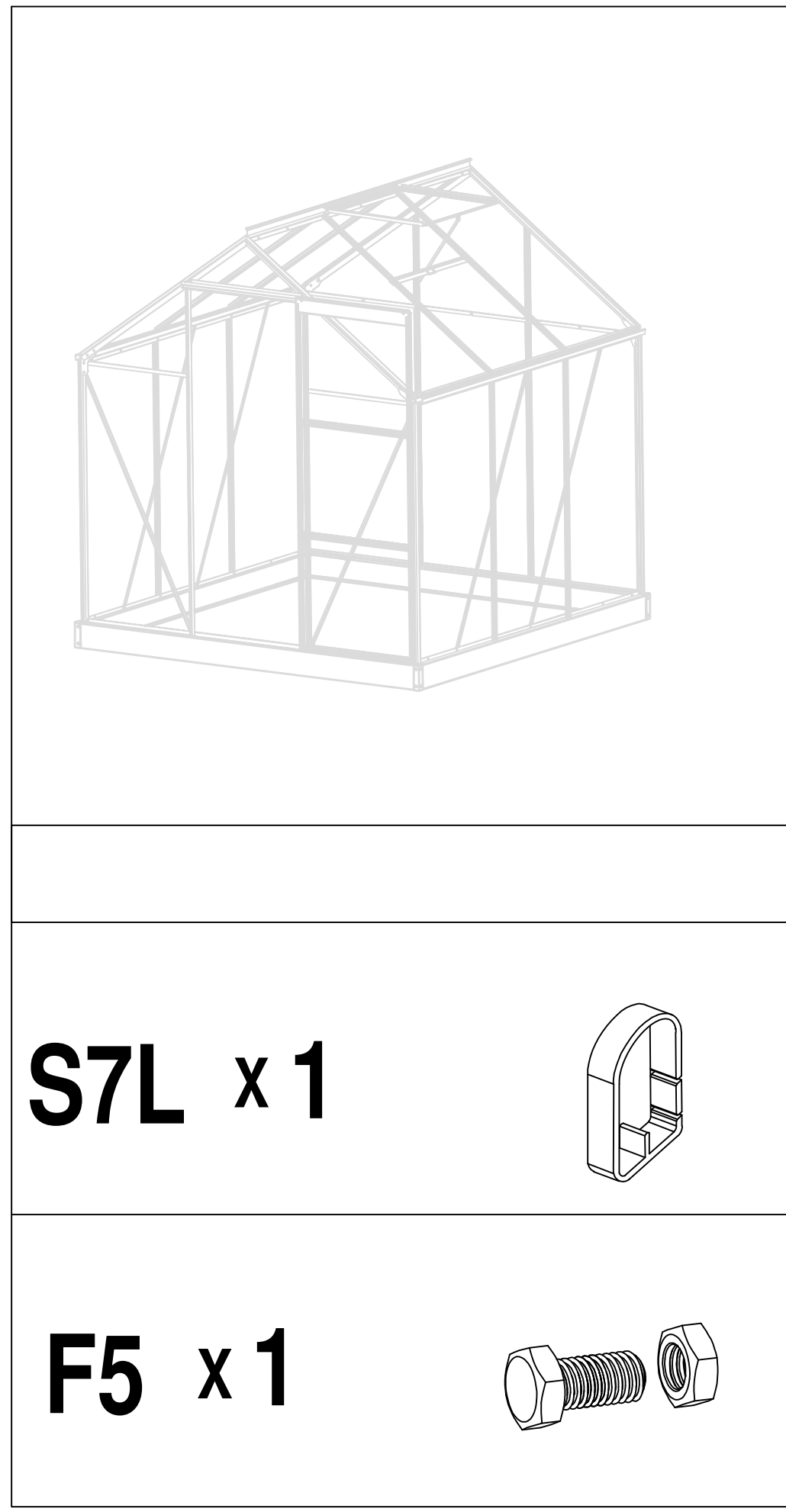

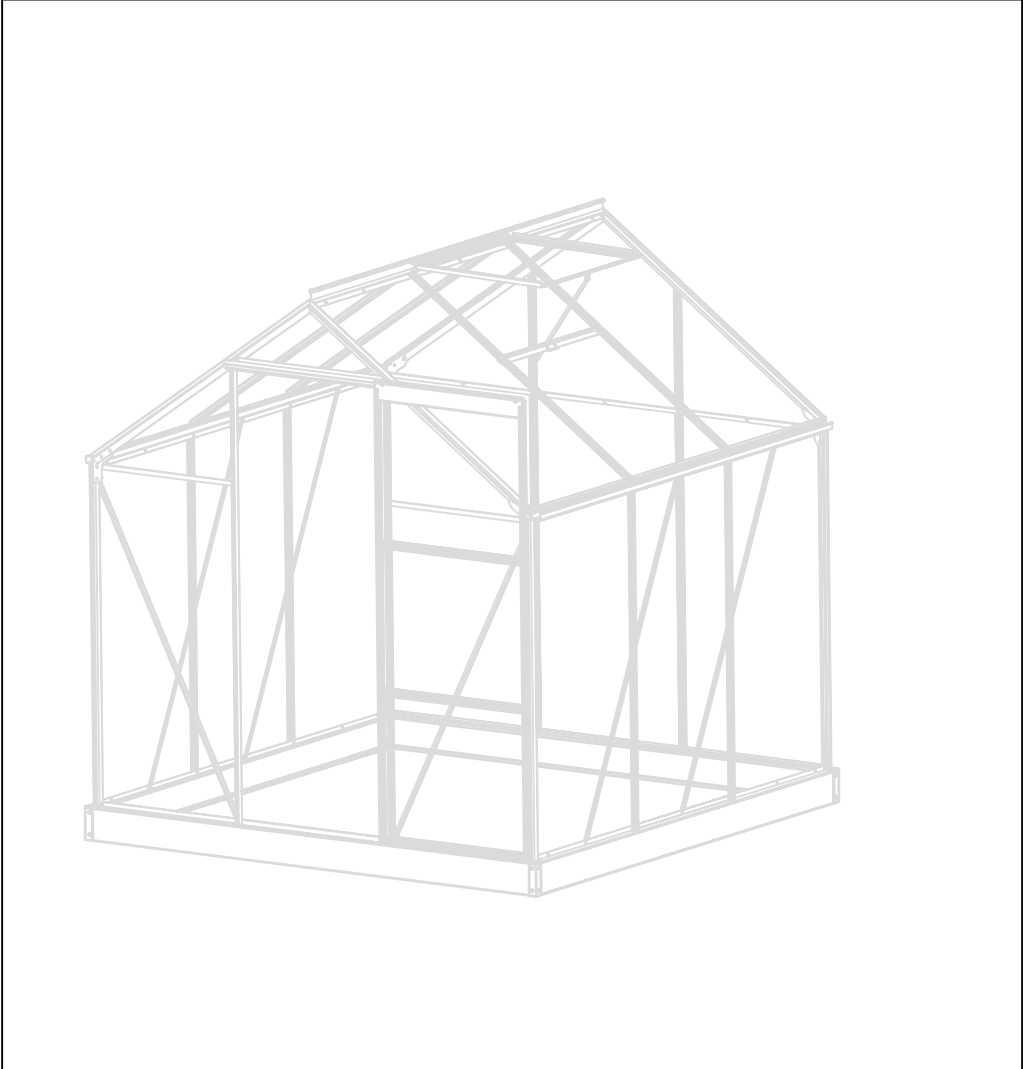

T1 x2

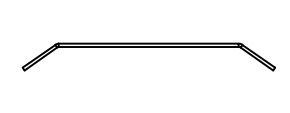

T2 x4

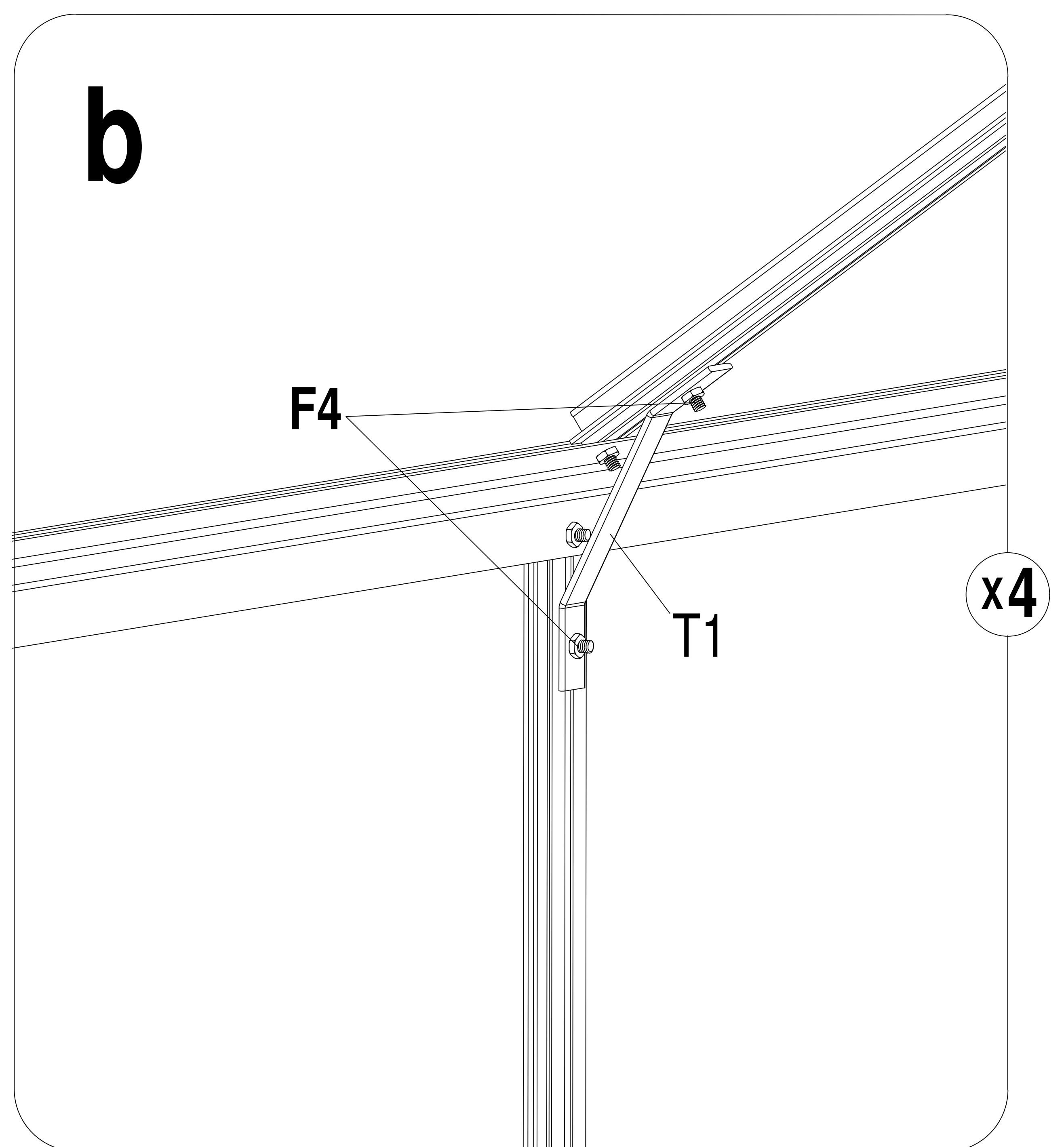
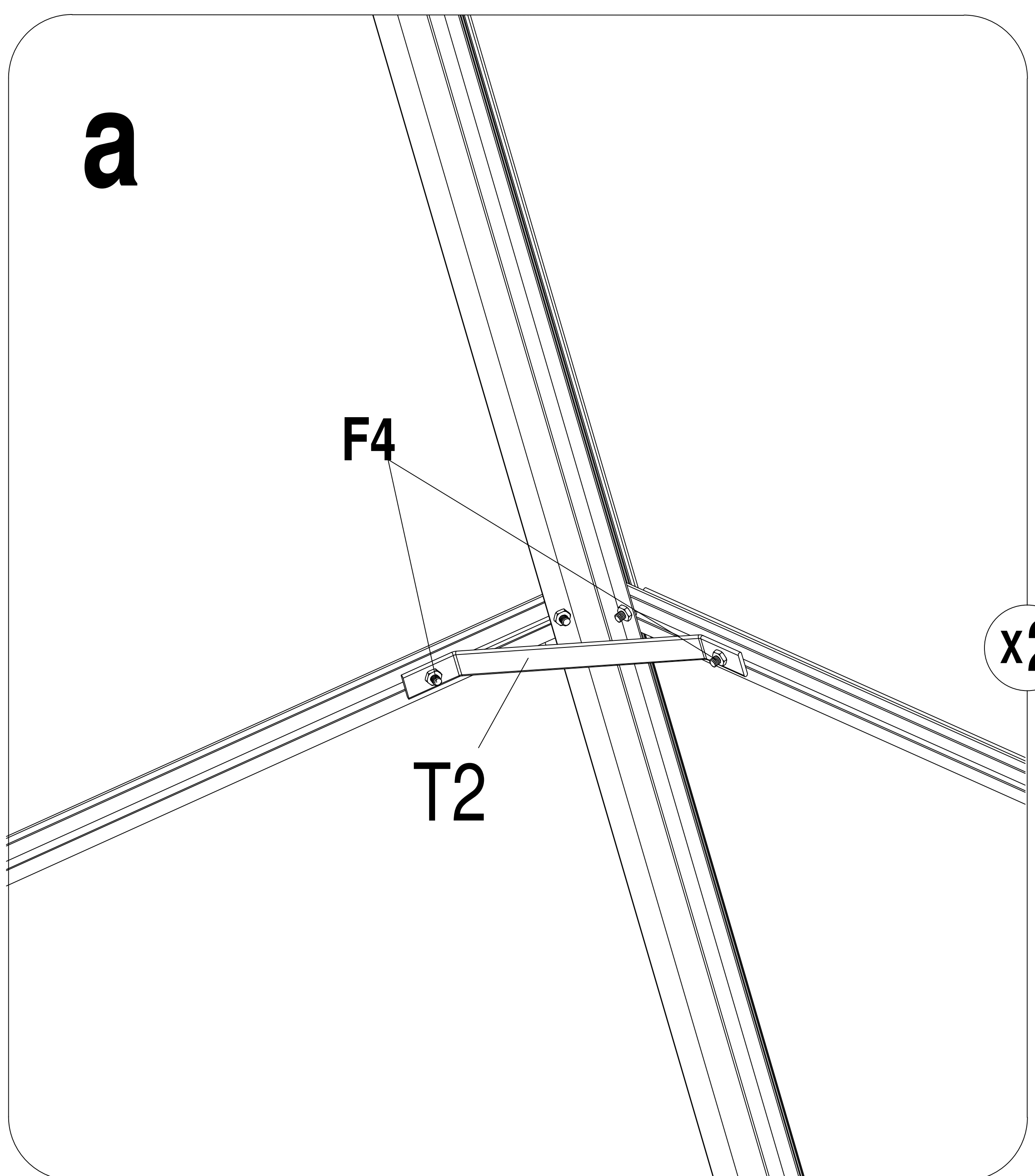
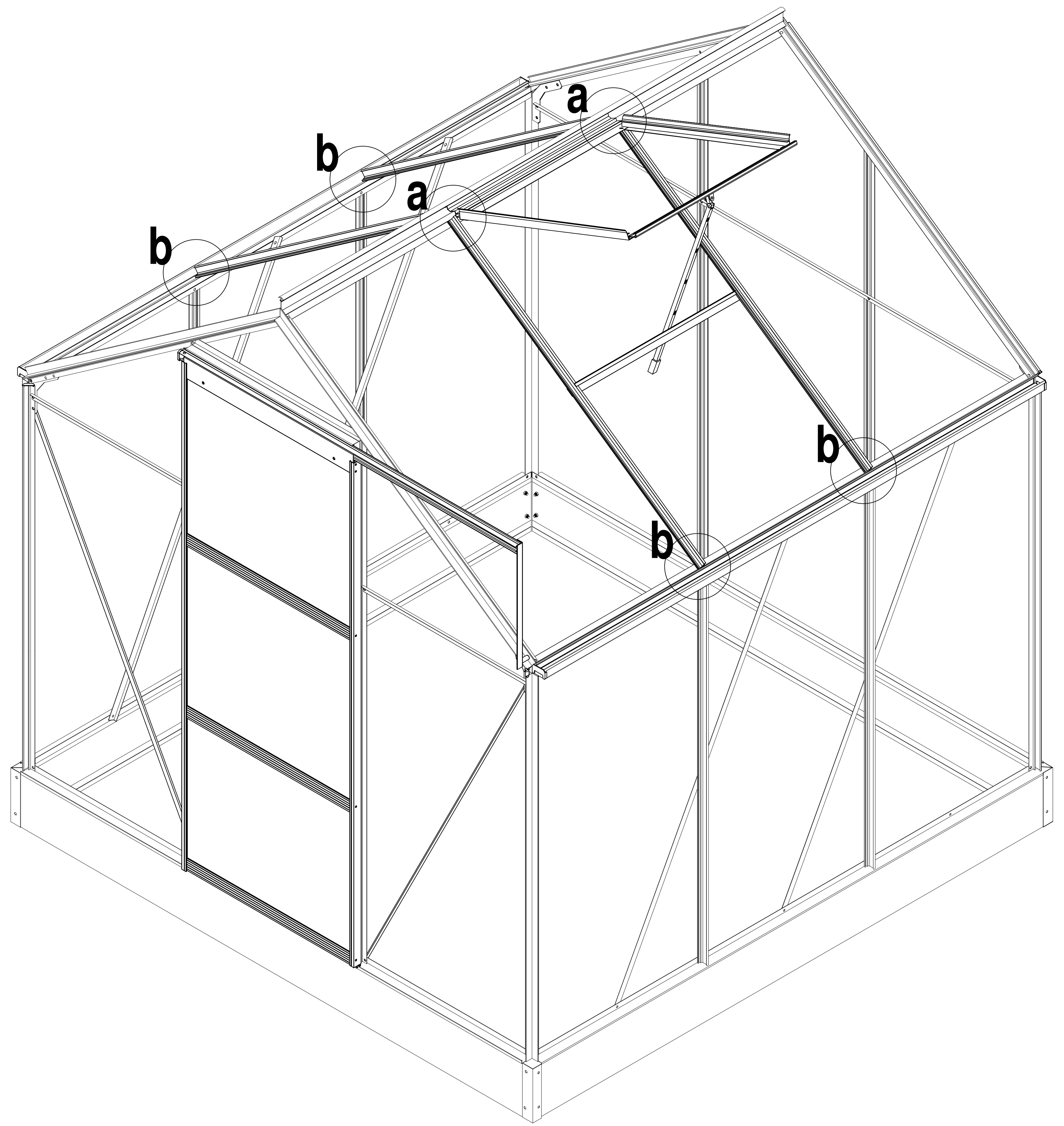
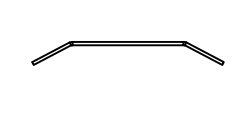

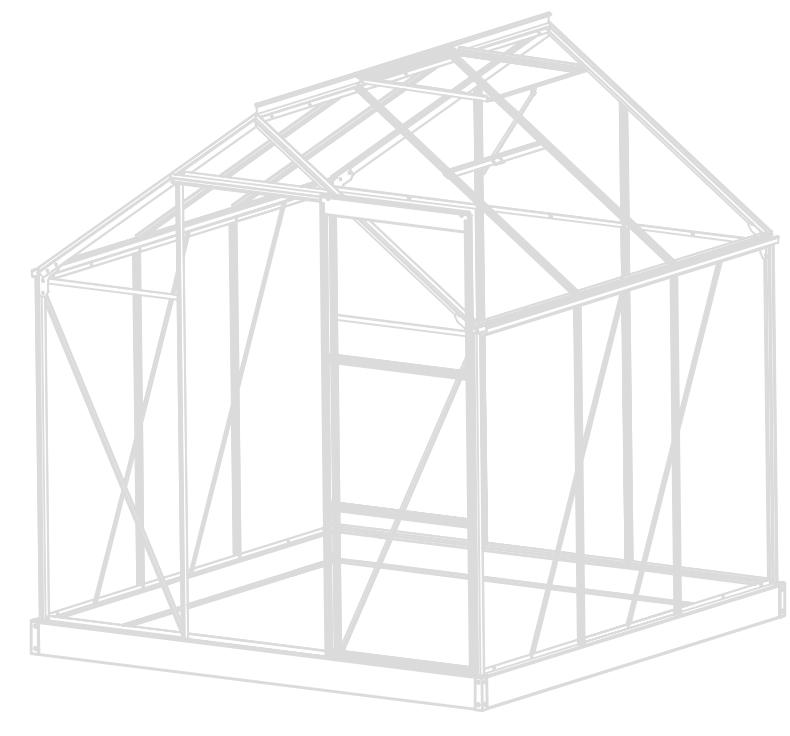
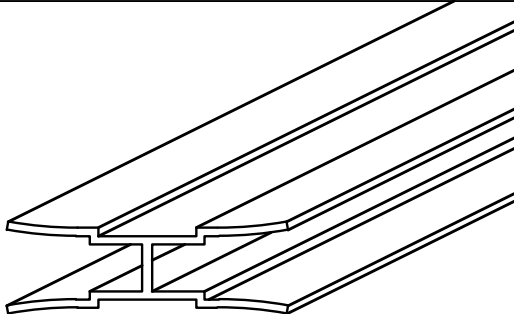
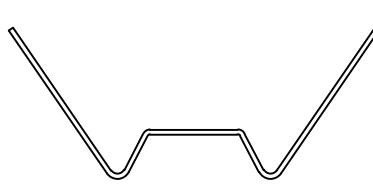
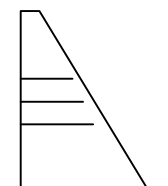
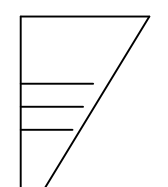
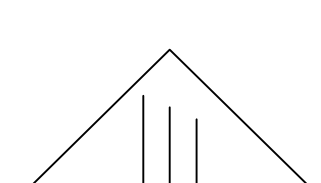
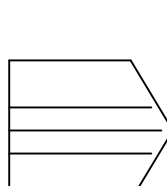
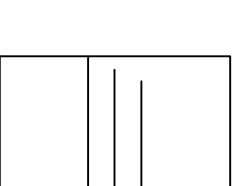
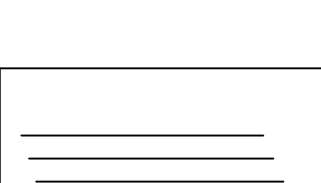
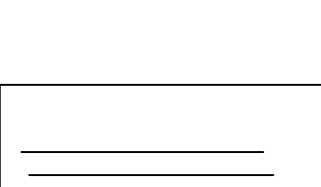

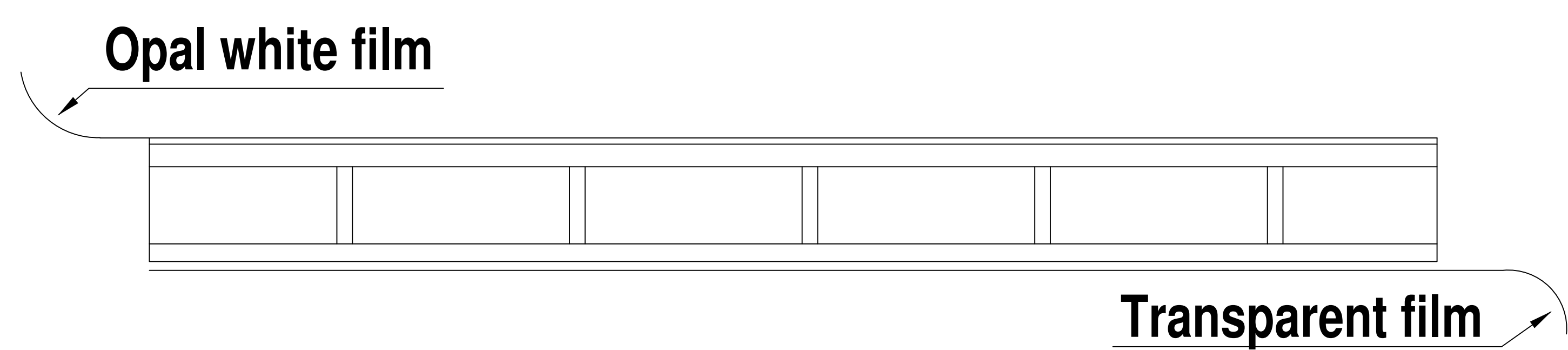
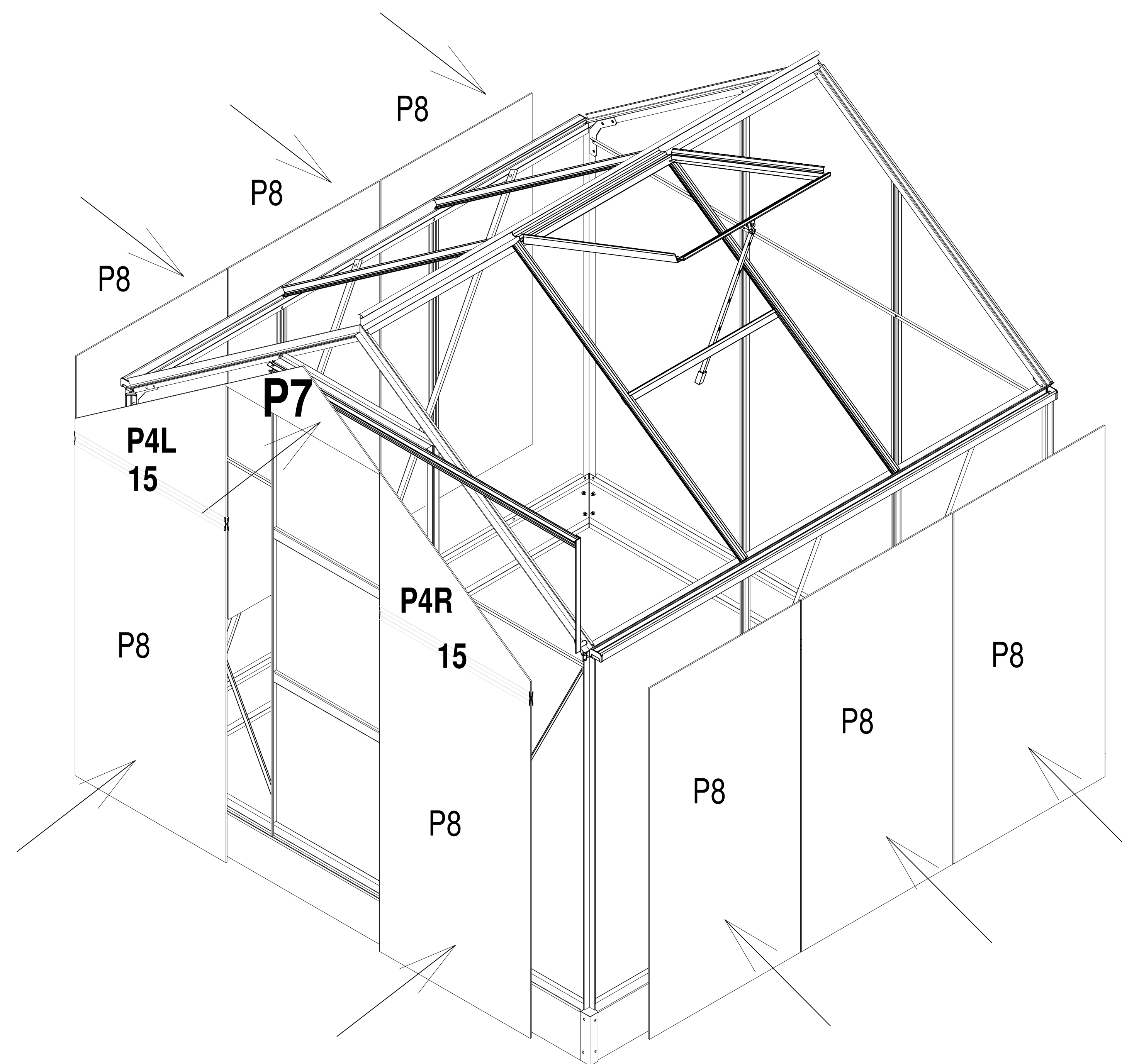
15 x5 
B3 x130 
P4L x2 
P4R x2 
P7 x1 
P6 x1 
P10 x1 
P8 x11 
P9 x5 

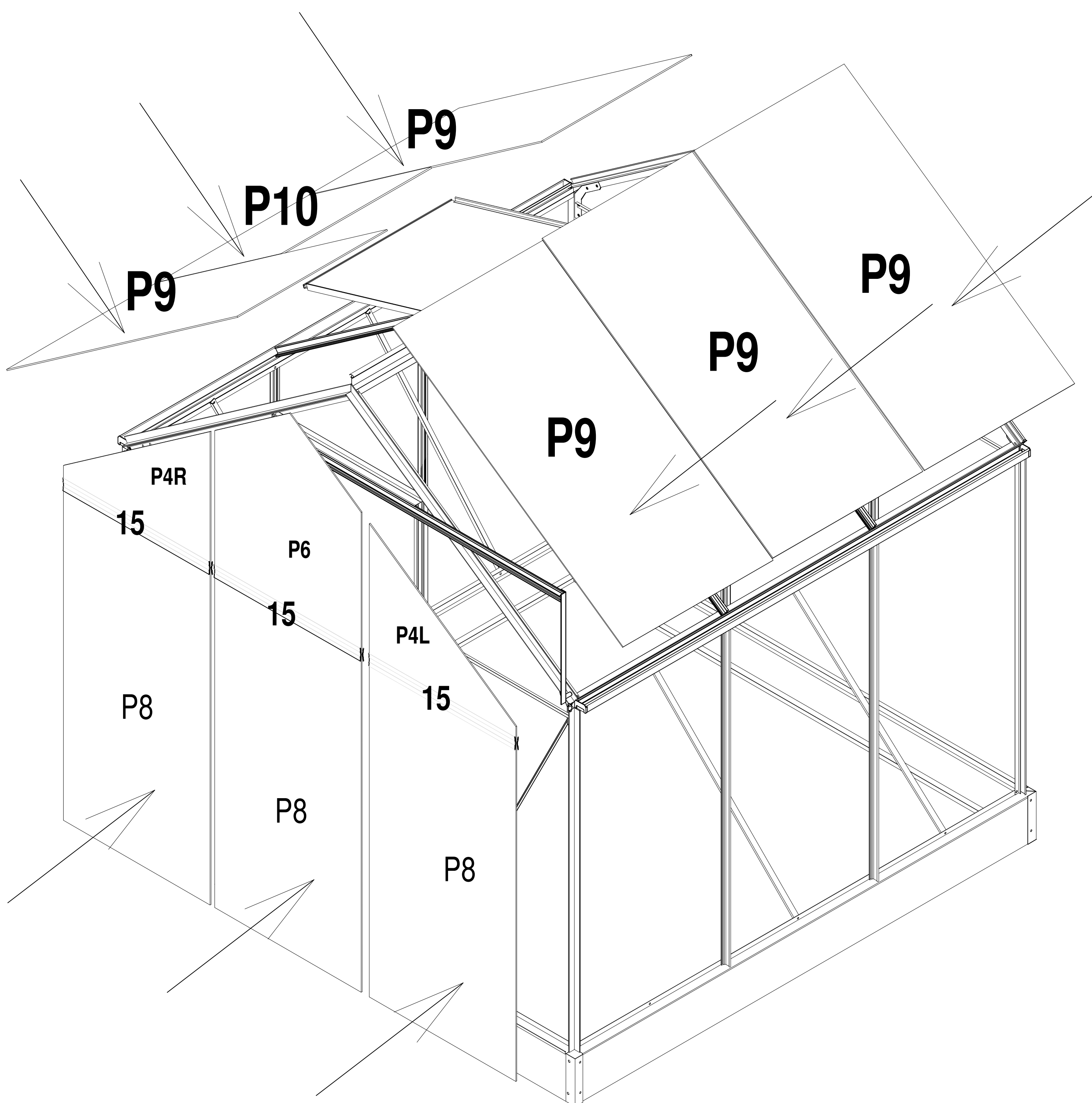
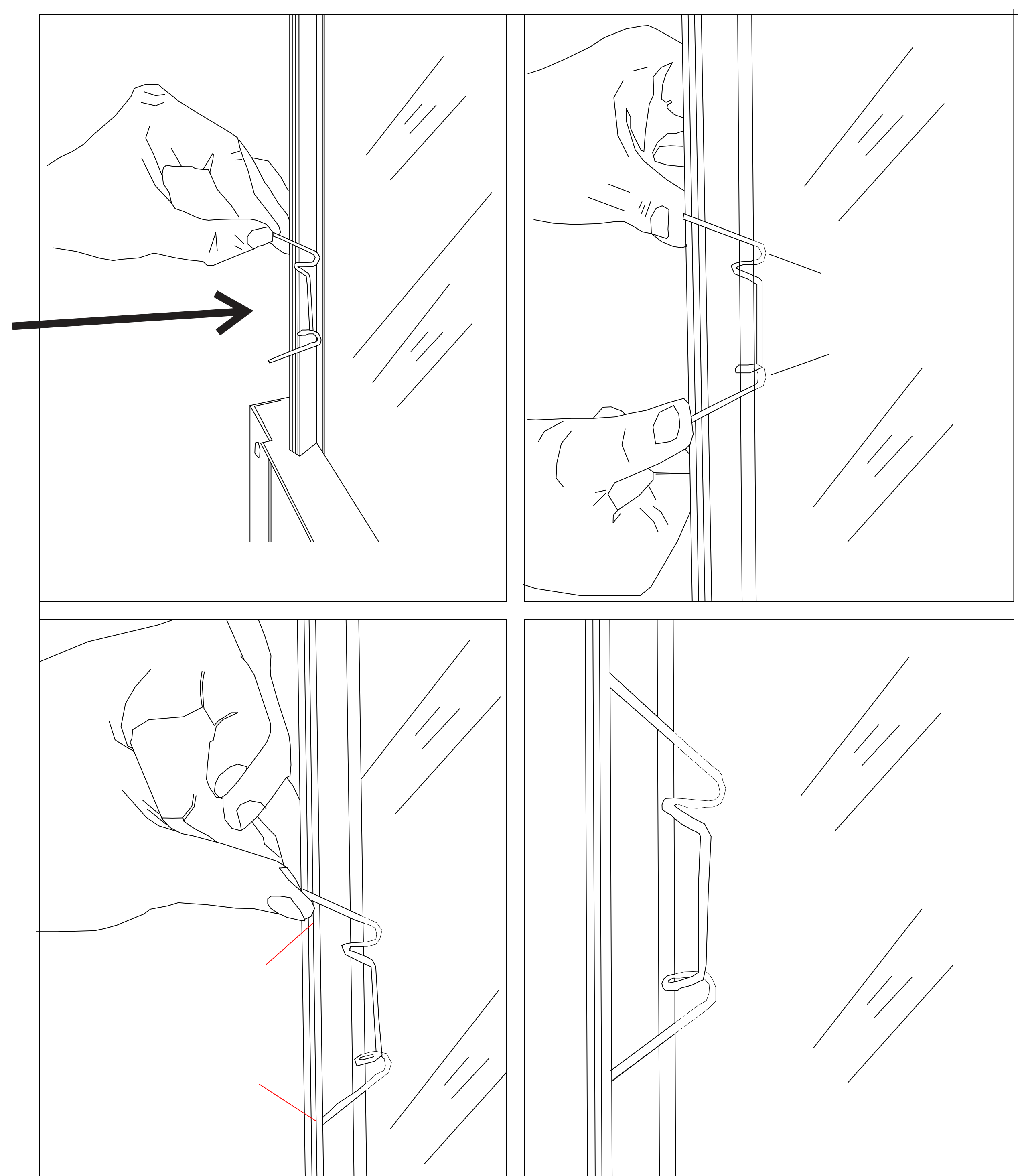

EN Use the "B3" clip to buckle the PC sheet with the profile like this
FR Utilisez le clip "B3" pour attacher la feuille PC au profil comme suit
ES Utilice el clip "B3" para abrochar la hoja de PC con el perfil de esta forma
PT Utilizar o clipe "B3" para prender a folha de PC ao perfil da seguinte forma
DE Verwenden Sie den "B3"-Clip, um die PC-Platte wie folgt mit dem Profil zu verbinden
IT Utilizzare la clip "B3" per fissare il foglio di PC con il profilo, come segue

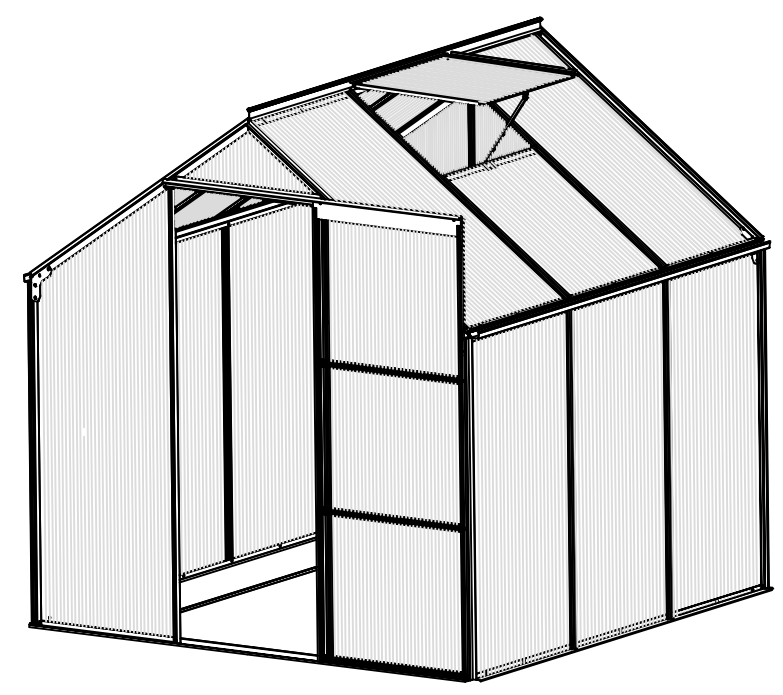

EN Make one end of the clip into the groove and make it support to the profile, then force the other end make the clip tensional, put the other end into the groove.
FR Faire entrer une extrémité du clip dans la rainure et le faire supporter au profil, puis forcer l'autre extrémité pour rendre le clip tendu, mettre l'autre extrémité dans la rainure.
ES Introduzca un extremo del clip en la ranura y haga que se apoye en el perfil, luego fuerce el otro extremo para que el clip se tense, introduzca el otro extremo en la ranura.
PT Introduzir uma extremidade do clip na ranhura e apoiá-la no perfil, depois forçar a outra extremidade para tornar o clip tensional, colocar a outra extremidade na ranhura.
DE Ein Ende des Clips in die Nut einführen und am Profil abstützen, dann das andere Ende mit Kraft spannen, das andere Ende in die Nut einführen.
IT Inserire un'estremità della clip nella scanalatura e farla aderire al profilo, quindi forzare l'altra estremità per rendere la clip tesa, inserire l'altra estremità nella scanalatura.



S10 x100 

S11 x100 

F10 x100 

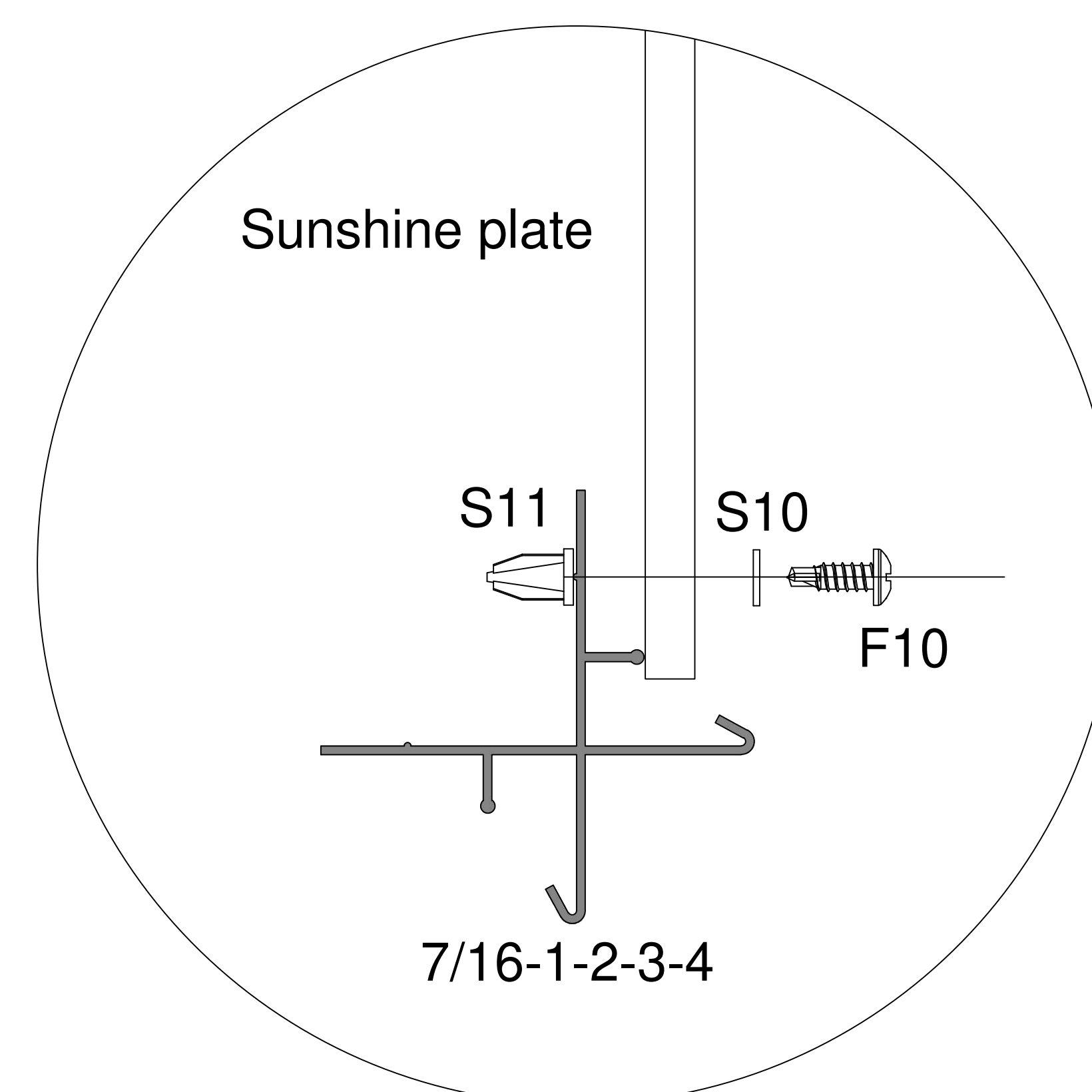
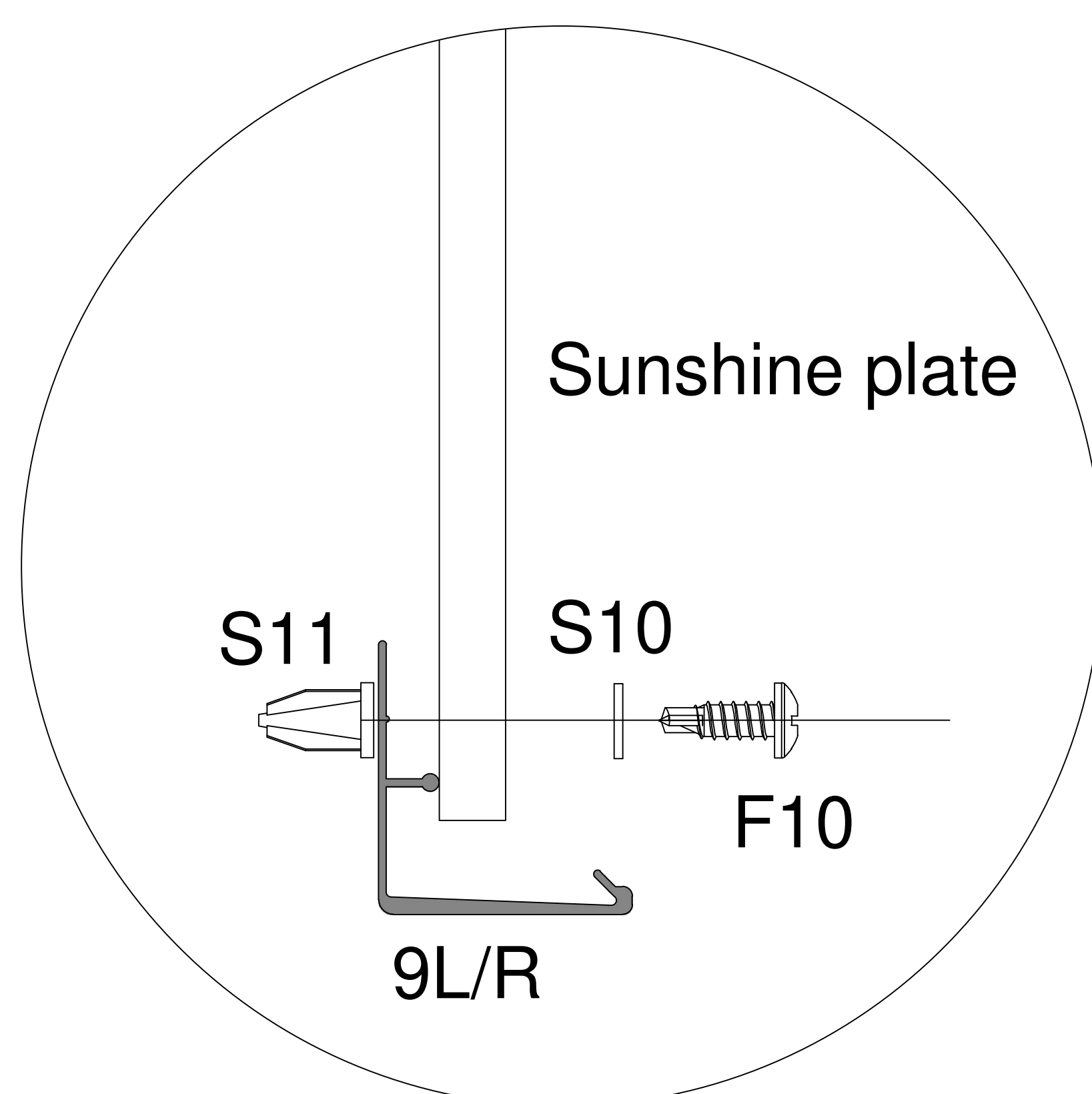
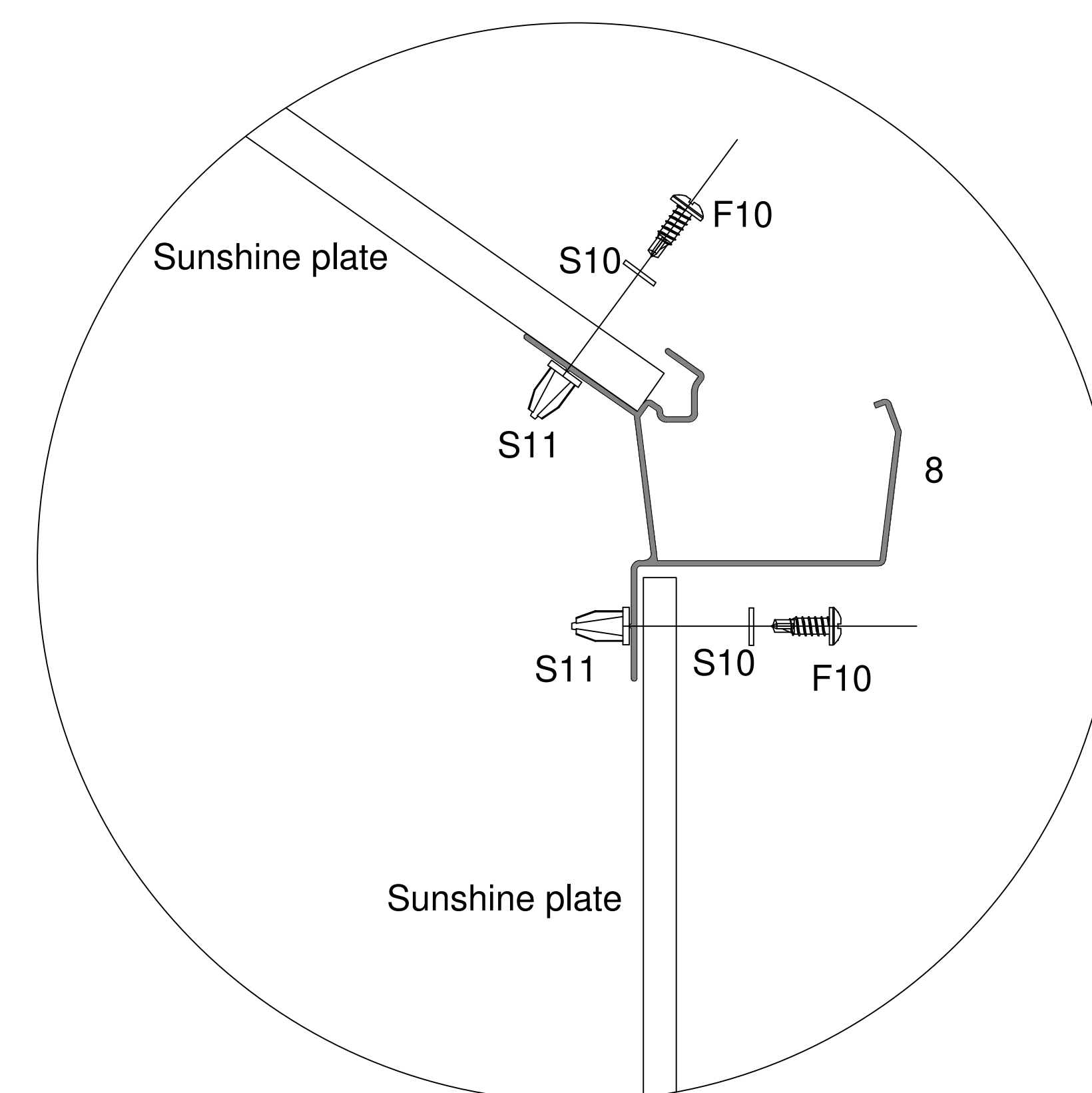
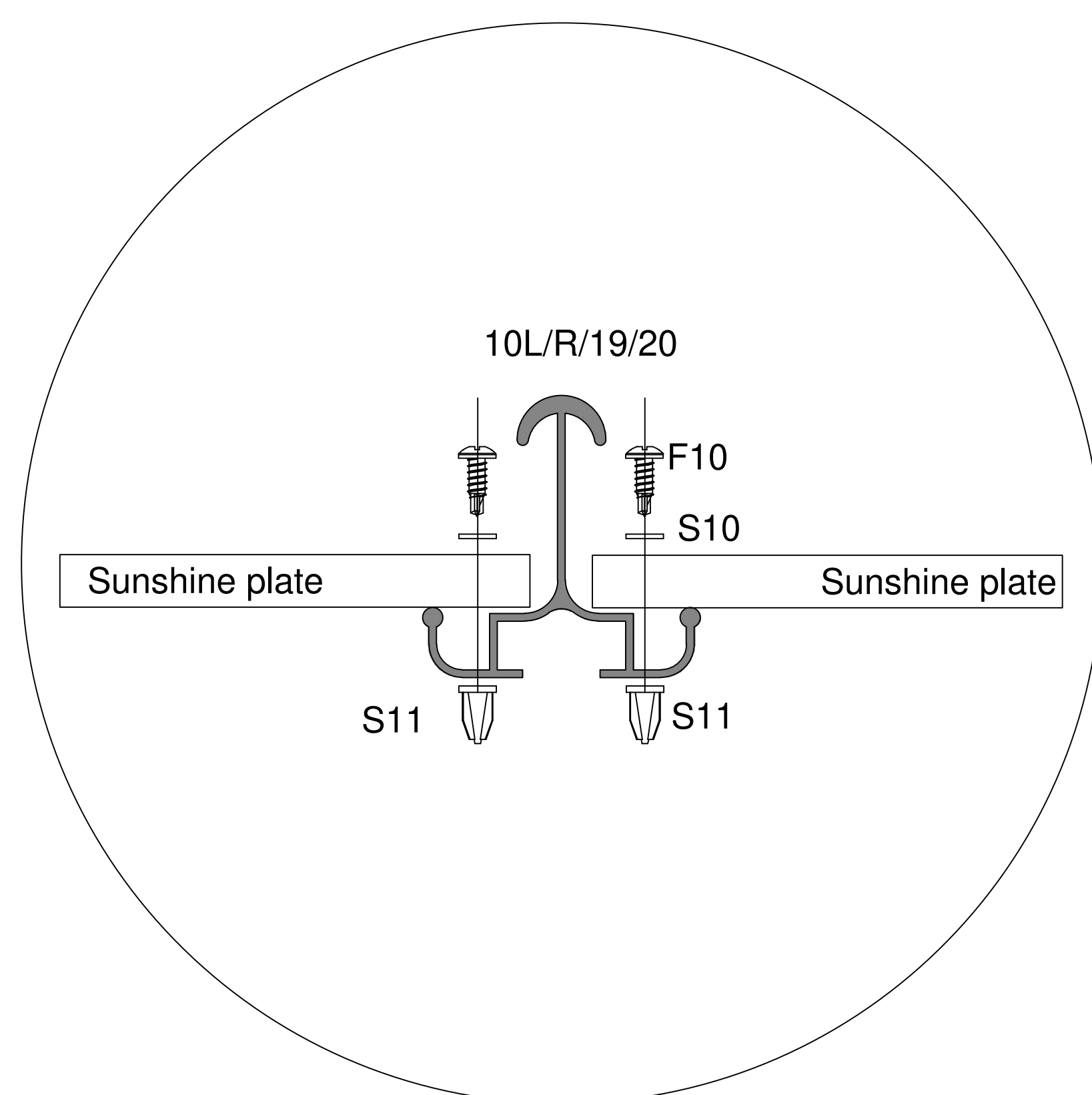
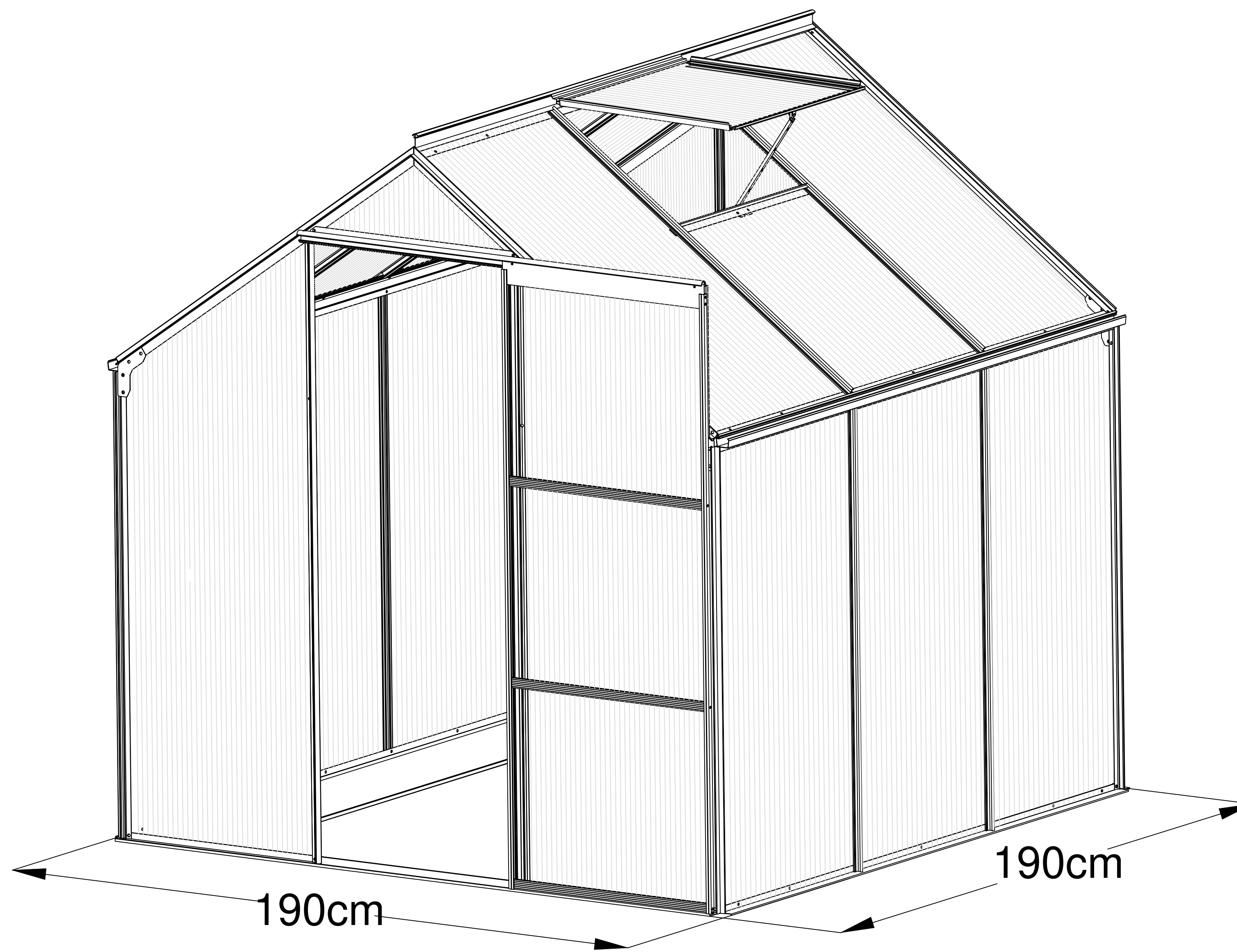

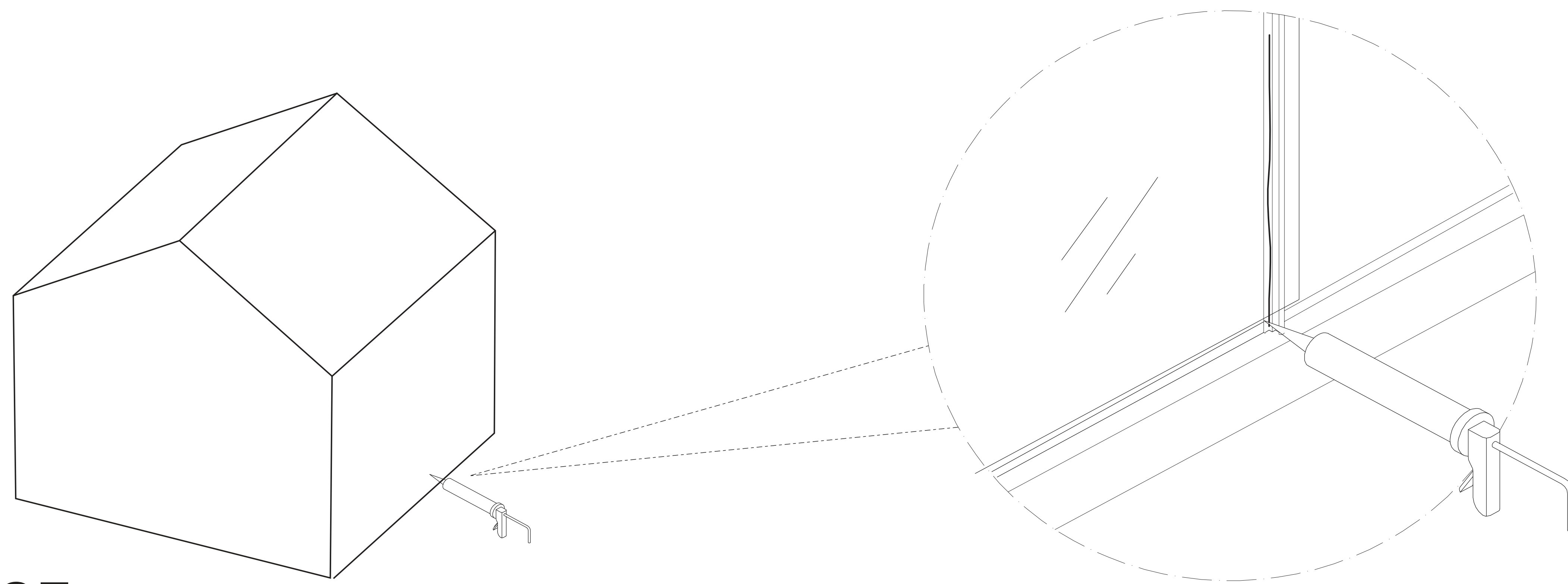

EN_ADVICE

It is not necessary but we would advise: For additional strength, you can also use some glue or tapes between the polycarbonate panel and the aluminium frame to enhance the stability.

Note: Silicone sealant and glue gun are not included in our tool kit. You can buy them locally. Only use silicone sealant suitable for aluminium

FR_CONSEILS

Ce n'est pas nécessaire mais nous vous conseillons:

Pour plus de solidité, vous pouvez également utiliser de la colle ou des rubans adhésifs entre le panneau en polycarbonate et le cadre en aluminium pour améliorer la stabilité.

Not : Le mastic silicone et le pistolet à colle ne sont pas inclus dans notre kit d'outils. Vous pouvez les acheter sur place. N'utilisez que du mastic silicone adapté à l'aluminium

ES_CONSEJO

No es necesario, pero le aconsejamos: Para mayor resistencia, también puede usar pegamento o cintas entre el panel de policarbonato y el marco de aluminio para mejorar la estabilidad.

Nota: El sellador de silicona y la pistola de pegamento no están incluidos en nuestro kit de herramientas. Puede comprarlos localmente. Sólo utilice el sellador de silicona adecuado para aluminio

PT_ATENÇÃO

Não é necessário, mas aconselhamos: Para uma resistência adicional, também se pode utilizar alguma cola ou fita adesiva entre o painel de policarbonato e a estrutura de alumínio para aumentar a estabilidade.

Nota: O selante de silicone e a pistola de cola não estão incluídos no nosso kit de ferramentas. Podem ser comprados localmente. Utilizar apenas selante de silicone adequado para alumínio

DE_RAT

Es ist nicht notwendig, aber wir würden vorschlagen: Um die Festigkeit zu erhöhen, können Sie auch etwas Kleber oder Klebeband zwischen der Polycarbonatplatte und dem Aluminiumrahmen verwenden, um die Stabilität zu verbessern.

Hinweis: Silikondichtmittel und Klebepistole sind nicht in unserem Werkzeugsatz enthalten. Sie können sie vor Ort kaufen. Verwenden Sie nur für Aluminium geeignetes Silikondichtmittel

IT_SUGGERIMENTI

Non è necessario ma consigliamo: Per una maggiore resistenza, puoi anche usare della colla o dei nastri tra il pannello in policarbonato e la struttura in alluminio per migliorare la stabilità.

Nota: il sigillante siliconico e la pistola per colla non sono inclusi nel nostro kit di attrezzi.

Puoi acquistarli localmente. Utilizzare solo sigillante siliconico adatto per alluminio.

US

Imported by Aosom LLC
 27150 SW Kinsman Rd Wilsonville, OR 97070 USA
 MADE IN CHINA

CA

Imported by Aosom Canada Inc.
 7270 Woodbine Avenue, Unit 307, Markham, Ontario Canada
 L3R 4B9
 MADE IN CHINA

Importé par Aosom Canada Inc.
 7270 Woodbine Avenue, unité 307, Markham, Ontario Canada
 L3R 4B9
 Fabriqué en Chine

UK

IMPORTER ADDRESS:
 MH STAR UK LTD
 Unit 27, Perivale Park,
 Horsenden lane South
 Perivale, UB6 7RH
 MADE IN CHINA

FR

ADRESSE D'IMPORTATION:
 MH FRANCE
 2 Rue Maurice Hartmann
 92130 Issy Les Moulineaux
 France
 FABRIQUÉ EN CHINE



Adresses sur quefairedemesdechets.fr

ES

IMPORTADOR:
 SPANISH AOSOM, S.L.
 C/ROC GROS,Nº15.08550, ELS HOSTALET DE BALENYÀ, SPAIN.
 B66295775
 WWW.AOSOM.ES
 ATENCIONCLIENTE@AOSOM.ES
 TEL: 931294512
 HECHO EN CHINA

PT

SPANISH AOSOM, S.L
 C.ROC GROS N.15, 08550. ELS HOSTALET DE BALENYÀ
 TEL: 931294512 (SEG-SEX DAS 7:30H ÀS 16:30H)
 INFO@AOSOM.PT
 WWW.AOSOM.PT

DE

ADRESSE DES IMPORTEURE:
 MH Handel GmbH
 Wendenstraße 309
 D-20537 Hamburg
 Germany
 IN CHINA HERGESTELLT

IT

IMPORTATO DA:
 AOSOM Italy srl
 Centro Direzionale Milanofiori
 Strada 1 Palazzo F1
 20057 Assago (MI)
 P.I.: 08567220960
 FATTO IN CINA