

# PawHut

IN231000326V01\_US\_UK

**D06-094V02\_D06-094V06**

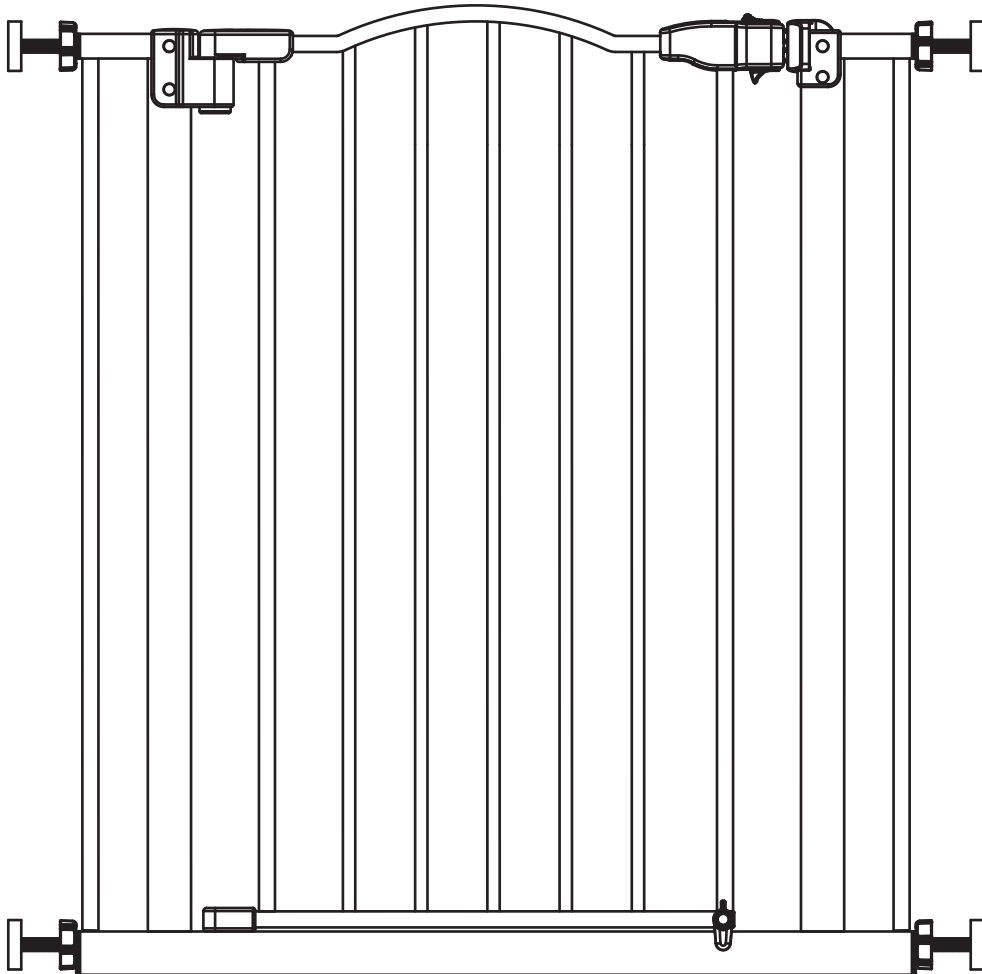

**EN\_IMPORTANT, RETAIN FOR FUTURE REFERENCE: READ CAREFULLY.**

**FR\_IMPORTANT: A LIRE ATTENTIVEMENT ET À CONSERVER POUR CONSULTATION ULTÉRIEURE.**

**ES\_IMPORTANTE, LEA Y GUARDE PARA FUTURAS REFERENCIAS.**

**PT\_IMPORTANTE, RETER PARA REFERÊNCIA FUTURA: LEIA ATENTAMENTE.**

**DE\_WICHTIG! SORGFÄLTIG LESEN UND FÜR SPÄTER NACHSCHLAGEN AUFBEWAHREN.**

**IT\_IMPORTANTE! CONSERVARE IL PRESENTE MANUALE PER FUTURO RIFERIMENTO E LEGGERLO ATTENTAMENTE.**

EN

**Dear customer,**

Thank you for purchasing this product. So that your appliance serves you well, please read all the instructions in this user's manual. If you have any questions, please contact our customer care center, Our contact details are below:

FR

**Cher client,**

Nous vous remercions d'avoir acheté ce produit. Afin que vous puissiez profiter pleinement de votre appareil, veuillez lire toutes les instructions de ce manuel d'utilisation. Si vous avez la moindre question, veuillez contacter notre centre d'assistance à la clientèle, Nos coordonnées sont les suivantes:

DE

**Sehr geehrter Kunde,**

Vielen Dank, dass Sie dieses Produkt erworben haben. Damit Ihr Gerät Ihnen gute Dienste leistet, lesen Sie bitte alle Hinweise in diesem Benutzerhandbuch. Wenn Sie Fragen haben, wenden Sie sich bitte an unser Kundendienstzentrum, Unsere Kontaktdaten stehen unten:

ES

**Queridos clientes,**

Gracias por comprar este producto. Para que su electrodoméstico le sirva mejor, lea todas las instrucciones de este manual del usuario. Si tiene alguna pregunta, comuníquese con nuestro Centro de Atención al Cliente, Nuestros datos de contacto son los siguientes:

PT



**Caros clientes,**

Obrigado por adquirir este produto. Para que o seu aparelho o sirva melhor, leia todas as instruções deste manual do utilizador. Se tiver alguma dúvida, por favor contacte o nosso Centro de Atendimento ao Cliente, Os nossos dados de contacto são os seguintes:

IT

**Caro Cliente,**

Grazie per aver acquistato questo prodotto. Per servirti meglio con questo apparecchio ti prego di leggere tutte le istruzioni in presente manuale utente. In caso di dubbio, si prega di contattare il nostro centro assistenza clienti, I nostri dettagli di contatto sono di seguito:

Country	 Phone	 Email
US	001-877-644-9366	customerservice@aosom.com
CA	416-792-6088	customerservice@aosom.ca
UK	0044-800-240-4004	enquiries@mhstar.co.uk
DE	0049-0(40)-88307530	service@aosom.de
FR	0033-1-84166106	aosom@mhfrance.fr
ES	0034-931294512	atencioncliente@aosom.es
PT	0034-931294512	info@aosom.pt
IT	0039-0249471447	clienti@aosom.it

# BEFORE USING PRODUCT

## IMPORTANT

- Improper installation could result in the gate becoming unstable or dislodged from the doorway.
- Base locks are to be used at all times, on both sides of the gate.
- This product will not necessarily prevent all accidents.
- **Check the gate regularly to see if all the hardware and mountings are tightened.**
- Do not use if any components are missing or damaged.
- STOP using when a pet can climb over or dislodge the gate.
- Additional or replacement parts should only be obtained from the manufacturer or distributor.

## WARNING

**Children have died or been seriously injured when gates are not securely installed.**

- ALWAYS install and use gates as directed using all required parts.
- YOU must install wall cups to keep gate in place. Without wall cups, child can push out and escape.
- STOP using when a child can climb over or dislodge the gate.
- USE only with the locking mechanism securely engaged.
- NEVER use to keep child away from pool.
  
- NEVER leave child unattended.
- Intended for use with children between 6 and 24 months.
- Install according to manufacturer' s instructions.

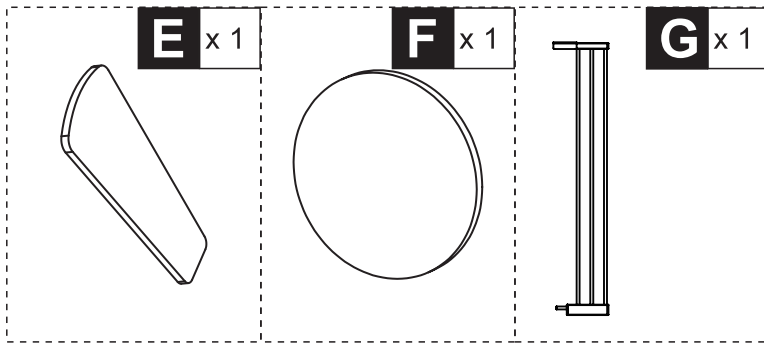
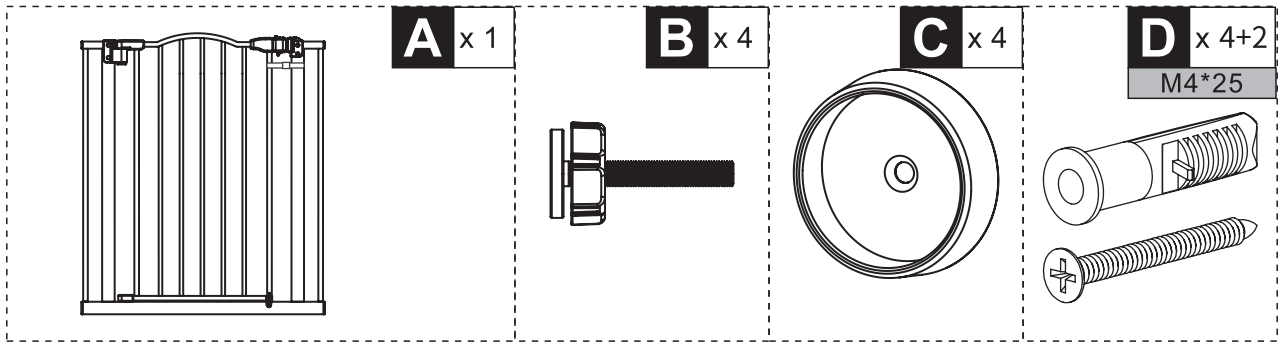

## EXTENSIONS AND MAX SIZE

MODEL NO.	No Extension	7cm(2.75in) Extension	14cm(5.51in) Extension	MAX SIZE
D06-094V02	✓		✓	29 - 36.5inch
D06-094V06	✓		✓	29 - 36.5inch

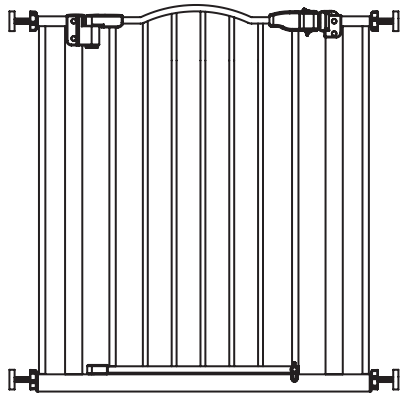

No Extension  
74 - 79cm  
29 - 31 inch



With **14cm(5.51in)**  
88 - 93cm  
34.5 - 36.5 inch

# INSTALLING YOUR GATE

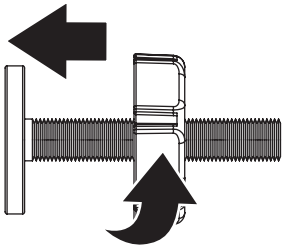
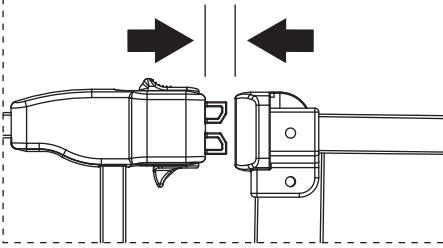

Figure 1-1

Locate the (4) threaded spindle rods (B). Rotate the adjustment wheels along the threading, eliminating the gap between the adjustment wheel and the rubber foot (Figure 1-1).

Figure 1-2



NOTE You may notice a slight gap between the gate door latch and the frame (Figure 1-2).

**THIS IS NOT A DEFECT** this gate is a pressure mounted gate and this gap will disappear once you tighten the gate in its opening.

Figure 1-3

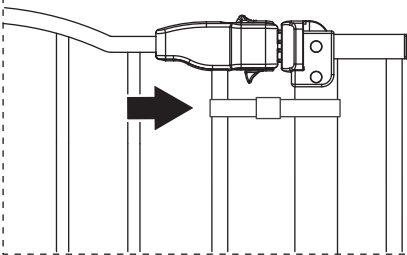

**DO NOT REMOVE THE ZIP TIE UNTIL INSTALLATION IS COMPLETE.**

(Figure 1-3)

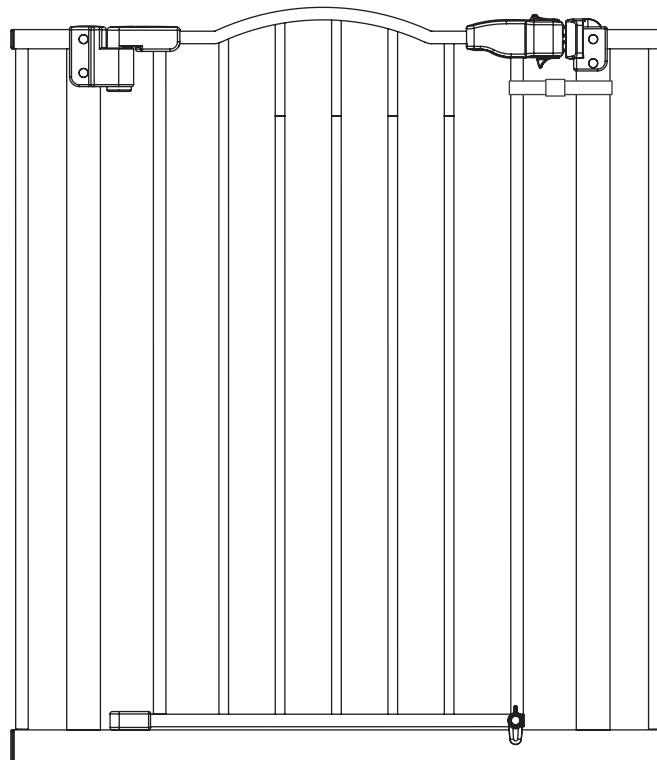
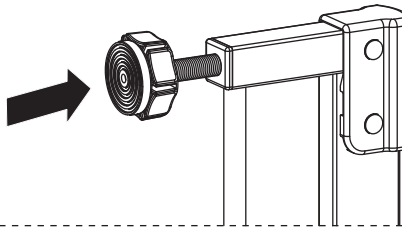
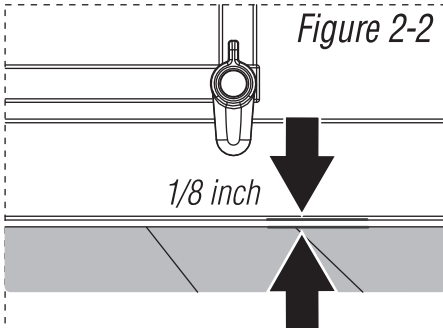

Figure 2-1



Insert the threaded spindle rods with adjustment wheels into the hole on all four corners of the sides of the gate. (Figure 2-1)

Figure 2-2



Place the gate in desired opening with the bottom close to the floor. The distance between the bottom of the gate and the floor should be less than 1/8 inch (Figure 2-2).

Figure 2-3

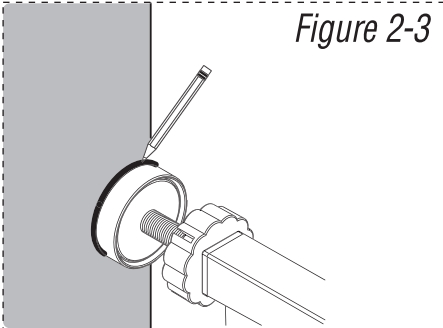

Once you are satisfied with the placement of your gate trace the spindle rods rubber feet onto the surface of your opening making sure these are level (Figure 2-3). Then remove the gate from the opening. Then screw the 4 wall cups to the wall using the screws (Figure 2-4), or paste the 4 wall cups using the stickers provided (Figure 2-5).

Figure 2-4

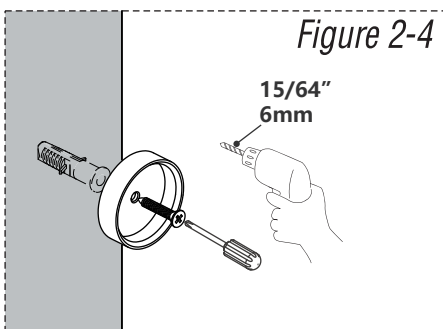

Figure 2-5

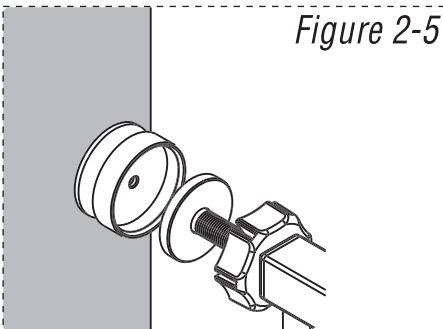

Figure 3-1

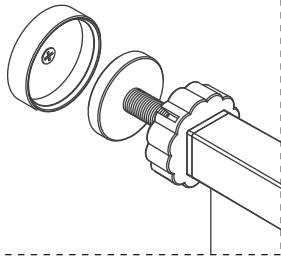

Figure 3-2

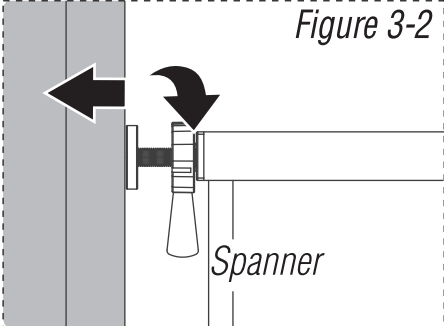

Figure 3-3

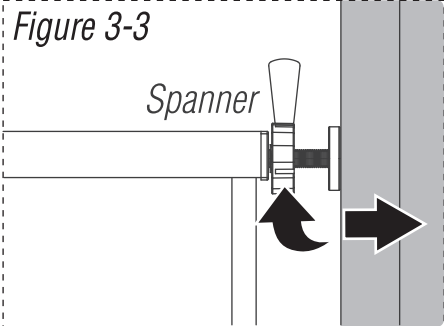

Figure 3-4

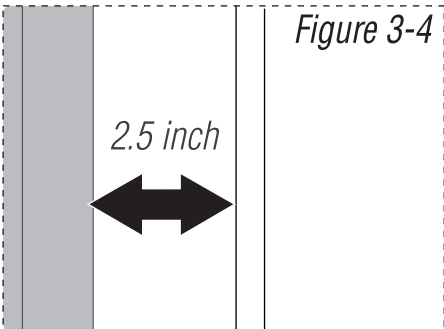

Figure 3-5

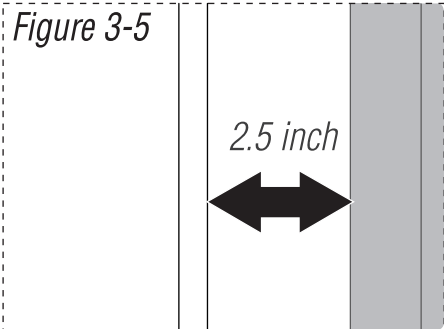
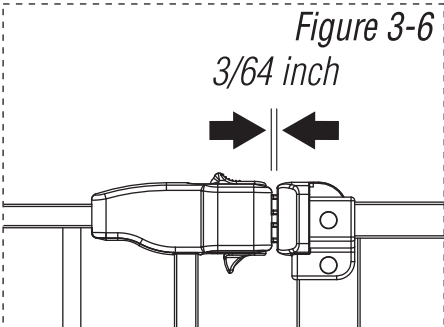

Figure 3-6



Insert all 4 threaded spindle rods into the wall cups (Figure 3-1). Tighten the wheels using the spanner tool. (Figure 3-2 and Figure 3-3) Do not over tighten. It may be necessary to hold the threaded spindle rods while rotating the adjustment wheels to ensure that the entire unit does not rotate while installing the gate.

**NOTE** if your door latch is not properly engaging with the receiving component, ensure that your gate is level, mounted properly and that you have not over-tightened the adjustment wheels.

**NOTE** The gap between the gate and the wall should not exceed more than **2.5 inch** on either side (Figure 3-4 and 3-5)

**If the gate has been installed properly the gap between the door latch and frame should now be closed** (Figure 3-6)

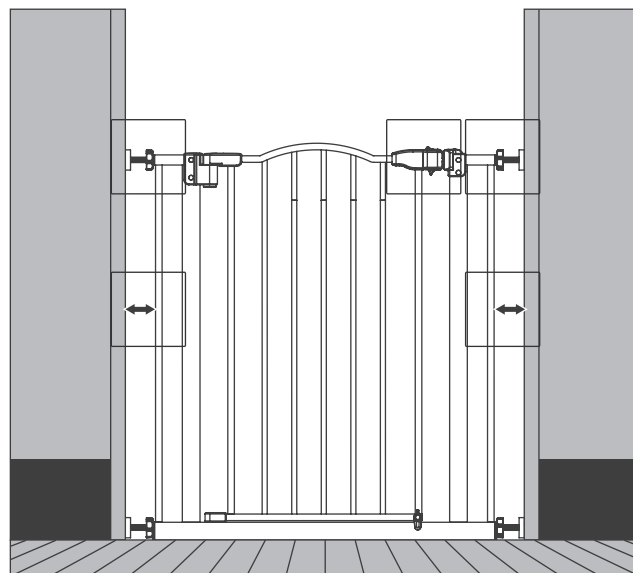

# OPERATING THE DOOR LATCH

Figure 4-1

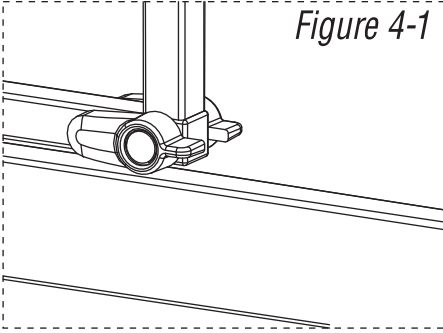

**To Open** - Ensure that the base locks at the bottom of the gate door are in the horizontal position, (Figure 4-1) then slide the top and bottom levers toward the door and swing open. (Figure 4-2)

Figure 4-2

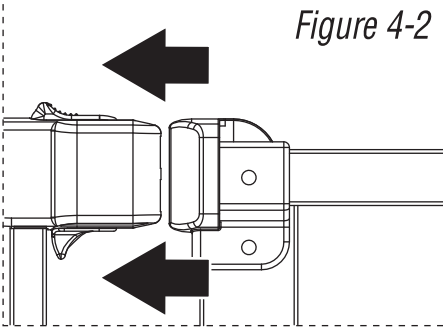

**To Close** - Pull the door shut and ensure that the door latch on top closes and then place the lock at the bottom of the gate door down on the side occupied by the child, Gate will swing both ways unless one of the swing stops is down. Gate will not swing at all if both swing stops are down.(Figure 4-3)

Figure 4-3

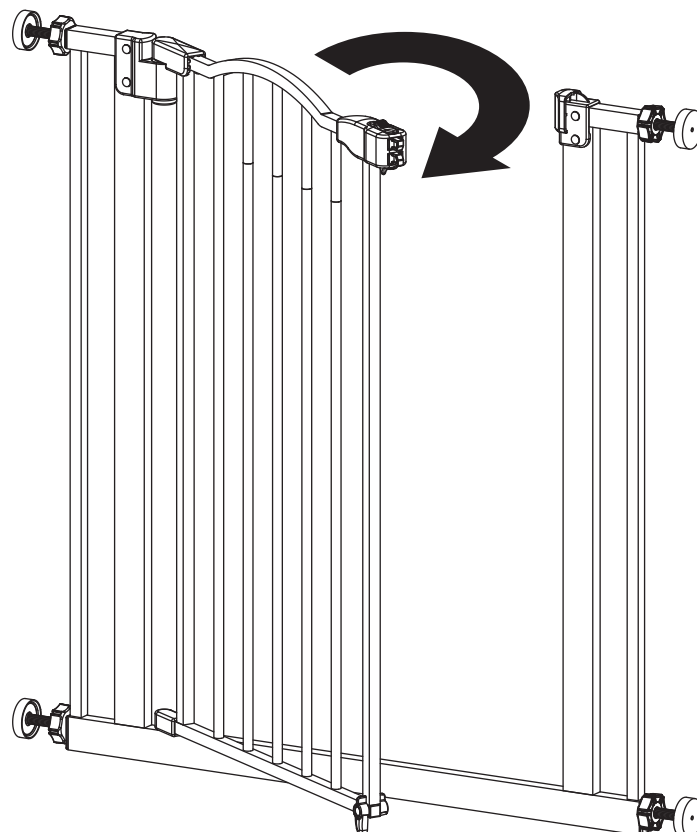
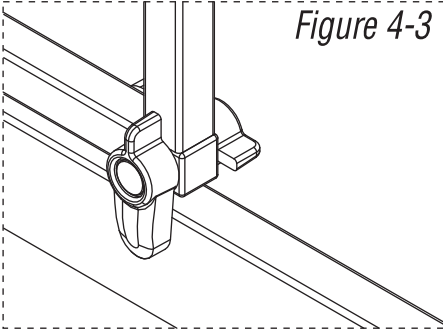



# AUTO CLOSE LOCK

Figure 5-1

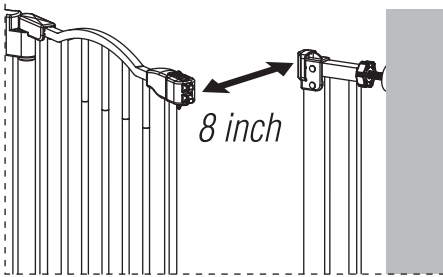

Once the gate is opened, it can close up automatically and lock up.

When the opening width of the gate is **8 inch**, the gate has the function of Automatic Closing (Figure 5-1).

Figure 5-2

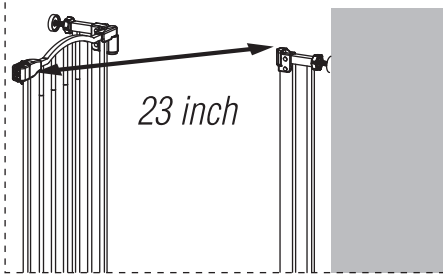

NOTE When the gate opening width is greater than **23 inch**, the gate will be normally open. (Figure 5-2)

# USE AT THE TOP OF STAIRS

Figure A

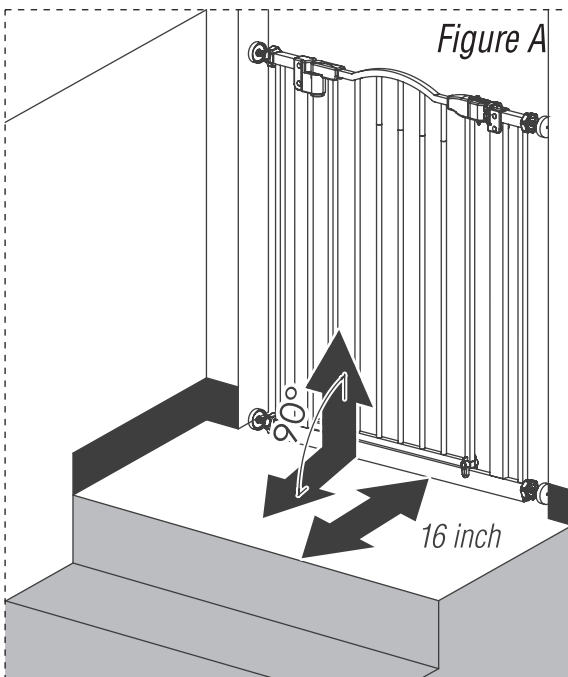

If the gate is used at the top of stairs, we recommend the safe distance to the 1st step is at least 16 inch. (Figure A)

**Using the wall cups will affix your gate more firmly in the doorway or opening.**

# ADDING A GATE EXTENSION

Figure 6-1

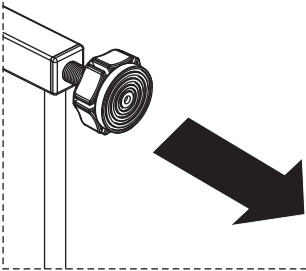

Remove the top and bottom threaded spindle rods.(Figure 6-1)

Figure 6-2

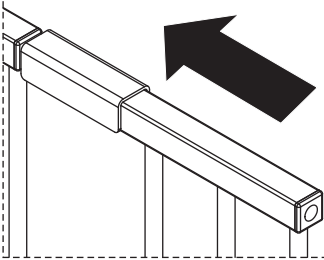

Assemble the gate and extension as illustrated (Figure 6-2 and 6-3). Reposition the gate and fit in accordance with the gate fitting instructions.

Figure 6-3

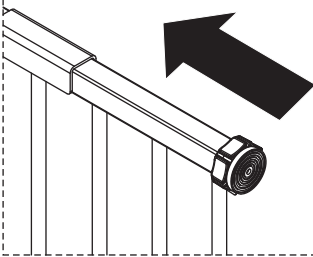

**NOTE:** It is preferable to install any extensions on the hinge side of the gate.

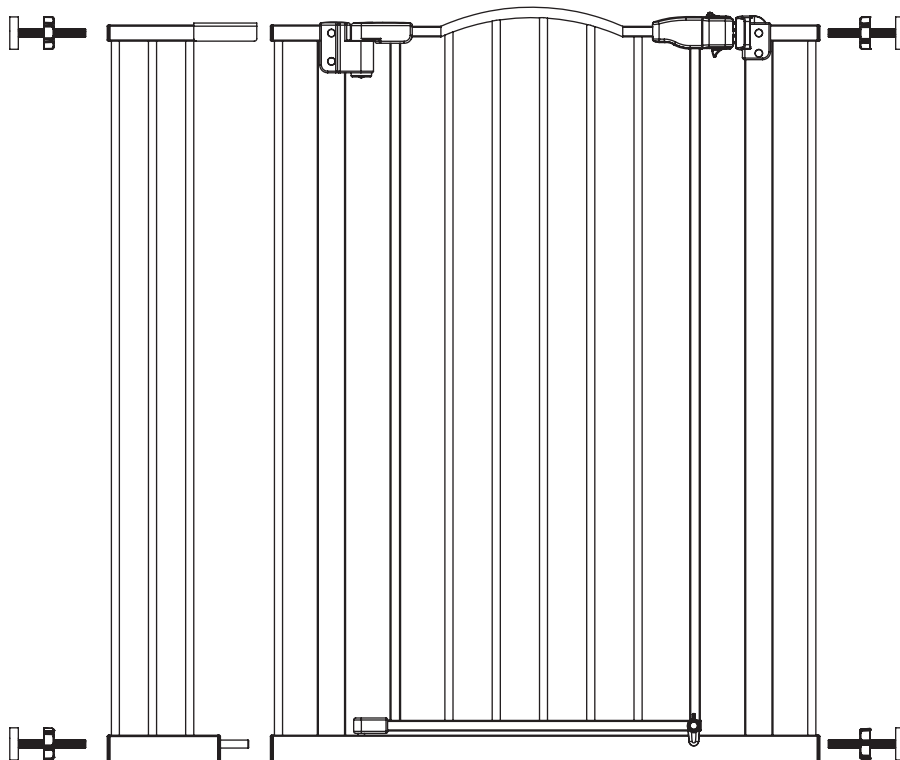

## REMOVING YOUR GATE FROM THE WALL

To remove your gate from the wall, rotate the adjustment wheels on each of the (4) threaded spindle rods to depressurize the gate from its doorway or opening. Then, gently pull or push the gate free from its doorway or opening.

## CARE AND MAINTENANCE

Periodically check the gate for signs of damage, wear, or missing components.

Do not use if any part is missing, worn or damaged.

Check the gate regularly to ensure all the hardware and mountings are tightened. Do not use abrasive cleaners or bleach. Clean by sponging with warm water and a mild detergent.

**US**

Imported by Aosom LLC  
27150 SW Kinsman Rd Wilsonville, OR 97070 USA  
MADE IN CHINA

**CA**

Imported by Aosom Canada Inc.  
7270 Woodbine Avenue, Unit 307, Markham, Ontario Canada  
L3R 4B9  
MADE IN CHINA

Importé par Aosom Canada Inc.  
7270 Woodbine Avenue, unité 307, Markham, Ontario Canada  
L3R 4B9  
Fabriqué en Chine

**UK**

IMPORTER ADDRESS:  
MH STAR UK LTD  
Unit 27, Perivale Park,  
Horsenden lane South  
Perivale, UB6 7RH  
MADE IN CHINA

**FR**

ADRESSE D'IMPORTATION:  
MH FRANCE  
2 Rue Maurice Hartmann  
92130 Issy Les Moulineaux  
France  
FABRIQUÉ EN CHINE



Adresses sur [quefairedemesdechets.fr](http://quefairedemesdechets.fr)

**ES**

IMPORTADOR:  
SPANISH AOSOM, S.L.  
C/ROC GROS, Nº15.08550, ELS HOSTALET DE BALENYÀ, SPAIN.  
B66295775  
WWW.AOSOM.ES  
ATENCIONCLIENTE@AOSOM.ES  
TEL: 931294512  
HECHO EN CHINA

**PT**

SPANISH AOSOM, S.L  
C.ROC GROS N.15, 08550. ELS HOSTALET DE BALENYÀ  
TEL: 931294512 (SEG-SEX DAS 7:30H ÀS 16:30H)  
INFO@AOSOM.PT  
WWW.AOSOM.PT

**DE**

ADRESSE DES IMPORTEURS:  
MH Handel GmbH  
Wendenstraße 309  
D-20537 Hamburg  
Germany  
IN CHINA HERGESTELLT

**IT**

IMPORTATO DA:  
AOSOM Italy srl  
Centro Direzionale Milanofiori  
Strada 1 Palazzo F1  
20057 Assago (MI)  
P.I.: 08567220960  
FATTO IN CINA