

SPORTNOW

IN231000375V01_UK

A61-052V00

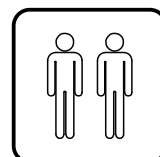
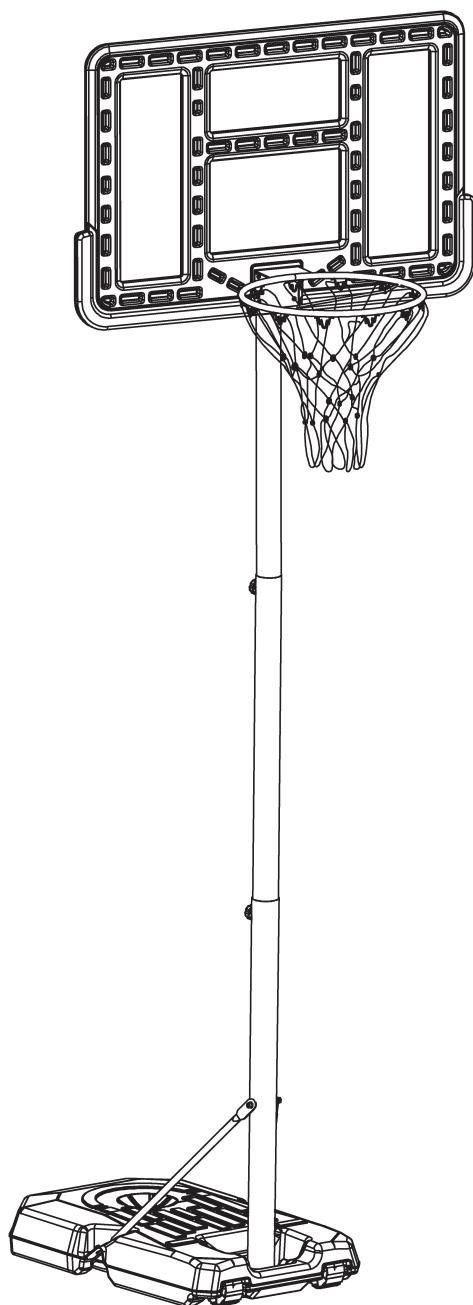

IMPORTANT, RETAIN FOR FUTURE REFERENCE: READ CAREFULLY

ASSEMBLY INSTRUCTIONS

SAFETY INSTRUCTIONS

FAILURE TO FOLLOW THESE WARNINGS MAY RESULT IN SERIOUS INJURY OR PROPERTY DAMAGE.

To ensure safety, do not attempt to assemble this product without reading and following all instructions carefully. Check the entire box and inside all packing materials for parts and/or additional instruction material. Before beginning assembly, identify and inventory all parts and hardware using the parts and hardware lists and identifiers in this document.

Proper and complete assembly, use and supervision are essential for proper orientation and to reduce the risk of accident or injury. A high probability of serious injury exists if this product is not installed, maintained, and/or operated properly.

Failure to comply with any of the warnings in this instruction manual may result in serious personal injuries such as cuts, broken bones, nerve damage, paralysis, brain injury, or death. Failure to comply may also result in property damage. Please heed all warnings and cautions.

- If using a ladder during assembly, use extreme caution.
- Only adults should set up the product. Do not allow children in the setup area until assembly is complete.
- Check base daily for leakage. Leaks may cause product to fall.
- Assemble the pole sections properly. Failure to do so could cause the pole sections to separate during play or transport.
- **Most injuries are caused by misuse and/or not following instructions. Use caution when using this product.**



WARNING

For safety reasons, we recommend that sand be used instead of water to fill the Base. If a leak develops, water could run out unnoticed, allowing the system to fall over, resulting in serious personal injuries, or property damage.

If using Water, check the Base carefully for leaks. If a leak is found, lay the system down on the ground and call Customer Service. Do not use, stand up, or play on a leaking system.





WARNING

OWNERS MUST ENSURE THAT ALL PLAYERS KNOW AND FOLLOW THESE RULES FOR SAFE OPERATION OF THE SYSTEM.

1. Do Not allow children to move or adjust the system.
2. Always make sure adjustment knob is securely tightened before play.
3. Make sure cement anchors are installed properly during assembly and that they are secure before play.
4. During play, especially when performing dunk type activities, keep players face away from the backboard, rim and net. Serious injury could occur if teeth/face come in contact with the backboard, rim or net. Player should wear mouth guard during play.
5. Only hang from rim briefly to regain balance or avoid injuring others. Release the rim as soon as safely possible.
6. DO NOT slide, climb or play on base or pole.
7. Before each use, always check that the base is filled according to manufacturer's instructions. Check for loose hardware, instability, and signs of corrosion and repair before each use. Check the base for leaks. If a leak exists, water could run out unnoticed, allowing the unit to fall over. Never play on damaged equipment.
8. Surface beneath the base must be smooth and free of gravel or other objects. Punctures can cause leakage and could cause system to tip over.
9. During play, do not wear Jewelry (rings, watches, necklaces, etc.). Objects may entangle in net.
10. When moving system, keep hands and fingers away from moving parts.
11. Once a month check pole and all metal parts for rust. Completely remove rust and repaint with exterior enamel. If rust has penetrated any steel part, replace that part before using system again. Keep water and organic material away from pole.
12. Never operate or leave the unit standing in an upright position without first filling the base with weight and securing cement anchors or it may tip over into the pool and cause injuries such as those listed above.
13. Do not use system during windy or severe weather. System may tip over. Place system in an area protected from the wind or in an area away from property that may be damaged if the system falls.

TRANSPORTING THE PORTABLE BASE



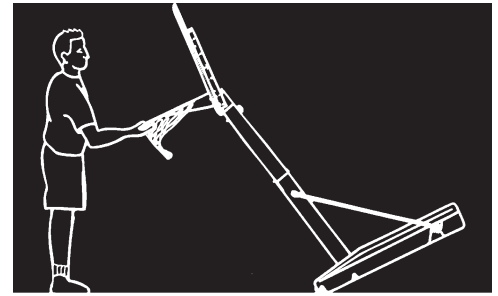



1. Make sure the base is empty before moving.
2. Face the front of the base where the wheels are located and pull back on the pole until the unit is balanced on its wheels.
3. Move the unit to the desired location and carefully set it down.
4. Fill the Base, secure cement anchors and check portable base for stability before play.











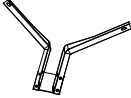
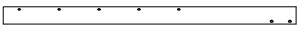

ADJUSTING THE SYSTEM

1. One person must stabilize the backboard, while the other person removes the pole locking knob and bolt.
2. Adjust the pole to desired height, and replace the knob and bolt.
3. Make sure adjustment knob is secure.

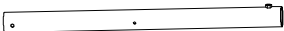
HARDWARE

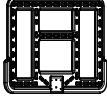
Number	Name	Parts	Qty
A	Bolt,Washer sets M8*25		2
B	Bolt,Washer sets M8*90		1
C	Bolt,Washer sets M10*80		2
D	Screw		2
E	Bolt,Washer sets M8*40		4
F	Bolt, Washer M10*16		2
G	Tools		4

COMPONENTS

Number	Name	Parts	Qty
1A	Axle		2
1B	Axle		1
2	Lower Brace		2
3	Backboard Frame		1
4	Top Pole		1
5	Middle Pole		1
6	Lower Pole		1
7	Goal Ring		1
8	Backboard		1
9	Net		1
10	Wheel		2
11	Base		1

STEP 1

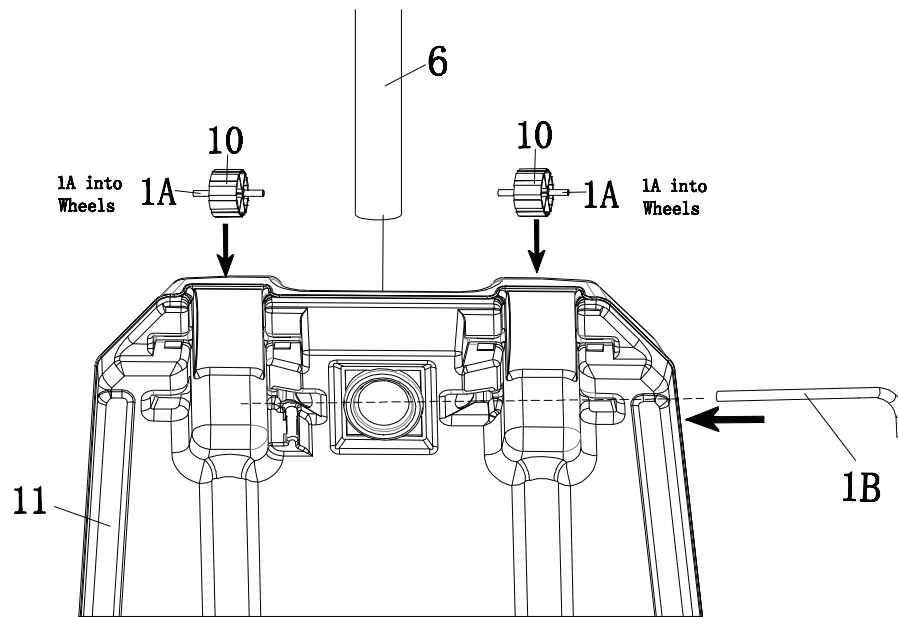

To build the first part of this assembly you will need: Lower Pole (6) Wheels (10) Base (11) Axle (1A&1B)
Insert the Axles (1A) into the Wheels (10). Align one of the Wheels (10) into the slots on the Base (11), using the help of another person take the Lower Pole (6) and place into the front of the Base (11), Thread the Axle (1B) through the holes, to the Wheel and through the Bottom Pole and through to the second Wheel.

STEP 2

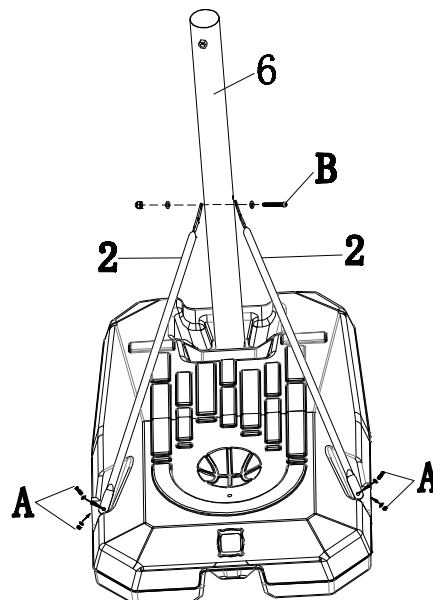

Take both Lower Braces (2) and align the holes up with those on the base, secure the four holes on the base using (A) Bolts.
Then secure to the Lower Pole (6) using (B) BOLTS, tightening to secure.

STEP3

Take the Middle Pole (5) and slot over the Lower Pole (6), ensuring the screw holes are aligned. Secure into place using the Bolts (D), tighten to secure.

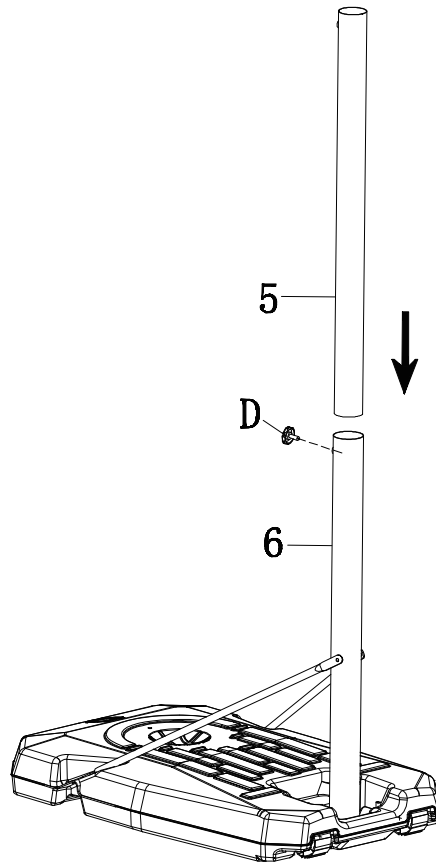

STEP4

Take the Backboard Frame (3) and the Goal Ring (7), align them with the holes on the Backboard (8) and fix with Bolts (E)

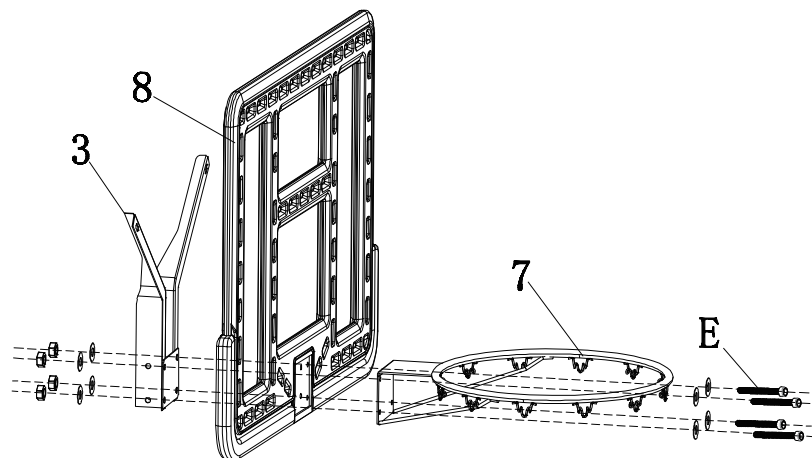

STEP5

Secure the Backboard Frame (3) to the Backboard with Bolts (F). Then fix the Top Pole (4) to the backboard with Bolts (C)

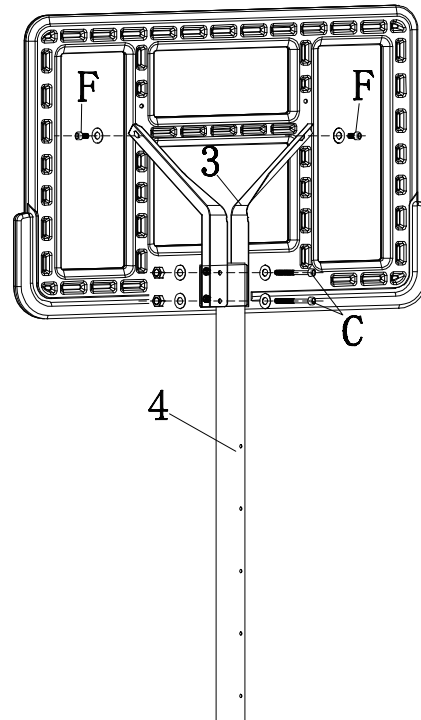

STEP6

Attach Net (9) to the Goal Ring (7) as shown in Fig A.

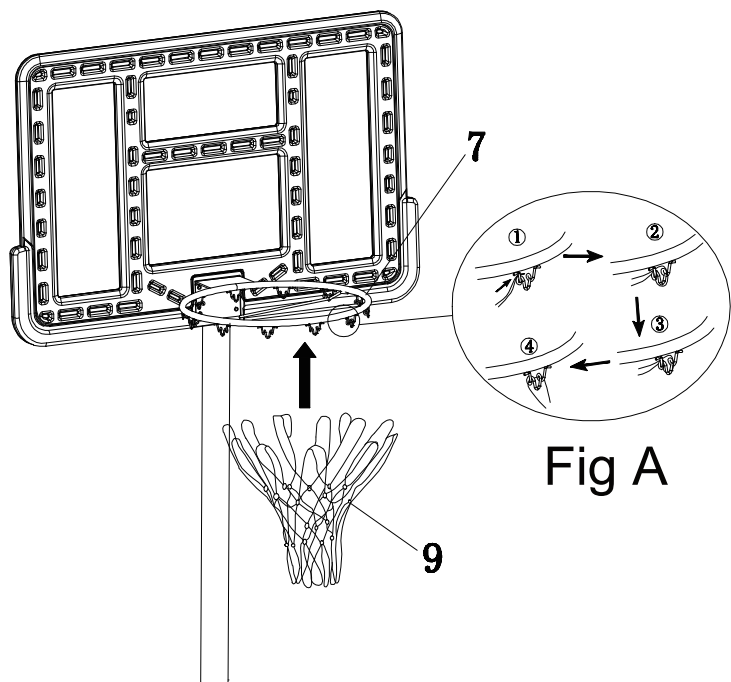

STEP7

This step suggest to use two persons assemble together. With a person holding the bottom part, and another person take the assembled backboard.

Align the Top Pole (4) into the Middle Pole (5) and secure with Bolts D.

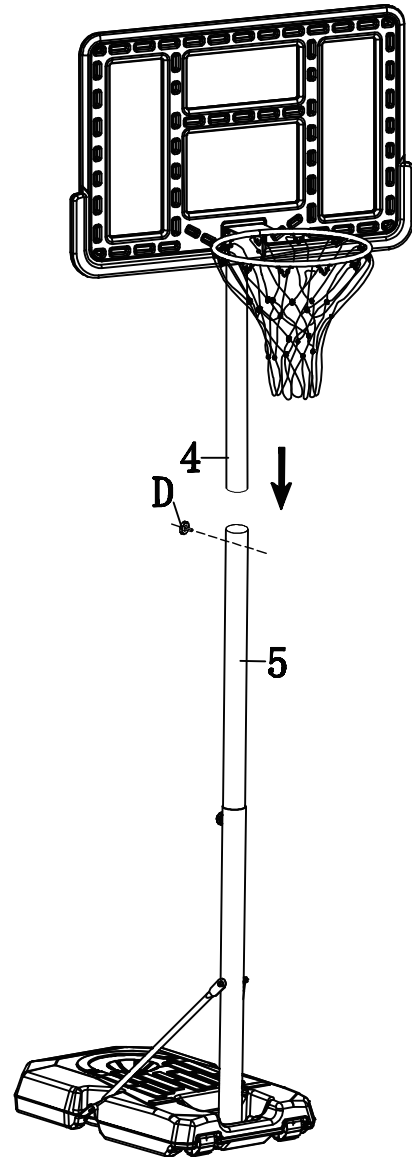

STEP8

With a person holding the basketball stand, fill the Base (11) with water or sand.

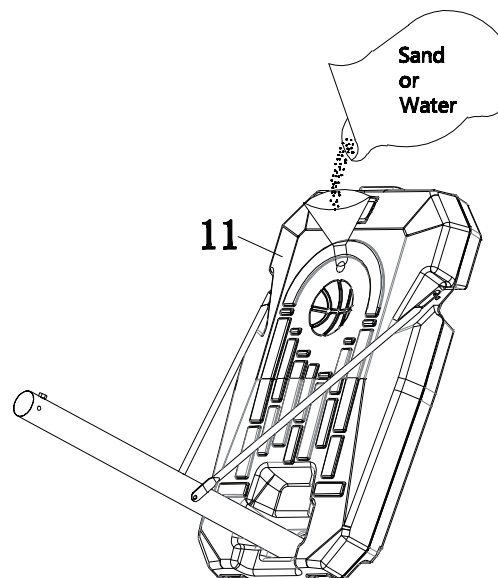

UK

If you have any questions, please contact our customer care center.

Our contact details are below:



0044-800-240-4004



enquiries@mhstar.co.uk

IMPORTER ADDRESS:

MH STAR UK LTD
Unit 27, Perivale Park,
Horsenden lane South
Perivale, UB6 7RH
MADE IN CHINA

ES

Si tiene alguna pregunta, comuníquese con nuestro Centro de Atención al Cliente. Nuestros datos de contacto son los siguientes:



0034-931294512



atencioncliente@aosom.es

IMPORTADOR:

SPANISH AOSOM, S.L.
C/ ROC GROS, N° 15. 08550, ELS HOSTALETS DE
BALENYÀ, SPAIN.
B66295775
WWW.AOSOM.ES
ATENCIONCLIENTE@AOSOM.ES
TEL: 931294512
HECHO EN CHINA

FR

Si vous avez la moindre question, veuillez contacter notre centre d'assistance à la clientèle.

Nos coordonnées sont les suivantes:



0033-1-84166106



aosom@mhfrance.fr

Importé par:

MH France
2, rue Maurice Hartmann
92130 Issy-les-Moulineaux
France
Fabriqué en Chine

PT

Se tiver alguma dúvida, por favor contacte o nosso Centro de Atendimento ao Cliente. Os nossos dados de contacto são os seguintes:



0034-931294512



info@aosom.pt.

IMPORTADOR:

SPANISH AOSOM, S.L
C.ROC GROS N.15, 08550. ELS HOSTALETS DE BALENYÀ
TEL: 931294512 (SEG-SEX DAS 7:30H ÀS 16:30H)
INFO@AOSOM.PT
WWW.AOSOM.PT

DE

Wenn Sie Fragen haben, wenden Sie sich bitte an unser Kundendienstzentrum.

Unsere Kontaktdaten stehen unten:



0049-0(40)-88307530



service@aosom.de

ADRESSE DES IMPORTEUR:

MH Handel GmbH
Wendenstraße 309
D-20537 Hamburg
Germany
IN CHINA HERGESTELLT

IT

In caso di dubbio, si prega di contattare il nostro centro assistenza clienti. I nostri dettagli di contatto sono di seguito:



0039-0249471447



clienti@aosom.it

IMPORTATO DA:

AOSOM Italy srl
Centro Direzionale Milanofiori
Strada 1 Palazzo F1
20057 Assago (MI)
P.I.: 08567220960
FATTO IN CINA