**Assembly instructions**

- Please check if there are any omissions in the instructions
- Please pay attention to the precautions when assembling

**Instructions de montage**

- Veuillez vérifier s'il y a des omissions dans les instructions.
- Veuillez faire attention aux précautions lors du montage.

**Istruzioni di montaggio**

- Si prega di controllare se ci sono le parti mancanti nell'imballaggio.
- Prestare attenzione alle precauzioni durante l'assemblaggio

**EN\_IMPORTANT, RETAIN FOR FUTURE REFERENCE: READ CAREFULLY.**

**FR\_IMPORTANT: A LIRE ATTENTIVEMENT ET À CONSERVER POUR CONSULTATION ULTÉRIEURE.**

**IT\_IMPORTANTE! CONSERVARE IL PRESENTE MANUALE PER FUTURO RIFERIMENTO E LEGGERLO ATTENTAMENTE.**

## EN

---

1. Misuse and abuse of this product can cause serious injury.
2. Read the instructions before using the product.
3. Inspect before use and replace worn, defective or missing parts.
4. Only allowed for adults to install and be used by adults'supervision.
5. Place it on a flat surface,check all the parts are well connected before use.
6. Product for Age: 3+ years old.
7. Only for domestic use.
8. Maximum total weight 50KG

This equipment is to be used only by properly trained, qualified persons under supervised conditions. Use without proper supervision is dangerous and should never be undertaken nor permitted. Manufacturer shall not be liable or responsible for personal injury or property damages incurred through use of this equipment

## FR

---

1. L'utilisation incorrecte et abusive de ce produit peut occasionner des blessures graves.
2. Lisez les instructions avant d'utiliser le produit.
3. Inspectez avant l'utilisation et remplacez les pièces usées, défectueuses ou manquantes.
4. Installation exclusivement réservée aux adultes et utilisation sous la surveillance d'adultes.
5. Placez-le sur une surface plane, vérifiez que toutes les pièces sont bien connectées avant de l'utiliser.
6. Recommandé pour les enfants de 3+ ans.
7. À usage domestique uniquement.
8. Poids total maximum 50KG

Cet équipement ne doit être utilisé que par des personnes qualifiées et correctement entraînées, dans des conditions de surveillance. Le fabricant ne peut être tenu responsable des dommages corporels ou matériels causés par l'utilisation de cet équipement.

## IT

---

1. L'uso improprio e l'abuso di questo prodotto possono causare lesioni personali gravi.
2. Leggere le istruzioni prima dell'uso.
3. Ispezionare prima dell'uso e sostituire eventuali parti usurate, difettose o mancanti.
4. L'installazione deve essere eseguita solo da adulti e deve essere utilizzato sotto la supervisione di adulti.
5. Posizionare su una superficie piana, controllare che tutte le parti collegate saldamente prima dell'uso.
6. Età adatta: 3+ anni.
7. Solo per uso domestico.
8. Carico totale massimo 50 kg

Questo prodotto deve essere utilizzato solo da persone competenti addestrate e qualificate, in condizioni controllate. L'uso senza un'adeguata supervisione è pericoloso e non dovrebbe mai essere intrapreso né consentito. Il produttore non è ritenuto responsabile per lesioni personali o danni alla proprietà privata causati dall'uso di questo prodotto.

• **Accessory name**

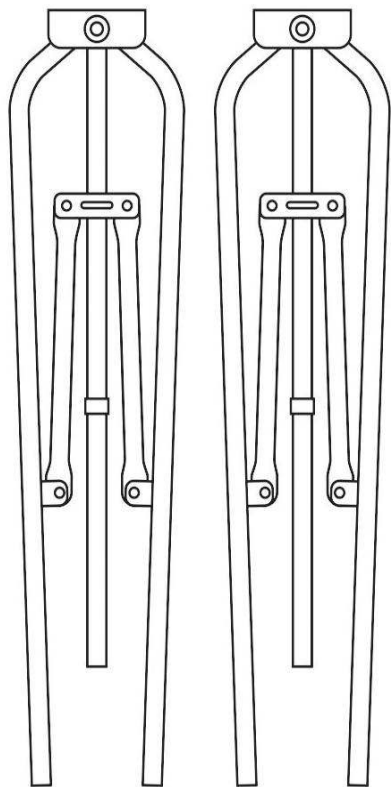

Main shelf: 2parts

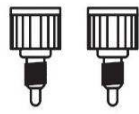

Knob: 2pcs



Adjustment lever: 2pcs

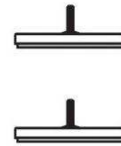

Adjustment disc: 2pcs



Single lever: 1pcs



Base lever: 2pcs

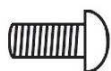

Scerw: 6pcs+spare 1pcs

● **Accessory name**

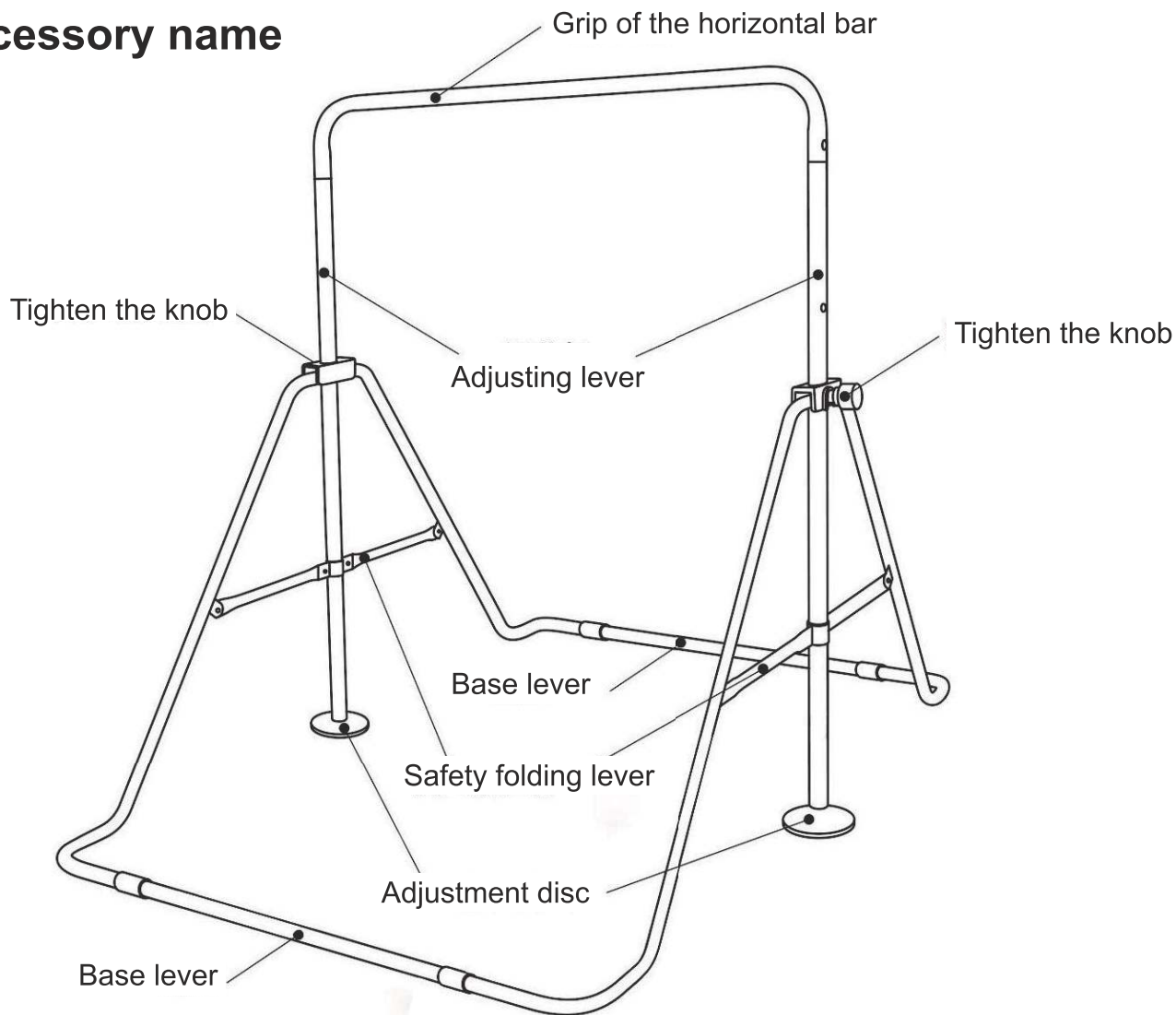

● **Way of assembly**

To ensure safety, it is recommended that 2 people assemble at the same time.

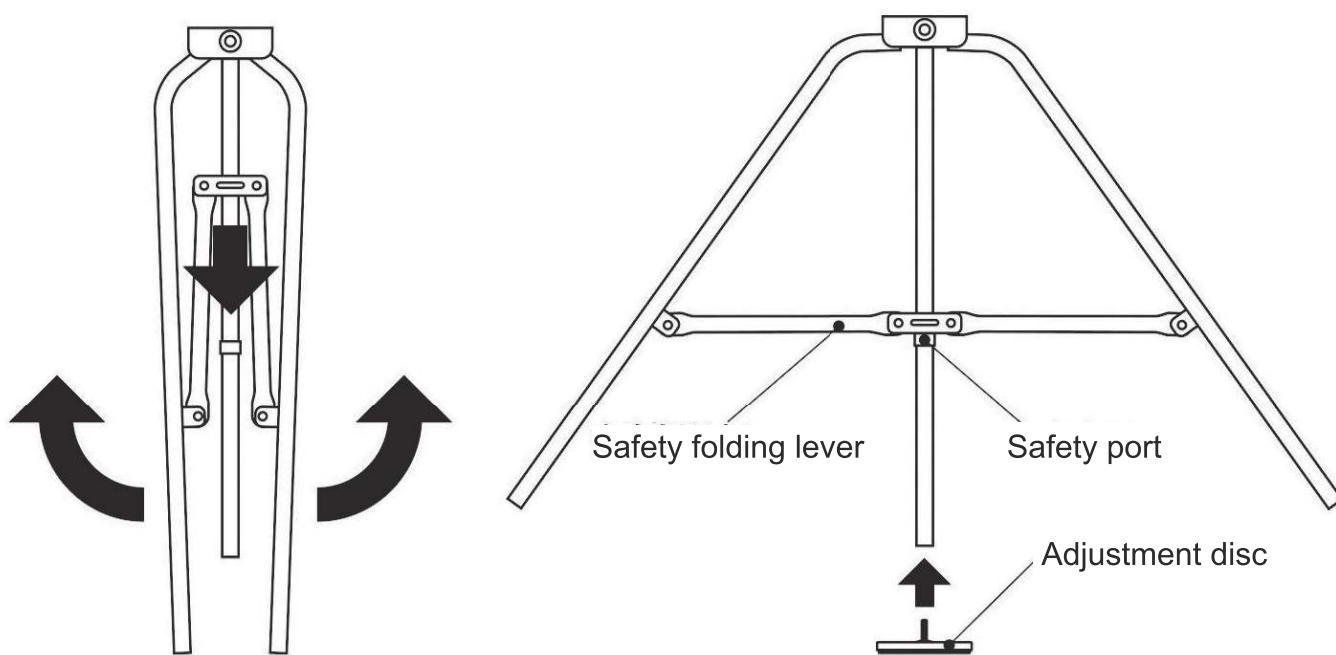

Open the main shelf, screw on the adjusting disc after unfolding (as shown in the figure)

• Way of assembly

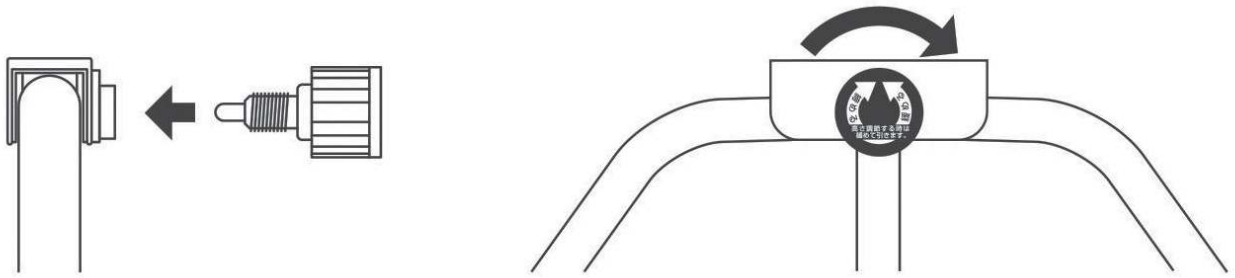

Connect the knob and tighten

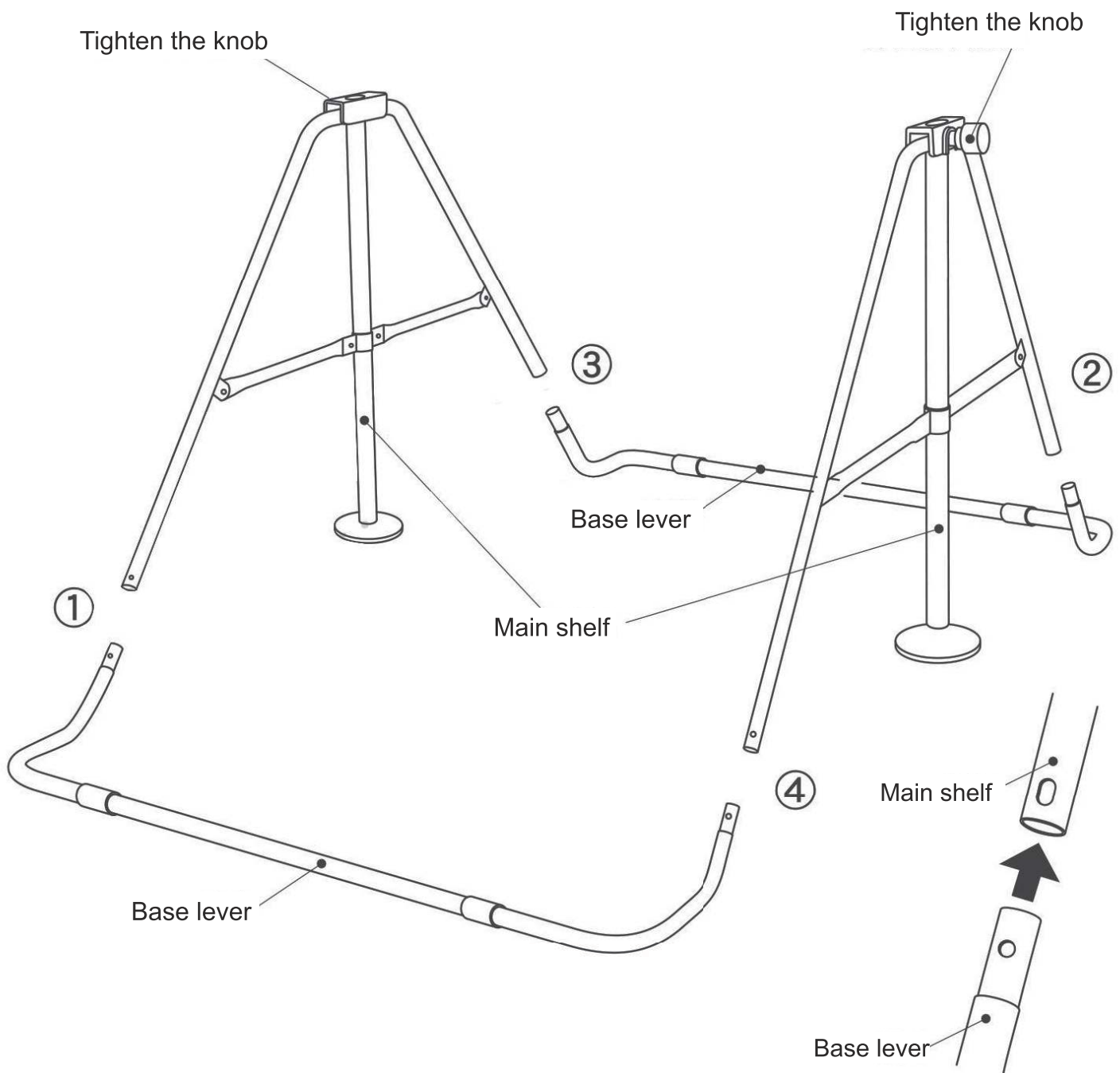

Important: In the direction of the main lever, the tightening knob needs to face the outside, otherwise the horizontal lever cannot be installed with screws. Connect the accessories and tighten the screws.

## • Way of assembly

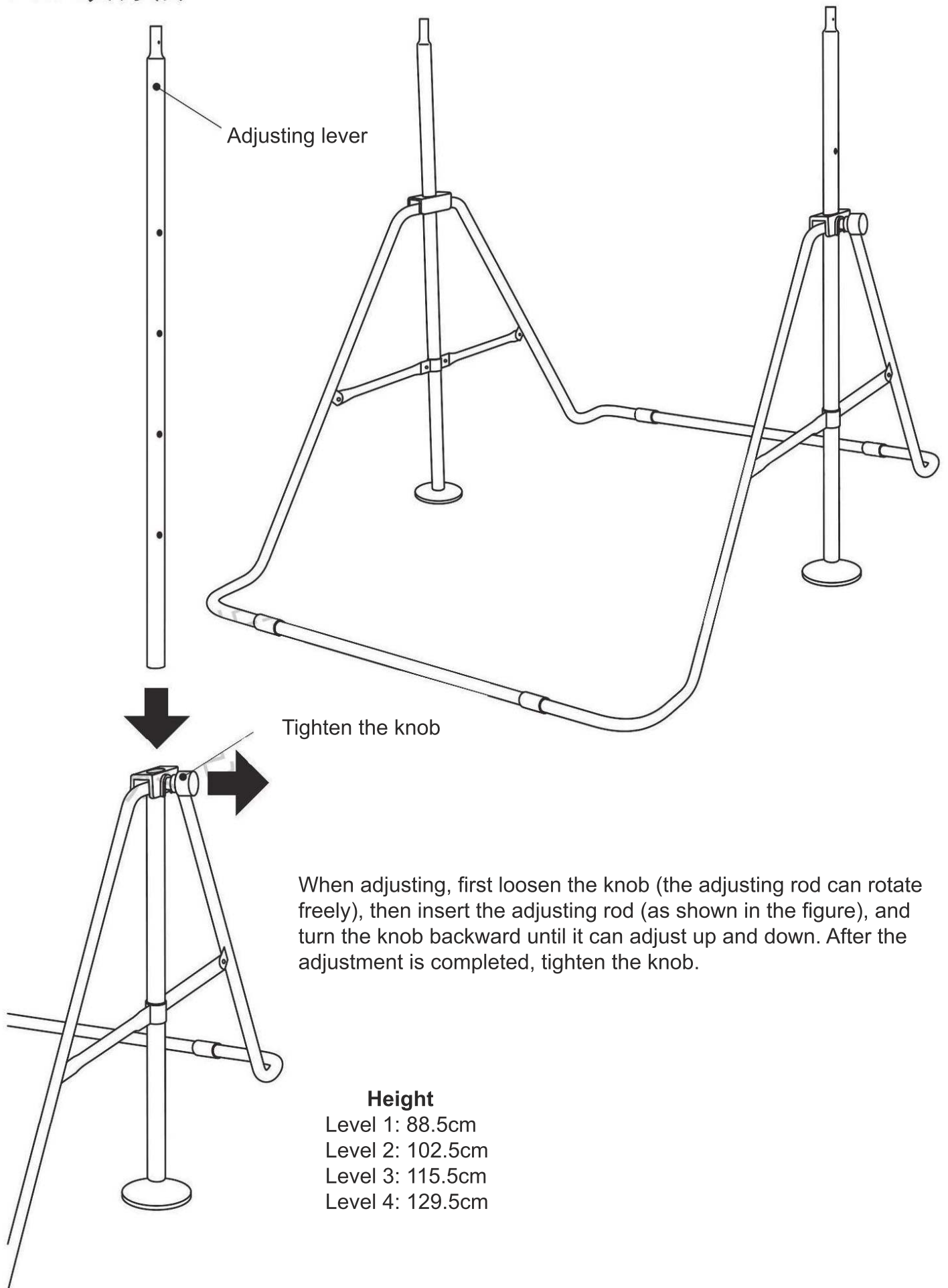

## • Way of assembly

### Adjustment guidelines

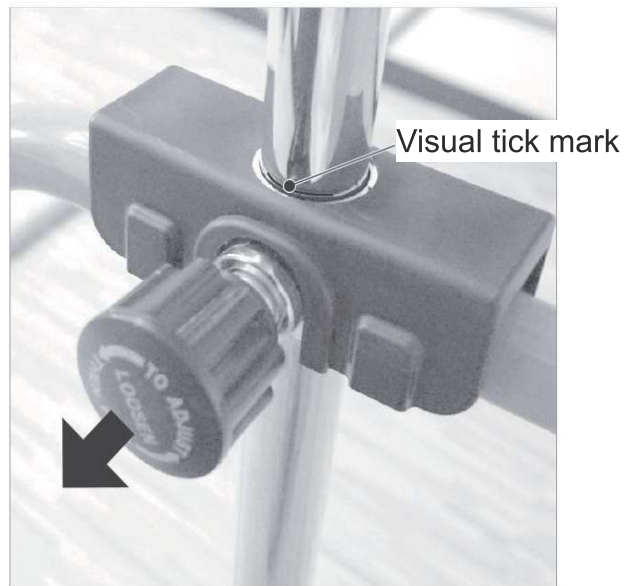
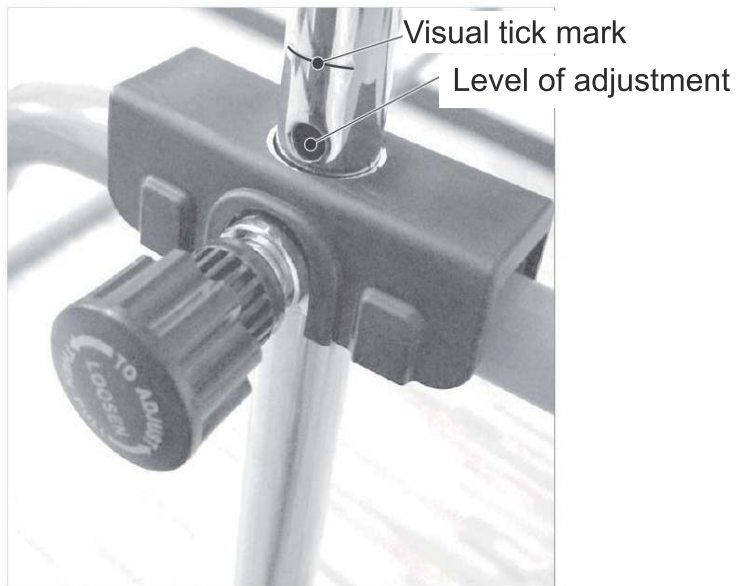

Loosen the knob first, put the adjusting lever into a suitable height and tighten it.

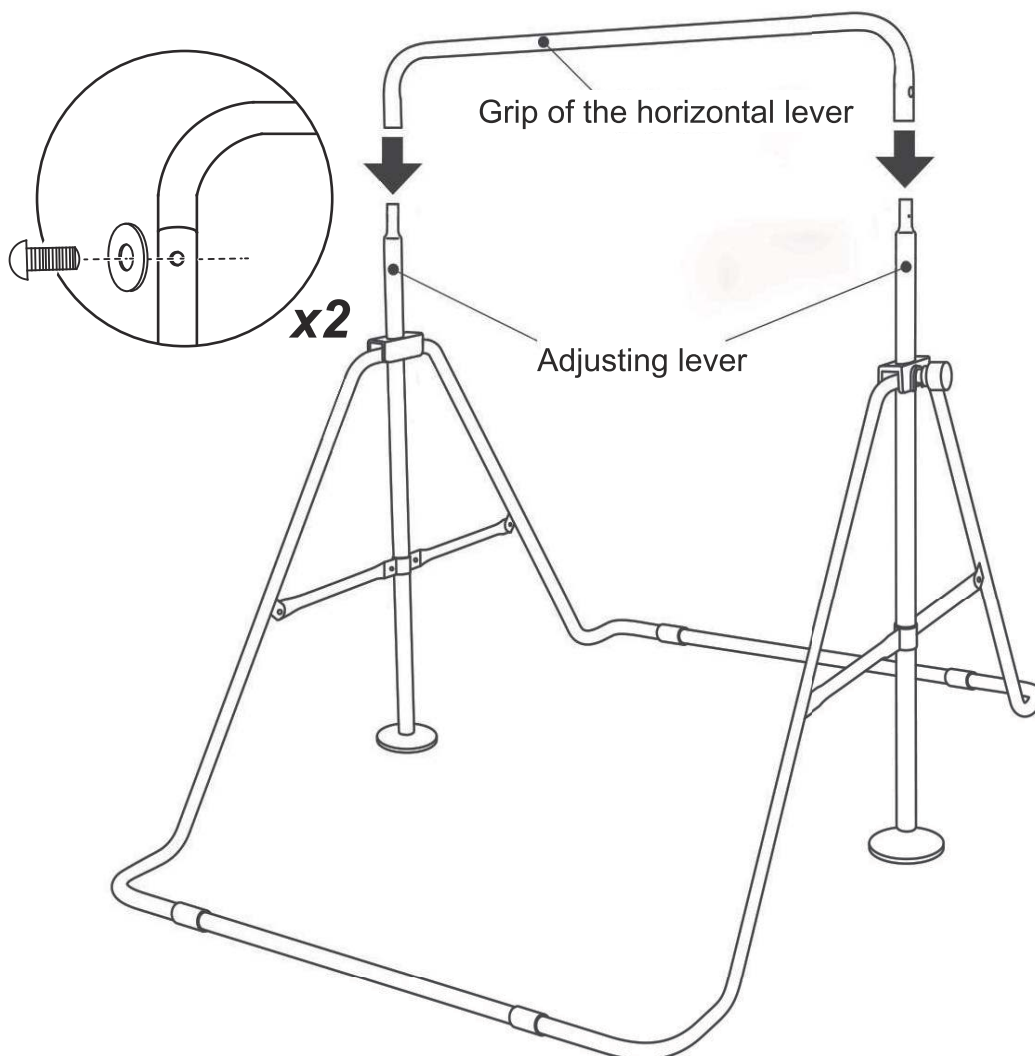

The grip of the horizontal lever is combined with the adjustment bar and locked with screws  
Note: The adjustment knob needs to face outwards, if the adjustment knob faces inward, there will be no corresponding holes.

● Height adjustment

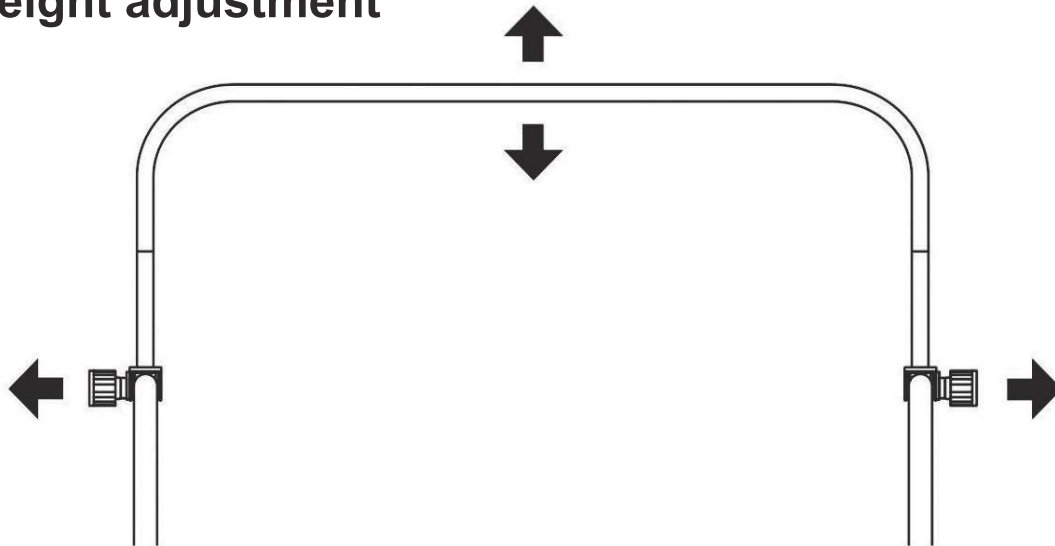

Left and right adjustment knobs: Loosen the knobs on the 2 sides first, when the adjustment lever can be turned, you can adjust the height, and then tighten the knob.

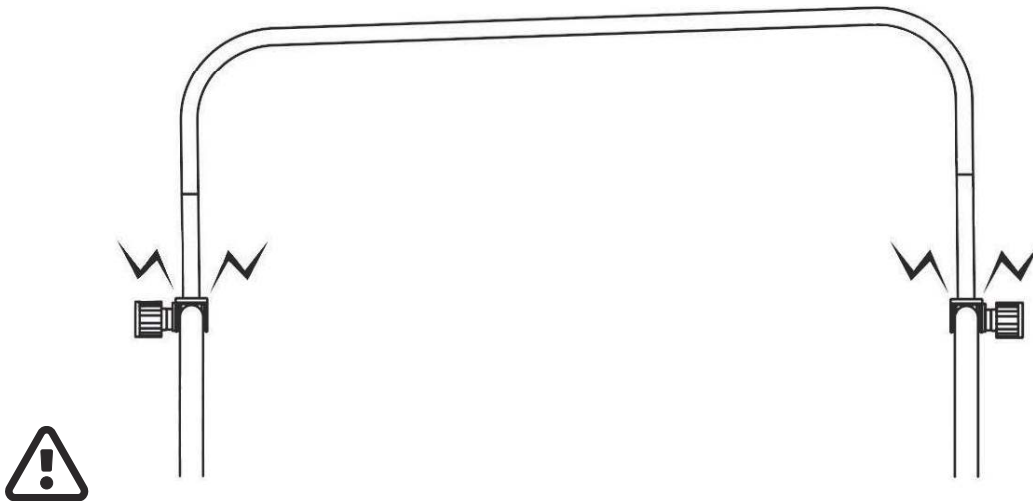

After the adjustment on both sides is at the same height level (there is a scale line on the adjustment rod, and the scale line shall prevail), after the adjustment rods on both sides are raised to the same height at the same time, tighten the knob.

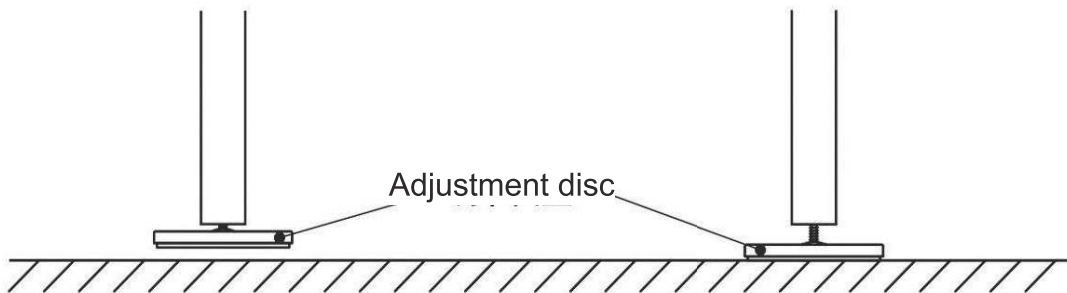

Base disc: when there is a gap with the ground, just rotate and adjust to contact with the ground.



- **Way of folding**

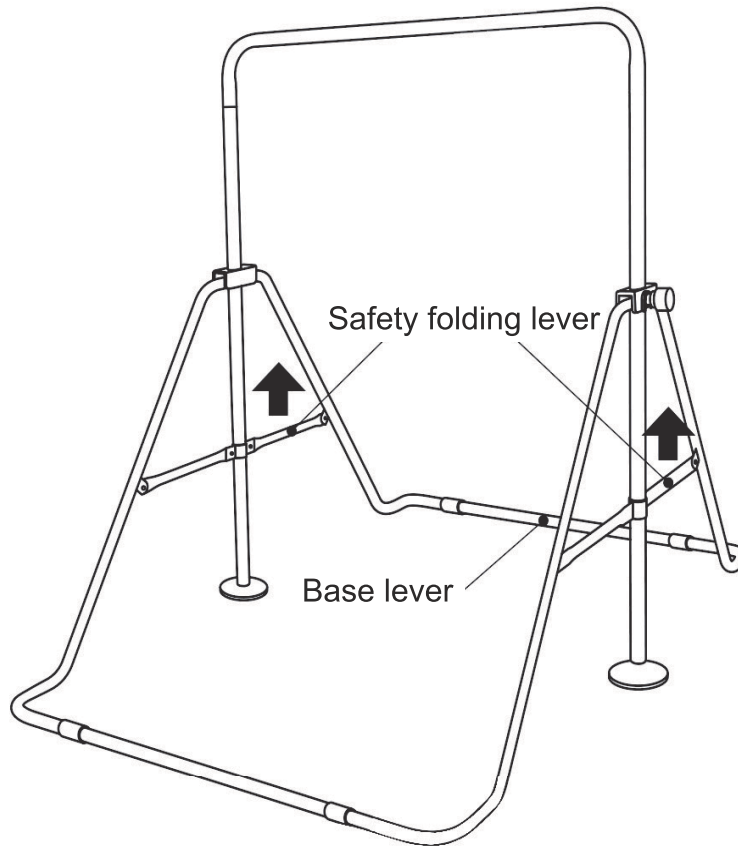

Hold the safety folding lever with both hands at the same time, and pull upwards, the equipment can be folded and closed, as shown in the figure

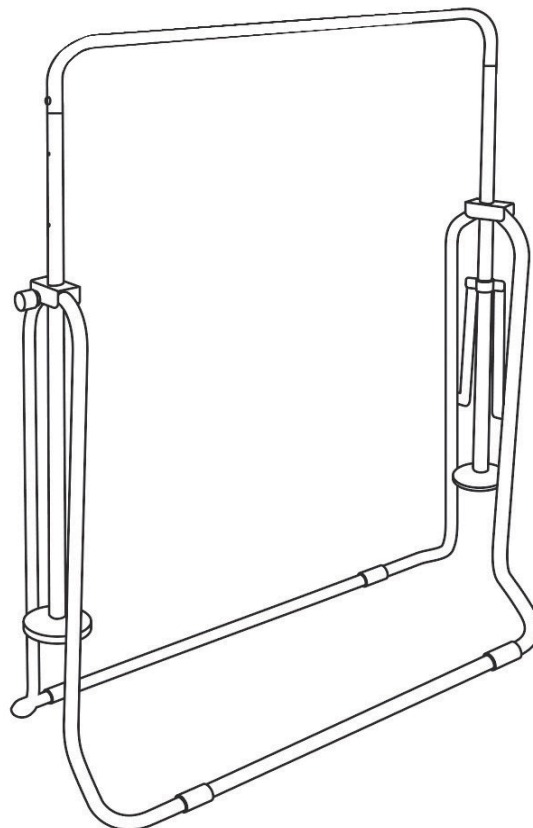

## • Désignation de la pièce

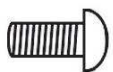
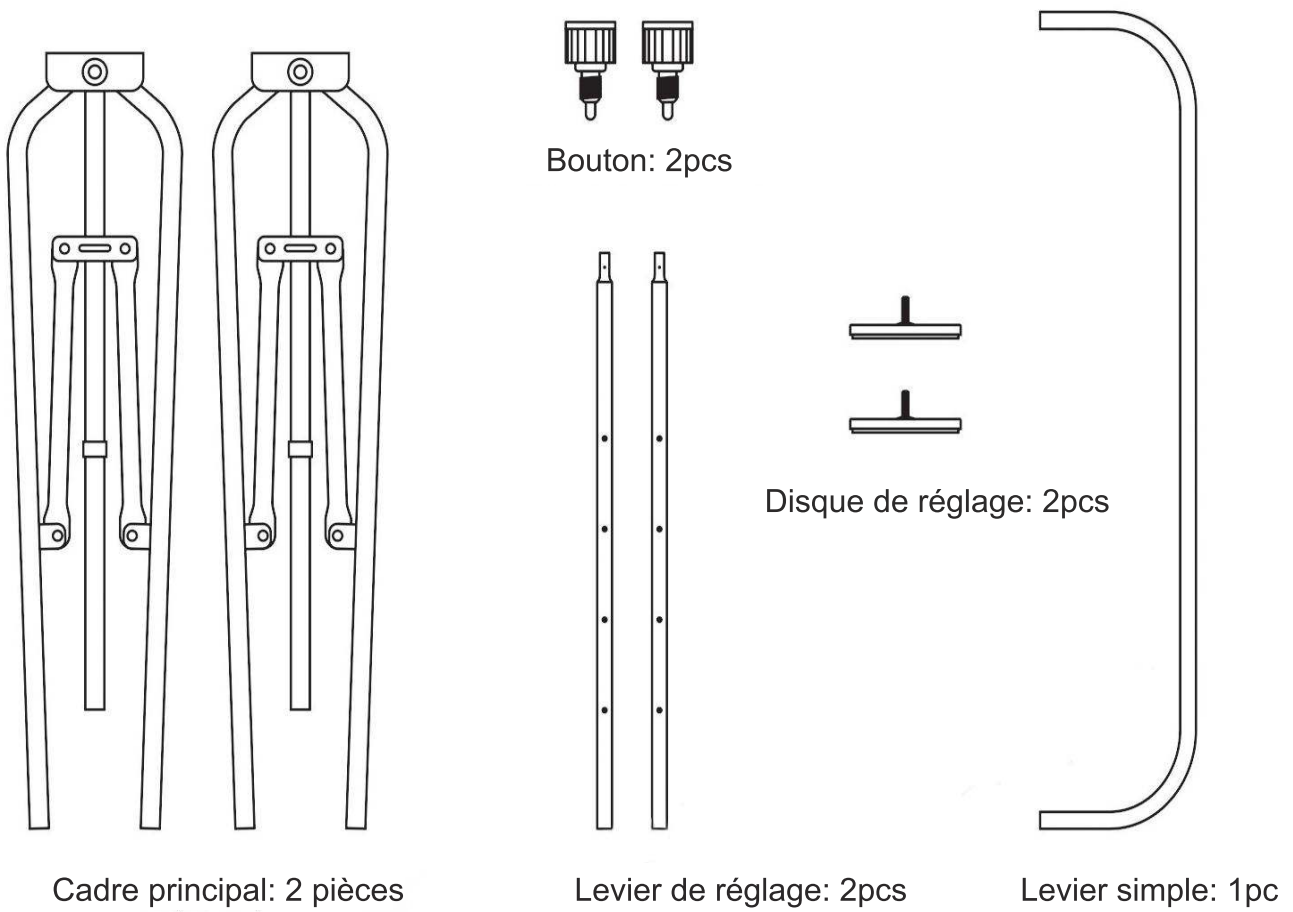

Vis: 6pcs+spare 1pc

Levier de base: 2pcs

## • Désignation de la pièce

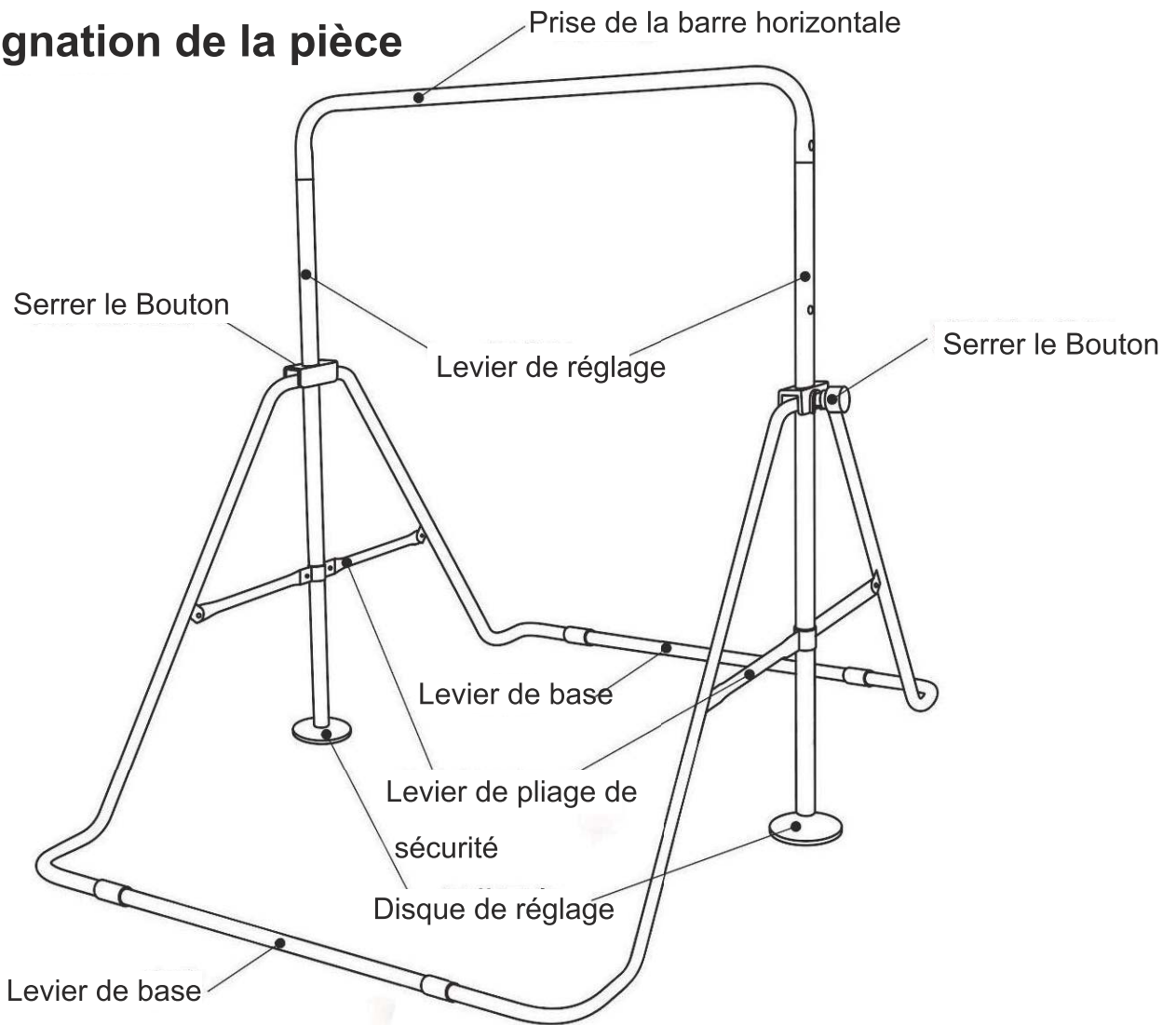

## • Mode de montage

Pour des raisons de sécurité, il est recommandé que 2 personnes effectuent le montage ensemble.

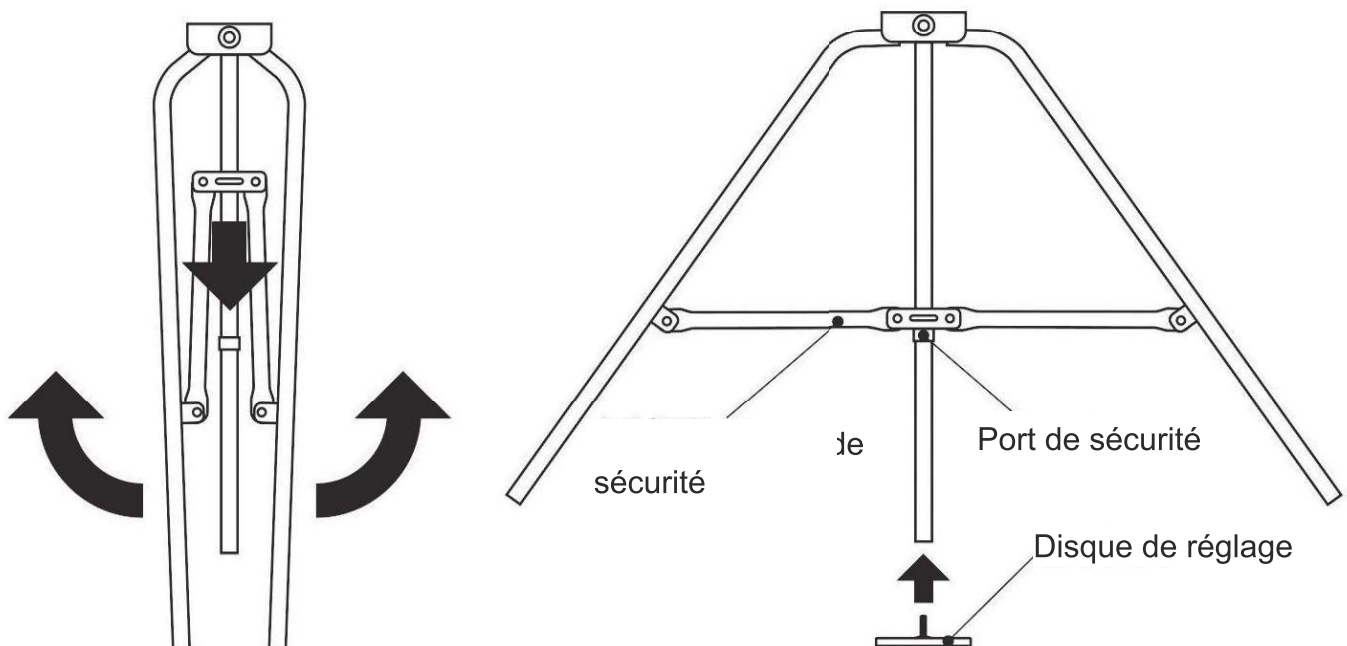

Ouvrez le Cadre principal, vissez le disque de réglage après l'avoir déplié (comme indiqué sur la figure).

## • Mode de montage

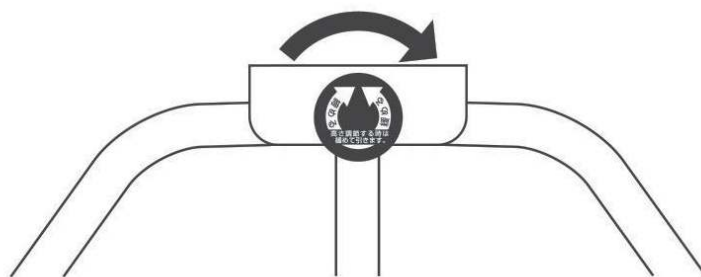
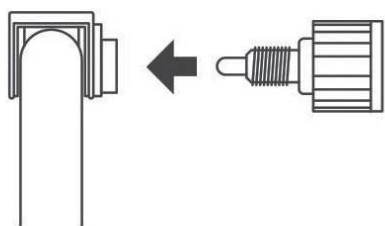

Connecter le Bouton et serrer

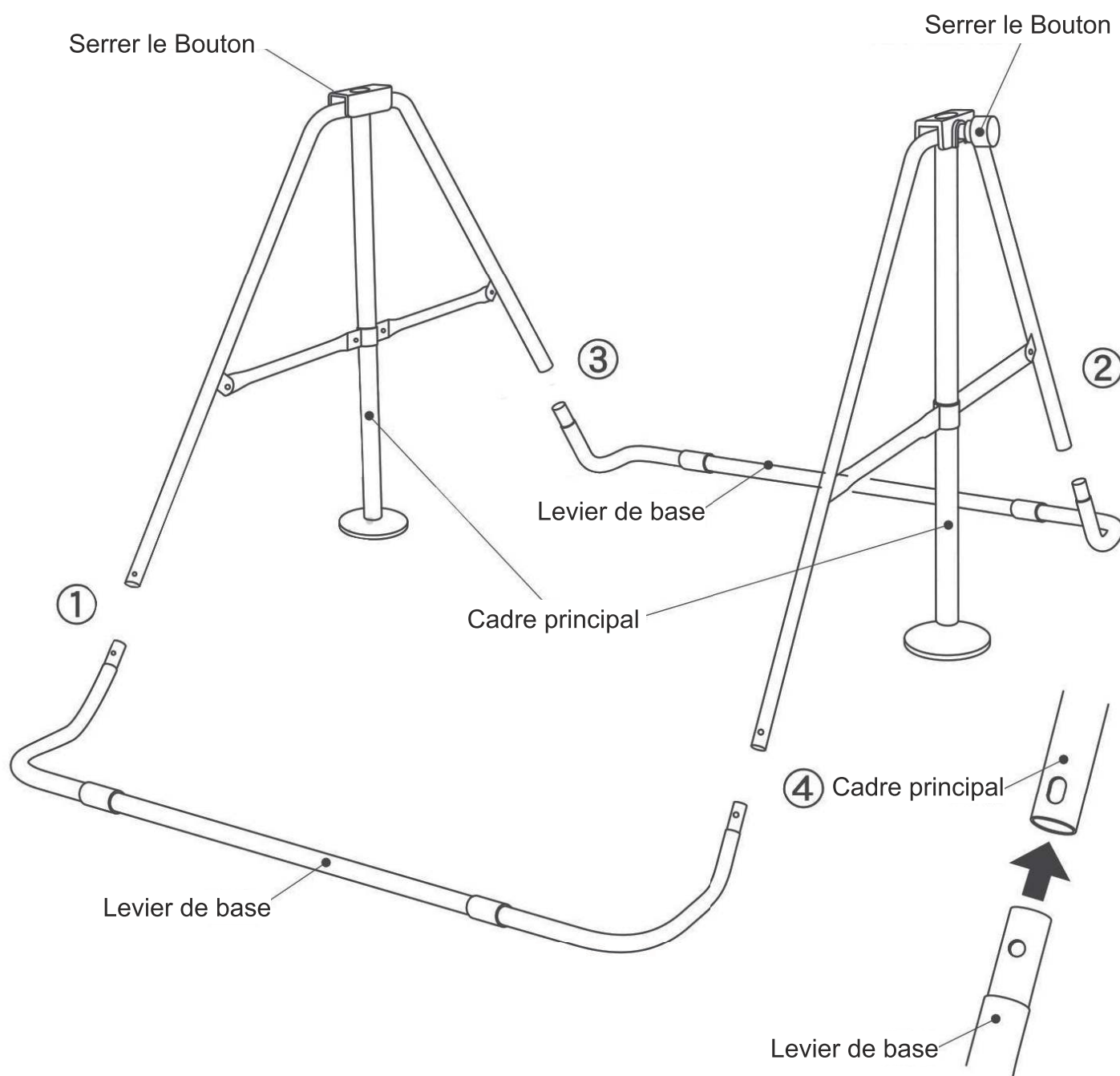

Important: dans le sens du levier principal, le bouton de serrage doit être tourné vers l'extérieur, sinon le levier horizontal ne peut pas être installé avec des vis. Raccordez les accessoires et serrez les vis.

## • Mode de montage

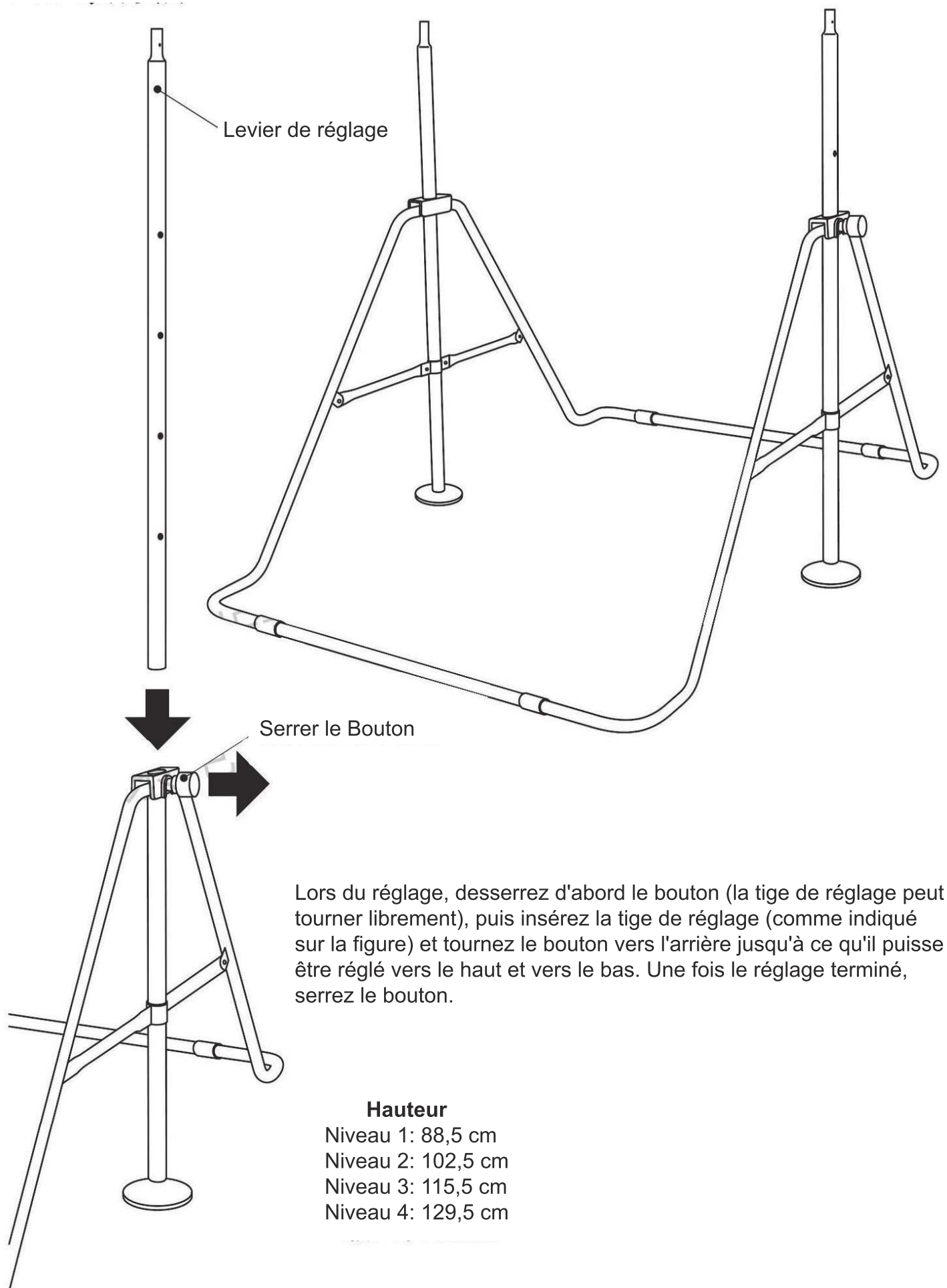

## • Mode de montage

### Directives de réglage

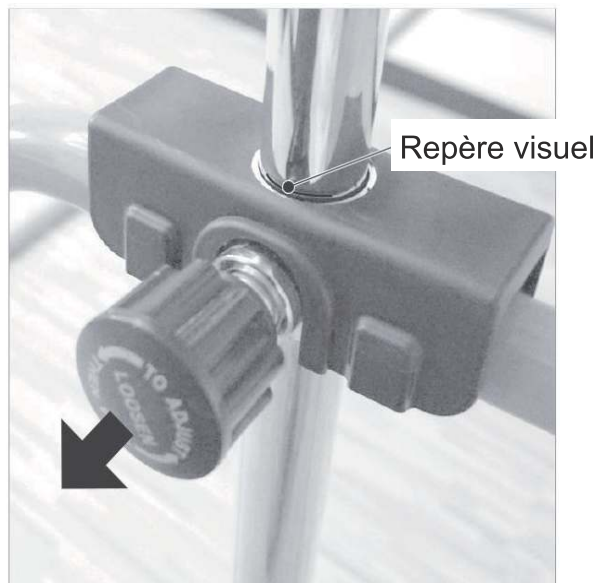
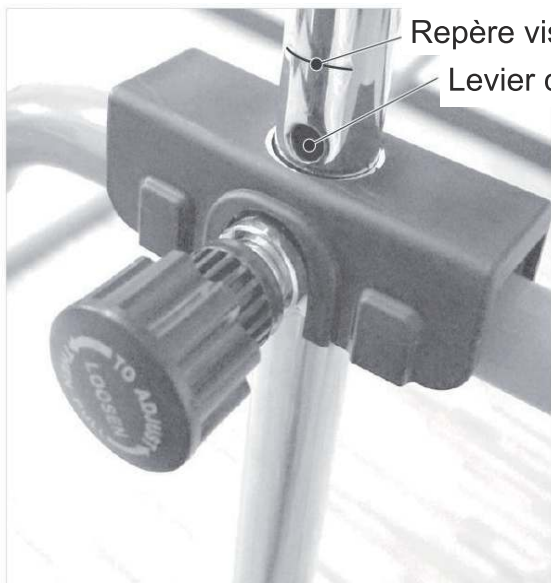

Desserrez d'abord le bouton, placez le levier de réglage à une hauteur appropriée et serrez-le.

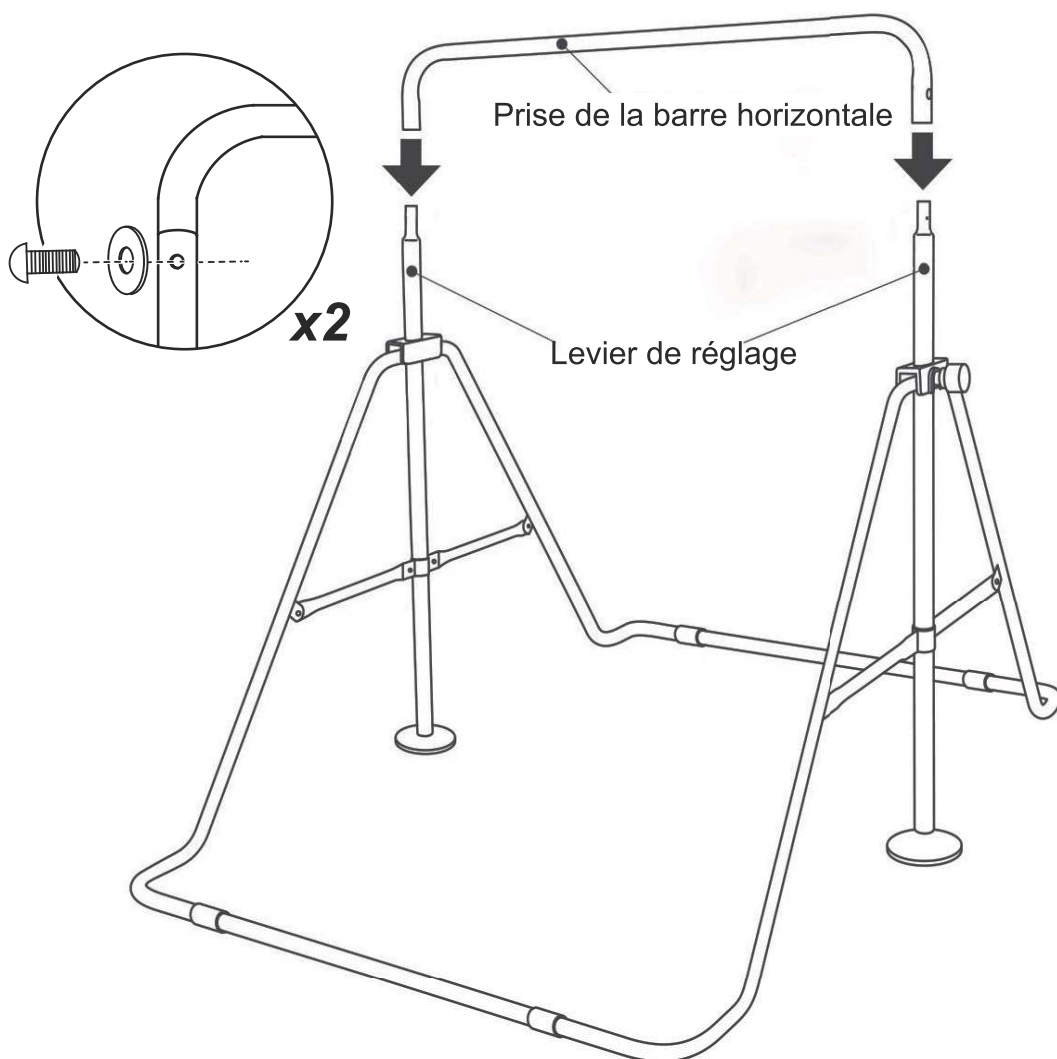

La poignée du levier horizontal est combinée avec la barre de réglage et verrouillée par des vis. Remarque: le bouton de réglage doit être orienté vers l'extérieur, si le bouton de réglage est orienté vers l'intérieur, il n'y aura pas de trous correspondants.

## • Réglage de la hauteur

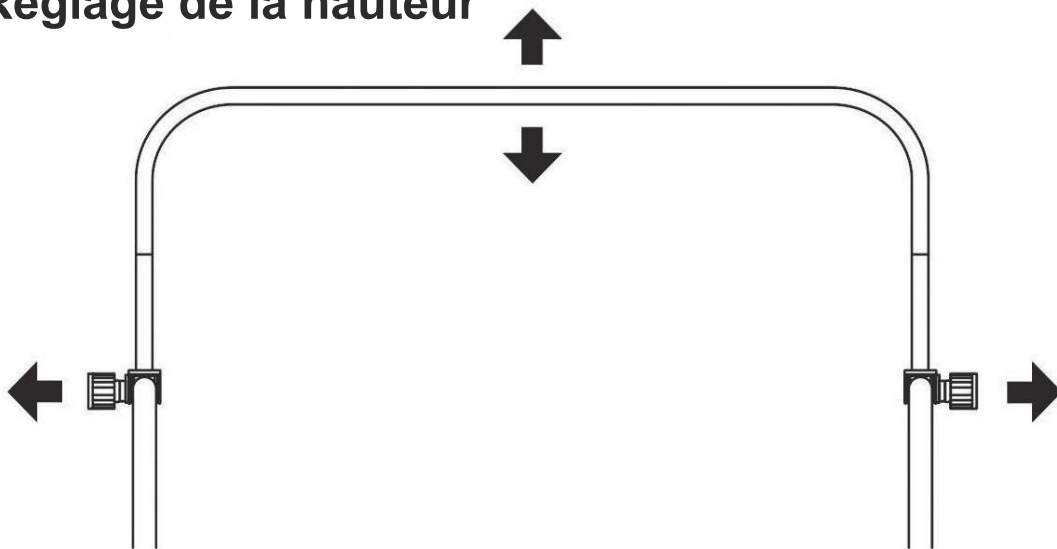

Boutons de réglage gauche et droit: desserrez d'abord les boutons des deux côtés, lorsque le levier de réglage peut être tourné, vous pouvez régler la hauteur, puis resserrez le bouton.

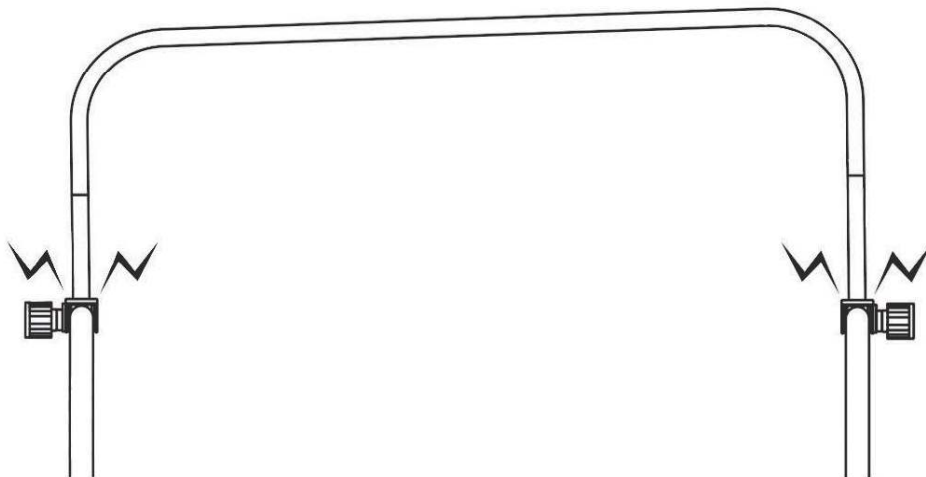

Une fois que le réglage des deux côtés est au même niveau de hauteur (il y a une ligne graduée sur la tige de réglage, et la ligne graduée doit prévaloir), une fois que les tiges de réglage des deux côtés sont levées à la même hauteur en même temps, serrez le bouton.

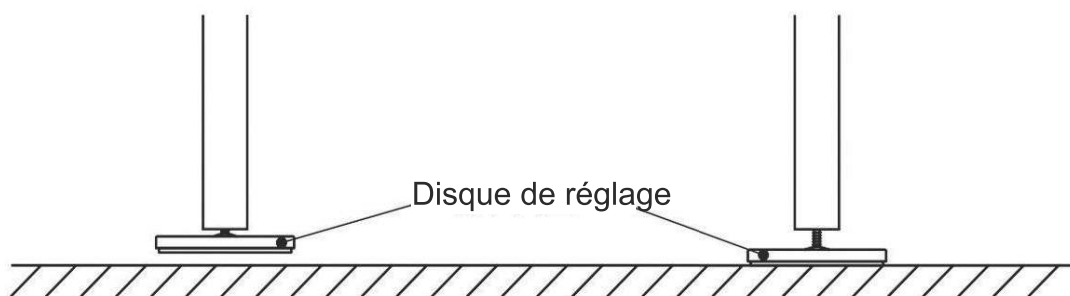

Disque de base: lorsqu'il y a un écart avec le sol, il suffit de le faire tourner et de l'ajuster pour qu'il soit en contact avec le sol.

## • Mode de pliage

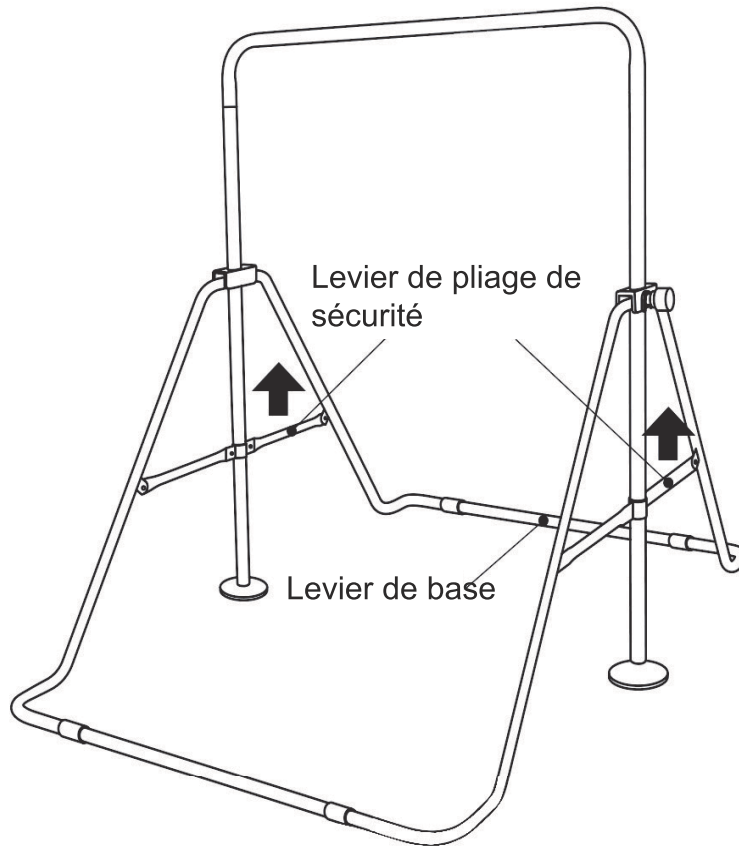

Tenir le levier de pliage de sécurité avec les deux mains en même temps, et tirer vers le haut, l'équipement peut être plié et fermé, comme indiqué sur la figure.

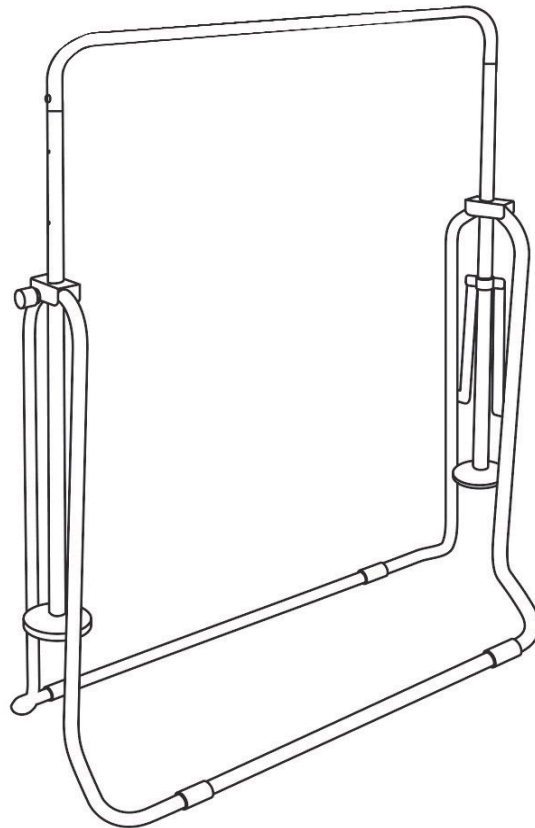



## • Nomi delle Parti

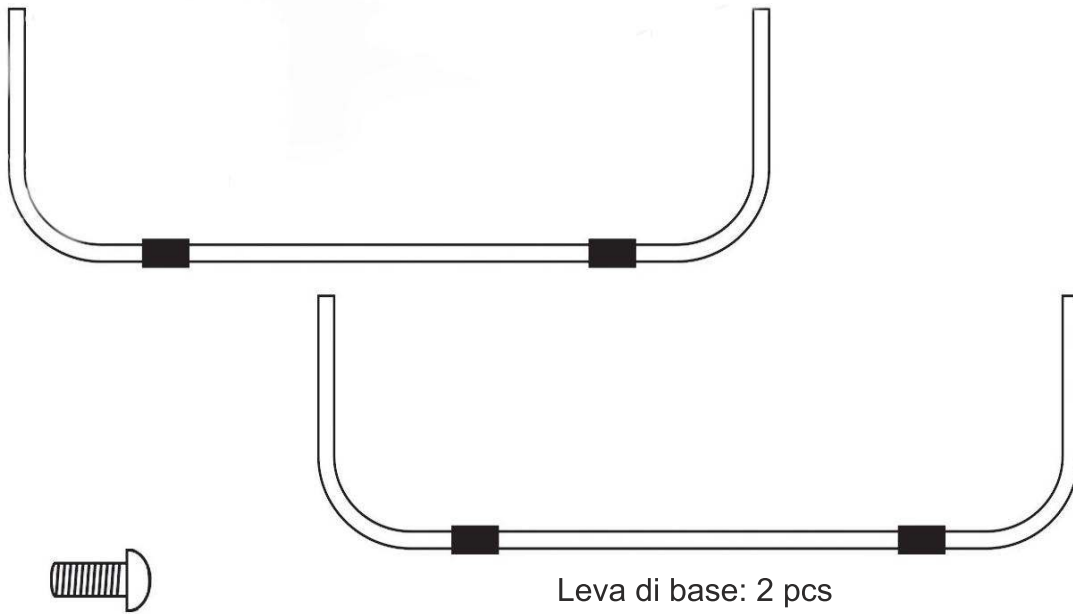
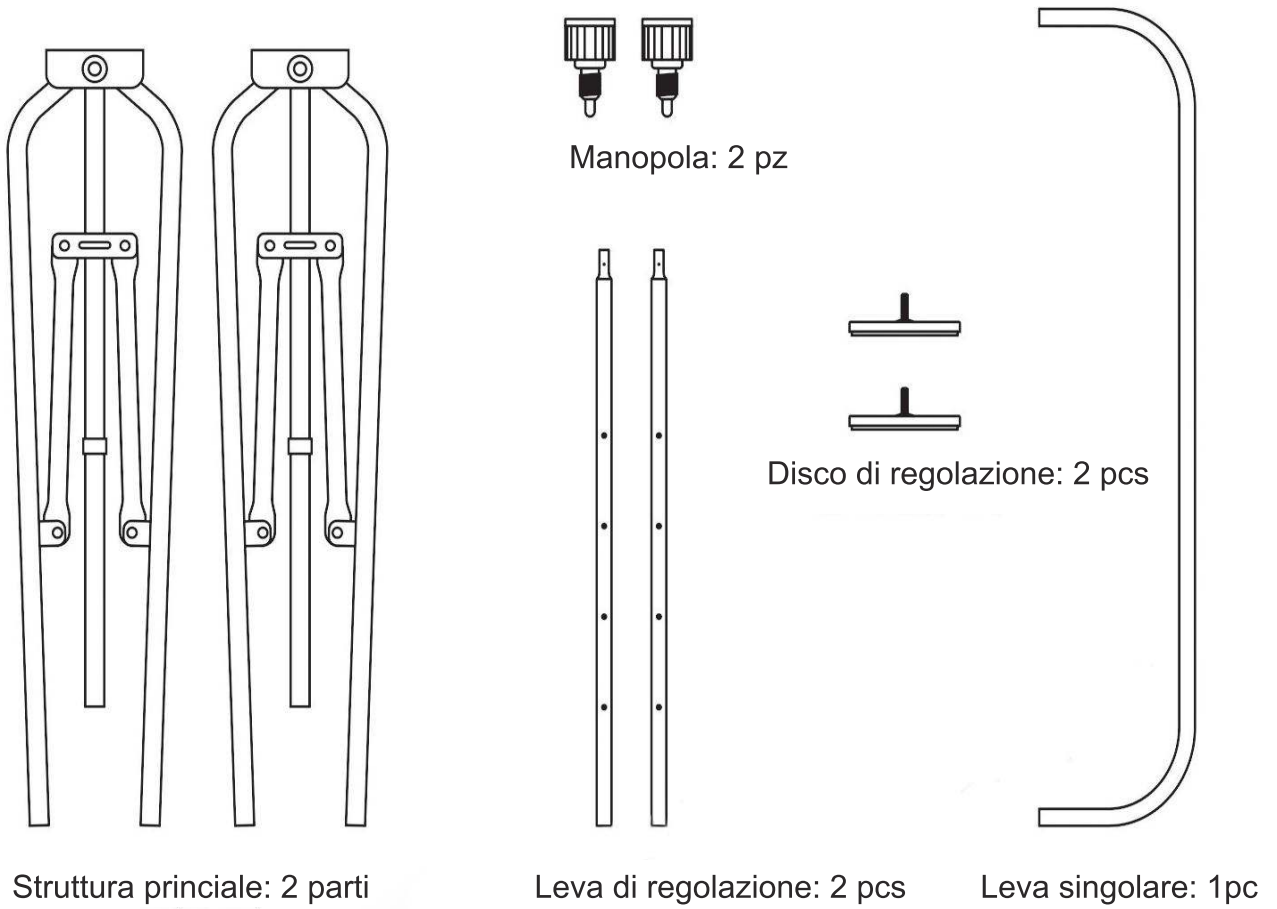

## ● Nomi delle Parti

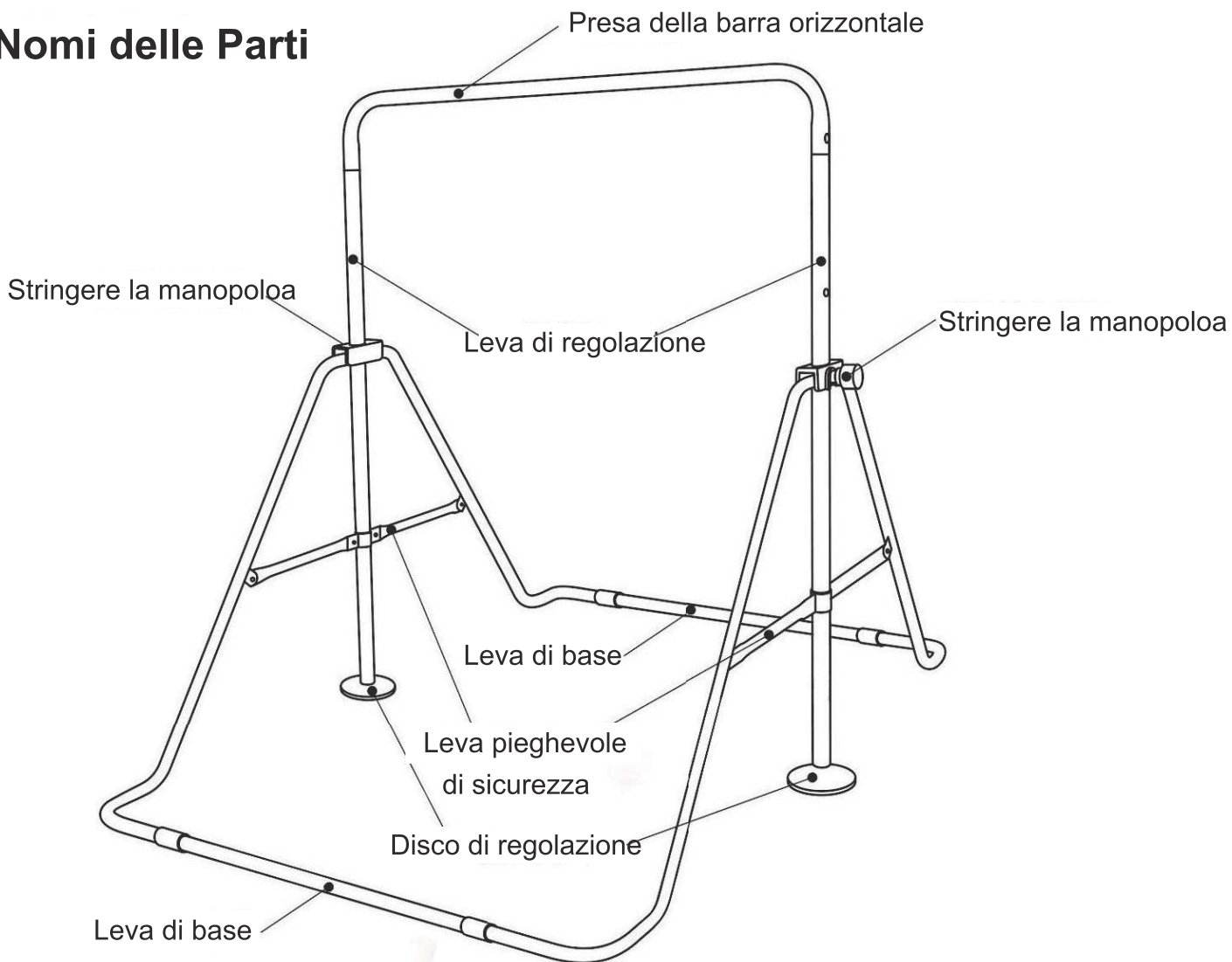

## ● Metodi di Assemblaggio

Per garantire la sicurezza, si consiglia di assemblare con 2 persone contemporaneamente.

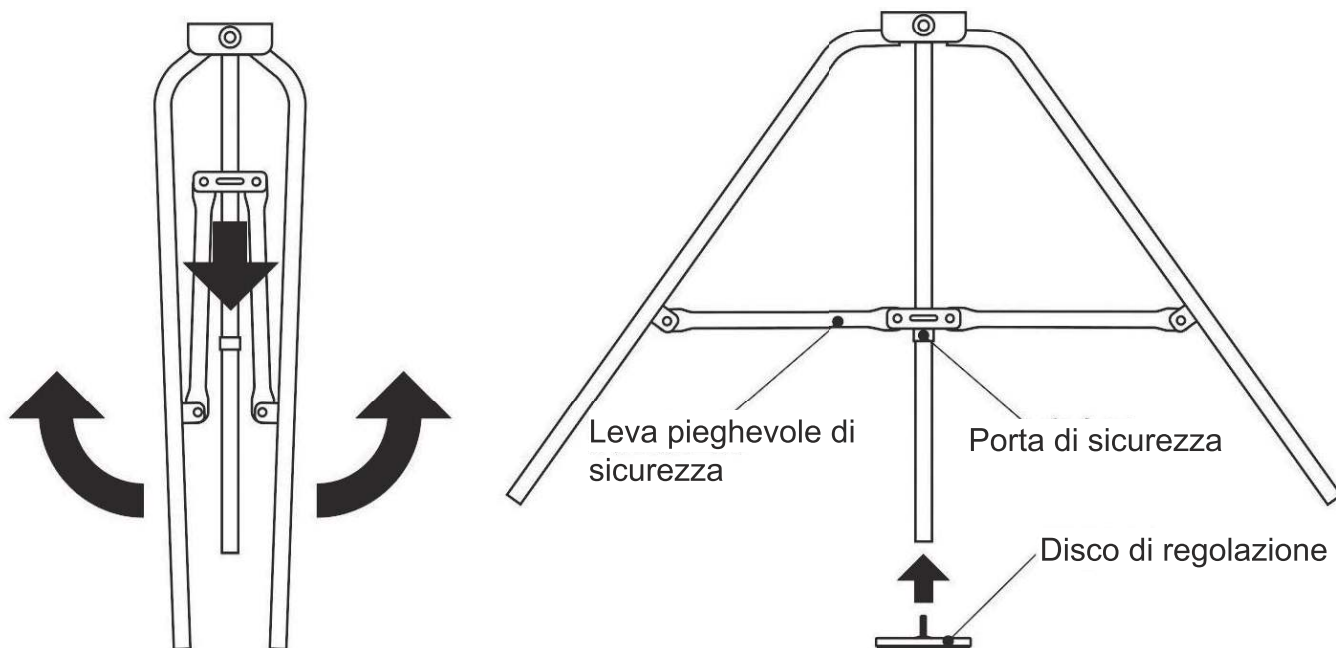

Aprire la struttura principale, avvitare il disco di regolazione dopo averlo aperto (come mostrato nella figura).

## • Metodi di Assemblaggio

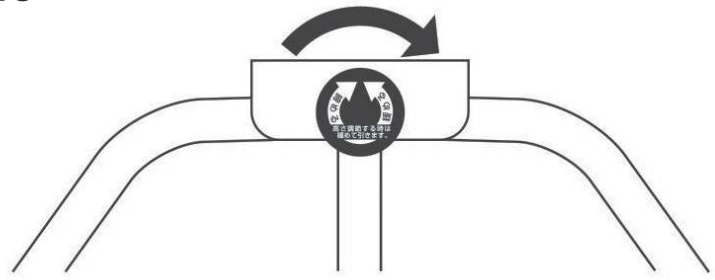
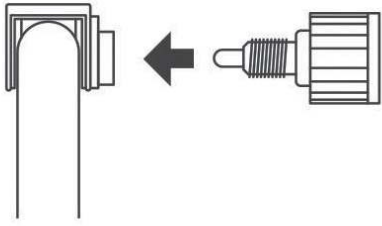

Collegare la manopola e stringerla

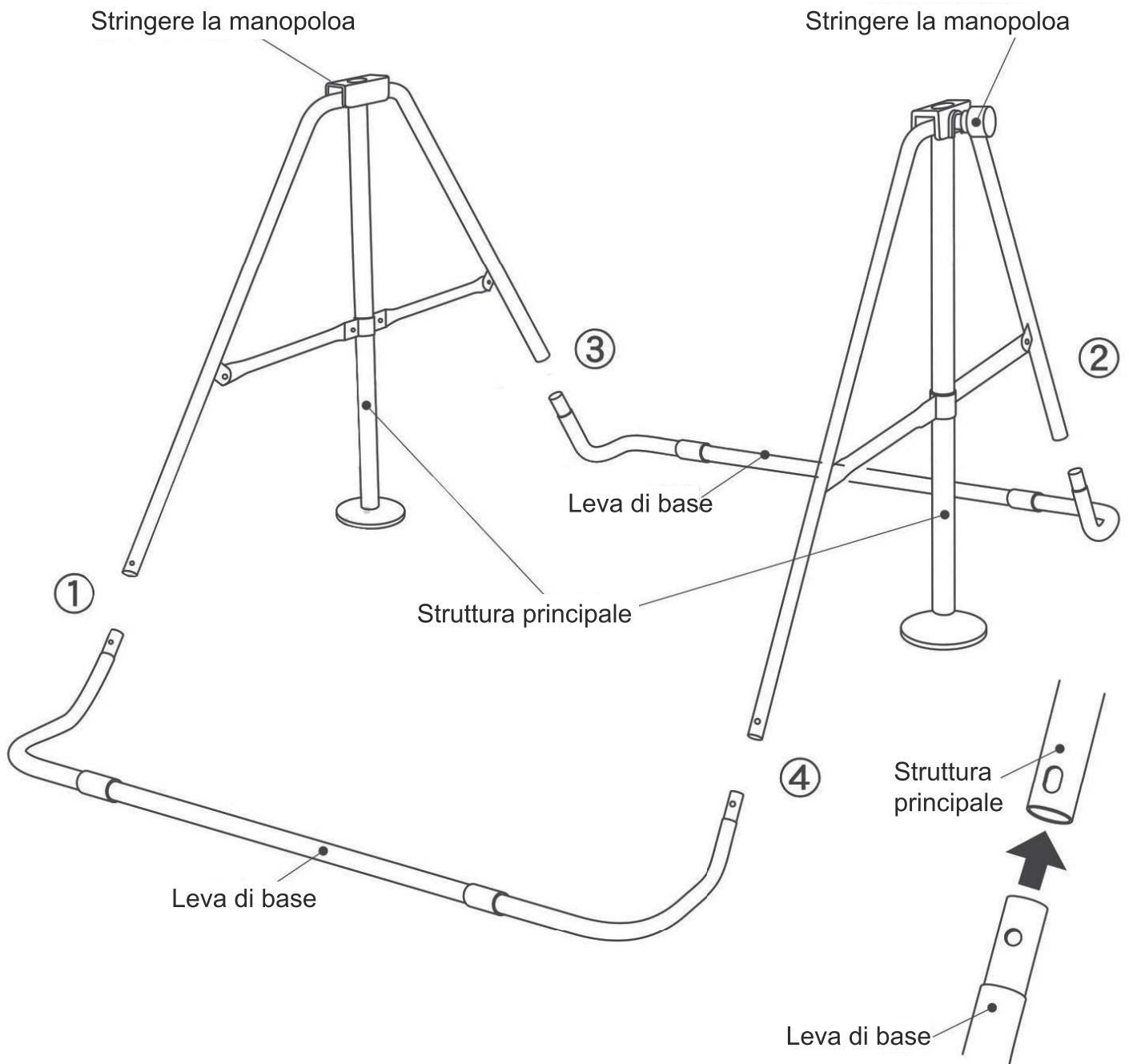

Importante: in direzione della leva principale, la manopola di serraggio deve essere rivolta verso l'esterno, altrimenti la leva orizzontale non può essere installata con le viti. Collegare le parti e serrare le viti.

## ● Metodi di Assemblaggio

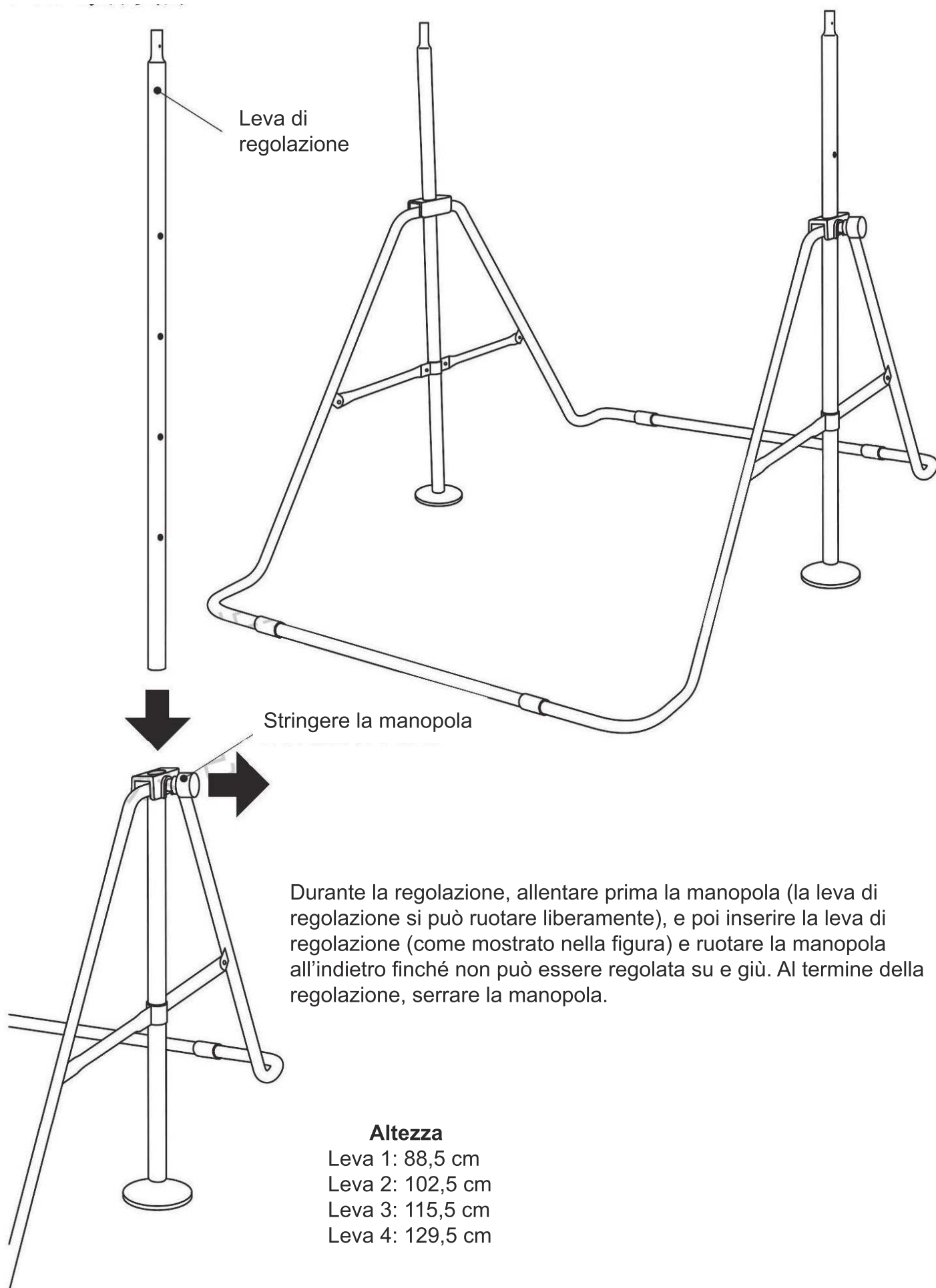

## ● Metodi di Assemblaggio

### Istruzioni per la regolazione



Allentare prima la manopola, posizionare la leva di regolazione ad un'altezza adeguata e serrarla.

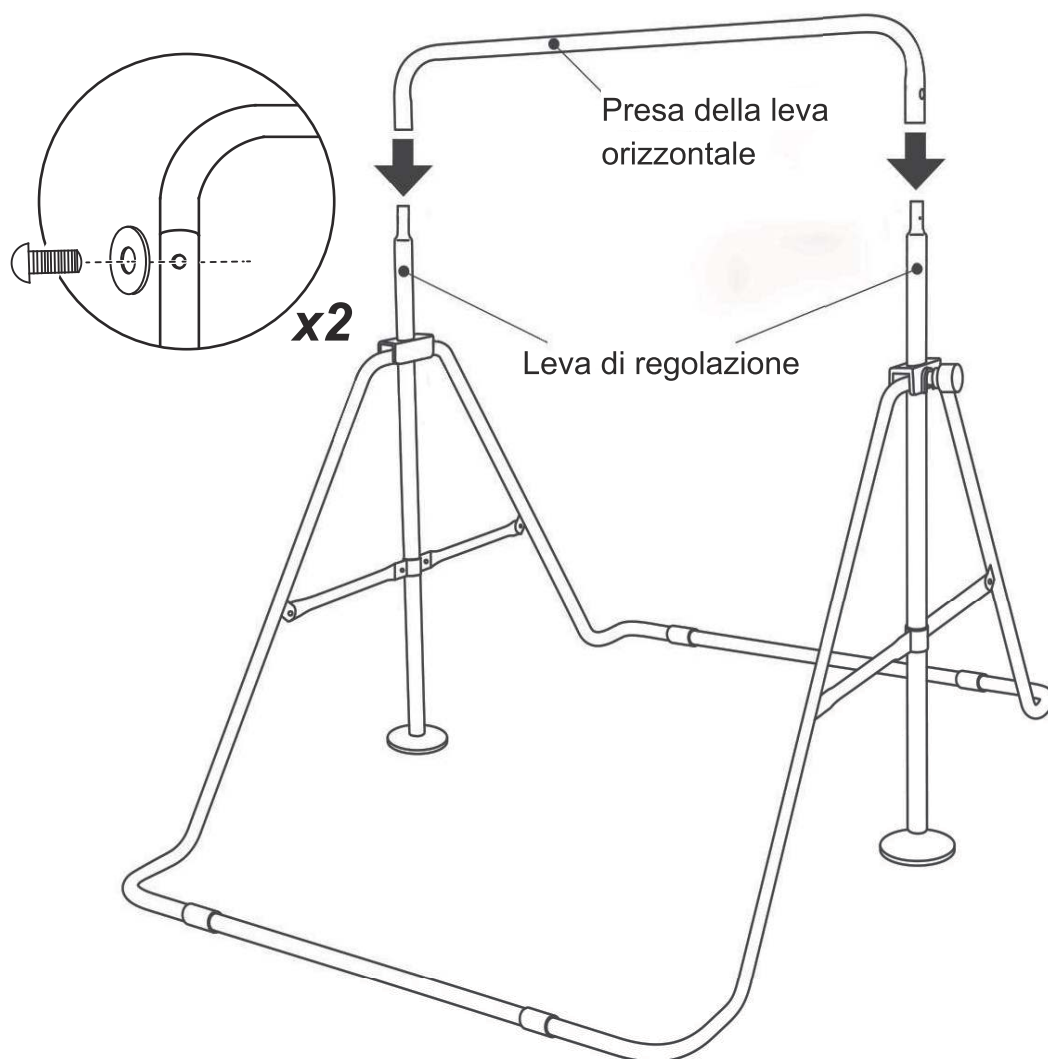

La presa della leva orizzontale è abbinata alla barra di regolazione e bloccata con viti.  
Nota: la manopola di regolazione deve essere rivolta verso l'esterno, se la manopola di regolazione è rivolta verso l'interno, non ci saranno fori corrispondenti.

## • Regolazione in altezza

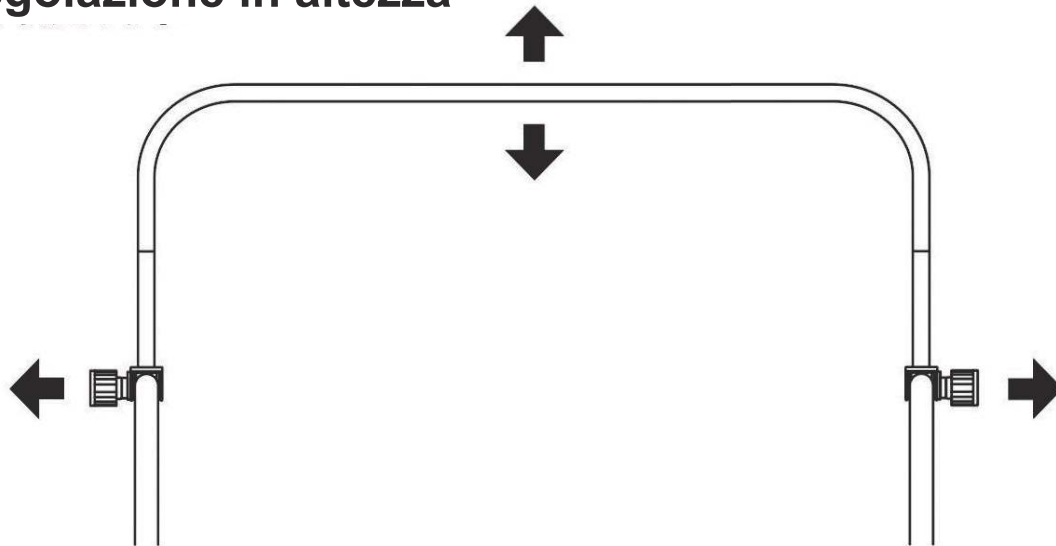

Manopole di regolazione sinistra e destra: allentare prima le manopole sui 2 lati, quando la leva di regolazione può essere ruotata, è possibile regolare l'altezza, e poi serrare la manopola.

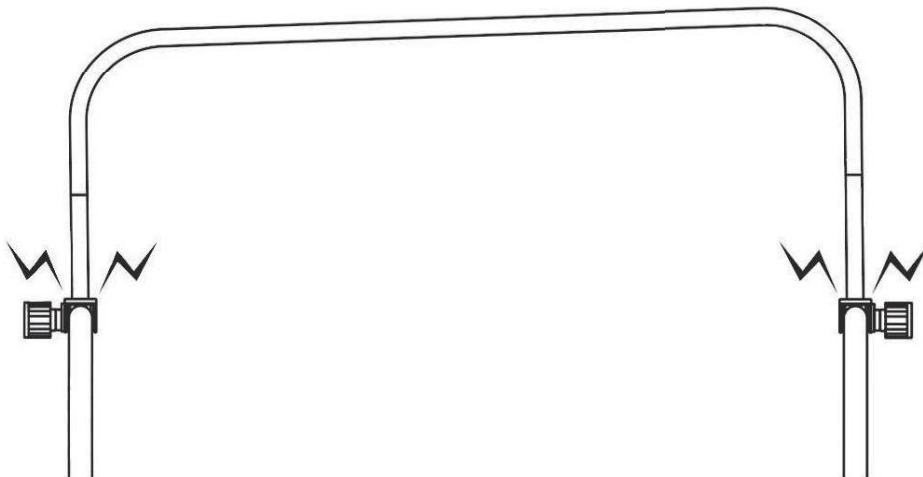

Dopo che la regolazione su entrambi i lati fino allo stesso livello di altezza (c'è una linea di scala sulla leva di regolazione e la linea di scala deve prevalere), dopo che le leve di regolazione su entrambi i lati sono state sollevate alla stessa altezza contemporaneamente, stringere la manopola.

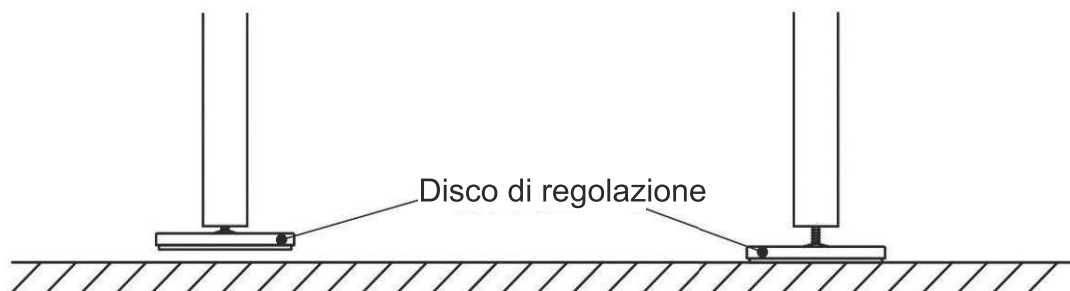

Disco di base: quando c'è una distanza fra il disco e il terreno, basta ruotare e regolarlo a contatto con il terreno.

## ● Metodo di Piegatura

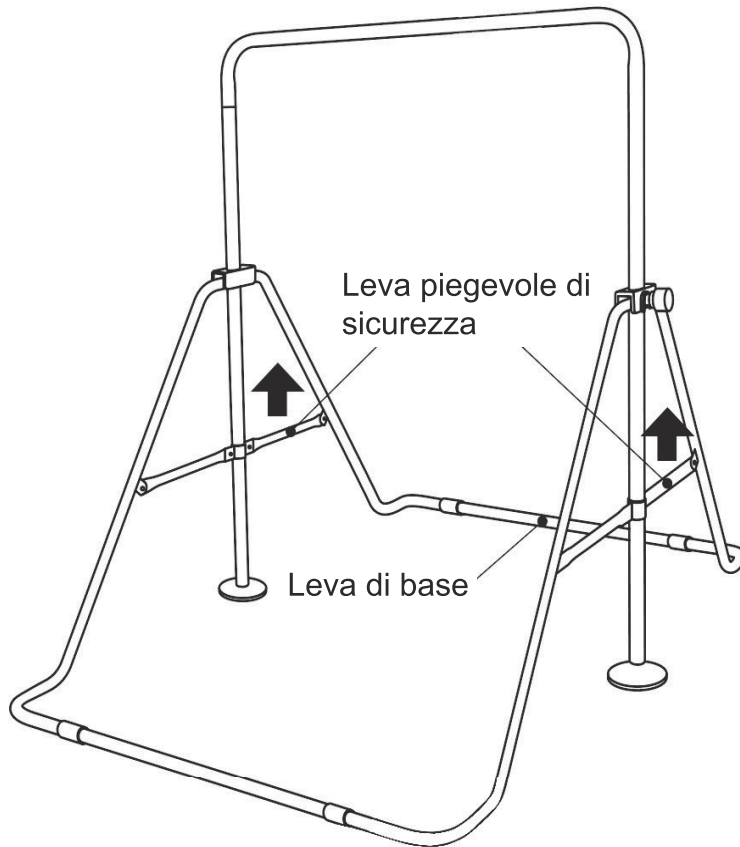

Afferrare contemporaneamente la leva di chiusura di sicurezza con entrambe le mani e tirare verso l'alto, l'attrezzatura può essere piegata e chiusa, come mostrato in figura.

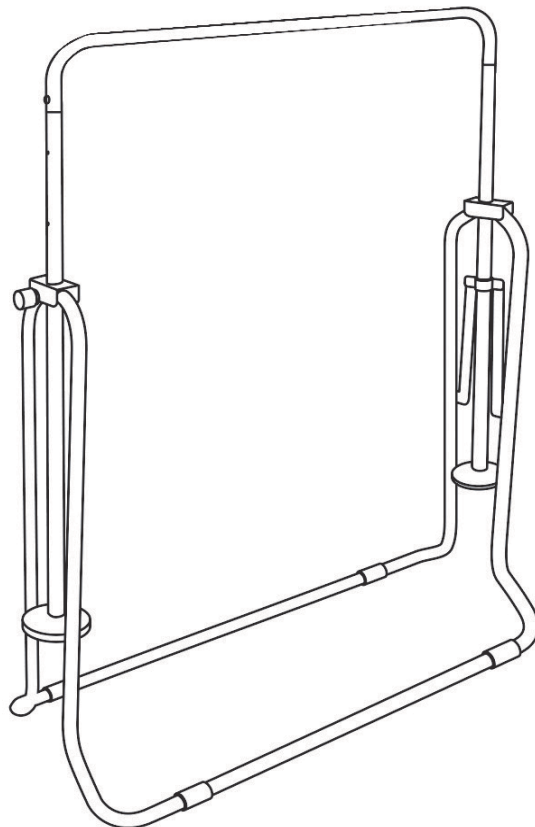

**UK**

If you have any questions, please contact our customer care center.

Our contact details are below:



0044-800-240-4004



enquiries@mhstar.co.uk

IMPORTER ADDRESS:

MH STAR UK LTD

Unit 27, Perivale Park,

Horsenden lane South

Perivale, UB6 7RH

MADE IN CHINA

**ES**

Si tiene alguna pregunta, comuníquese con nuestro Centro de Atención al Cliente.

Nuestros datos de contacto son los siguientes:



0034-931294512



atencioncliente@aosom.es

IMPORTADOR:

SPANISH AOSOM, S.L.

C/ ROC GROS, N° 15. 08550, ELS HOSTALETES DE

BALENYÀ, SPAIN.

B66295775

WWW.AOSOM.ES

ATENCIONCLIENTE@AOSOM.ES

TEL: 931294512

HECHO EN CHINA

**FR**

Si vous avez la moindre question, veuillez contacter notre centre d'assistance à la clientèle.

Nos coordonnées sont les suivantes:



0033-1-84166106



aosom@mhfrance.fr

Importé par:

MH France

2, rue Maurice Hartmann

92130 Issy-les-Moulineaux

France

Fabriqué en Chine

**PT**

Se tiver alguma dúvida, por favor contacte o nosso Centro de Atendimento ao Cliente.

Os nossos dados de contacto são os seguintes:



0034-931294512



info@aosom.pt.

IMPORTADOR:

SPANISH AOSOM, S.L

C.ROC GROS N.15, 08550. ELS HOSTALETES DE BALENYÀ

TEL: 931294512 (SEG-SEX DAS 7:30H ÀS 16:30H)

INFO@AOSOM.PT

WWW.AOSOM.PT

**DE**

Wenn Sie Fragen haben, wenden Sie sich bitte an unser Kundendienstzentrum.

Unsere Kontaktdaten stehen unten:



0049-0(40)-88307530



service@aosom.de

ADRESSE DES IMPORTEURE:

MH Handel GmbH

Wendenstraße 309

D-20537 Hamburg

Germany

IN CHINA HERGESTELLT

**IT**

In caso di dubbio, si prega di contattare il nostro centro assistenza clienti.

I nostri dettagli di contatto sono di seguito:



0039-0249471447



clienti@aosom.it

IMPORTATO DA:

AOSOM Italy srl

Centro Direzionale Milanofiori

Strada 1 Palazzo F1

20057 Assago (MI)

P.I.: 08567220960

FATTO IN CINA