

# PawHut

IN231000639V02\_GL

**D00-193V00**

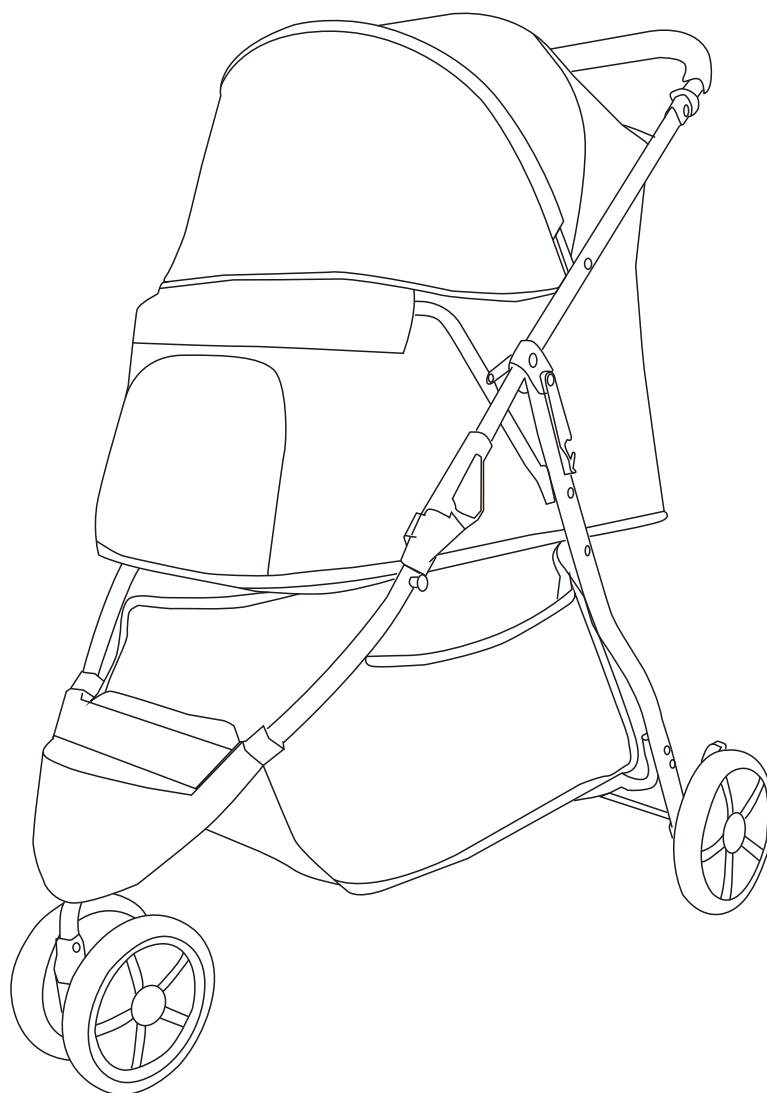

**EN\_IMPORTANT, RETAIN FOR FUTURE REFERENCE: READ CAREFULLY.**

**FR\_IMPORTANT: A LIRE ATTENTIVEMENT ET À CONSERVER POUR CONSULTATION ULTÉRIEURE.**

**ES\_IMPORTANTE, LEA Y GUARDE PARA FUTURAS REFERENCIAS.**

**PT\_IMPORTANTE, RETER PARA REFERÊNCIA FUTURA: LEIA ATENTAMENTE.**

**DE\_WICHTIG! SORGFÄLTIG LESEN UND FÜR SPÄTER NACHSCHLAGEN AUFBEWAHREN.**

**IT\_IMPORTANTE! CONSERVARE IL PRESENTE MANUALE PER FUTURO RIFERIMENTO E LEGGERLO ATTENTAMENTE.**

**WARNING:Keep Away From Fire**

- 1.Please read this instruction carefully before use and keep it properly for future reference. If you do not follow this instruction, the safety of pets may be affected.
- 2.Do not leave the caregiver while the product is in use.
- 3.Do not use accessories not provided by the manufacturer.
- 4.Any load attached to the handle will affect the stability of the pet stroller.
- 5.Ensure that all the locking devices are assembled before using the pet stroller.
- 6.Pets must use restraints when using.
- 7.Do not use the pet stroller in rough areas, near stoves and other dangerous areas.
- 8.Avoid use or storage in damp, cold or high temperature environment and keep away from fire or strong heat source.
- 9.Do not use it to put dangerous animals which are aggressive and destructive.

**Maintenance and Care**

Please check and maintain the pet stroller frequently. The cloth cover cannot be dipped and washed. When the cloth cover is cleaned, please use a brush and other cleaning instruments to clean the dirt.

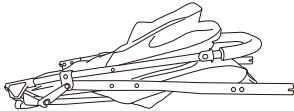
**Parts**

Stroller framex1

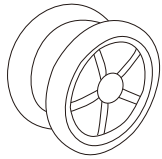

Front wheel x1



Rear wheel axel x1



Iron gasket x4

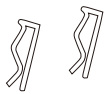

Bayonet lock x2



Rear wheel coverx2

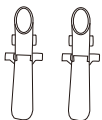

Rear wheel seat x2

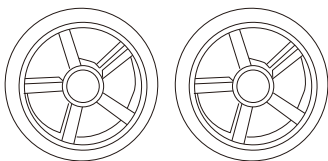

Rear wheel x2

## Unfolding and folding pet stroller

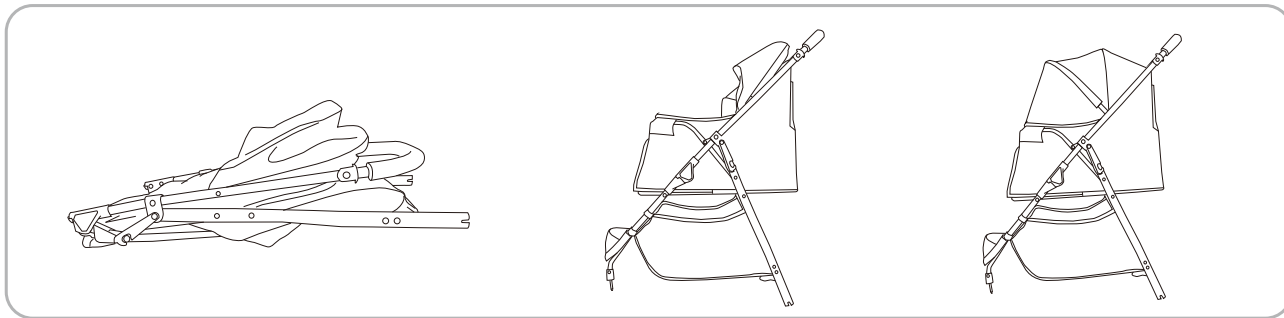

### 1. Unfolding frame

Take out the frame, hold the handle bar and lift it up. It is ok when you hear "click". After opening the frame, unfold the canopy and zip it up.

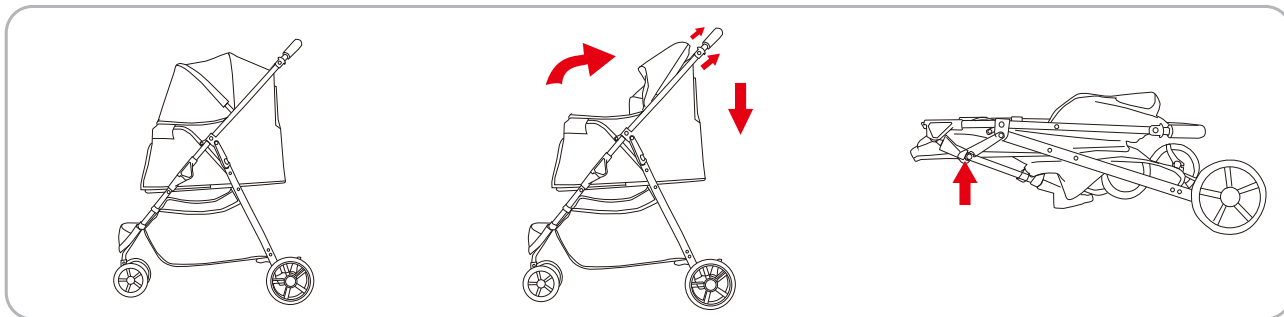

### 2. Folding frame

In the braking state, unzip the zipper and close the canopy first. And then, lift up the two sides of the folding keys, hold the handle to press down. The frame can be folded and hang the hook finally.

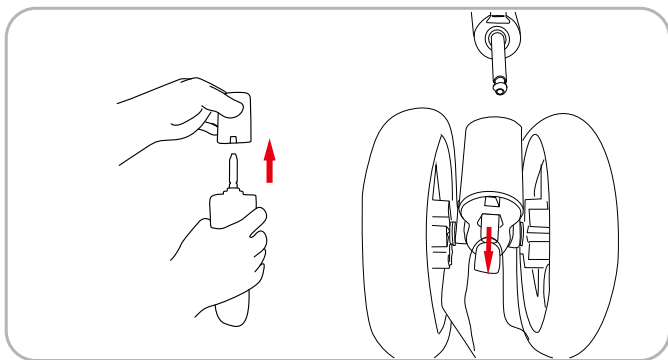

### 3. Usage of front wheels

Insert the front wheel into the hole of the front wheel seat and hear the "click". Hold the removal button and pull it down, the front wheel can be removed.

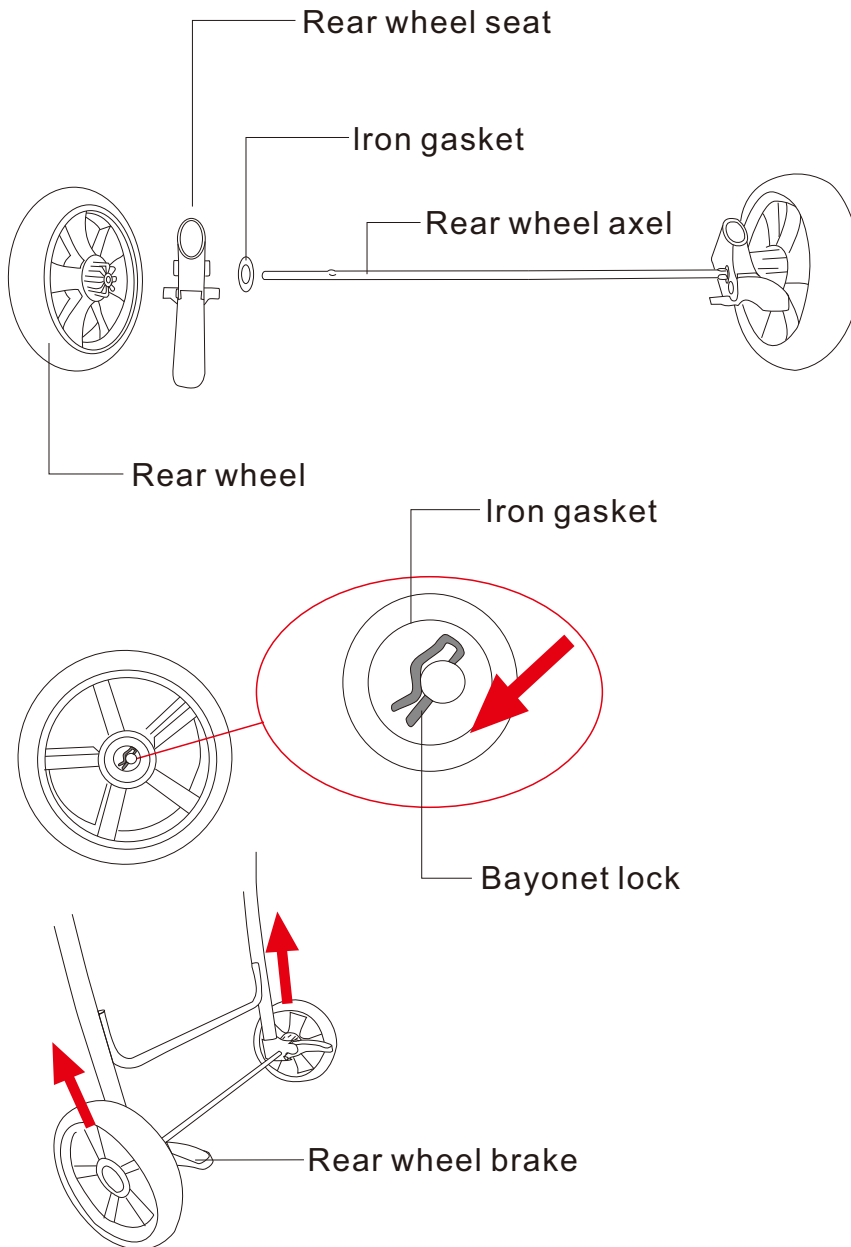

#### 4. Usage of rear wheels

Insert the iron gasket, rear wheel seat, and rear wheel into both sides of the rear wheel axle in turn, and add an iron gasket to each out axle hole of the rear wheel. Insert the bayonet lock, and finally cover the rear wheel cover to assemble the rear wheel set, put the rear wheel set on the rear foot tube, and hear the "click" sound. To remove it, press the buckle on the rear wheel seat and pull it out. Step down the brake rod on both sides of the rear wheel, the rear wheel is in the braking state, The rear wheel motion state can be restored by lifting the rear wheel brake rod upward.

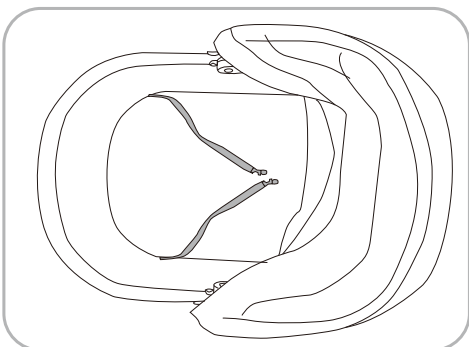

#### 5. For pet safety belts

**AVERTISSEMENT : Tenir à l'écart du feu**

- 1) Veuillez lire attentivement ces instructions avant d'utiliser l'appareil et conservez-les pour pouvoir les consulter ultérieurement. Si vous ne suivez pas ces instructions, la sécurité des animaux domestiques peut être compromise.
2. ne pas quitter la personne qui s'occupe de l'animal lorsque le produit est en cours d'utilisation.
3. n'utilisez pas d'accessoires non fournis par le fabricant.
4. toute charge attachée à la poignée affectera la stabilité de la poussette.
5. s'assurer que tous les dispositifs de verrouillage sont assemblés avant d'utiliser la poussette.
6. les animaux de compagnie doivent être attachés lorsqu'ils sont utilisés.
7. ne pas utiliser la poussette dans des zones accidentées, près de poêles ou d'autres zones dangereuses.
8. éviter d'utiliser ou de stocker la poussette dans un environnement humide, froid ou à haute température et la tenir éloignée du feu ou d'une forte source de chaleur.
9. ne pas l'utiliser pour placer des animaux dangereux, agressifs et destructeurs.

**Entretien et soins**

Veuillez vérifier et entretenir fréquemment la poussette pour animaux de compagnie. La housse en tissu ne peut pas être trempée ni lavée. Lorsque le revêtement en tissu est nettoyé, veuillez utiliser une brosse et d'autres instruments de nettoyage pour nettoyer la saleté.

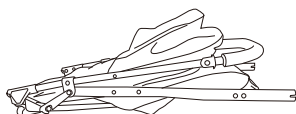
**Pièces détachées**

Cadre de poussette x1

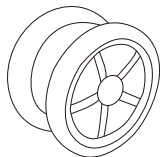

Roue avant x1



Axe de roue arrière x1



joint en fer x4



Serrure à baïonnette x2



Enjoliveur de roue arrière x2

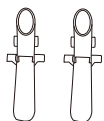

Siège de la roue arrière x2

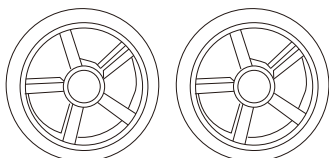

Roue arrière x2

## Pliage et dépliage de la poussette pour animaux de compagnie

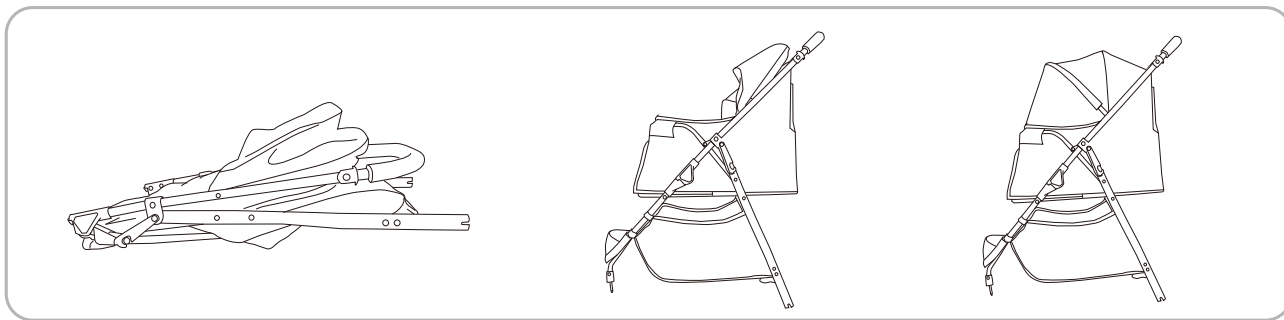

### 1. déplier le cadre

Sortez le cadre, tenez le guidon et soulevez-le. Après avoir ouvert le cadre, déployez la canopée et fermez la fermeture éclair.

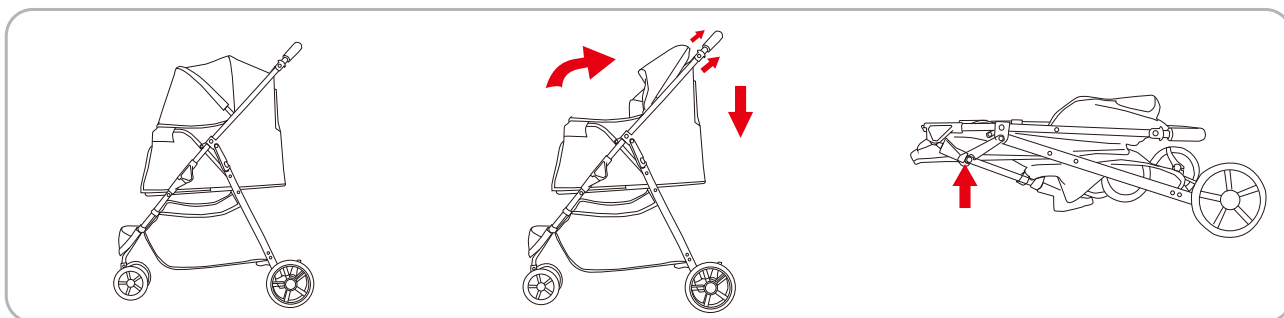

### 2. Pliage du cadre

En état de freinage, dézippez la fermeture à glissière et fermez d'abord la capote. Ensuite, soulevez les deux côtés des clés de pliage, tenez la poignée pour appuyer vers le bas. Le cadre peut être plié et accroché au crochet.

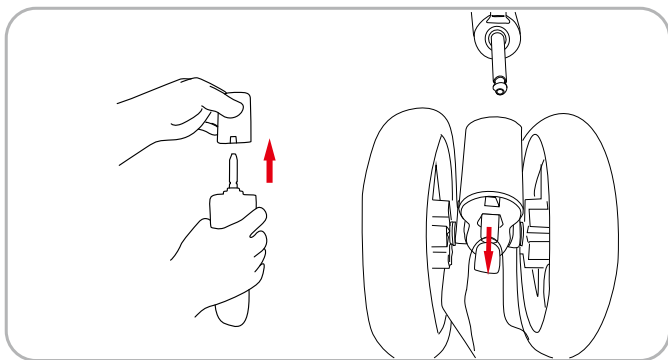

### 3. Utilisation des roues avant

Insérez la roue avant dans le trou du siège de la roue avant et entendez le « clic ». Maintenez le bouton de retrait et tirez-le vers le bas, la roue avant peut être retirée.

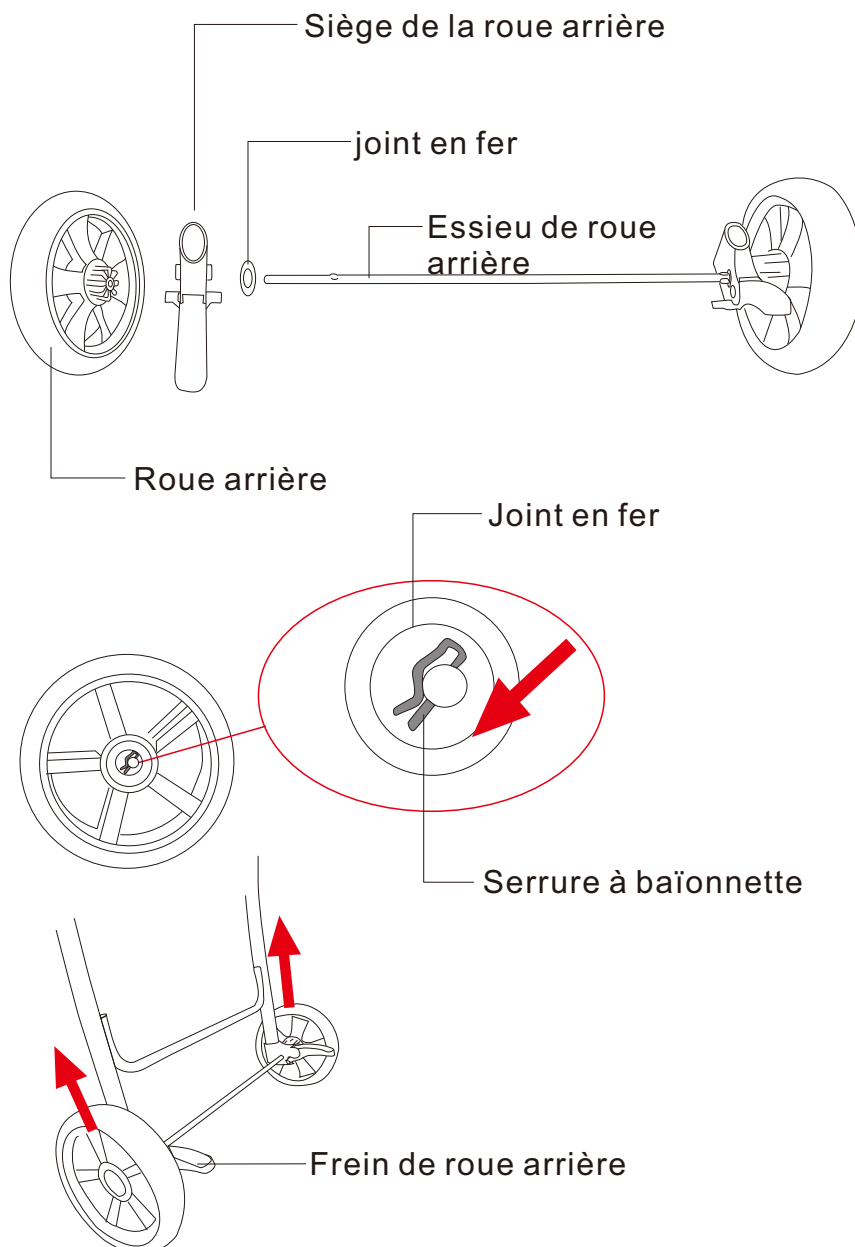

#### 4. Utilisation des roues arrière

Insérez le joint en fer, le siège de la roue arrière et la roue arrière dans les deux côtés de l'axe de la roue arrière à tour de rôle, et ajoutez un joint en fer dans chaque trou de l'axe de la roue arrière.

Insérer la serrure à baïonnette, et enfin couvrir le couvercle de la roue arrière. Pour assembler le jeu de roues arrière, placer le jeu de roues arrière sur le tube du pied arrière, et entendre le « clic ».

Pour le retirer, appuyez sur la boucle du siège de la roue arrière et tirez-la.

Le mouvement de la roue arrière peut être rétabli en soulevant la tige de frein de la roue arrière vers le haut.

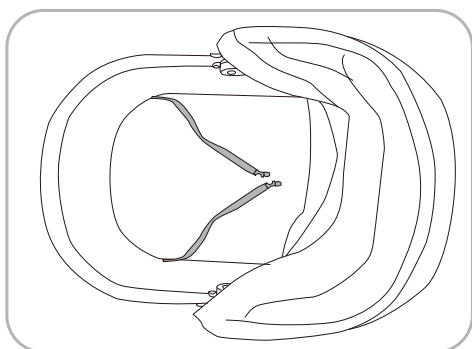

5. pour les ceintures de sécurité des animaux de compagnie

**ADVERTENCIA: Mantener alejado del fuego**

1. Lea atentamente estas instrucciones antes de utilizar el aparato y consérvelas para futuras consultas. Si no sigue estas instrucciones, la seguridad de las mascotas puede verse afectada.
2. No deje al cuidador mientras el producto esté en uso.
3. No utilice accesorios no suministrados por el fabricante.
4. Cualquier carga fijada al asa afectará a la estabilidad de la silla de paseo para mascotas.
5. Asegúrese de que todos los dispositivos de bloqueo están montados antes de utilizar la silla de paseo para mascotas.
6. Las mascotas deben ir sujetas cuando se utilicen.
7. No utilice la silla de paseo para mascotas en zonas abruptas, cerca de estufas y otras zonas peligrosas.
8. Evite utilizarlo o guardarlo en ambientes húmedos, fríos o con altas temperaturas y manténgalo alejado del fuego o de fuentes de calor fuertes.
9. No lo utilice para meter animales peligrosos que sean agresivos y destructivos.

**Mantenimiento y cuidado**

Compruebe y mantenga la silla de paseo con frecuencia. La funda de tela no se puede sumergir ni lavar. Cuando limpie la funda de tela, utilice un cepillo y otros instrumentos de limpieza para eliminar la suciedad.

**Piezas**

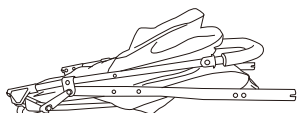

Armazón del cochecito x1

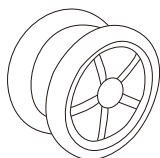

Rueda delantera x1

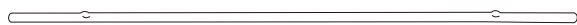

Eje de rueda trasera x1



Junta de hierro x4



Cierre de bayoneta x2



Cubre rueda trasero x2

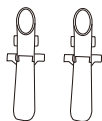

Asiento rueda trasera x2

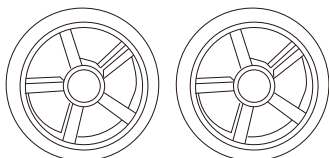

Rueda trasera x2



## Silla de paseo para mascotas desplegable y plegable

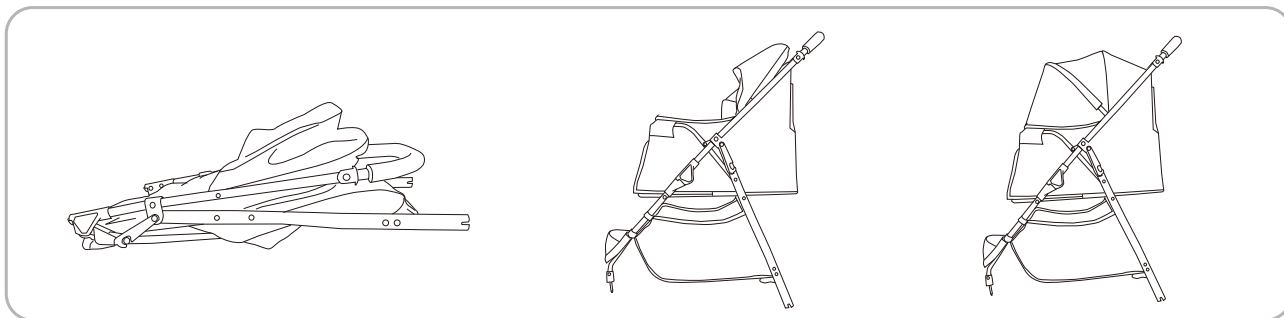

### 1. Despliegue del bastidor

Saque el armazón, sujete el manillar y levántelo. Una vez abierto el armazón, despliegue la capota y cierre la cremallera.

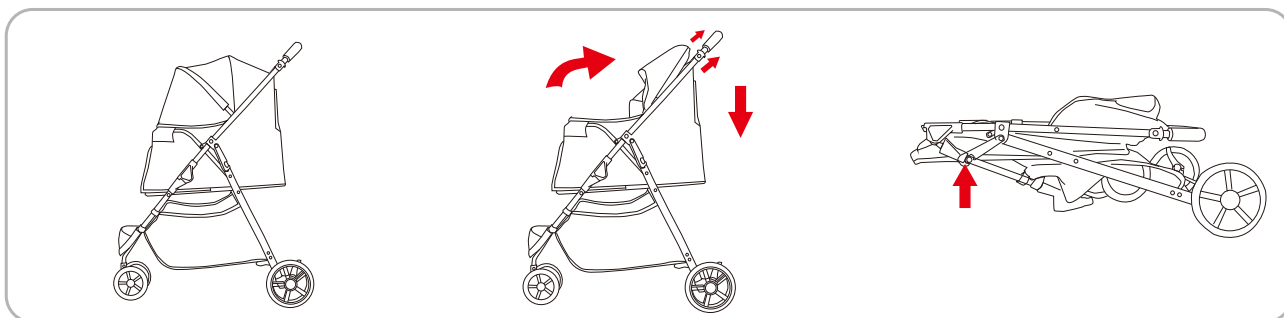

### 2. Bastidor plegable

En estado de frenado, abra primero la cremallera y cierre la capota. A continuación, levante los dos lados de las llaves de plegado, sujete el asa para presionar hacia abajo. El marco se puede plegar y colgar el gancho finalmente.

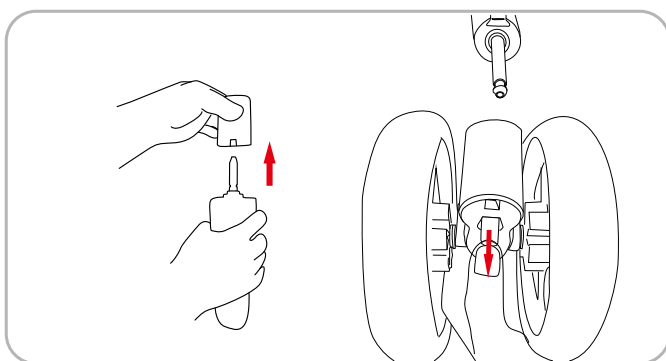

### 3. Uso de las ruedas delanteras

Inserte la rueda delantera en el orificio del asiento de la rueda delantera y escuche el «clic». Sujete el botón de extracción y tire de él hacia abajo, la rueda delantera se puede extraer.

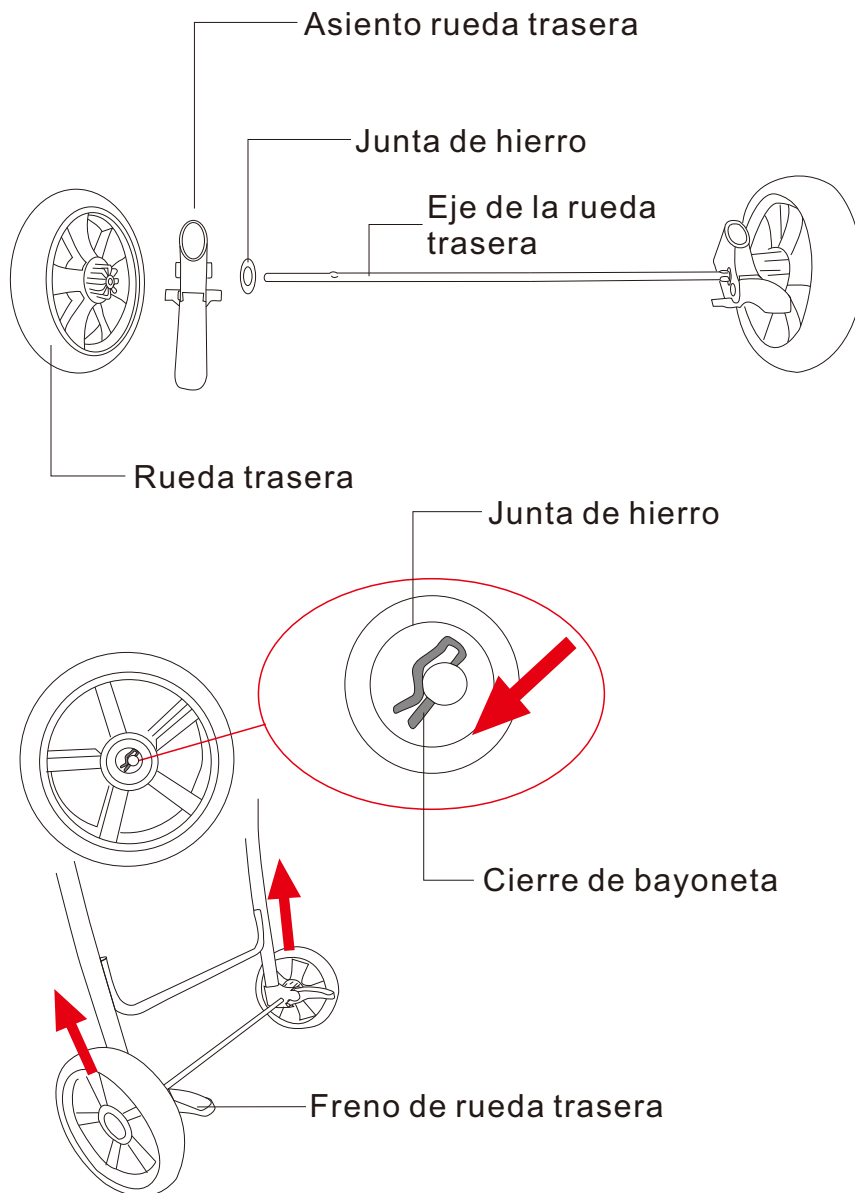

#### 4. Uso de las ruedas traseras

Inserte sucesivamente la junta de hierro, el asiento de la rueda trasera y la rueda trasera en ambos lados del eje de la rueda trasera, y añada una junta de hierro en cada orificio del eje exterior de la rueda trasera.

Inserte el cierre de bayoneta y, por último, cubra la cubierta de la rueda trasera para montar el juego de ruedas traseras, coloque el juego de ruedas traseras en el tubo del pie trasero y escuche el sonido «clic».

Para desmontarlo, presione la hebilla del asiento de la rueda trasera y tire de ella. Baje la varilla de freno en ambos lados de la rueda trasera, la rueda trasera está en estado de frenado, El estado de movimiento de la rueda trasera se puede restaurar levantando la varilla de freno de la rueda trasera hacia arriba.

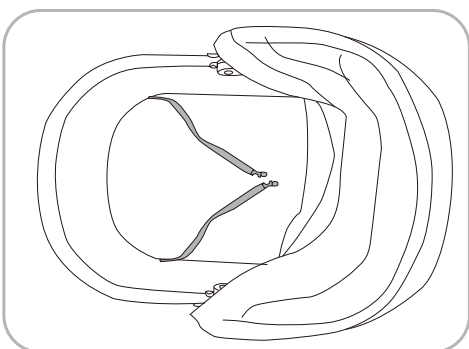

#### 5. Para cinturones de seguridad para mascotas

**AVISO:** Manter afastado do fogo

1. leia atentamente estas instruções antes de as utilizar e guarde-as corretamente para referência futura. Se não seguir estas instruções, a segurança dos animais de estimação pode ser afetada.
- 2 - Não deixe o cuidador enquanto o produto estiver a ser utilizado.
3. não utilizar acessórios não fornecidos pelo fabricante.
4. qualquer carga colocada na pega afectará a estabilidade do carrinho de passeio para animais de estimação.
5. certificar-se de que todos os dispositivos de bloqueio estão montados antes de utilizar o carrinho de bebé
6. os animais de estimação devem usar dispositivos de retenção durante a utilização.
7. não utilize o carrinho de bebé em áreas irregulares, perto de fogões e outras áreas perigosas.
8. evitar a utilização ou armazenamento em ambientes húmidos, frios ou com temperaturas elevadas e manter afastado do fogo ou de fontes de calor fortes.
9. não o utilize para colocar animais perigosos que sejam agressivos e destrutivos.

### Manutenção e cuidados

Verificar e manter o carrinho de bebé com frequência. A cobertura de tecido não pode ser mergulhada e lavada. Quando a cobertura de tecido for limpa, utilize uma escova e outros instrumentos de limpeza para limpar a sujidade.

### Peças

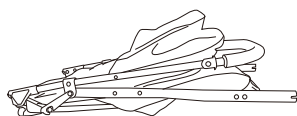

Estrutura do carrinho de bebé x1

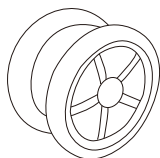

Roda dianteira x1



Eixo da roda traseira x1



Junta de ferro x4



Fecho de baioneta x2



Cobertura da roda traseira x2

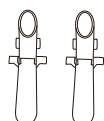

Assento da roda traseira x2

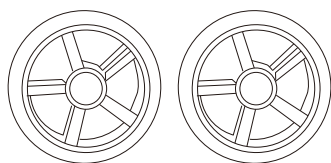

Roda traseira x2

## Carrinho de passeio desdobrável e dobrável para animais de estimação

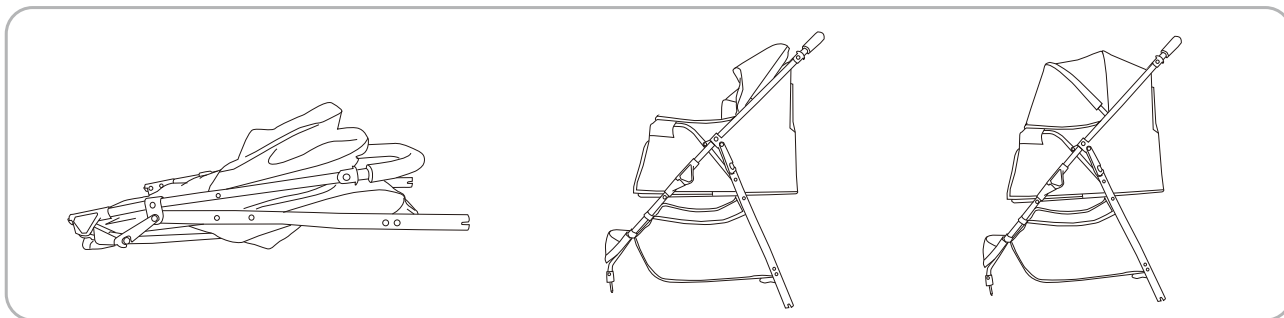

### 1. desdobrar o quadro

Retire a armação, segure a barra de direção e levante-a. Está tudo bem quando ouvir um “clique”. Depois de abrir o quadro, desdobre a capota e feche o fecho.

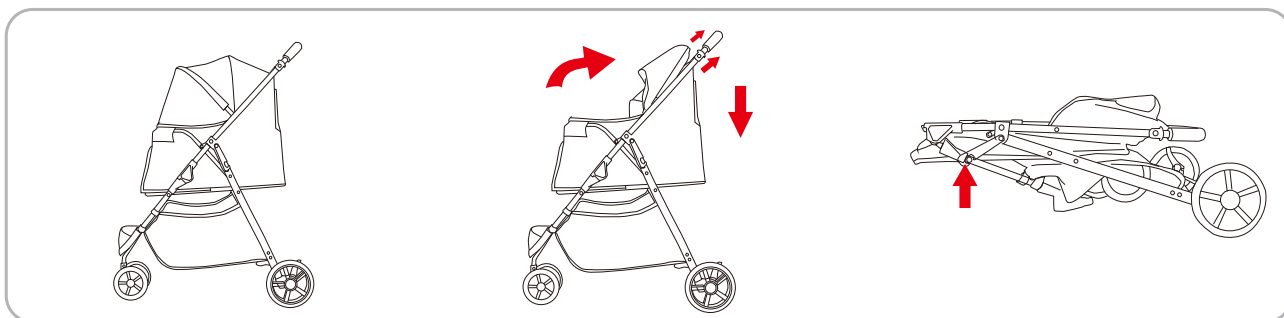

### 2. Armação dobrável

No estado de travagem, abrir o fecho de correr e fechar primeiro a capota. Em seguida, levante os dois lados das chaves de dobragem, segure a pega para pressionar para baixo. A estrutura pode ser dobrada e finalmente pendurada no gancho.

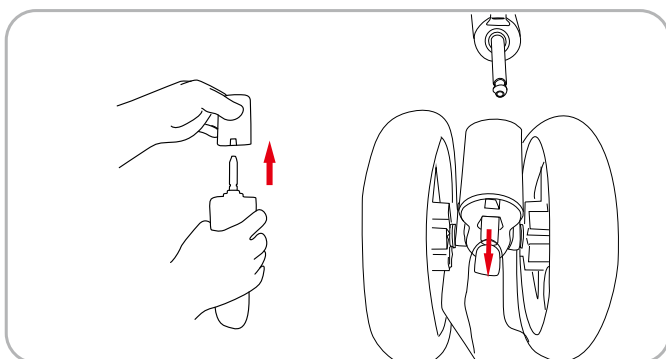

### 3. Utilização das rodas dianteiras

Insira a roda dianteira no orifício do assento da roda dianteira e ouça o “clique”. Segure o botão de remoção e puxe-o para baixo, a roda dianteira pode ser removida.

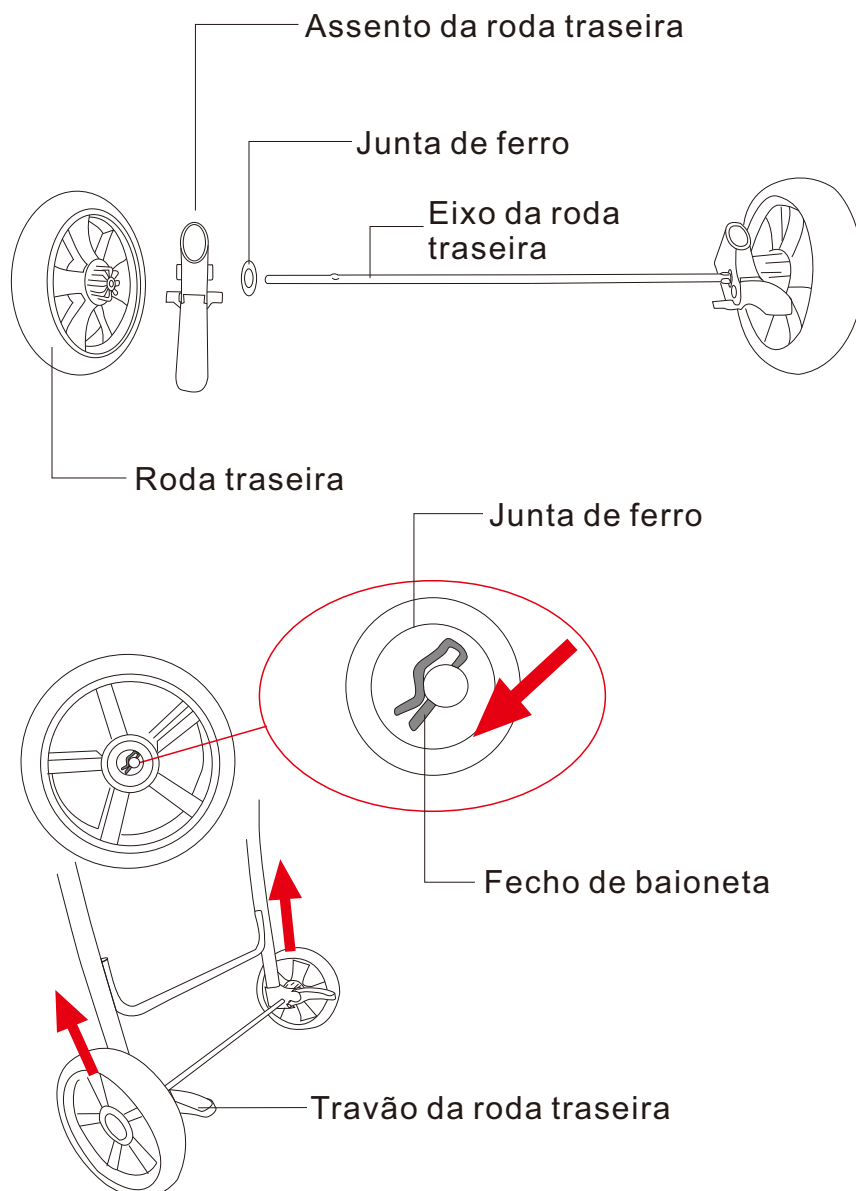

#### 4. Utilização das rodas traseiras

Inserir a junta de ferro, o assento da roda traseira e a roda traseira em ambos os lados do eixo da roda traseira e adicionar uma junta de ferro a cada orifício do eixo exterior da roda traseira.

Inserir o fecho de baioneta e, por fim, tapar a tampa da roda traseira. Para montar o conjunto da roda traseira, colocar o conjunto da roda traseira no tubo do pé traseiro e ouvir o som de “clique”.

Para o retirar, prima a fivela do assento da roda traseira e puxe-o para fora.

Descer a barra de travão em ambos os lados da roda traseira, a roda traseira está no estado de travagem. O estado de movimento da roda traseira pode ser restaurado levantando a barra de travão da roda traseira para cima.

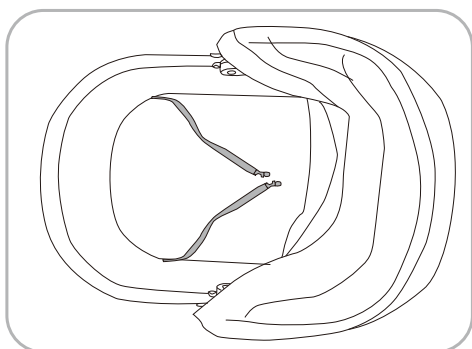

5. para cintos de segurança para animais de estimação

**WARNUNG: Von Feuer fernhalten**

1. Bitte lesen Sie diese Anweisung vor der Verwendung sorgfältig durch und bewahren Sie sie zum späteren Nachschlagen auf. Wenn Sie diese Anweisung nicht befolgen, kann die Sicherheit von Haustieren beeinträchtigt werden.
2. Während der Verwendung des Produkts darf sich die Betreuungsperson nicht entfernen.
3. Verwenden Sie kein Zubehör, das nicht vom Hersteller bereitgestellt wird.
4. Jede an der Lenkstange befestigte Last beeinträchtigt die Stabilität des Hundebuggys.
5. Stellen Sie sicher, dass alle Verriegelungsvorrichtungen vor der Verwendung des Hundebuggys montiert sind.
6. Haustiere müssen bei der Verwendung angeschnallt sein.
7. Verwenden Sie den Hundebuggy nicht in rauen Gegenden, in der Nähe von Öfen oder anderen gefährlichen Bereichen.
8. Verwenden oder lagern Sie ihn nicht in feuchten, kalten oder heißen Umgebungen und halten Sie ihn von Feuer oder starken Wärmequellen fern.
9. Verwenden Sie ihn nicht für gefährliche Tiere, die aggressiv und zerstörerisch sind.

**Wartung und Pflege**

Bitte überprüfen und warten Sie den Hundebuggy regelmäßig. Das Verdeck kann nicht getaucht und gewaschen werden. Wenn Sie das Verdeck reinigen, verwenden Sie bitte eine Bürste und andere Reinigungsmittel, um den Schmutz zu entfernen.

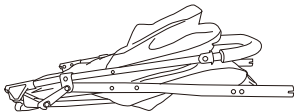
**Teile**

Kinderwagen framex1

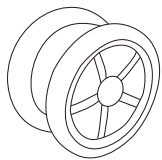

Vorderrad x1

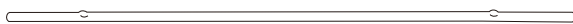

Hinterradachse x1



Ironendichtung x4

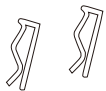

Bajonettverschluss x2



Hinterradabdeckungx2

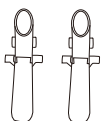

Hinterradsitz x2

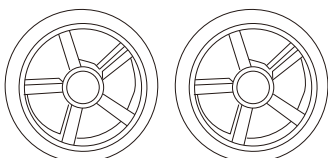

Hinterrad x2

## Aufklappbarer und zusammenklappbarer Hundebuggy

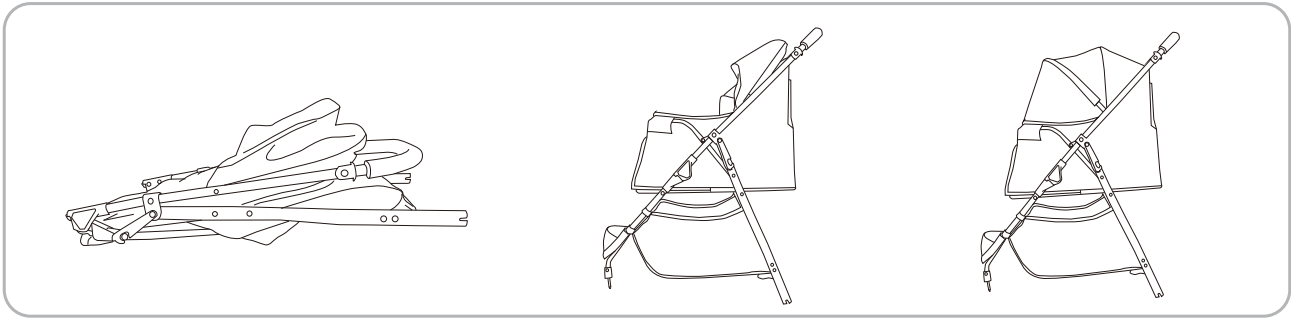

### 1. den Rahmen ausklappen

Nehmen Sie den Rahmen heraus, halten Sie ihn am Griff fest und heben Sie ihn an. Nachdem Sie den Rahmen geöffnet haben, klappen Sie das Verdeck aus und schließen Sie den Reißverschluss.

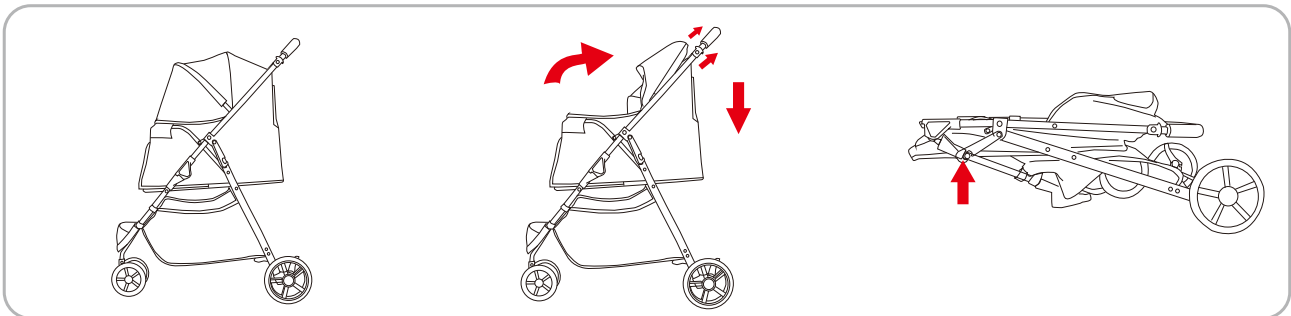

### 2. Klappbarer Rahmen

Öffnen Sie im gebremsten Zustand zuerst den Reißverschluss und schließen Sie das Verdeck. Dann heben Sie die beiden Seiten der Falltasten an, halten Sie den Griff fest und drücken Sie ihn nach unten. Das Gestell kann gefaltet werden und der Haken kann aufgehängt werden.

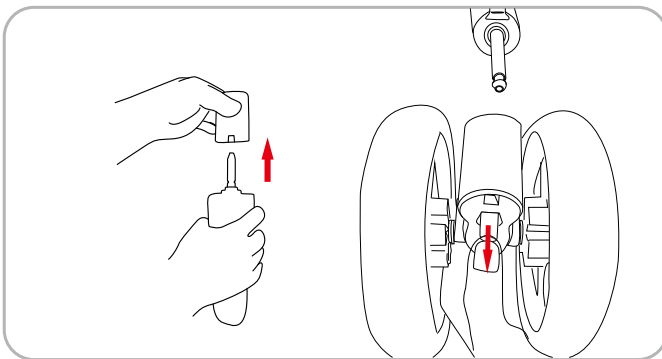

### 3. Verwendung der Vorderräder

Stecken Sie das Vorderrad in das Loch des Vorderradsitzes und hören Sie das "Klicken". Halten Sie den Entnahmeknopf und ziehen Sie ihn nach unten, das Vorderrad kann entfernt werden.

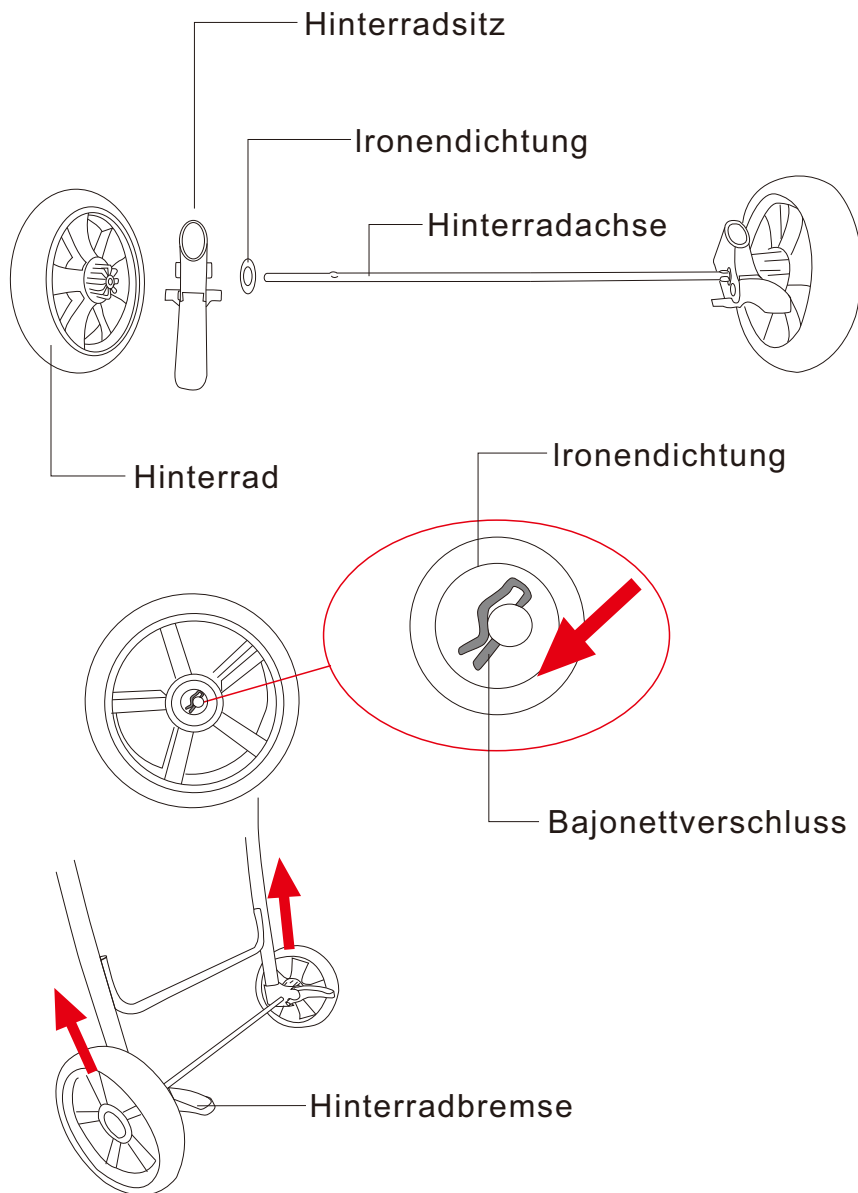

#### 4. Verwendung der Hinterräder

Setzen Sie die Eisendichtung, den Hinterradsitz und das Hinterrad nacheinander in beide Seiten der Hinterradachse ein und fügen Sie eine Eisendichtung in jedes Achsloch des Hinterrads ein.

Setzen Sie den Bajonettverschluss ein und decken Sie schließlich die Hinterradabdeckung ab, um den Hinterradsatz zu montieren, setzen Sie den Hinterradsatz auf das hintere Fußrohr, und hören Sie das "Klick"-Geräusch. Zum Abnehmen drücken Sie auf die Schnalle am Hinterradsitz und ziehen Sie ihn heraus.

Ziehen Sie die Bremsstange auf beiden Seiten des Hinterrads nach unten. Das Hinterrad ist gebremst, und der Bewegungszustand des Hinterrads kann durch Anheben der Bremsstange wiederhergestellt werden.

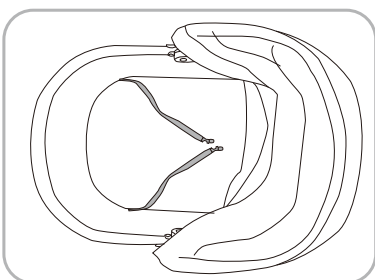

#### 5. für Sicherheitsgurte für Haustiere



**AVVERTENZA: Tenere lontano dal fuoco**

1. Leggere attentamente le presenti istruzioni prima dell'uso e conservarle per future consultazioni. Se non si seguono queste istruzioni, la sicurezza degli animali domestici potrebbe essere compromessa.

2. Non abbandonare il personale di assistenza mentre il prodotto è in uso.

3. Non utilizzare accessori non forniti dal produttore.

4. Qualsiasi carico attaccato alla maniglia influisce sulla stabilità del passeggino.

5. Assicurarsi che tutti i dispositivi di bloccaggio siano montati prima di utilizzare il passeggino.

6. Gli animali domestici devono essere trattiene durante l'uso.

7. Non utilizzare il passeggino in zone impervie, vicino a stufe o altre aree pericolose.

8. Evitare l'uso o lo stoccaggio in ambienti umidi, freddi o ad alta temperatura e tenerlo lontano dal fuoco o da forti fonti di calore.

9. Non utilizzarlo per mettere animali pericolosi, aggressivi e distruttivi.

**Manutenzione e cura**

Controllare e mantenere frequentemente il passeggino per animali domestici. Il rivestimento in tessuto non può essere immerso e lavato. Quando si pulisce il rivestimento in tessuto, utilizzare una spazzola o altri strumenti di pulizia per eliminare lo sporco.

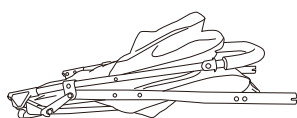
**Parti di ricambio**

Telaio del passeggino x1

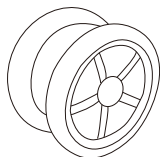

Ruota anteriore x1



Asse della ruota posteriore x1



Guarnizione in ferro x4



Serratura a baionetta x2



Copriruota posteriore x2

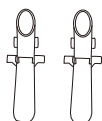

Sedile ruota posteriore x2

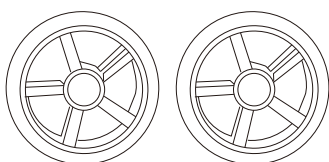

Ruota posteriore x2

## Passeggino per animali da compagnia pieghevole e ripiegabile

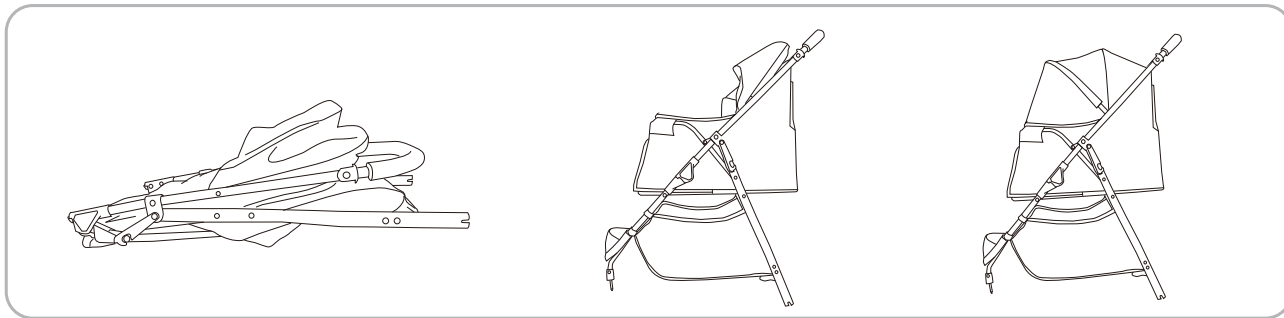

### 1. Svolgimento del telaio

Estrarre il telaio, tenere la barra della maniglia e sollevarlo. Dopo aver aperto il telaio, aprire la capottina e chiudere la zip.

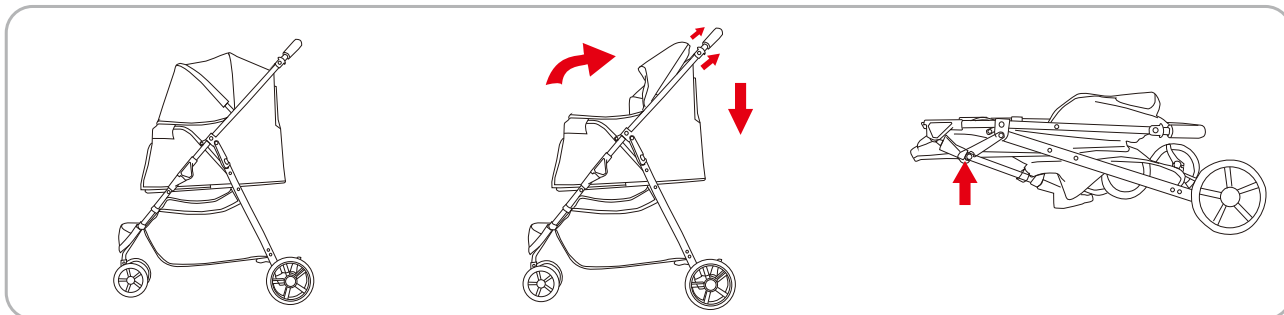

### 2. Telaio pieghevole

In fase di frenata, aprire la cerniera e chiudere la cappottina. Quindi, sollevare i due lati delle chiavi pieghevoli e tenere la maniglia per premere verso il basso. Il telaio può essere piegato e appeso al gancio.

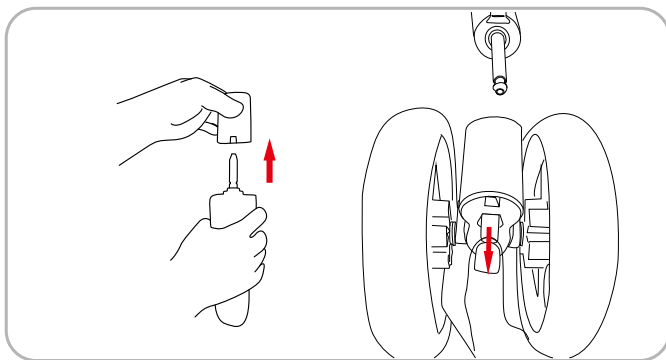

### 3. Utilizzo delle ruote anteriori

Inserire la ruota anteriore nel foro della sede della ruota anteriore e sentire il "clic". Tenere il pulsante di rimozione e tirarlo verso il basso, la ruota anteriore può essere rimossa.

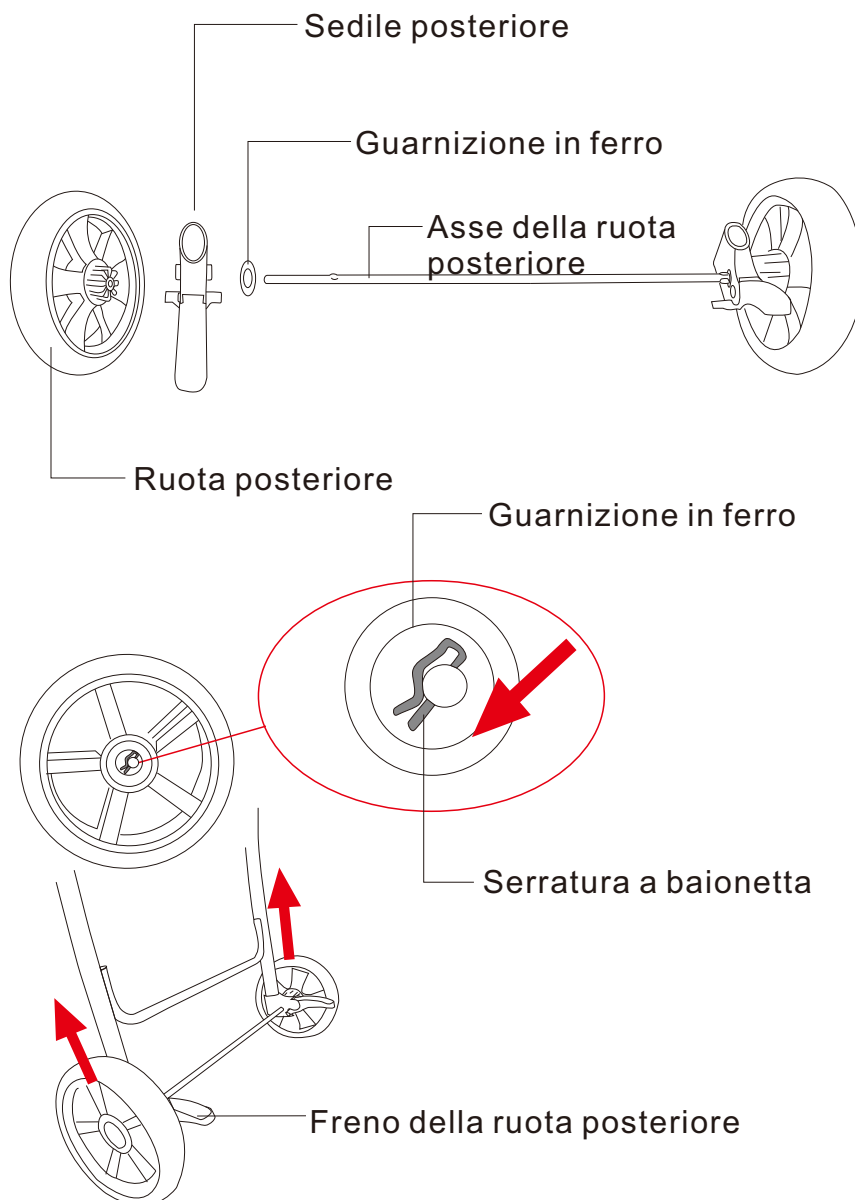

#### 4. Uso delle ruote posteriori

Inserire la guarnizione in ferro, la sede della ruota posteriore e la ruota posteriore in entrambi i lati dell'asse della ruota posteriore e aggiungere una guarnizione in ferro a ciascun foro dell'asse della ruota posteriore.

Inserire la chiusura a baionetta e infine coprire il coperchio della ruota posteriore per assemblare il set di ruote posteriori, mettere il set di ruote posteriori sul tubo del piede posteriore e sentire il suono "click".

Per rimuoverlo, premere la fibbia sulla sede della ruota posteriore ed estrarlo.

Abbassare l'asta del freno su entrambi i lati della ruota posteriore, la ruota posteriore è in stato di frenata, lo stato di movimento della ruota posteriore può essere ripristinato sollevando l'asta del freno della ruota posteriore verso l'alto.

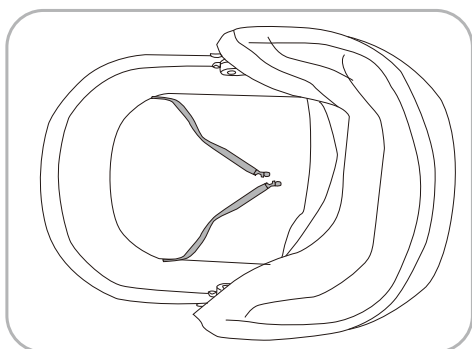

#### 5. Per le cinture di sicurezza per animali domestici

If you have any questions, please contact our customer care center, Our contact details are below:

**US**

 001-877-644-9366

 customerservice@aosom.com

Imported by Aosom LLC  
27150 SW Kinsman Rd Wilsonville, OR 97070 USA  
MADE IN CHINA

If you have any questions, please contact our customer care center, Our contact details are below:

**CA**

 416-792-6088

 customerservice@aosom.ca

Imported by Aosom Canada Inc.  
7270 Woodbine Avenue, Unit 307, Markham,  
Ontario Canada L3R 4B9  
MADE IN CHINA

Si vous avez la moindre question, veuillez contacter notre centre d'assistance à la clientèle, Nos coordonnées sont les suivantes:

 416-792-6088

 customerservice@aosom.ca

Importé par Aosom Canada Inc.  
7270 Woodbine Avenue, unité 307,  
Markham, Ontario Canada L3R 4B9  
FABRIQUÉ EN CHINE

If you have any questions, please contact our customer care center, Our contact details are below:

**UK**

 0044-800-240-4004

 enquiries@mhstar.co.uk

IMPORTER ADDRESS:  
MH STAR UK LTD  
Unit 27, Perivale Park,  
Horsenden lane South  
Perivale, UB6 7RH  
MADE IN CHINA

Si vous avez la moindre question, veuillez contacter notre centre d'assistance à la clientèle, Nos coordonnées sont les suivantes:

**FR**

 0033-1-84166106

 aosom@mhfrance.fr

Importé par/Fabricant/REP:  
MH FRANCE  
2 Rue Maurice Hartmann  
92130 Issy Les Moulineaux  
France  
FABRIQUÉ EN CHINE

Wenn Sie Fragen haben, wenden Sie sich bitte an unser Kundendienstzentrum, Unsere Kontaktdaten stehen unten:

**DE**

 0049-0(40)-88307530

 service@aosom.de

ADRESSE DES IMPORTEURE/Hersteller/REP:  
MH Handel GmbH  
Wendenstraße 309  
D-20537 Hamburg  
Germany  
IN CHINA HERGESTELLT

In caso di dubbio, si prega di contattare il nostro centro assistenza clienti, I nostri dettagli di contatto sono di seguito:

**IT**

 0039-0249471447

 clienti@aosom.it

IMPORTATO DA/Produttore/REP:  
AOSOM Italy srl  
Centro Direzionale Milanofiori  
Strada 1 Palazzo F1  
20057 Assago (MI)  
P.I.: 08567220960  
FATTO IN CINA

Si tiene alguna pregunta, comuníquese con nuestro Centro de Atención al Cliente, Nuestros datos de contacto son los siguientes:

**ES**

 0034-931294512

 atencioncliente@aosom.es

IMPORTADOR/Fabricante/REP:  
SPANISH AOSOM, S.L.  
C/ROC GROS, N°15.08550, ELS HOSTALETS DE  
BALENYÀ, SPAIN.  
B66295775  
HECHO EN CHINA

Se tiver alguma dúvida, por favor contacte o nosso Centro de Atendimento ao Cliente, Os nossos dados de contacto são os seguintes:

**PT**

 0034-931294512

 info@aosom.pt.

IMPORTADOR/Fabricante/REP:  
SPANISH AOSOM, S.L.  
C.ROC GROS N.15, 08550. ELS HOSTALETS DE  
BALENYÀ  
FEITO NA CHINA



**FR**

**DONNEZ  
OU  
RECYCLEZ**



ASSOCIATION

OU



LIVRAISON

OU



DÉCHÈTERIE

Adresses sur [quefairedemesdechets.fr](http://quefairedemesdechets.fr)