

EN_NOTES:

- At least twice a year, lubricate the top and bottom of the drawer slides.
- A void opening more than one loaded drawer simultaneously.
- Maximum load : 310 lbs.

FR_NOTES :

- Au moins deux fois par an, lubrifier le haut et le bas des glissières du tiroir.
- Ne pas ouvrir plus d'un tiroir chargé simultanément.
- Charge maximale : 310 lbs.

ES_NOTAS:

- Al menos dos veces al año, lubrique la parte superior e inferior de las guías de los cajones.
- A nule la apertura simultánea de más de un cajón cargado.
- Carga máxima : 310 lbs.

PT_NOTAS:

- Pelo menos duas vezes por ano, lubrificar a parte superior e inferior das corrediças da gaveta.
- Não abrir simultaneamente mais do que uma gaveta carregada.
- Carga máxima: 310 lbs.

DE_HINWEISE:

- Schmieren Sie mindestens zweimal pro Jahr die Ober- und Unterseite der Schubladenführungen.
- Öffnen Sie nicht mehr als eine beladene Schublade gleichzeitig.
- Maximale Belastung: 310 lbs.

IT_NOTE:

- Almeno due volte all'anno, lubrificare la parte superiore e inferiore delle guide dei cassetti.
- Non aprire contemporaneamente più di un cassetto carico.
- Carico massimo: 310 libbre.

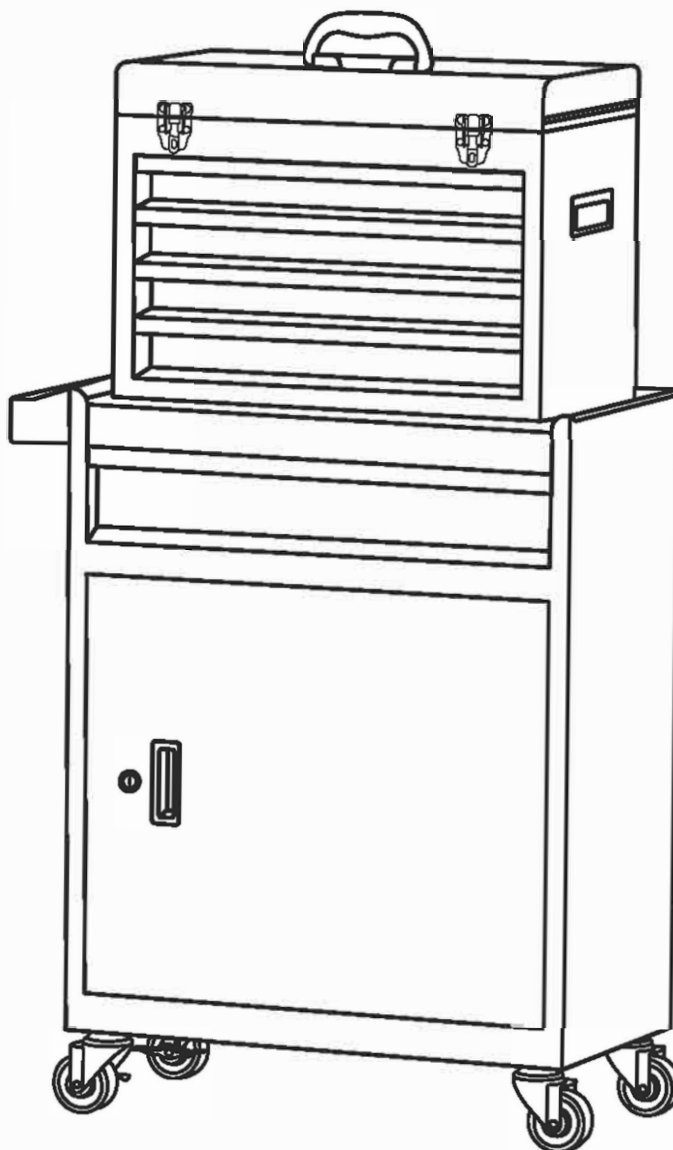

EN_IMPORTANT, RETAIN FOR FUTURE REFERENCE: READ CAREFULLY.

FR_IMPORTANT: A LIRE ATTENTIVEMENT ET À CONSERVER POUR CONSULTATION ULTÉRIEURE.

ES_IMPORTANTE, LEA Y GUARDE PARA FUTURAS REFERENCIAS.

PT_IMPORTANTE, RETER PARA REFERÊNCIA FUTURA: LEIA ATENTAMENTE.

DE_WICHTIG! SORGFÄLTIG LESEN UND FÜR SPÄTER NACHSCHLAGEN AUFBEWAHREN.

IT_IMPORTANTE! CONSERVARE IL PRESENTE MANUALE PER FUTURO RIFERIMENTO E LEGGERLO ATTENTAMENTE.

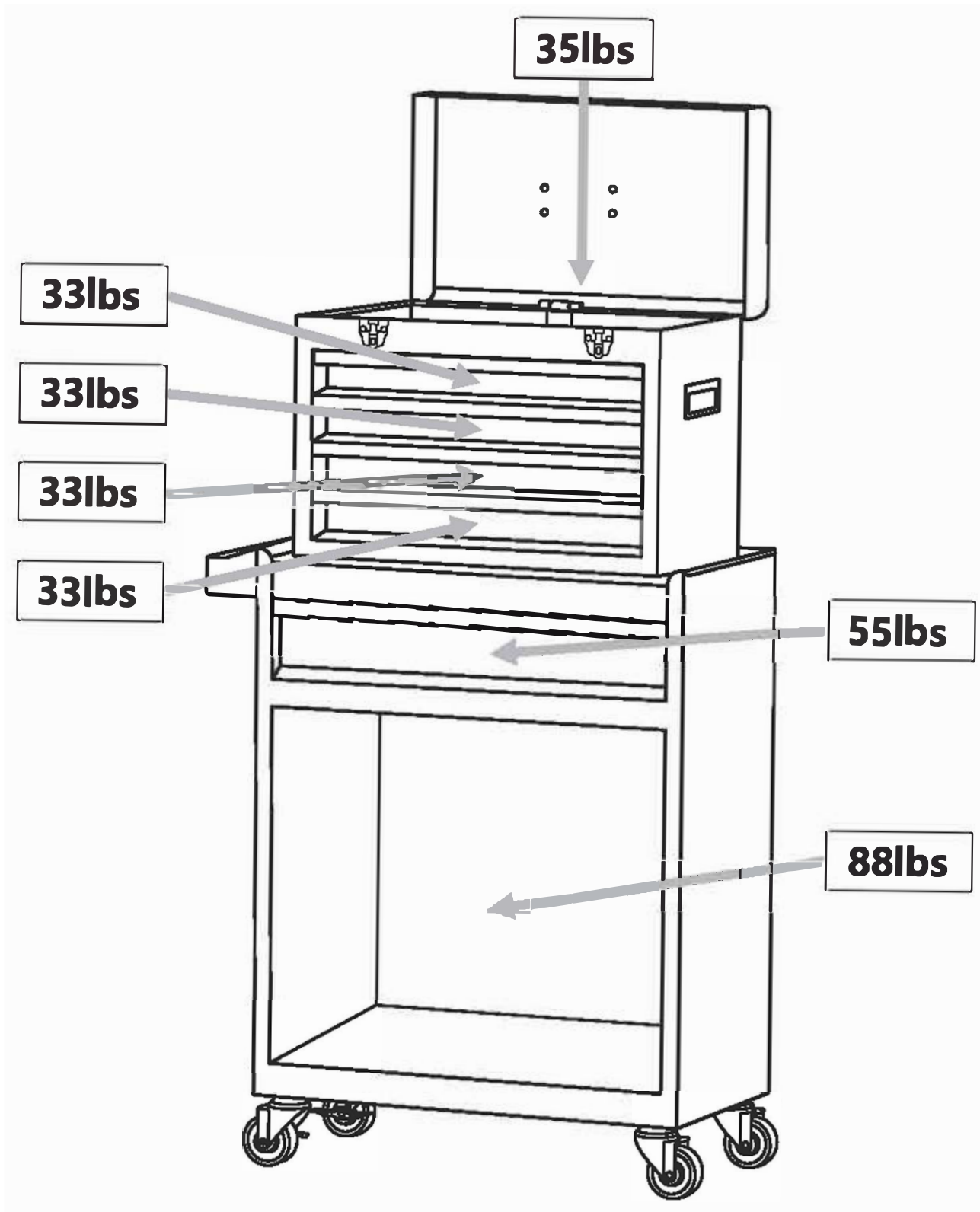

① x 1

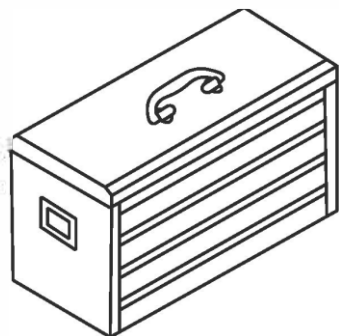

② x 2



③ x 2

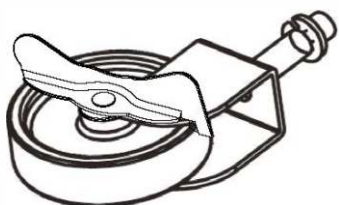

④ x 4

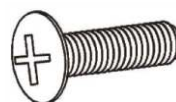

⑤ x 1



⑥ x 4

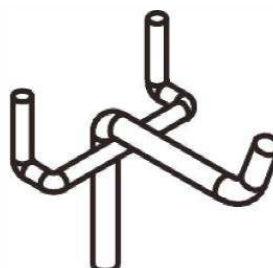

⑦ x 1



⑧ x 1



Removal of Assembly

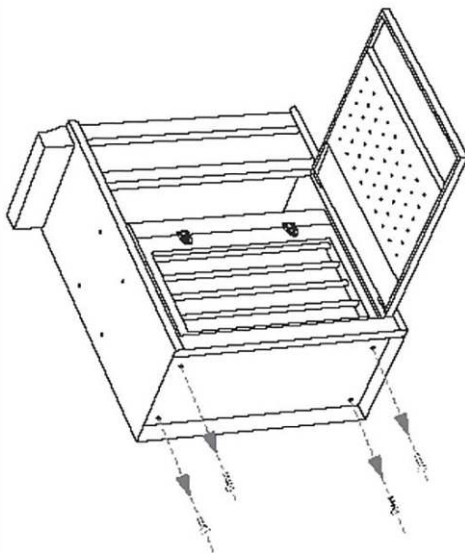

EN Place the cabinet on its back on a flat surface. Using a screwdriver, remove the four bottom screws. Remember to save these screws for later use.

FR Placez l'armoire sur le dos sur une surface plane. À l'aide d'un tournevis, retirez les quatre vis du fond. N'oubliez pas de conserver ces vis pour une utilisation ultérieure.

ES Coloque el armario boca arriba sobre una superficie plana. Con un destornillador, retire los cuatro tornillos inferiores. Recuerde guardar estos tornillos para su uso posterior.

PT Colocar o armário de costas sobre uma superfície plana. Com uma chave de fendas, retire os quatro parafusos inferiores. Não se esqueça de guardar estes parafusos para utilização posterior.

DE Legen Sie den Schrank auf einer ebenen Fläche auf den Rücken. Entfernen Sie die vier unteren Schrauben mit einem Schraubendreher. Bewahren Sie diese Schrauben für eine spätere Verwendung auf.

IT Posizionare il mobile sul retro su una superficie piana. Con un cacciavite, rimuovere le quattro viti inferiori. Ricordarsi di conservare queste viti per un uso successivo.

Take out top part

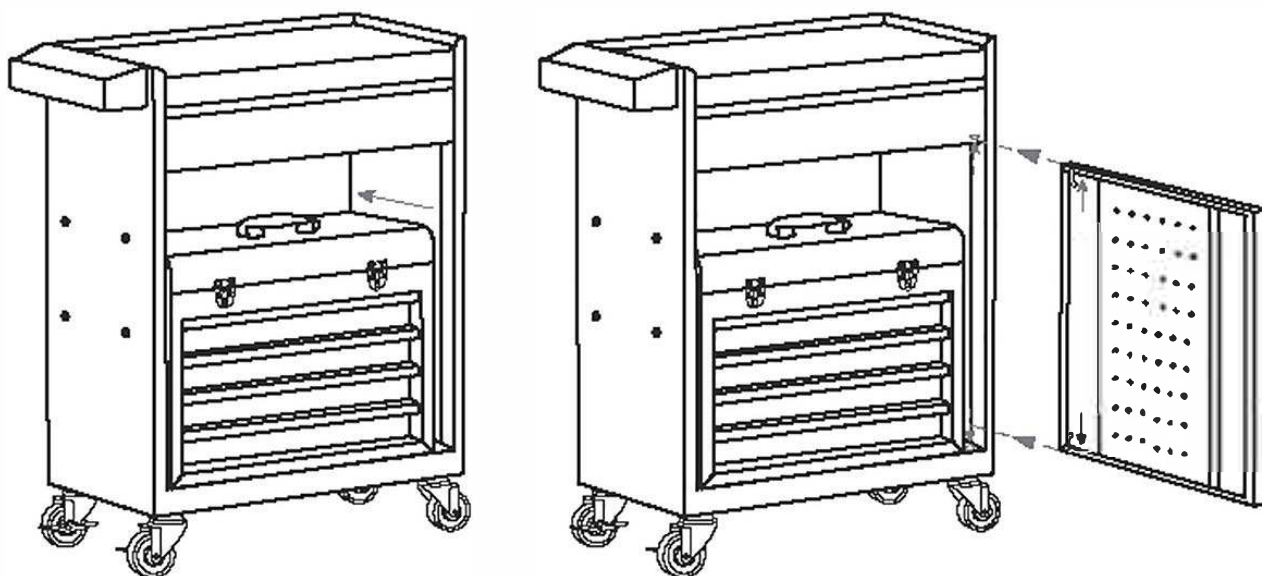

EN Pull one of the two triggers located at the end to remove the door

FR Tirez sur l'une des deux gâchettes situées à l'extrémité pour retirer la porte.

ES Tire de uno de los dos gatillos situados en el extremo para extraer la puerta

PT Puxar um dos dois gatilhos situados na extremidade para retirar a porta

DE Ziehen Sie einen der beiden Auslöser am Ende, um die Tür zu entfernen.

IT Tirare uno dei due grilletti situati all'estremità per rimuovere lo sportello.

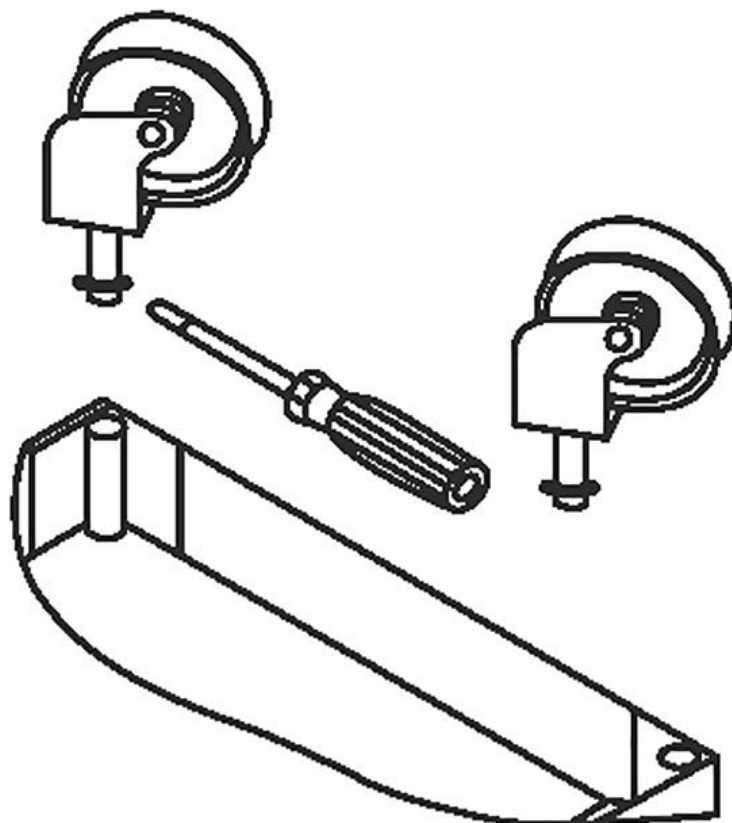

EN Insert the wheels into the cabinet 's bottom holes. If the wheel does not stay in position, loosen the ring around the axle by spreading it with a screwdriver. If the wheel is difficult to enter the hole, tighten the ring around the axis with a clamp. These adjustments should be minimal (no more than 1mm).

FR Insérez les roues dans les trous du fond de l'armoire. Si la roue ne reste pas en place, desserrez l'anneau autour de l'axe en l'écartant à l'aide d'un tournevis. Si la roue a du mal à entrer dans le trou, serrez l'anneau autour de l'axe à l'aide d'une pince. Ces ajustements doivent être minimes (pas plus de 1 mm).

ES Inserte las ruedas en los orificios inferiores del armario. Si la rueda no se mantiene en su posición, afloje el anillo alrededor del eje separándolo con un destornillador. Si la rueda tiene dificultades para entrar en el agujero, apriete el anillo alrededor del eje con una abrazadera. Estos ajustes deben ser mínimos (no más de 1 mm).

PT Insira as rodas nos orifícios inferiores do armário. Se a roda não ficar na posição correcta, desaperte o anel à volta do eixo, abrindo-o com uma chave de fendas. Se a roda tiver dificuldade em entrar no orifício, aperte o anel à volta do eixo com uma pinça. Estes ajustamentos devem ser mínimos (não mais de 1 mm).

DE Setzen Sie die Räder in die unteren Löcher des Schrankes ein. Wenn das Rad nicht in seiner Position bleibt, lösen Sie den Ring um die Achse, indem Sie ihn mit einem Schraubenzieher spreizen. Lässt sich das Rad nur schwer in das Loch einführen, ziehen Sie den Ring um die Achse mit einer Klemme fest. Diese Einstellungen sollten minimal sein (nicht mehr als 1 mm).

IT Inserire le ruote nei fori inferiori del mobile. Se la ruota non rimane in posizione, allentare l'anello intorno all'asse allargandolo con un cacciavite. Se la ruota fatica a entrare nel foro, stringere l'anello intorno all'asse con un morsetto. Queste regolazioni devono essere minime (non più di 1 mm).

Two casters with brakes

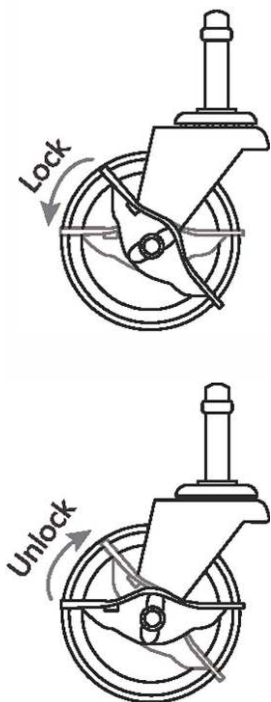

Locking system

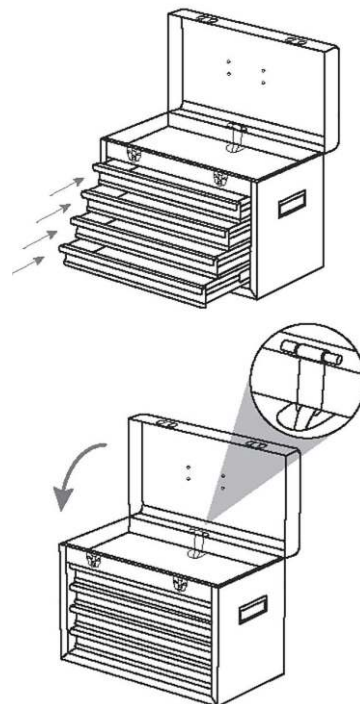

Drawers

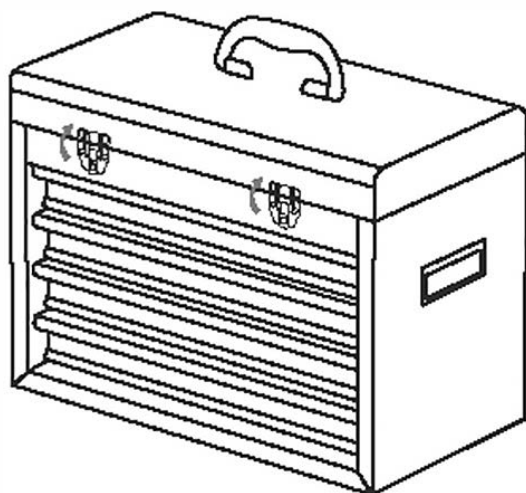

EN To unlock the drawers, open the tool chest, slide the drawers out and then close the tool chest. To lock the drawers, open the tool chest, slide the drawers in and then close the tool chest.

FR Pour déverrouiller les tiroirs, ouvrez la caisse à outils, faites glisser les tiroirs vers l'extérieur, puis refermez la caisse à outils. Pour verrouiller les tiroirs, ouvrez la caisse à outils, faites glisser les tiroirs vers l'intérieur, puis fermez la caisse à outils.

ES Para desbloquear los cajones, abra la caja de herramientas, deslice los cajones hacia fuera y, a continuación, cierre la caja de herramientas. Para bloquear los cajones, abra la caja de herramientas, deslice los cajones hacia dentro y, a continuación, cierre la caja de herramientas.

PT Para desbloquear as gavetas, abra a arca de ferramentas, faça deslizar as gavetas para fora e, em seguida, feche a arca de ferramentas. Para bloquear as gavetas, abra a arca de ferramentas, faça deslizar as gavetas para dentro e, em seguida, feche a arca de ferramentas.

DE Um die Schubladen zu entriegeln, öffnen Sie die Werkzeugkiste, schieben Sie die Schubladen heraus und schließen Sie dann die Werkzeugkiste. Um die Schubladen zu verriegeln, öffnen Sie die Werkzeugkiste, schieben Sie die Schubladen hinein und schließen Sie dann die Werkzeugkiste.

IT Per sbloccare i cassetti, aprire la cassetta degli attrezzi, far scorrere i cassetti verso l'esterno e poi chiuderla. Per bloccare i cassetti, aprire la cassetta degli attrezzi, far scorrere i cassetti verso l'interno e poi chiuderla.

If you have any questions, please contact our customer care center, Our contact details are below:

US

 001-877-644-9366

 customerservice@aosom.com

Imported by Aosom LLC
27150 SW Kinsman Rd Wilsonville, OR 97070 USA
MADE IN CHINA

If you have any questions, please contact our customer care center, Our contact details are below:

CA

 416-792-6088

 customerservice@aosom.ca

Imported by Aosom Canada Inc.
7270 Woodbine Avenue, Unit 307, Markham,
Ontario Canada L3R 4B9
MADE IN CHINA

Si vous avez la moindre question, veuillez contacter notre centre d'assistance à la clientèle, Nos coordonnées sont les suivantes:

 416-792-6088

 customerservice@aosom.ca

Importé par Aosom Canada Inc.
7270 Woodbine Avenue, unité 307,
Markham, Ontario Canada L3R 4B9
FABRIQUÉ EN CHINE

If you have any questions, please contact our customer care center, Our contact details are below:

UK

 0044-800-240-4004

 enquiries@mhstar.co.uk

IMPORTER ADDRESS:
MH STAR UK LTD
Unit 27, Perivale Park,
Horsenden lane South
Perivale, UB6 7RH
MADE IN CHINA

Si vous avez la moindre question, veuillez contacter notre centre d'assistance à la clientèle, Nos coordonnées sont les suivantes:

 0033-1-84166106

 aosom@mhfrance.fr

Importé par/Fabricant/REP:
MH FRANCE
2 Rue Maurice Hartmann
92130 Issy Les Moulineaux
France
FABRIQUÉ EN CHINE

Wenn Sie Fragen haben, wenden Sie sich bitte an unser Kundendienstzentrum, Unsere Kontaktdaten stehen unten:

DE

 0049-0(40)-88307530

 service@aosom.de

ADRESSE DES IMPORTEURE/Hersteller/REP:
MH Handel GmbH
Wendenstraße 309
D-20537 Hamburg
Germany
IN CHINA HERGESTELLT

In caso di dubbio, si prega di contattare il nostro centro assistenza clienti, I nostri dettagli di contatto sono di seguito:

IT

 0039-0249471447

 clienti@aosom.it

IMPORTATO DA/Produttore/REP:
AOSOM Italy srl
Centro Direzionale Milanofiori
Strada 1 Palazzo F1
20057 Assago (MI)
P.I.: 08567220960
FATTO IN CINA

Si tiene alguna pregunta, comuníquese con nuestro Centro de Atención al Cliente, Nuestros datos de contacto son los siguientes:

ES

 0034-931294512

 atencioncliente@aosom.es

IMPORTADOR/Fabricante/REP:
SPANISH AOSOM, S.L.
C/ROC GROS, N°15.08550, ELS HOSTALETES DE
BALENYÀ, SPAIN.
B66295775
HECHO EN CHINA

Se tiver alguma dúvida, por favor contacte o nosso Centro de Atendimento ao Cliente, Os nossos dados de contacto são os seguintes:

PT

 0034-931294512

 info@aosom.pt.

IMPORTADOR/Fabricante/REP:
SPANISH AOSOM, S.L.
C.ROC GROS N.15, 08550. ELS HOSTALETES DE
BALENYÀ
FEITO NA CHINA

Si vous avez la moindre question, veuillez contacter notre centre d'assistance à la clientèle, Nos coordonnées sont les suivantes:

FR

 0033-1-84166106

 aosom@mhfrance.fr

Importé par/Fabricant/REP:
MH FRANCE
2 Rue Maurice Hartmann
92130 Issy Les Moulineaux
France
FABRIQUÉ EN CHINE



FR

**DONNEZ
OU
RECYCLEZ**



ASSOCIATION

OU



LIVRAISON

OU



DÉCHÈTERIE

Adresses sur quefairedemesdechets.fr