

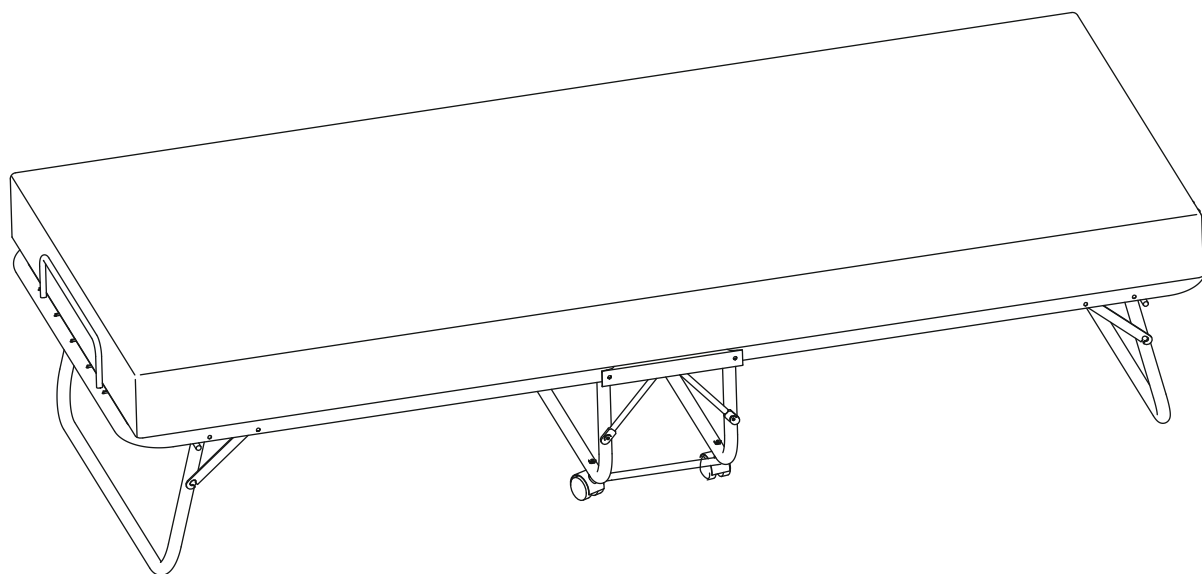

IN240300237V01_GL

831-754V00_831-754V70



EN_IMPORTANT, RETAIN FOR FUTURE REFERENCE: READ CAREFULLY.

FR_IMPORTANT: A LIRE ATTENTIVEMENT ET A CONSERVER POUR VOUS Y REFRERER ULTERIEUREMENT

ES_IMPORTANTE, LEA DETENIDAMENTE Y GUARDE PARA FUTURAS REFERENCIAS.

PT_IMPORTANTE, GUARDE PARA FUTURA REFERÊNCIA, LEIA ATENTAMENTE.

DE_WICHTIG! SORFGFÄLTIG LESEN UND FÜR SPÄTERES NACHSCHLAGEN AUFBEWAHREN.

IT_IMPORTANTE, LEGGERE E CONSERVARE QUESTO MANUALE D'ISTRUZIONE PER UN USO FUTURO.

EN

Dear customer,

Thank you for purchasing this product. So that your appliance serves you well, please read all the instructions in this user's manual. If you have any questions, please contact our customer care center.

FR

Cher client,

Nous vous remercions d'avoir acheté ce produit. Afin que vous puissiez profiter pleinement de votre appareil, veuillez lire toutes les instructions de ce manuel d'utilisation. Si vous avez la moindre question, veuillez contacter notre centre d'assistance à la clientèle.

DE

Sehr geehrter Kunde,

Vielen Dank, dass Sie dieses Produkt erworben haben. Damit Ihr Produkt Ihnen gute Dienste leistet, lesen Sie bitte alle Hinweise in diesem Benutzerhandbuch. Wenn Sie Fragen haben, wenden Sie sich bitte an unser Kundendienstzentrum.

ES

Queridos clientes,

Gracias por comprar este producto. Para que su electrodoméstico le sirva mejor, lea todas las instrucciones de este manual del usuario. Si tiene alguna pregunta, comuníquese con nuestro Centro de Atención al Cliente.

PT

Caros clientes,

Obrigado por adquirir este produto. Para que o seu aparelho o sirva melhor, leia todas as instruções deste manual do utilizador. Se tiver alguma dúvida, por favor contacte o nosso Centro de Atendimento ao Cliente.

IT

Caro Cliente,

Grazie per aver acquistato questo prodotto. Per servirti meglio con questo apparecchio ti prego di leggere tutte le istruzioni in presente manuale utente. In caso di dubbio, si prega di contattare il nostro centro assistenza clienti.

EN_Our contact details are below:



FR_Nos coordonnées sont les suivantes:

DE_Unsere Kontaktdaten stehen unten:

ES_Nuestros datos de contacto son los siguientes:

PT_Os nossos dados de contacto são os seguintes:

IT_I nostri dettagli di contatto sono di seguito:

Country	 Phone	 Email
UK	0044-800-240-4004	enquiries@mhstar.co.uk
DE	0049-(0)40-88307530	service@aosom.de
FR	0033-1-84166106	aosom@mhfrance.fr
ES	0034-931294512	atencioncliente@aosom.es
PT	0034-931294512	info@aosom.pt.
IT	0039-0249471447	clienti@aosom.it
US	001-877-644-9366	customerservice@aosom.com
CA	416-792-6088	customerservice@aosom.ca



CAUTION

EN

READ THE INSTRUCTION MANUAL BEFORE ASSEMBLING

- open the hardware as needed
- assemble in an area with plenty of space
- read each step before beginning construction
- never force the screws or fittings
- keep this manual for future reference
- tighten all the screws every 6 months
- do not shift or drag the product after assembly
- power tools should not be used to assemble this product



CAUTION

FR

LIRE LE MANUEL D'INSTRUCTIONS AVANT L'ASSEMBLAGE

- ouvrir les pièces détachées au besoin
- assembler dans une zone dégagée
- lire chaque étape avant de commencer la construction
- ne jamais forcer les vis ou les raccords
- conserver ce manuel pour référence ultérieure
- resserrer toutes les vis tous les 6 mois
- ne pas déplacer ou traîner le produit après l'assemblage
- les outils électriques ne doivent pas être utilisés pour assembler ce produit



ACHTUNG

DE

VOR DEM ZUSAMMENBAU DIE BEDIENUNGSANLEITUNG LESEN

- Bei Bedarf das Zubehör öffnen
- In einem Raum mit viel Platz montieren
- Jeden Schritt lesen, bevor mit dem Aufbau begonnen wird
- Die Schrauben oder Fittings nicht gewaltsam eindrehen
- Diese Anleitung zur späteren Verwendung aufbewahren
- Alle Schrauben alle 6 Monate nachziehen
- Das Produkt nach dem Zusammenbau nicht verschieben oder ziehen
- Elektrowerkzeuge sollten nicht zum Zusammenbau dieses Produkts verwendet werden



PRECAUCIÓN

ES

LEA EL MANUAL DE INSTRUCCIONES ANTES DEL ENSAMBLAJE

- Abrir el hardware según sea necesario
- Ensamblar en un área con mucho espacio
- Leer cada paso antes de comenzar la construcción
- No forzar los tornillos o accesorios
- Guardar este manual para referencia futura
- Apretar todos los tornillos cada 6 meses
- No mover o arrastrar el producto después del montaje
- No se deben utilizar herramientas eléctricas para montar este producto



PRECAUÇÕES

PT

LEIA O MANUAL DE INSTRUÇÕES ANTES DE MONTAR

- Abrir o hardware conforme necessário
- Montar em uma área com bastante espaço
- Ler cada etapa antes de iniciar a construção
- Nunca force os parafusos ou encaixes
- Guarde este manual para referência futura
- Apertar todos os parafusos a cada 6 meses
- Não mova ou arraste o produto após a montagem
- Ferramentas elétricas não devem ser usadas para montar este produto



ATTENZIONE

IT

LEGGERE IL MANUALE DI ISTRUZIONI PRIMA DI MONTARE

- Aprire l'hardware se necessario
- Montare in un'area con abbondante spazio
- Leggere ogni passaggio prima di iniziare la costruzione
- Non forzare mai le viti o gli accessori
- Conservare questo manuale per riferimento futuro
- Serrare tutte le viti ogni 6 mesi
- Non spostare o trascinare il prodotto dopo il montaggio
- Gli attrezzi elettrici non devono essere utilizzati per montare questo prodotto

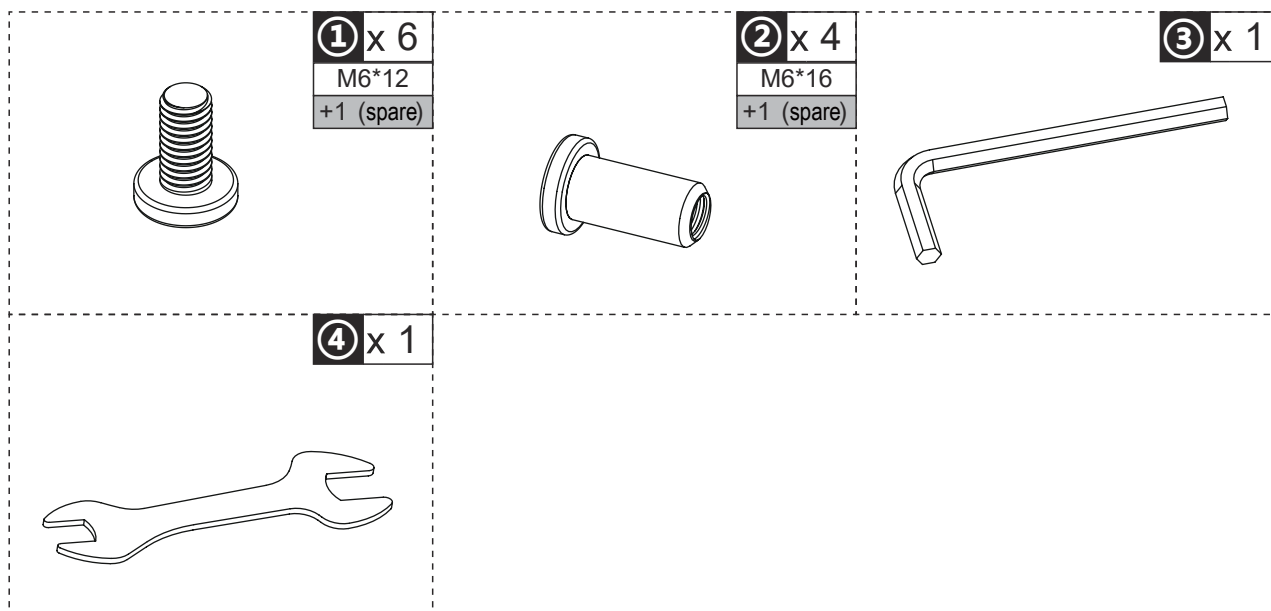
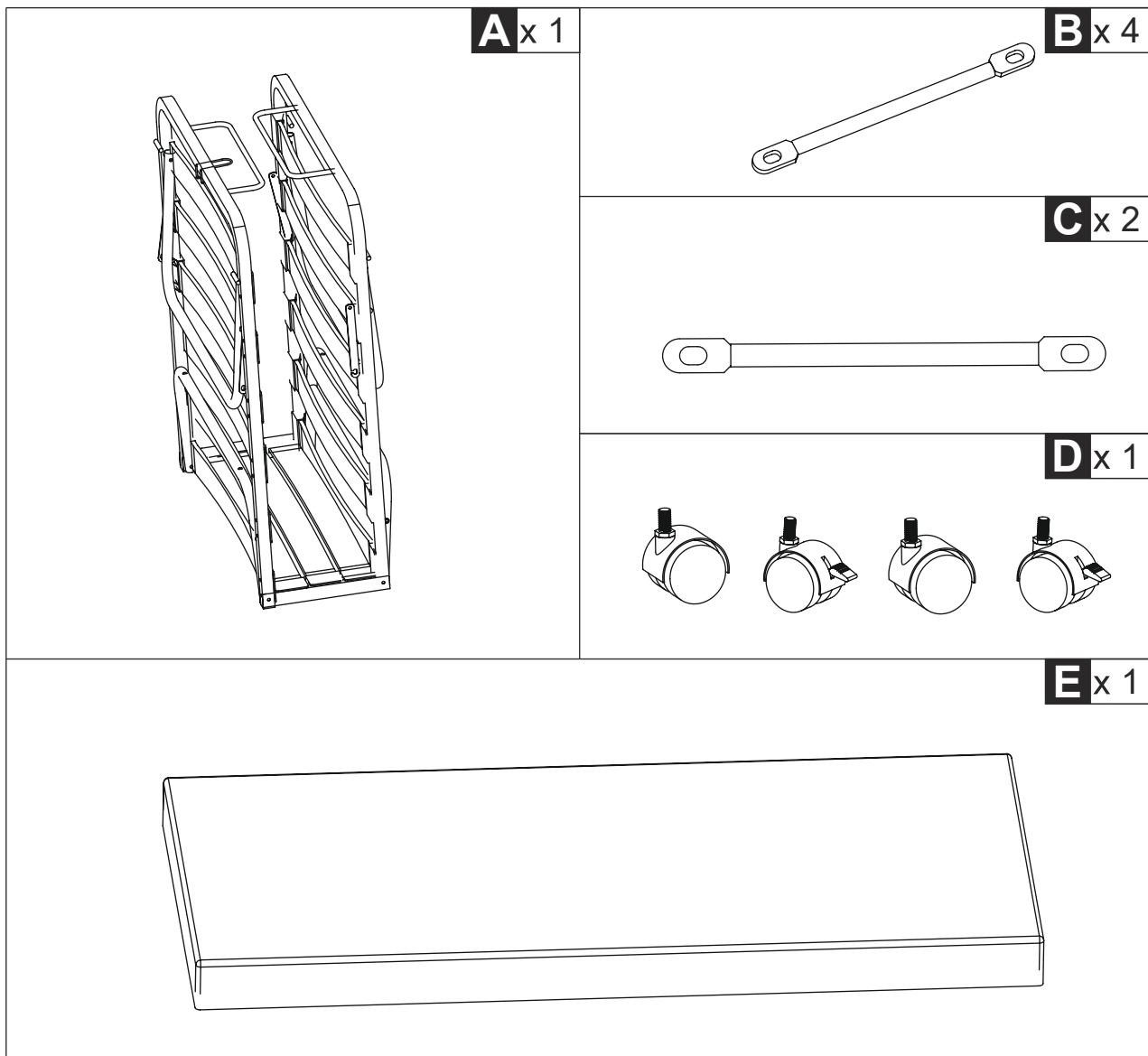



A

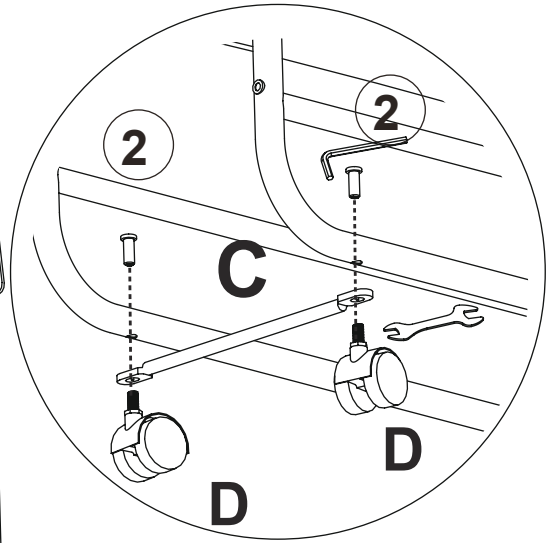
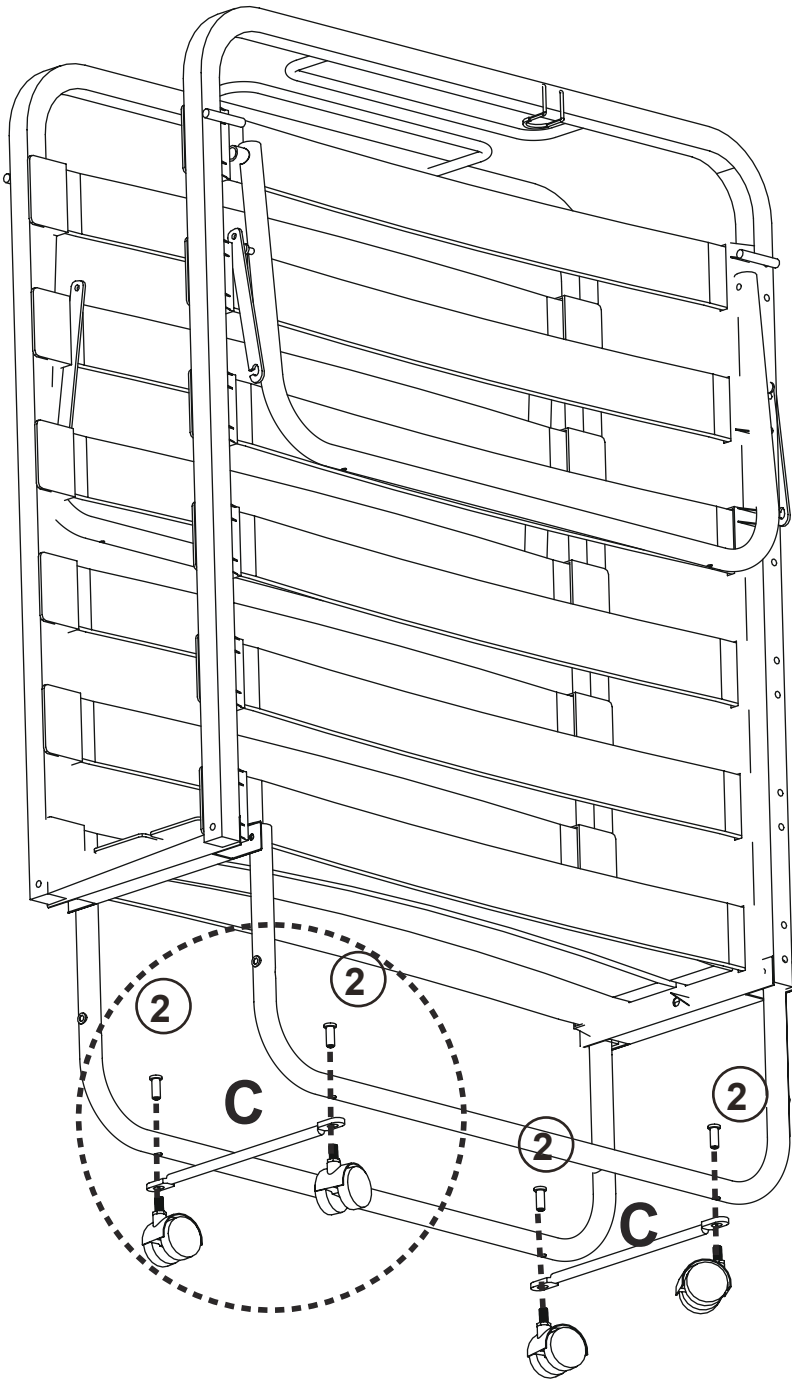

D

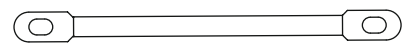

C x 2

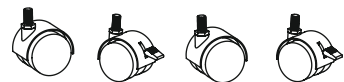

D x 1

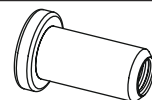

2 x 4

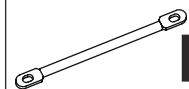
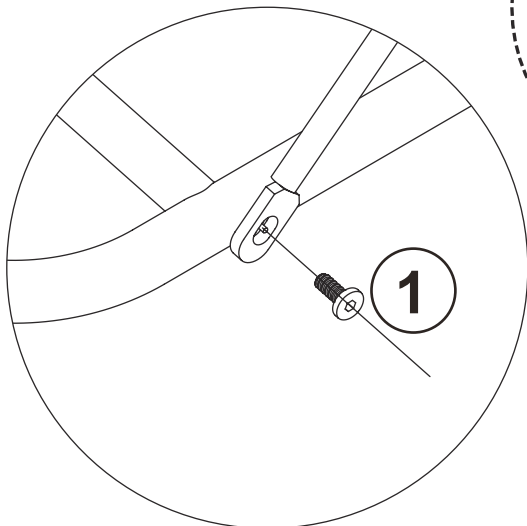
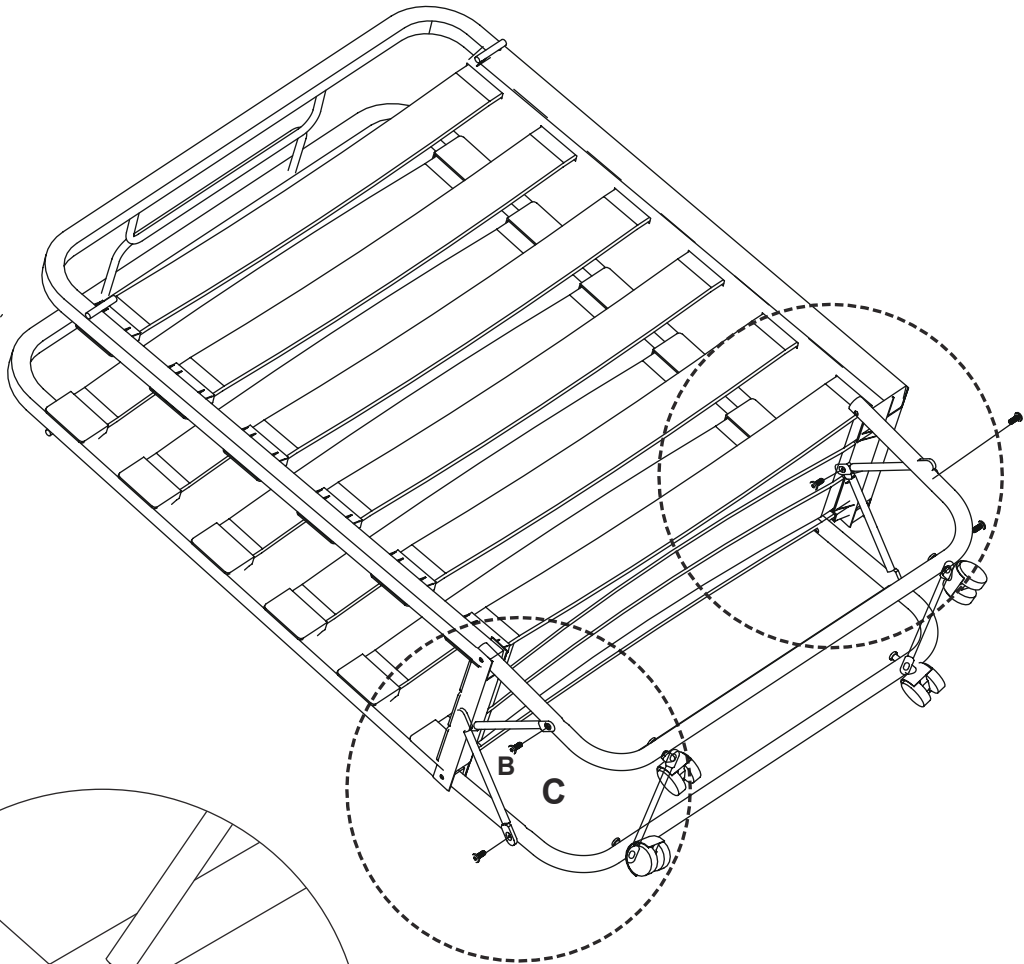
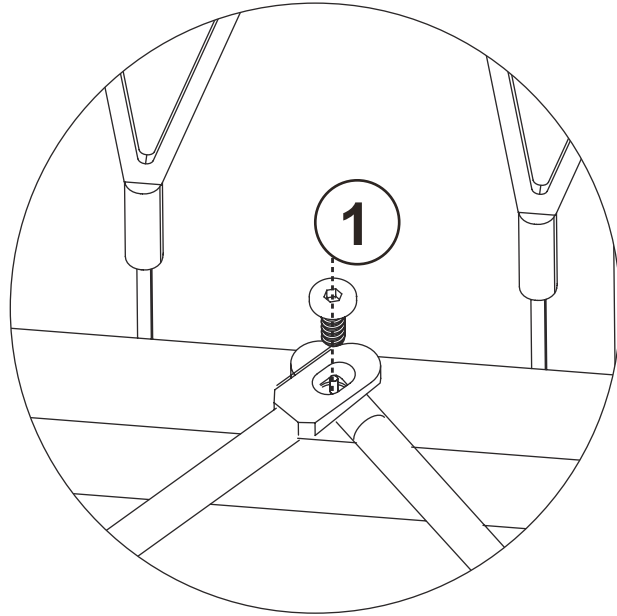

B x 4

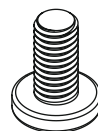

1 x 6

03

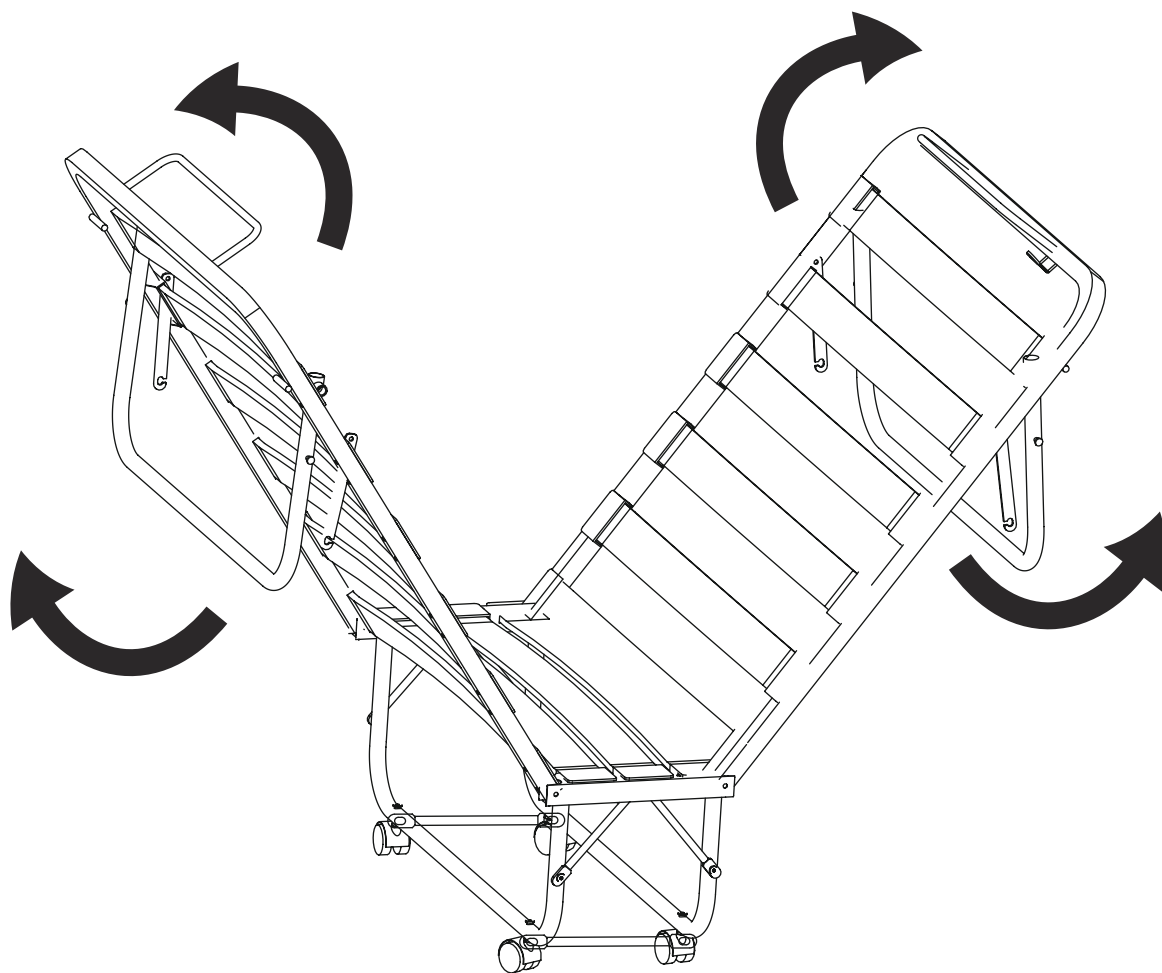

04



EN: This step is necessary. Otherwise it will cause component deformation.

FR: Cette étape est nécessaire. Sinon, elle entraînera une déformation des composants.

ES: Este paso es necesario. De lo contrario, causará deformación de los componentes.

PT: Essa etapa é necessária. Caso contrário, irá causar deformação dos componentes.

DE: Diese Schritt ist notwendig. Andernfalls kommt es zu einer Verformung der Komponenten.

IT: Questo passaggio è necessario. In caso contrario, provocherà deformazioni dei componenti.

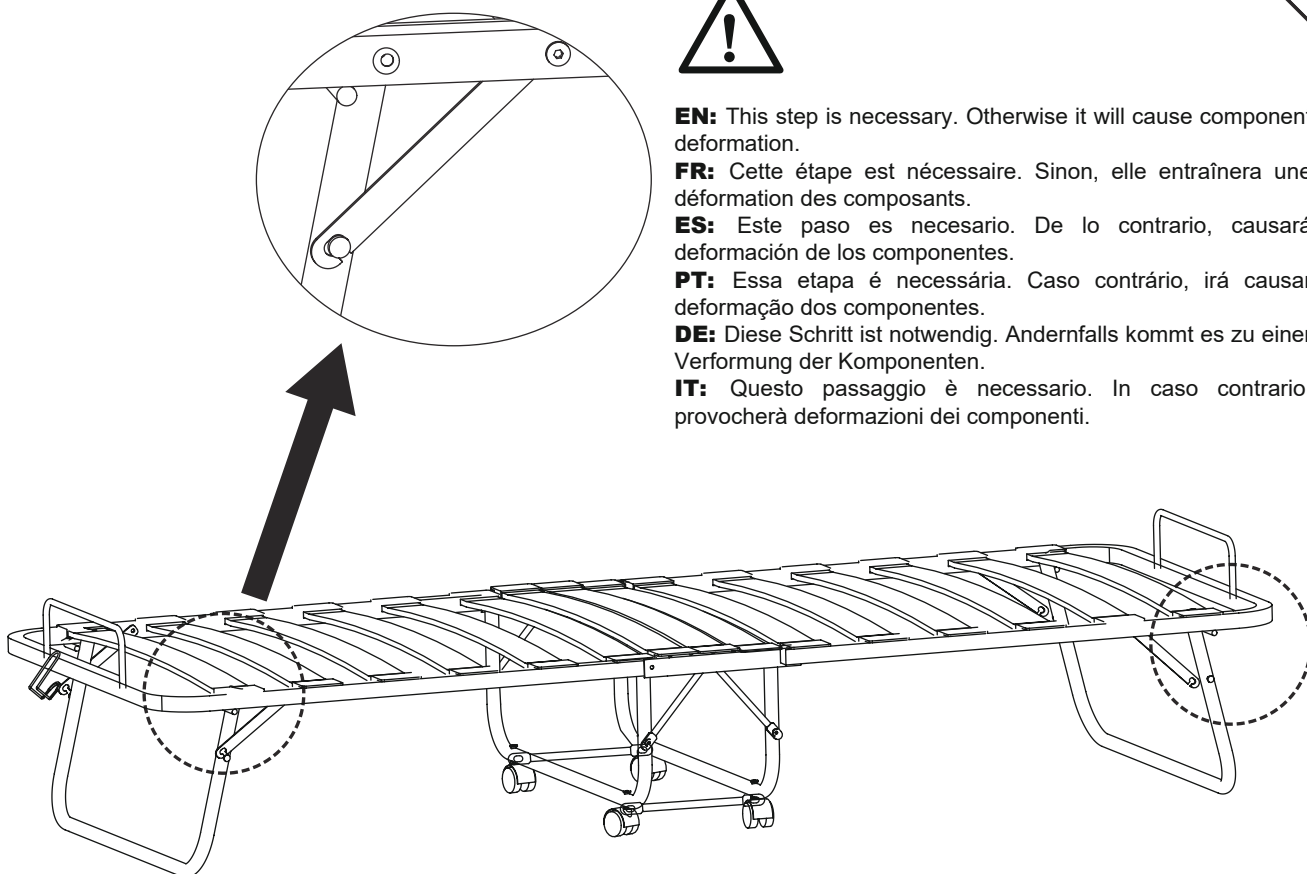

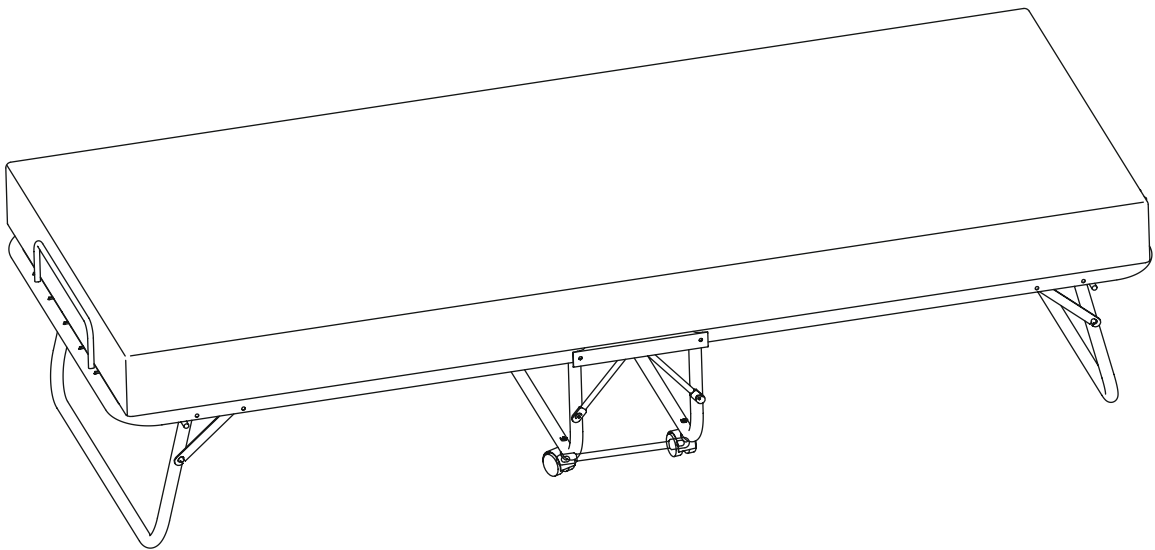
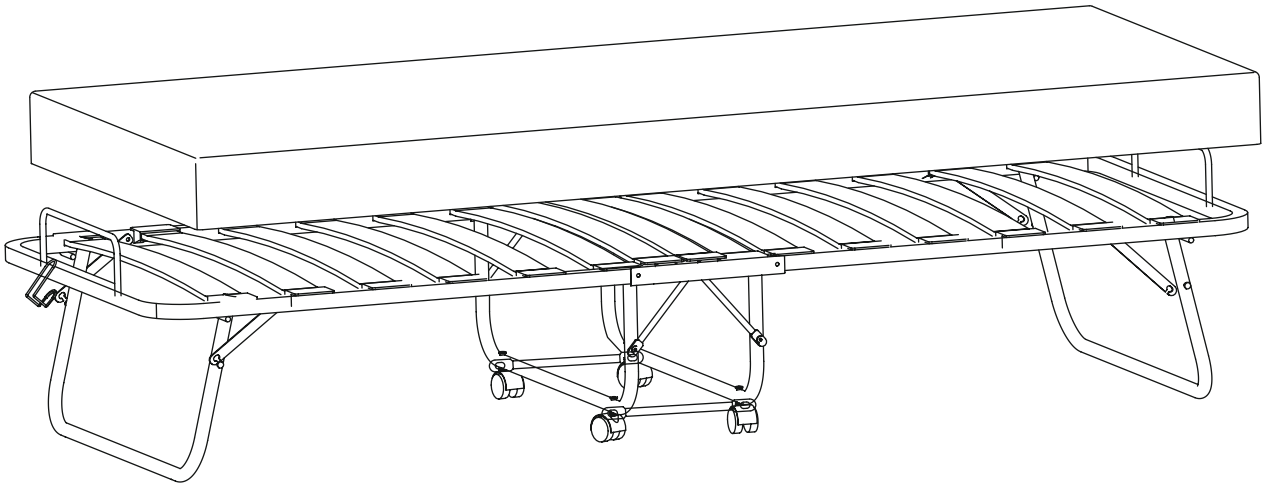

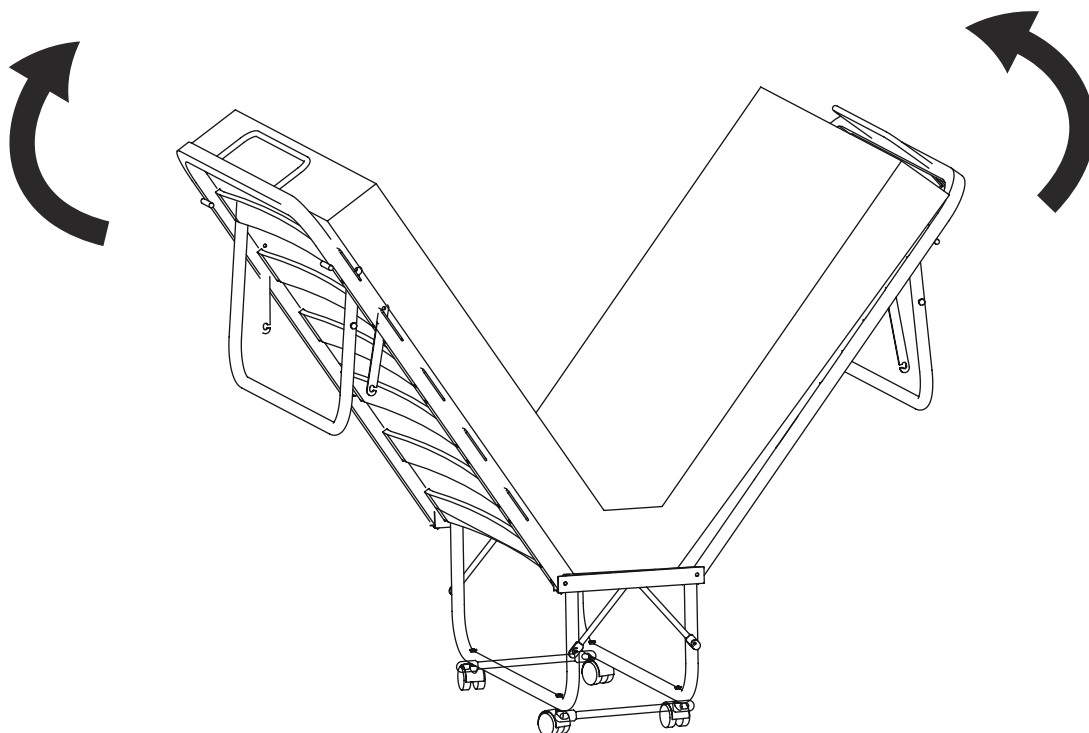

EN: When moving the folding bed, please do NOT pull the strap.

FR: Lorsque vous déplacez le lit pliant, veuillez NE PAS tirer sur la sangle.

ES: Al mover la cama plegable, por favor NO tire de la correa.

PT: Ao mover a cama dobrável, por favor NÃO puxe a alça.

DE: Beim Bewegen des Klappbettes bitte NICHT am Gurt ziehen.

IT: Quando si sposta il letto pieghevole, si prega di NON tirare la cinghia.

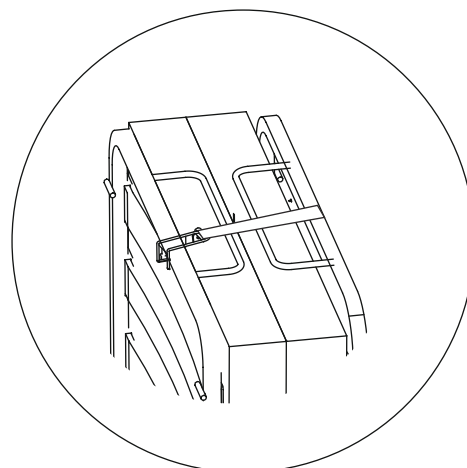
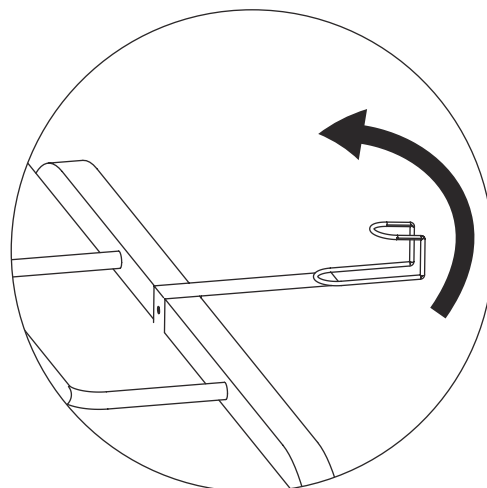
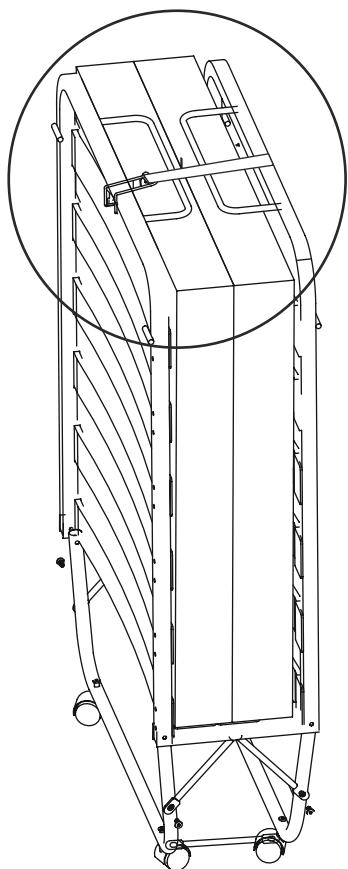

US_ IMPORTER:

Imported by Aosom LLC
 27150 SW Kinsman Rd Wilsonville, OR 97070 USA
 MADE IN CHINA

CA_ IMPORTER / IMPORTÉ PAR:

Imported by Aosom Canada Inc.
 7270 Woodbine Avenue, Unit 307, Markham, Ontario Canada L3R 4B9
 MADE IN CHINA

Importé par Aosom Canada Inc.
 7270 Woodbine Avenue, unité 307, Markham, Ontario Canada L3R 4B9
 Fabriqué en Chine

UK_ IMPORTER:

MH STAR UK LTD
 Unit 27, Perivale Park, Horsenden lane South
 Perivale, UB6 7RH
 MADE IN CHINA

DE_ IMPORTATEUR:

MH Handel GmbH
 Wendenstraße 309
 D-20537 Hamburg
 Germany
 IN CHINA HERGESTELLT

FR_ IMPORTÉ PAR:

MH France
 2, rue Maurice Hartmann
 92130 Issy-les-Moulineaux
 France
 Fabriqué en Chine



FR
DONNEZ
 OU
RECYCLEZ



OU



OU



ASSOCIATION

LIVRAISON

DÉCHÈTERIE

Adresses sur quefairedemesdechets.fr**IT_ IMPORTATO:**

AOSOM Italy srl
 Centro Direzionale Milanofiori
 Strada 1 Palazzo F1
 20057 Assago (MI)
 P.I.: 08567220960
 FATTO IN CINA

ES/PT_ IMPORTADOR:

SPANISH AOSOM, S.L.
 C/ ROC GROS, N° 15. 08550, ELS HOSTALET DE
 BALENYÀ, SPAIN.
 B66295775
 WWW.AOSOM.ES
 ATENCIONCLIENTE@AOSOM.ES
 TEL: 931294512
 HECHO EN CHINA

SPANISH AOSOM, S.L
 C.ROC GROS N.15, 08550. ELS HOSTALET DE BALENYÀ
 TEL: 931294512 (SEG-SEX DAS 7:30H ÀS 16:30H)
 INFO@AOSOM.PT
 WWW.AOSOM.PT