

831-888V70_831-888V90

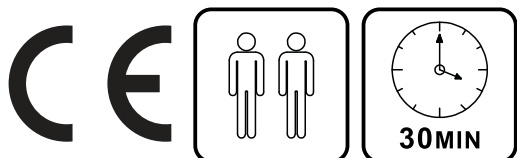

EN_IMPORTANT, RETAIN FOR FUTURE REFERENCE: READ CAREFULLY.

FR_IMPORTANT : A LIRE ATTENTIVEMEN ET A CONSERVER POUR VOUS Y REFERER ULTERIEUREMENT.

ES_IMPORTANTE, LEA Y GUARDE PARA FUTURAS REFERENCIAS.

PT_IMPORTANTE, RETER PARA REFERÊNCIA FUTURA: LEIA ATENTAMENTE.

DE_WICHTIG! SORGFÄLTIG LESEN UND FÜR SPÄTER NACHSCHLAGEN AUFBEWAHREN.

IT_IMPORTANTE! CONSERVARE IL PRESENTE MANUALE PER FUTURO RIFERIMENTO E LEGGERLO ATTENTAMENTE.

WARNING AND SAFETY INSTRUCTIONS

Before assembly, carefully read this instruction manual. Refer back to this manual when installing the product to ensure it is fitted safely and correctly. Keep these instructions for future use.

WARNING Risk of fire and electric shock

- All fittings must be installed in accordance with current IEE wiring regulations. If in doubt, consult a qualified electrician.
- Switch off the electrical supply at the main circuit board before installation and maintenance.
- For indoor use only. This product should be positioned well away from curtains and fabrics. Never cover the mirror.
- Regularly check the cord, the transformer and all other parts for damage. If damages are found, do not use this product.

INSTALLATION SAFETY

- Before installation, ensure the product is not damaged or has missing parts. Handle the product with care.
- Ensure there are no hidden pipes or cables in the wall before drilling.
- Wear suitable eye protection when drilling. Take care if drilling on tiled surfaces, just in case the drill slips.

NOTE: The important safeguards and instructions that appear in this manual are not meant to cover all possible conditions and situations that may occur. It must be understood that common sense, caution and care, are factors that can't be built into any product. These factors must be supplied by the person(s) caring for and operating the product. Do not install this product in hazardous locations.

ACCESSORY PACKAGE

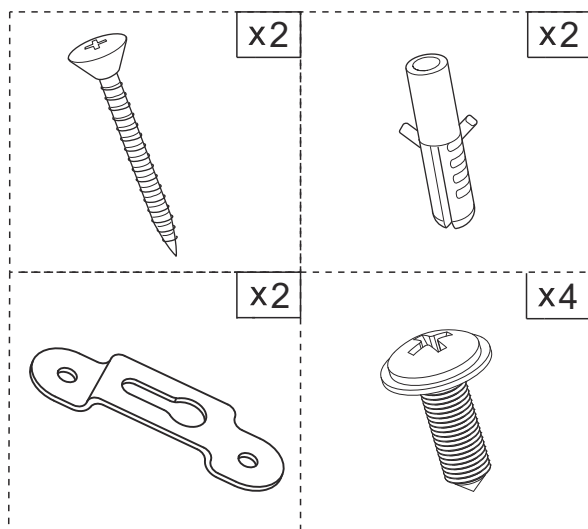

TOOLS YOU MAY NEED



INSTALIATION

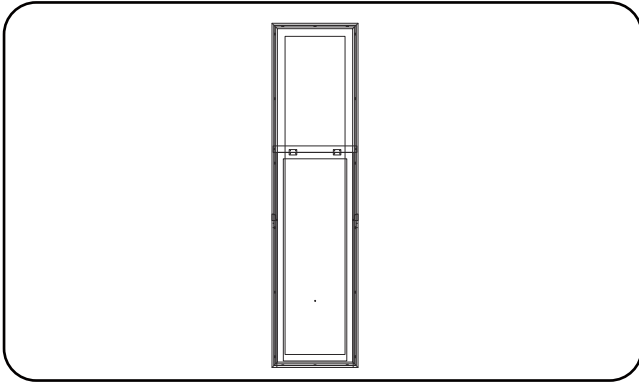

1. Measure the distance of the hanging hole.

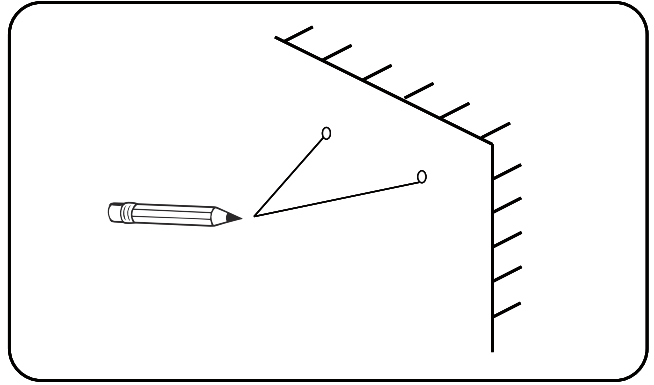

2. Mark the hole position on the wall.

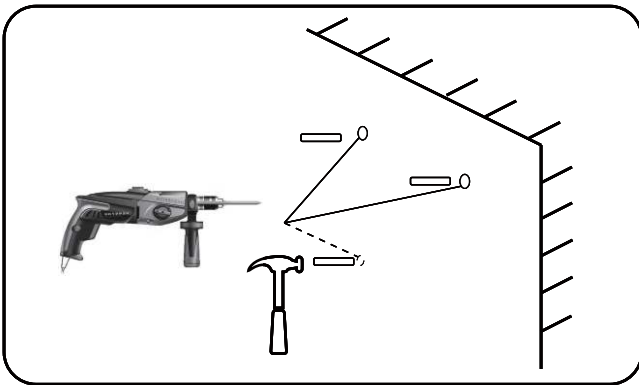

3. Drill the holes and place the suitable plastic anchors.

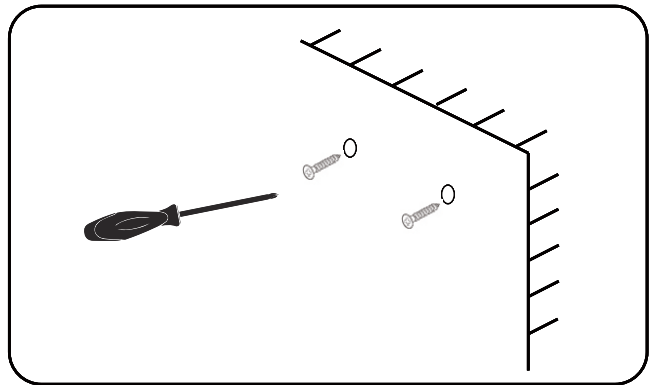

4. Arrange the screws on the wall, leaving about 3/8 inch outside the wall, and make sure the screws are stable.

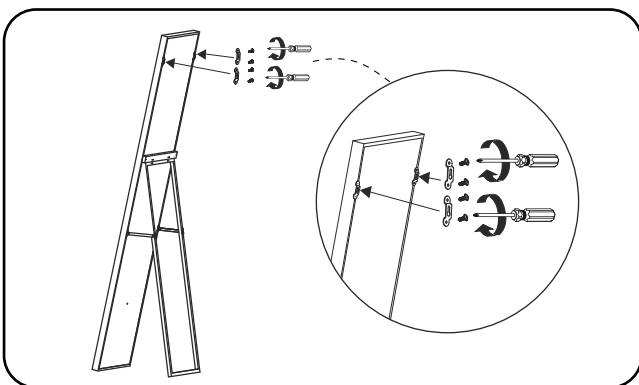

5. Use a screwdriver to install the hook on the frame.

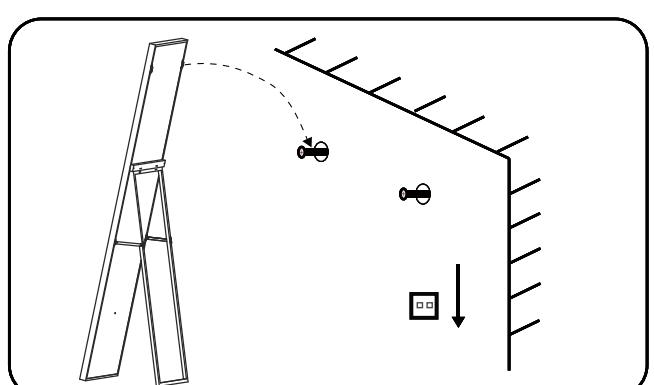

6. Hang the mirror on the screw

OPERATION INSTRUCTION



ON/OFF button



- Button lights up when connected to main supply.
 - Touch the button to turn on/off the mirror
 - Hold the button to adjust the brightness.
 - Confirm the setting by removing your finger when it reaches the colour you need.
-

AFTERCARE INSTRUCTIONS

Before cleaning, ensure the mirror is turned off.

Clean using a soft and dry cloth. Never use cleaning agents or abrasive materials. Do not allow moisture to come into contact with the lamp.

AVERTISSEMENT ET CONSIGNES DE SÉCURITÉ

Avant l'assemblage, lisez attentivement ce manuel d'instructions. Reportez-vous à ce manuel lors de l'installation du produit pour s'assurer qu'il est monté correctement et en toute sécurité. Conservez ces instructions pour une utilisation ultérieure.

AVERTISSEMENT Risque d'incendie et de choc électrique

- Tous les raccords doivent être installés conformément à la réglementation en vigueur en matière de câblage IEE. En cas de doute, consultez un électricien qualifié.
- Coupez l'alimentation électrique au niveau de la carte de circuit principal avant l'installation et l'entretien.
- Utilisation à l'intérieur uniquement. Ce produit doit être placé bien loin des rideaux et des tissus. Ne couvrez jamais le miroir.
- Vérifiez régulièrement que le cordon, le transformateur et toutes les autres pièces ne sont pas endommagés. Si des dommages sont constatés, n'utilisez pas ce produit.

SÉCURITÉ D'INSTALLATION

- Avant l'installation, assurez-vous que le produit n'est pas endommagé ou qu'il ne manque pas de pièces. Manipulez le produit avec précautions.
- Assurez-vous qu'il n'y a pas de tuyaux ou de câbles cachés dans le mur avant le perçage.
- Portez une protection oculaire appropriée lors du forage. Faites attention si vous percez sur des surfaces carrelées, juste au cas où la perceuse glisse.



Prudence

Ce produit contient une source lumineuse de classe d'efficacité énergétique <F>.

La source lumineuse de ce produit est constituée de diodes lumineuses non remplaçables (LED). Ne démontez pas le produit, car les diodes lumineuses peuvent endommager les yeux.

NOTE : Les garanties et les instructions importantes qui apparaissent dans ce manuel ne sont pas destinées à couvrir toutes les conditions et situations possibles qui peuvent se produire. Il convient de souligner le bon sens, la prudence et le soin sont des facteurs qui ne peuvent être intégrés dans aucun produit. Ces facteurs doivent être fournis par la ou les personnes la personne qui s'occupe du produit et l'utilise. N'installez pas ce produit dans des endroits dangereux.

PACK D'ACCESSOIRES

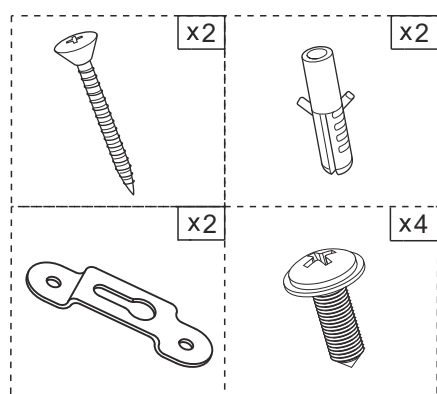

TOOLS YOU MAY NEED



INSTALLATION

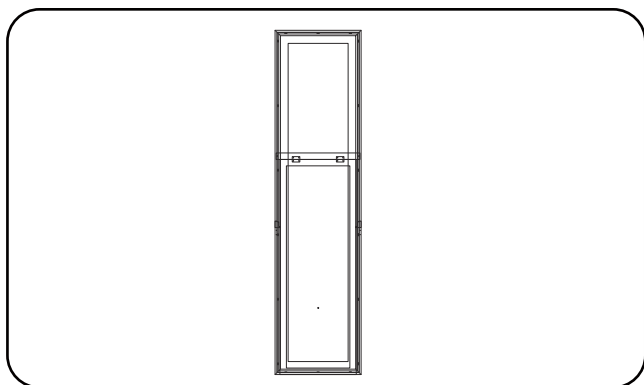

1. Mesurer la distance du trou de suspension

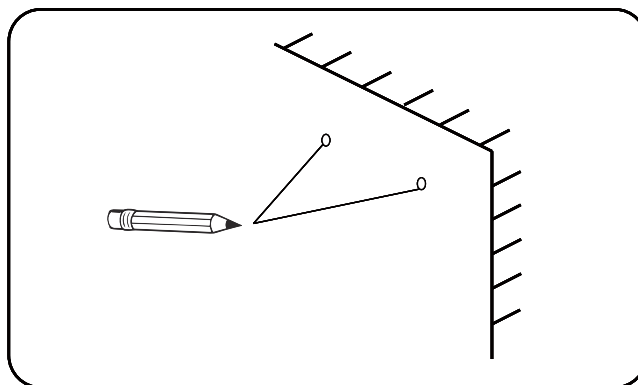

2. Marquez la position du trou sur le mur

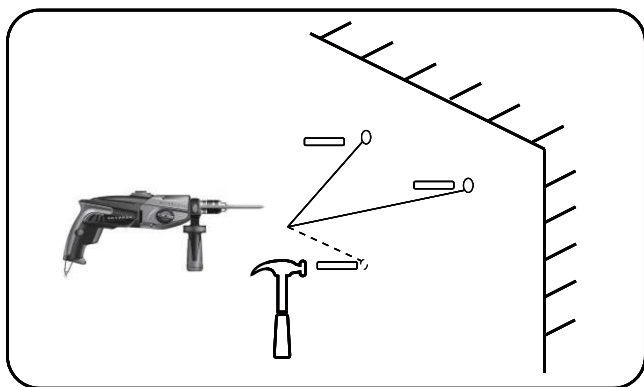

3. Percez les trous et placez les ancrages en plastique appropriés.

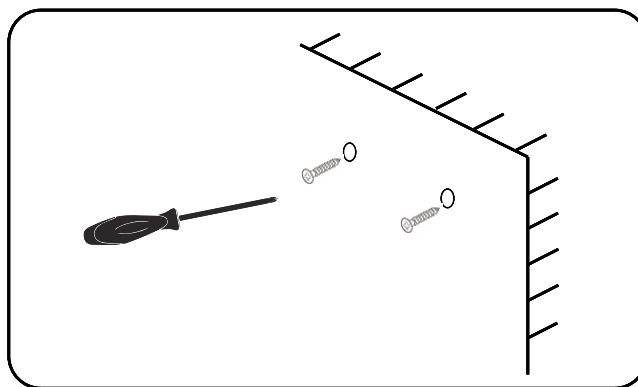

4. Disposez les vis sur le mur, en laissant environ 3/8 de pouce à l'extérieur du mur, et assurez-vous que les vis sont stables

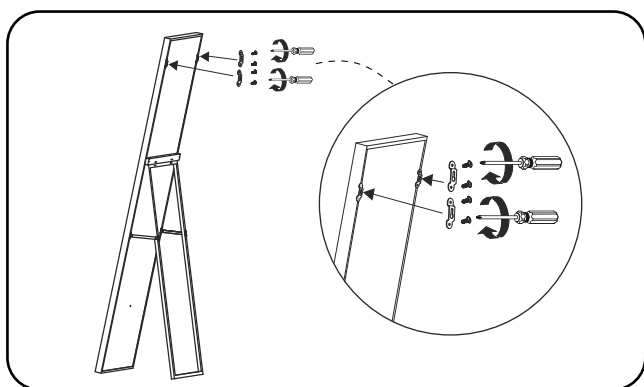

5. Utilisez un tournevis pour installer le crochet sur le cadre.

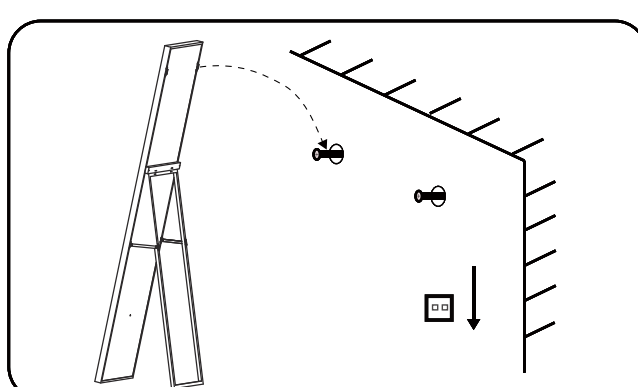

6. Accrochez le miroir à la vis

INSTRUCTIONS D'UTILISATION



Bouton ON/OFF



- Le bouton devient bleu lorsqu'il est connecté à l'alimentation principale.
 - Appuyez sur le bouton pour allumer/éteindre le miroir
 - Maintenez le bouton pour régler la luminosité.
 - Confirmez le réglage en retirant votre doigt lorsqu'il atteint la couleur souhaitée
-

INSTRUMENTS DE SUIVI

Avant le nettoyage, assurez-vous que le miroir est éteint.

Nettoyez à l'aide d'un chiffon doux et sec. N'utilisez jamais d'agents de nettoyage ou de matériaux abrasifs. Ne laissez pas l'humidité entrer en contact avec la lampe.

ADVERTENCIAS E INSTRUCCIONES DE SEGURIDAD

Antes del montaje, lea atentamente este manual de instrucciones. Vuelva a consultar este manual al instalar el producto para asegurarse de que se instala de forma segura y correcta. Guarde estas instrucciones para futuros usos.

RIESGO DE INCENDIO Y DESCARGA ELÉCTRICA

- Todos los accesorios deben instalarse de acuerdo con las normas de cableado actuales de IEE. Si tiene dudas, consulte a un electricista calificado.
- Desconecte la alimentación eléctrica en la placa de circuito principal antes de la instalación y el mantenimiento.
- Sólo para uso en interiores. Este producto debe colocarse lejos de cortinas y telas. Nunca se debe cubrir el espejo.
- Controle periódicamente el cable, el transformador y todas las demás piezas en busca de daños. Si se encuentran daños, no utilice este producto.

SEGURIDAD DE LAS INSTALACIONES

- Antes de la instalación, asegúrese de que el producto no está dañado ni le faltan piezas. Manipule el producto con cuidado.
- Asegúrese de que no haya tuberías o cables ocultos en la pared antes de perforar.
- Utilice protección ocular adecuada al taladrar. Tenga cuidado al taladrar en superficies alicatadas, por si el taladro resbala.



ATENCIÓN

Se incluye una fuente de luz de clase <F> de eficiencia energética.

La fuente de luz de este producto son diodos de luz (LED) no reemplazables. No desmonte el producto, ya que los diodos de luz pueden dañar los ojos.

NOTA: Las medidas de seguridad e instrucciones importantes que aparecen en este manual no pretenden cubrir todas las condiciones y situaciones posibles que pueden ocurrir. Debe entenderse que el sentido común, la precaución y el cuidado son factores que no se pueden incorporar a ningún producto. Estos factores deben ser suministrados por la(s) persona(s) que cuida(n) y opera(n) el producto. No instale este producto en lugares peligrosos.

PAQUETE DE ACCESORIOS

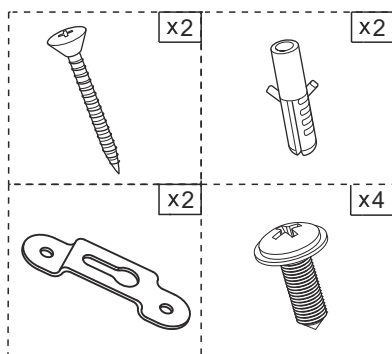

HERRAMIENTAS NECESARIAS



INSTALACIÓN

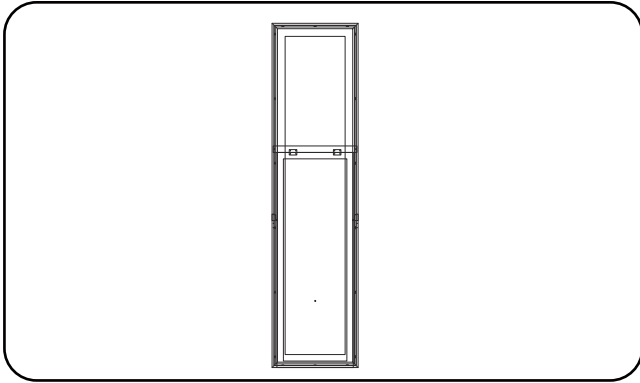

1. Mida la distancia del agujero para colgar.

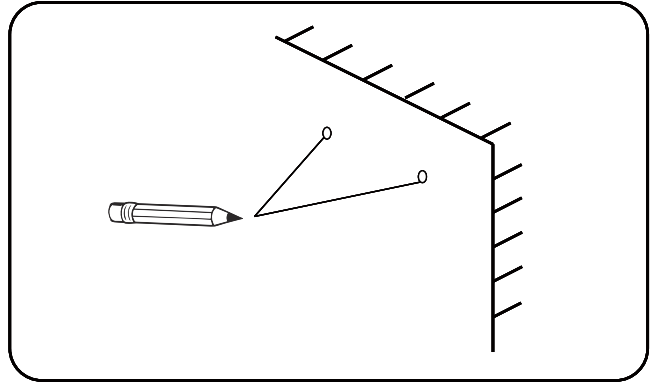

2. Marque la posición del agujero en la pared.

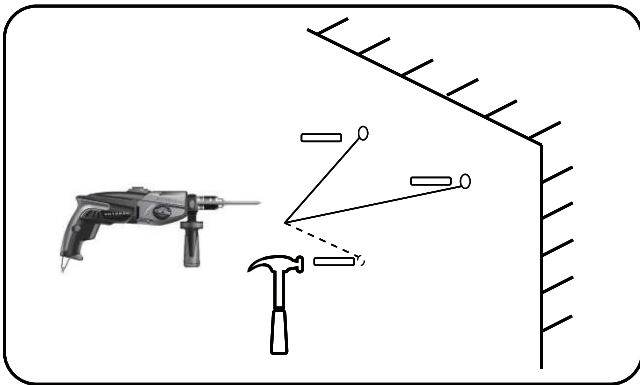

3. Taladre los agujeros y coloque los tacos de plástico adecuados.

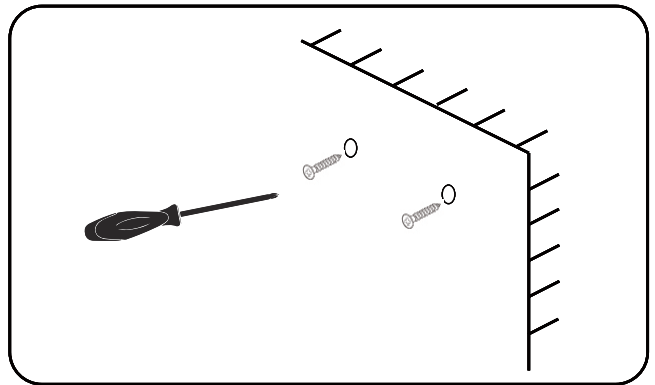

4. Arrange the screws on the wall, leaving about 3/8 inch outside the wall, and make sure the screws are stable

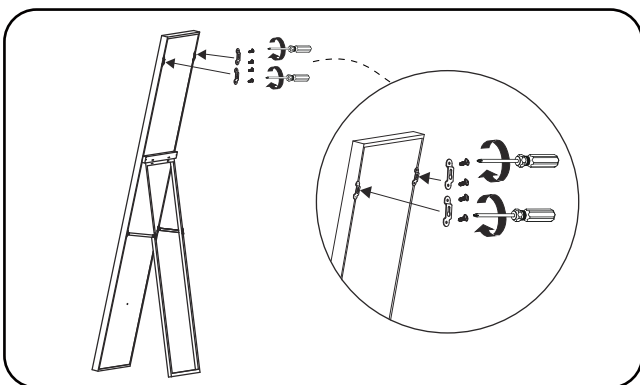

5. Utilice un destornillador para instalar el gancho en el marco.

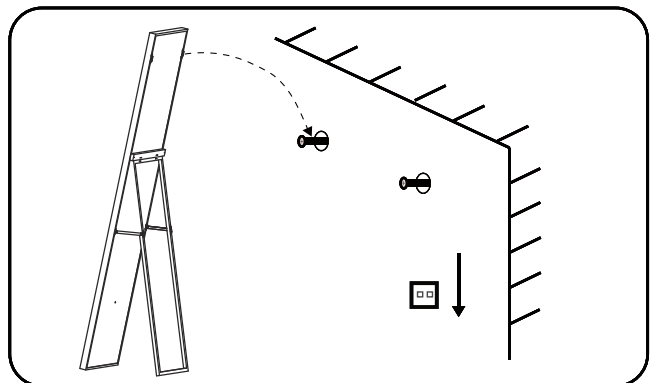

6. Cuelgue el espejo.

INSTRUCCIONES DE USO



botón ON/OFF



- El botón se vuelve azul cuando está conectado a la corriente.
- Toque el botón para encender o apagar el espejo.
- Mantenga pulsado el botón para ajustar el brillo.
- Confirme el ajuste retirando el dedo cuando alcance el color que necesita.

INSTRUCCIONES DE MANTENIMIENTO

Antes de limpiar, asegúrese de que el espejo esté apagado.

Limpiar con un paño suave y seco. Nunca use agentes de limpieza o materiales abrasivos. No permita que la humedad entre en contacto con la lámpara.

AVISO E INSTRUÇÕES DE SEGURANÇA

Antes da montagem, leia atentamente este manual de instruções. Consulte novamente este manual ao instalar o produto para garantir a sua montagem segura e correta. Guarde estas instruções para utilização futura.

ATENÇÃO Risco de incêndio e choque elétrico

- Todos os acessórios devem ser instalados de acordo com os regulamentos atuais da cablagem do IEE. Em caso de dúvida, consultar um eletricista qualificado.
- Desligar a alimentação elétrica na placa de circuitos principais antes da instalação e manutenção.
- Apenas para utilização em interiores. Este produto deve ser posicionado bem longe de cortinas e tecidos. Nunca cobrir o espelho.
- Verificar regularmente se o cabo, o transformador e todas as outras peças estão danificadas. Se forem encontrados danos, não utilizar este produto.

INSTALAÇÃO DE SEGURANÇA

- Antes da instalação, certifique-se de que o produto não está danificado ou tem peças em falta. Manusear o produto com cuidado.
- Certificar-se de que não há tubos ou cabos escondidos na parede antes da perfuração.
- Usar proteção adequada dos olhos ao perfurar. Ter cuidado ao perfurar em superfícies azulejadas, para o caso da broca deslizar.



ATENÇÃO

Este produto contém uma fonte de luz de classe de eficiência energética <F>.

A fonte de luz deste produto são díodos de luz não substituíveis (LED). Não desmontar o produto, pois os díodos luminosos podem danificar os olhos.

NOTA: As importantes precauções e instruções que aparecem neste manual não se destinam a cobrir todas as condições e situações possíveis que possam ocorrer. Deve entender-se que o bom senso, precaução e cuidado, são fatores que não podem ser incorporados em nenhum produto. Estes fatores devem ser fornecidos pela(s) pessoa(s) que cuida(m) e operacionaliza(m) o produto. Não instalar este produto em locais perigosos.

PACOTE DE ACESSÓRIOS

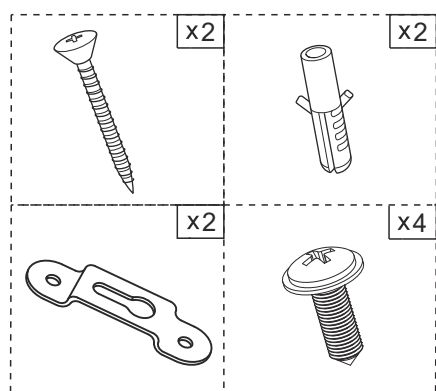

FERRAMENTAS DE QUE PODERÁ NECESSITAR



INSTALAÇÃO

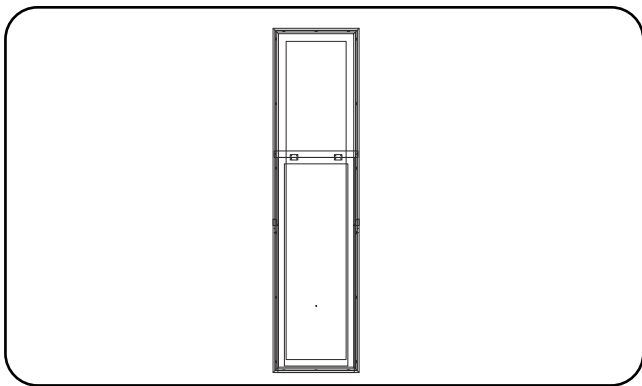

1. Meça a distância do orifício de suspensão

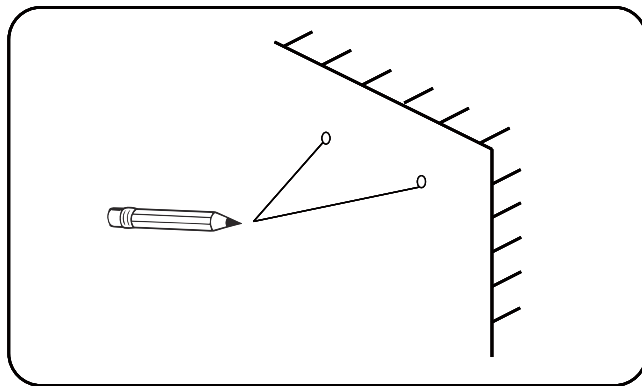

2. Marque a posição do furo na parede

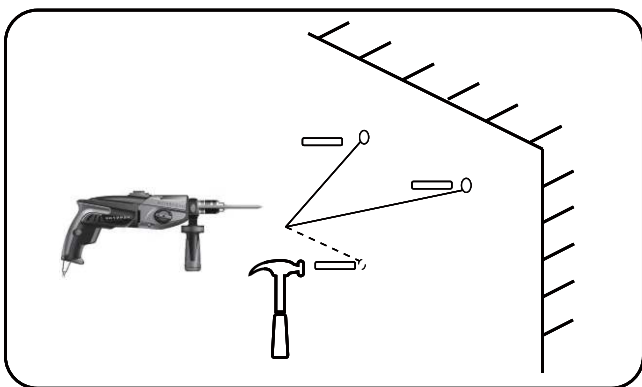

3. Faça os orifícios e coloque as âncoras de plástico adequadas.

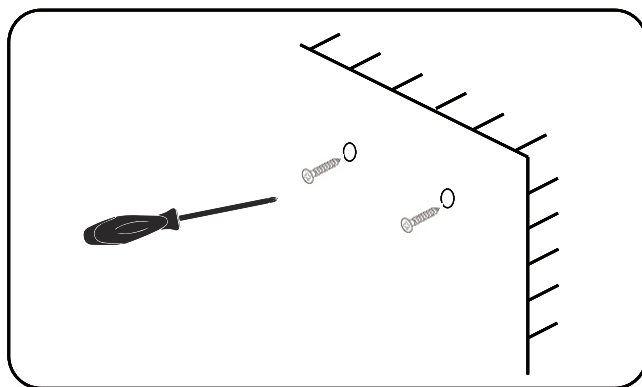

4. Disponha os parafusos na parede, deixando cerca de 3/8 de polegada fora da parede e certifique-se de que os parafusos estejam estáveis

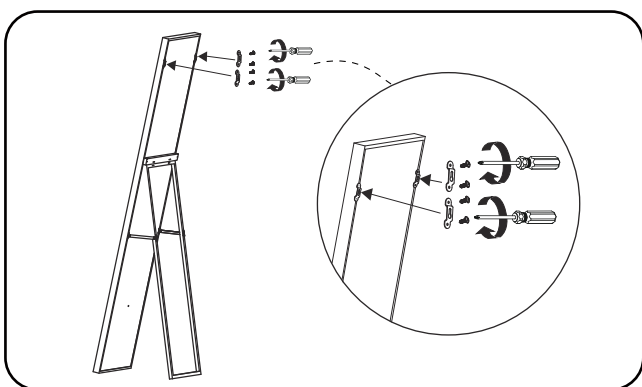

5. Use uma chave de fenda para instalar o gancho no quadro.

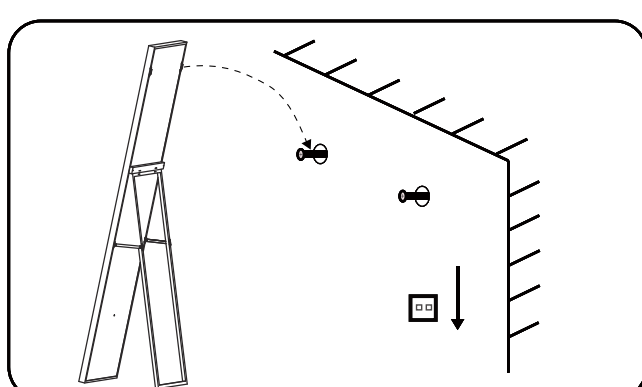

6. Pendurar o espelho no parafuso.

INSTRUÇÕES DE FUNCIONAMENTO



Botão ON/OFF



- O botão fica azul quando ligado ao fornecimento principal.
- Tocar no botão para ligar/desligar o espelho.
- Segurar o botão para ajustar a luminosidade.

INSTRUÇÕES DE CUIDADOS

Antes de limpar, certifique-se de que o espelho está desligado.

Limpar com um pano macio e seco. Nunca utilizar produtos de limpeza ou materiais abrasivos. Não permitir que a humidade entre em contacto com a lâmpada.

WARNUNG- UND SICHERHEITSHINWEISE

Lesen Sie diese Anleitung vor der Montage sorgfältig durch. Ziehen Sie diese Anleitung bei der Montage zu Rate, um sicherzustellen, dass das Produkt sicher und korrekt montiert wird. Bewahren Sie diese Anleitung für den späteren Gebrauch auf.

WARNUNG Brand- und Stromschlaggefahr

- Alle entsprechenden Installationen müssen in Übereinstimmung mit den aktuellen IEE-Verdrahtungsvorschriften durchgeführt werden. Wenden Sie sich im Zweifelsfall an einen qualifizierten Elektriker.
- Schalten Sie vor Installations- und Wartungsarbeiten die Hauptstromversorgung aus.
- Nur für den Gebrauch in Innenräumen. Dieses Produkt sollte nicht in der Nähe von Vorhängen oder Stoffen installiert werden. Den Spiegel niemals abdecken.
- Überprüfen Sie das Netzkabel, den Transformator und alle anderen Teile regelmäßig auf Beschädigungen. Wenn Sie Schäden feststellen, verwenden Sie dieses Produkt nicht.

SICHERHEIT BEI DER INSTALLATION

- Vergewissern Sie sich vor der Installation, dass das Produkt nicht beschädigt ist oder Teile fehlen. Behandeln Sie das Produkt mit Sorgfalt.
- Vergewissern Sie sich vor dem Bohren, dass sich keine Rohre oder Kabel in der Wand befinden.
- Tragen Sie beim Bohren eine geeignete Schutzbrille. Achten Sie beim Bohren auf Fliesen darauf, dass der Bohrer nicht abrutscht.



Vorsicht

Dieses Produkt enthält eine Lichtquelle der Energieeffizienzklasse <F>.

Die Beleuchtung dieses Produkts besteht aus nicht austauschbaren Leuchtdioden (LED). Das Produkt nicht zerlegen, da die Leuchtdioden die Augen schädigen können.

HINWEIS: Die wichtigen Sicherheitshinweise und Anweisungen in diesem Handbuch bedeuten nicht, dass alle möglichen Bedingungen und Situationen, die auftreten können, abgedeckt sind. Es muss klar sein, dass gesunder Menschenverstand, Vorsicht und Sorgfalt Faktoren sind, die nicht in ein Produkt eingebaut werden können. Diese Faktoren müssen von der/den Person(en) bereitgestellt werden, die für das Produkt verantwortlich ist/sind und es bedient/bedienen. Installieren Sie dieses Produkt nicht an gefährlichen Orten.

ZUBEHÖR.

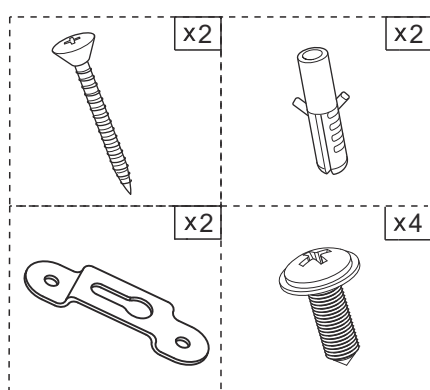

BENÖTIGTE WERKZEUGE



INSTALLATION

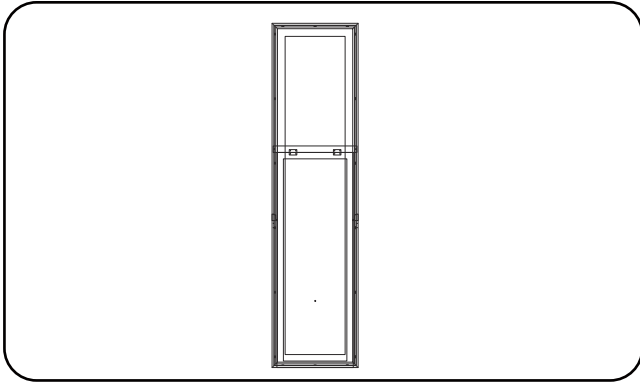

1. Messen Sie den Abstand des Aufhängelochs

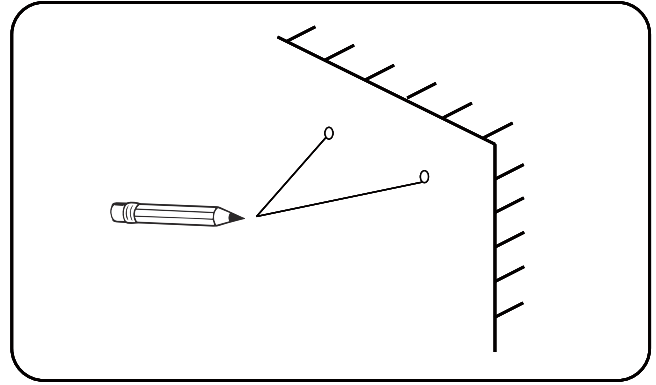

2. Markieren Sie die Lochposition an der Wand

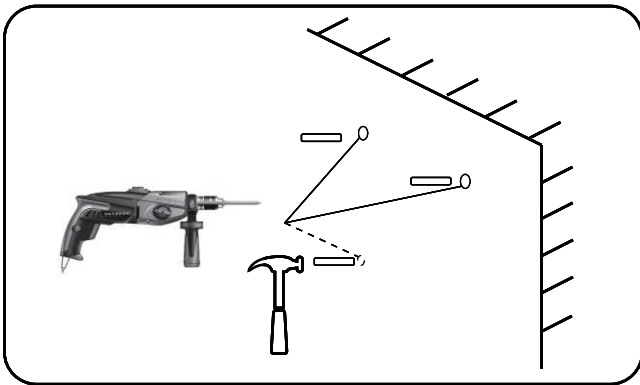

3. Löcher bohren und passende Kunststoffdübel einsetzen.

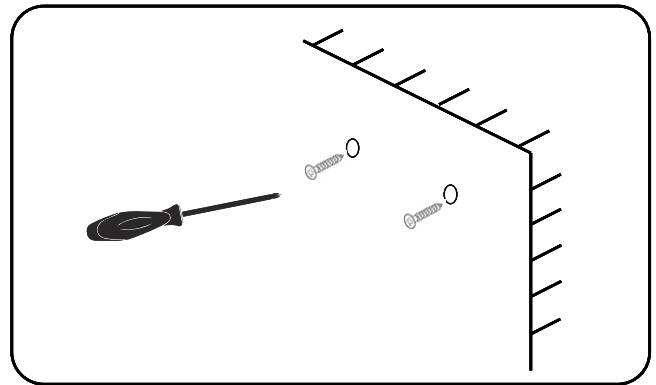

4. Ordnen Sie die Schrauben an der Wand an, lassen Sie etwa 3/8 Zoll außerhalb der Wand und stellen Sie sicher, dass die Schrauben stabil sind

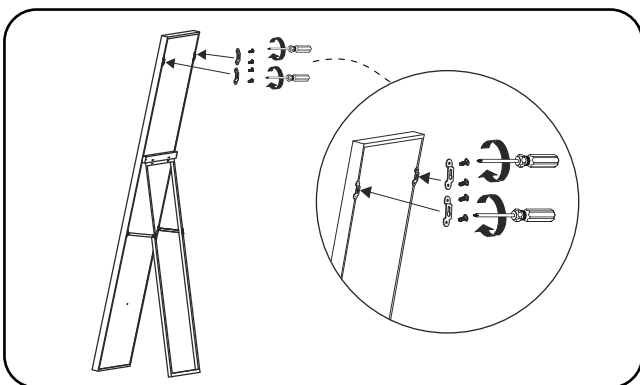

5. Mit dem schraubenzieher hängt man einen kran in die rahmen.

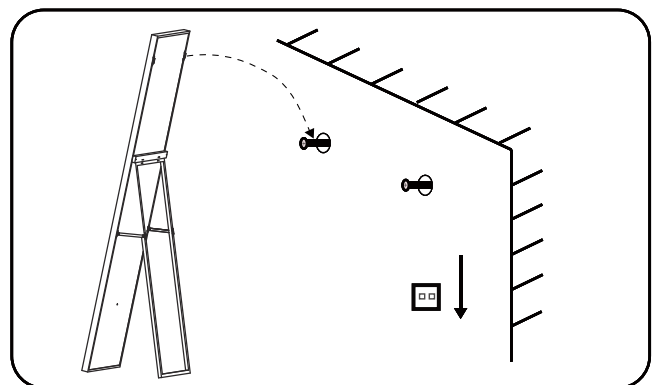

6. Spiegel an der Schraube aufhängen

BETRIEBSANLEITUNG



EIN/AUS-Taste



- Die Taste leuchtet blau, wenn sie mit dem Stromnetz verbunden ist.
 - Berühren Sie die Taste, um den Spiegel ein- bzw. auszuschalten
 - Zum Einstellen der Helligkeit die Taste gedrückt halten.
 - Bestätigen Sie die Einstellung, indem Sie den Finger entfernen, wenn Sie die gewünschte Farbe erreicht haben.
-

PFLEGEHINWEISE

Vor dem Reinigen den Spiegel ausschalten.

Zur Reinigung ein weiches und trockenes Tuch verwenden. Niemals Reinigungsmittel oder Scheuermittel verwenden. Lassen Sie keine Feuchtigkeit mit der Lampe in Kontakt kommen.

AVVERTENZE E ISTRUZIONI DI SICUREZZA

Prima dell'installazione, leggere attentamente il presente manuale di istruzioni. Durante l'installazione del prodotto, per assicurarsi che sia installato in modo sicuro e corretto, conservare il presente manuale per il riferimento futuro.

AVVERTENZA Rischio di incendio e Scosse elettriche

- Tutti gli accessori devono essere installati in conformità con le attuali norme di cablaggio IEE. In caso di dubbio, consultare un elettricista qualificato.
- Prima dell'installazione e della manutenzione, interrompere l'alimentazione elettrica sul circuito principale.
- Questo prodotto deve essere posizionato lontano da tende e tessuti. Non coprire mai lo specchio.
- Controllare regolarmente che il cavo, il trasformatore e tutte le altre parti non siano danneggiate. Se si riscontrano danni, non utilizzare il prodotto.

SICUREZZA DELL'INSTALLAZIONE

- Prima dell'installazione, assicurarsi che il prodotto non sia danneggiato o manchino delle parti. Maneggiare il prodotto con cura.
- Prima di forare, assicurarsi che non vi siano tubi o cavi nascosti nella parete.
- Indossare una protezione adeguata per gli occhi durante la foratura. Fare attenzione se si fora su superfici piastrellate, nel caso il trapano scivoli.



Attenzioni

Il nostro prodotto contiene una lampadina LED di classe di efficienza energetica <F>.

La sorgente luminosa di questo prodotto è costituita da diodi luminosi (LED) non sostituibili. Non disassemblare il prodotto visto che i diodi luminosi possono danneggiare gli occhi.

NOTA: Le importanti misure di sicurezza e le istruzioni riportate nel presente manuale non sono destinate a coprire tutte le possibili condizioni e situazioni che possono verificarsi. È necessario tenere presente che il buon senso, la cautela e l'attenzione sono fattori che non possono essere incorporati in nessun prodotto, ma che devono essere forniti dalla persona o dalle persone che si prendono cura del prodotto e lo utilizzano. Non installare questo prodotto in luoghi pericolosi.

BORSE PER ACCESSORI

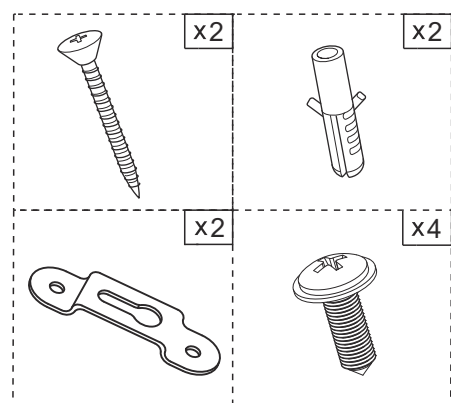

STRUMENTI NECESSARI



INSTALLAZIONE

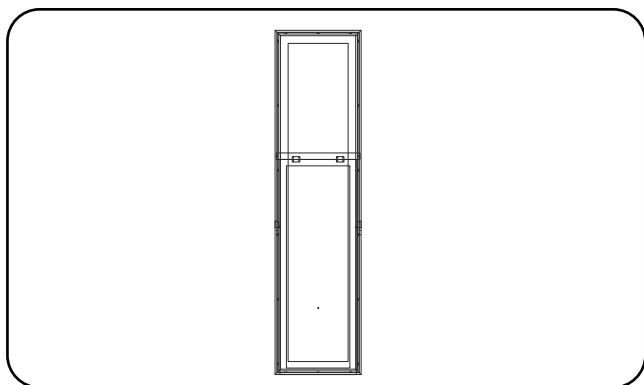

1. Misura la distanza del foro per appendere

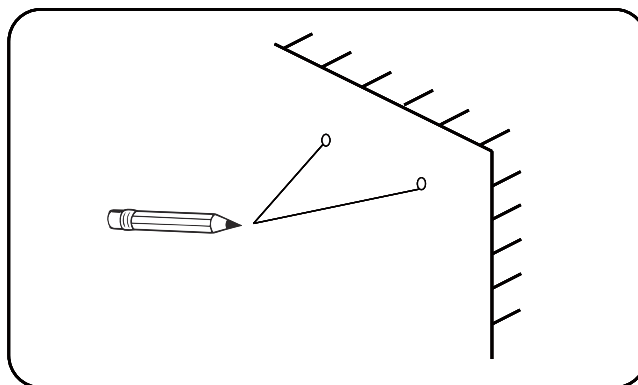

2. Contrassegnare la posizione del foro sul muro

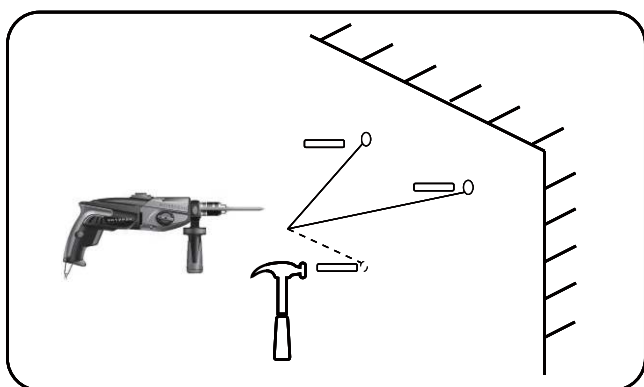

3. Praticare i fori e posizionare i tasselli di plastica adatti.

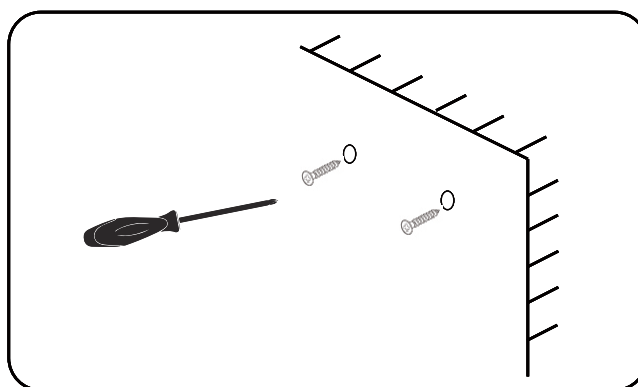

4. Disporre le viti sul muro, lasciando circa 3/8 di pollice fuori dal muro e assicurarsi che le viti siano stabili

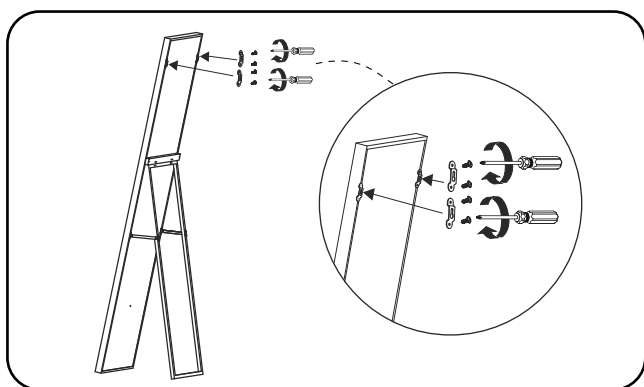

5. Usare un cacciavite per installare il gancio sul telaio.

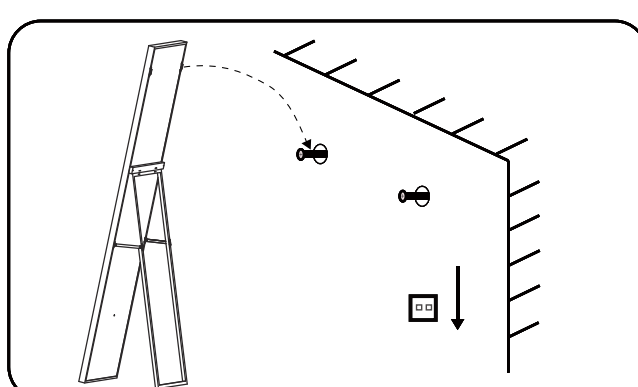

6. appendere lo specchio alla vite.

ISTRUZIONI PER IL FUNZIONAMENTO



Pulsante ON/OFF



- Il pulsante diventa blu quando è collegato all'alimentazione principale.
 - Toccare il pulsante per accendere/spegnere lo specchio.
 - Tenere premuto il pulsante per regolare la luminosità.
 - Confermare l'impostazione togliendo il dito quando si raggiunge il colore desiderato.
-

ISTRUZIONI PER LA CURA

Prima di procedere alla pulizia, assicurarsi che lo specchio sia spento.

Pulire con un panno morbido e asciutto. Non utilizzare mai detersivi o materiali abrasivi. Non lasciare che l'umidità entri in contatto con la lampada.

If you have any questions, please contact our customer care center.

US

Our contact details are below:

 001-877-644-9366

 customerservice@aosom.com

Imported by Aosom LLC

27150 SW Kinsman Rd Wilsonville, OR 97070 USA

MADE IN CHINA

Si tiene alguna pregunta, comuníquese con nuestro Centro de Atención al Cliente.

ES

Nuestros datos de contacto son los siguientes:

 0034-931294512

 atencioncliente@aosom.es

IMPORTADOR:

SPANISH AOSOM, S.L.

C/ ROC GROS, Nº 15. 08550, ELS HOSTALETES DE BALENYÀ, SPAIN.

B66295775

WWW.AOSOM.ES

HECHO EN CHINA

If you have any questions, please contact our customer care center.

CA

Our contact details are below:

 416-792-6088

 customerservice@aosom.ca

Imported by Aosom Canada Inc.

7270 Woodbine Avenue, Unit 307, Markham,

Ontario Canada

L3R 4B9

MADE IN CHINA

Si vous avez la moindre question, veuillez contacter notre centre d'assistance à la clientèle.

Nos coordonnées sont les suivantes:

 416-792-6088

 customerservice@aosom.ca

Importé par Aosom Canada Inc.

7270 Woodbine Avenue, unité 307,

Markham, Ontario Canada

L3R 4B9

FABRIQUÉ EN CHINE

Se tiver alguma dúvida, por favor contacte o nosso Centro de Atendimento ao Cliente.

PT

Os nossos dados de contacto são os seguintes:

 0034-931294512 (SEG-SEX DAS 7:30H ÀS 16:30H)

 info@aosom.pt.

IMPORTADOR:

SPANISH AOSOM, S.L

C.ROC GROS N.15, 08550. ELS HOSTALETES DE BALENYÀ

WWW.AOSOM.PT

Wenn Sie Fragen haben, wenden Sie sich bitte an unser Kundendienstzentrum.

DE

Unsere Kontaktdaten stehen unten:

 0049-0(40)-88307530  service@aosom.de

ADRESSE DES IMPORTEUR:

MH Handel GmbH

Wendenstraße 309

D-20537 Hamburg

Germany

IN CHINA HERGESTELLT

If you have any questions, please contact our customer care center.

UK

Our contact details are below:

 0044-800-240-4004

 enquiries@mhstar.co.uk

IMPORTER ADDRESS:

MH STAR UK LTD

Unit 27, Perivale Park,

Horsenden lane South

Perivale, UB6 7RH

MADE IN CHINA

In caso di dubbio, si prega di contattare il nostro centro assistenza clienti.

IT

I nostri dettagli di contatto sono di seguito:

 0039-0249471447  clienti@aosom.it

IMPORTATO DA:

AOSOM Italy srl

Centro Direzionale Milanofiori

Strada 1 Palazzo F1

20057 Assago (MI)

P.I.: 08567220960

FATTO IN CINA

Si vous avez la moindre question, veuillez contacter notre centre d'assistance à la clientèle.

FR

Nos coordonnées sont les suivantes:  0033-1-84166106  aosom@mhfrance.fr

Importé par: MH France 2, rue Maurice Hartmann 92130 Issy-les-Moulineaux

Fabriqué en Chine

France



FR

**DONNEZ
OU
RECYCLEZ**



OU



OU



ASSOCIATION LIVRAISON DÉCHÈTERIE

Adresses sur quefairedemesdechets.fr

