

# AIYAPLAY

## CHILDREN'S ELECTRONIC TOY UTV

IN240600276V01\_UK\_370-355V70



### **WARNING:**

**Must be assembled by an adult.**

- Suitable for 3+ Years
- Maximum user weight: 50 kg

# OWNERS MANUAL

with Assembly Instructions

**Read and understand this entire manual before using!**

Please keep this manual for future reference as it contains important information. Before first time use, charge the battery for at least 4-6 hours, but no more than 10 hours.

On the purchase of your new Ride-On.

This ride-on car will provide your child with many miles of riding of enjoyment. To help assure you and your rider a safe ride we ask you to please read this manual carefully, and keep it for future reference.

Follow the recommendations in this manual, they are designed to improve the safety and operation of your ride-on car and its rider.

## Specification

	<b>4WD</b>
<b>Battery</b>	24V7AH
<b>Charger</b>	24V1000mA
<b>input</b>	Depend on local voltage
<b>Motor</b>	390-15000*4
<b>Steering Motor</b>	390-4000*1

<b>Suitable age:</b>	3+ Years
<b>Charge time:</b>	8~12 hours
<b>Load capacity:</b>	Under 50 kg
<b>Size of car:</b>	117×72×67 CM
<b>Speed:</b>	3-7 km/h



## BATTERY INFORMATION

- Non-rechargeable batteries are not to be recharged.
- Rechargeable batteries are to be removed from the toy before being charged.
- Rechargeable batteries are only to be charged under adult supervision.
- Different types of batteries or new and used batteries are not to be mixed.
- Batteries are to be inserted with the correct polarity.
- Exhausted batteries are to be removed from the toy.
- The supply terminals are not to be short-circuited.

**WARNING:**

- **CHOKING HAZARD!** Not suitable for children under 36 months.
- Must be assembled by an adult.
- To reduce the risk of injury, adult supervision is required.
- Never use in roadways, near motor vehicles, on or near steep inclines or steps, swimming pools or other bodies of water; always wear shoes, and never allow more than 1 rider.
- Power supply or battery charger used with the electric toy shall be regularly examined for damage to the supply cord, plug, enclosure or other parts, and in the event of damage, it shall not be used until the damage has been repaired.
- Use only battery(ies) and charger specified by the manufacturer.
- The battery on the vehicle is not replaceable.
- This toy should be used with caution since skill is required to avoid falls or collisions causing injury to the user or third parties.
- Protective equipment should be worn.
- Always wear shoes, always sit on the seat.
- Not to be used in traffic.
- This toy is unsuitable for children under 36 months due to its maximum speed; Maximum user weight is 50 kg.
- This toy has no brake.

**Rules for Safe Riding**

- Keep Children within Safe Riding Areas.
- Use the toy only on flat surfaces. Such as inside your house, garden or playground.
- Never use in the dark. A child could encounter unexpected obstacles and have an accident. Operate the vehicle only in the daytime or a well-lit area.
- It is prohibited to change the circuit or add other electric parts
- Inspect wires and connections of the vehicle periodically.
- Do not let any child touch the wheels or be near them when the car is moving .
- This vehicle has adjustable play seat belts. Please instruct children how to tie the safety belt before using, guarantee the security.

**1** Vehicle body  
x1



**2** Front bumper  
x1



**3** Gear box  
**4WD** x4



**4** Driving wheel  
**4WD** x4



**7** Lock nut  
x6



**6** Ø12 washer  
**4WD** x4



**9** Spring  
x2



**8** Hubcap  
x4



**11** Front axle  
x1  
**4WD**



**10** #4x12 screw  
x8

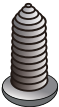

**13** Rear wheel carrier  
x1



**12** Rear axle  
x1



**15** M5x35 machine screw  
x1



**14** Steering wheel  
x1



**17** Seat back  
x1



**16** #5 nut  
x1



- 19** Front roll bar  
x1



- 18** Seat cushion  
x1



- 21** Roll bar linkage  
x1



- 20** Side roll bar  
x2  
left & right



- 23** Charger  
x1



- 22** Socket wrench  
x2

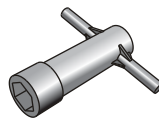

- 24** Remote controller  
(If equipped)  
x1



**Assembly tools required (not included):**  
**Screwdriver**



# Parts Diagram

HINT: Some parts shown are assembled on both sides of vehicle

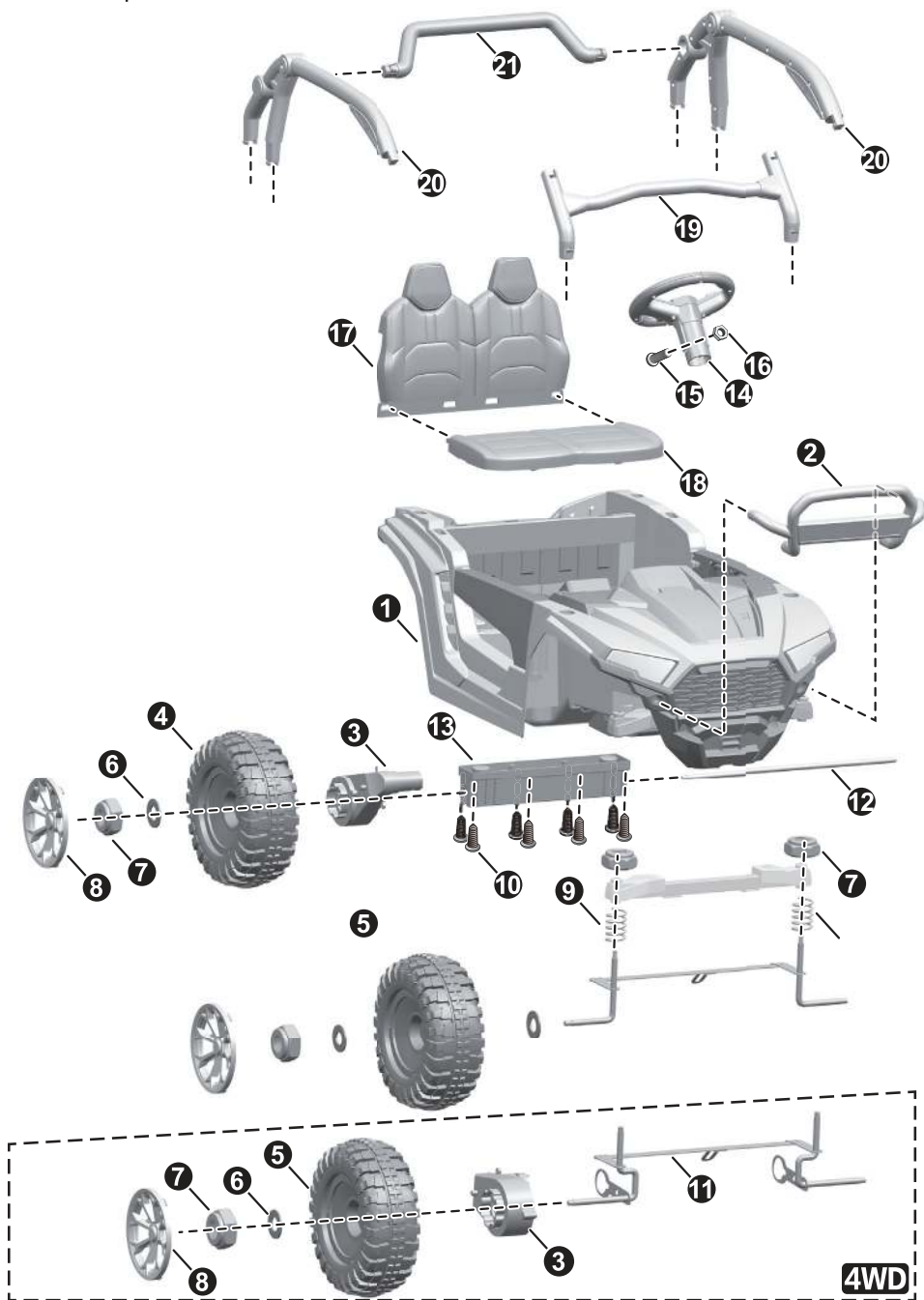

Front bottom View

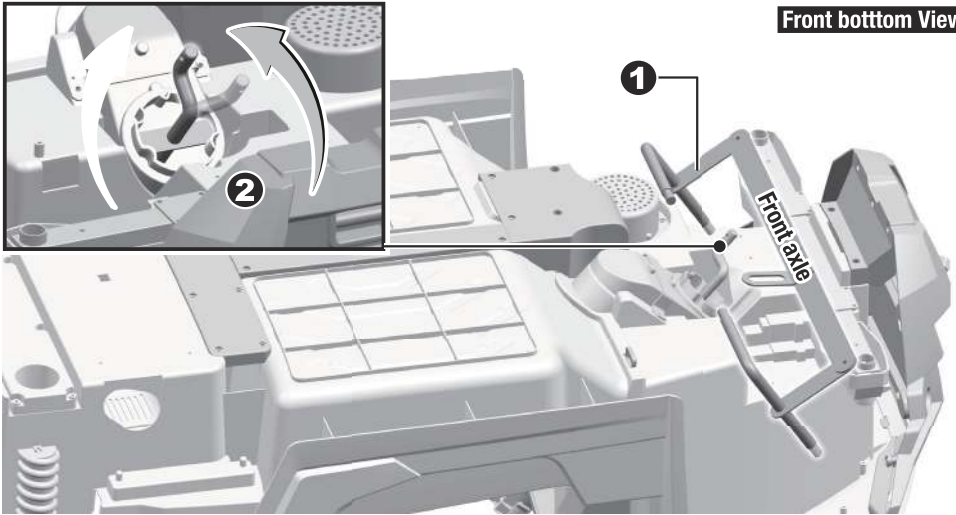

Turn the vehicle body upside down.

1. Cut off the the cable ties on the front end of vehicle body with scissors. And remove the front axle.
2. Rotate the bent end of the steering column to the correct position as shown.
- 3-4. Fit two shock springs to the front axle frame, fit the front axle to the front axle frame on the vehicle body.
5. Insert the bent end of the steering column into the hole in the front axle linkage.
6. Tighten a locknut to each end of the front axle with a socket wrench.

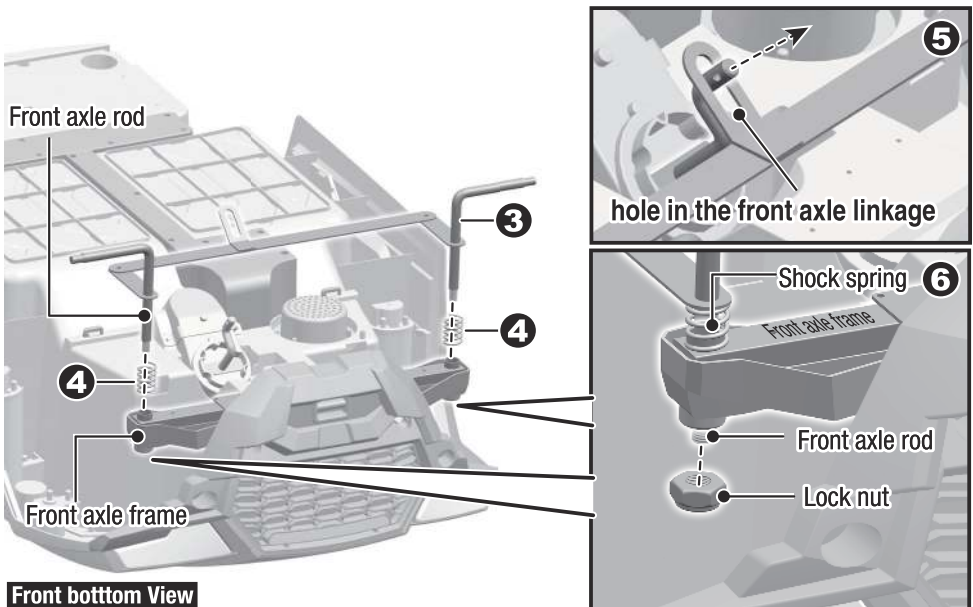

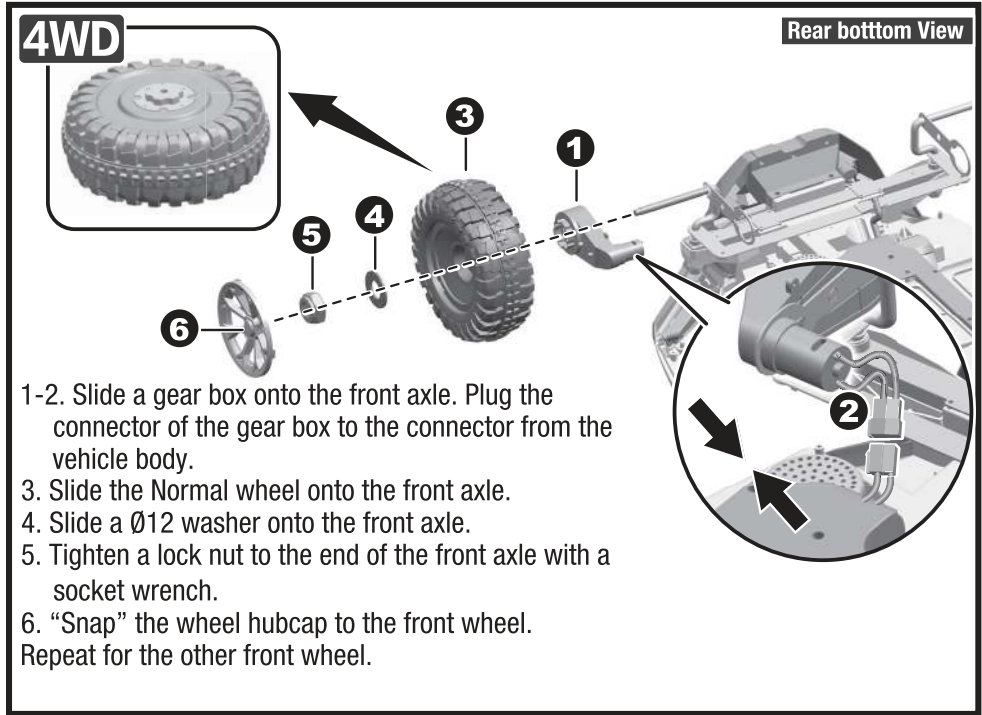



Rear botttom View

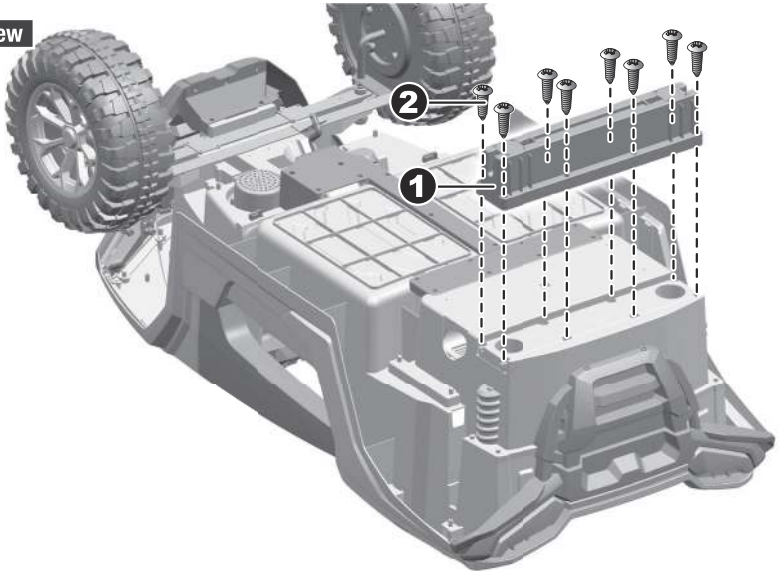

1. Fit the rear wheel house onto the vehicle body.
2. Insert eight  $\text{\O}4 \times 12$  screws and tighten with screwdriver.
3. Insert the rear axle through the hole in the rear axle carrier.

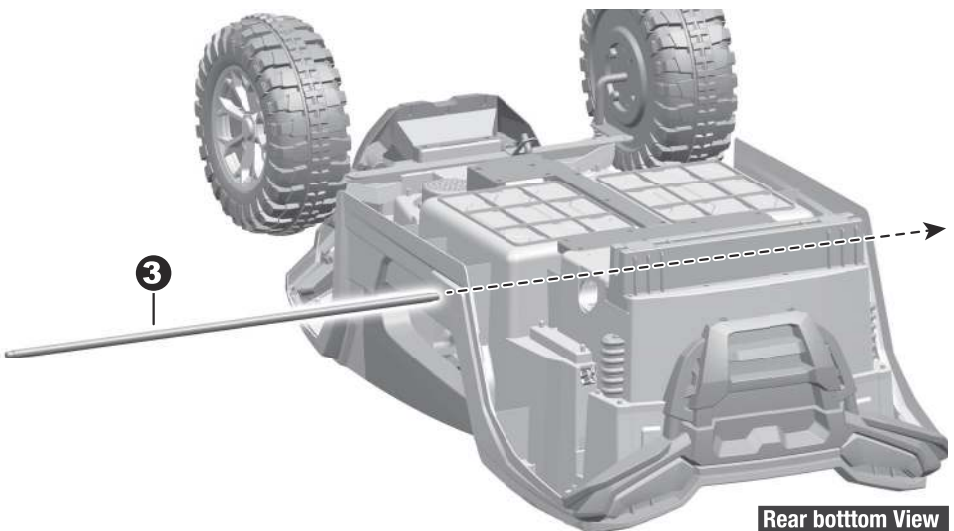

Rear botttom View

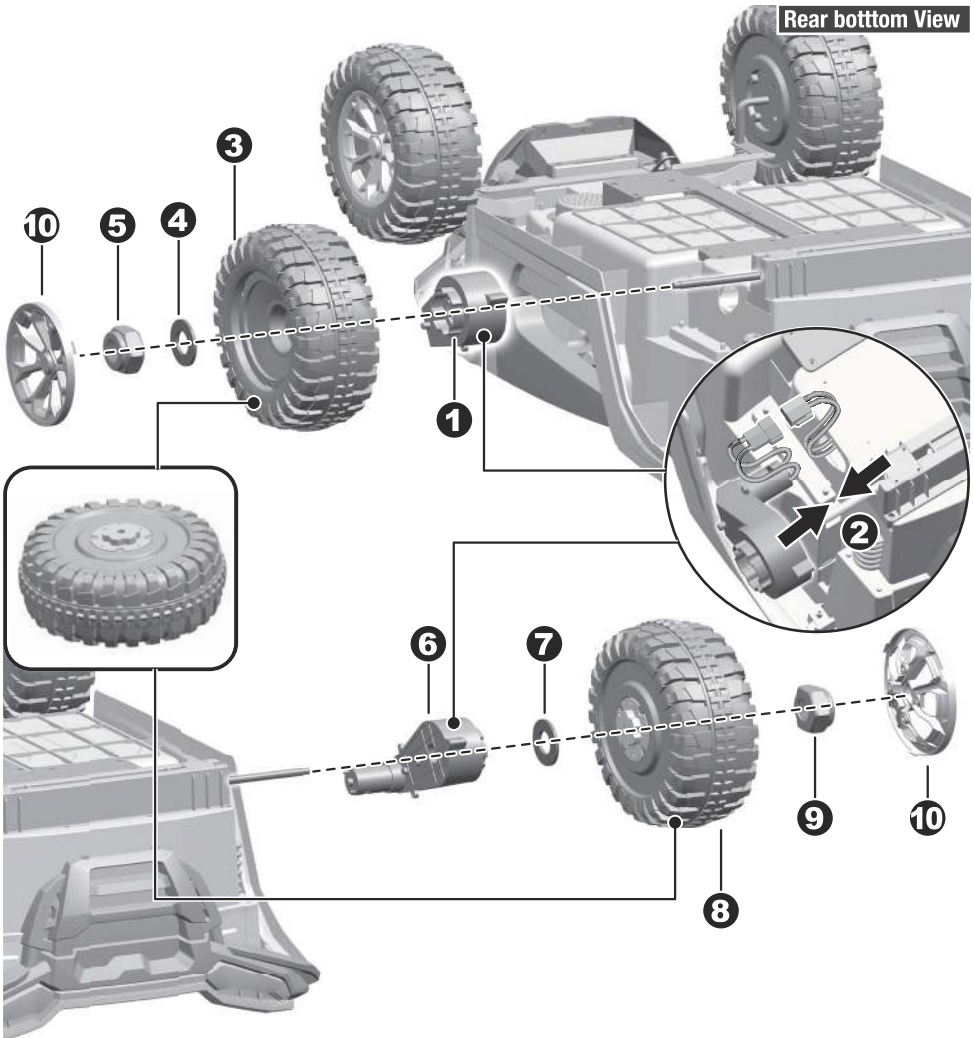

1. Slide a gear box on the rear axle, and ensure the motor on the gear box passes through the hole in the vehicle body.
2. Plug the connector on the gear box into the connector from the vehicle body.
3. Slide the driving wheel onto the rear axle. Ensure the wheel driver match up with the gear box.
4. Slide a  $\varnothing 12$  washer onto the front axle.
5. Tighten a lock nut to the end of the front axle with a socket wrench. DO NOT over tighten.
- 6-9. Repeat the above procedures to assemble the other rear wheel.
10. "Snap" the hubcaps to the wheels.

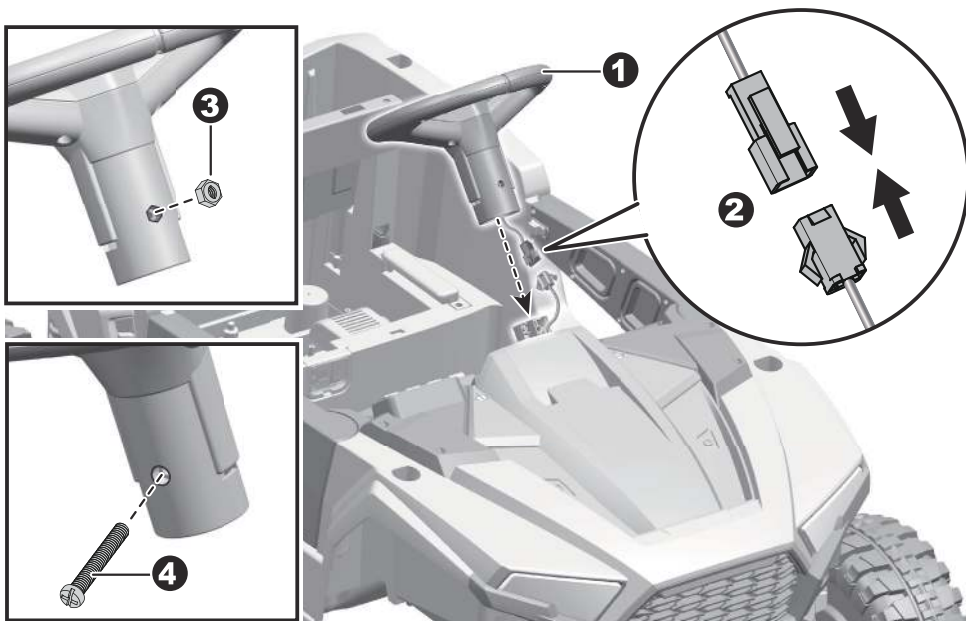

Turn the vehicle body upright.

1. Plug the sound unit connector on the steering wheel into the connector on the vehicle body.
2. Fit the steering wheel to the end of the steering column.
3. Insert the #5 nut into the slot at right side of the steering wheel.
4. Line up the holes on the steering wheel with the holes on the steering column, insert the M5x45 machine screw.
5. Insert the tabs on the front bumper into the grooves in the vehicle body, push until you hear it “click” into place.



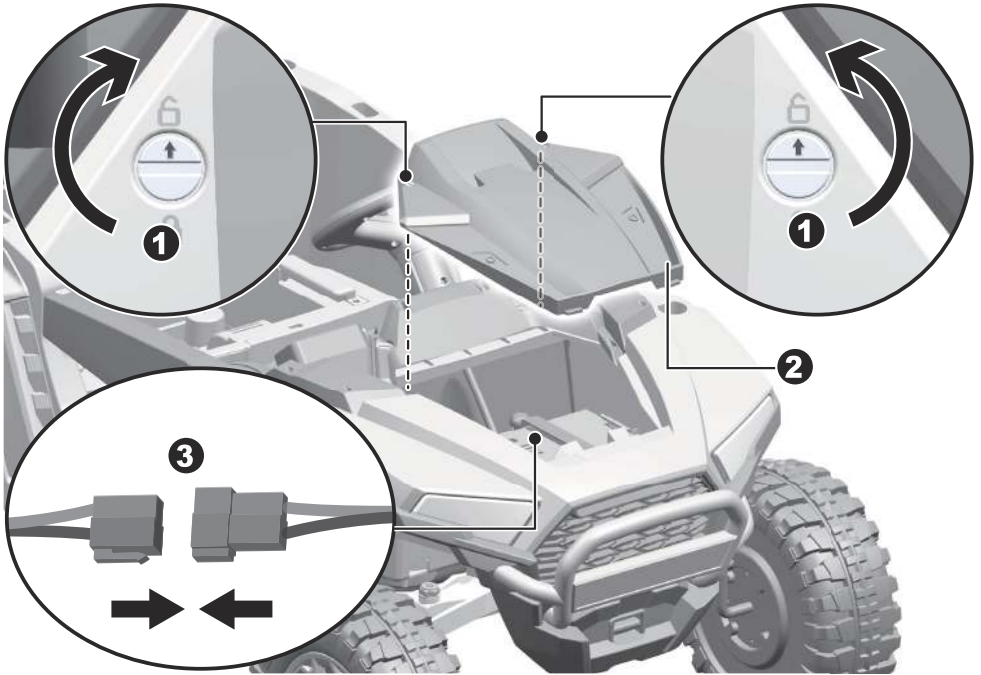

Tabs on seat back

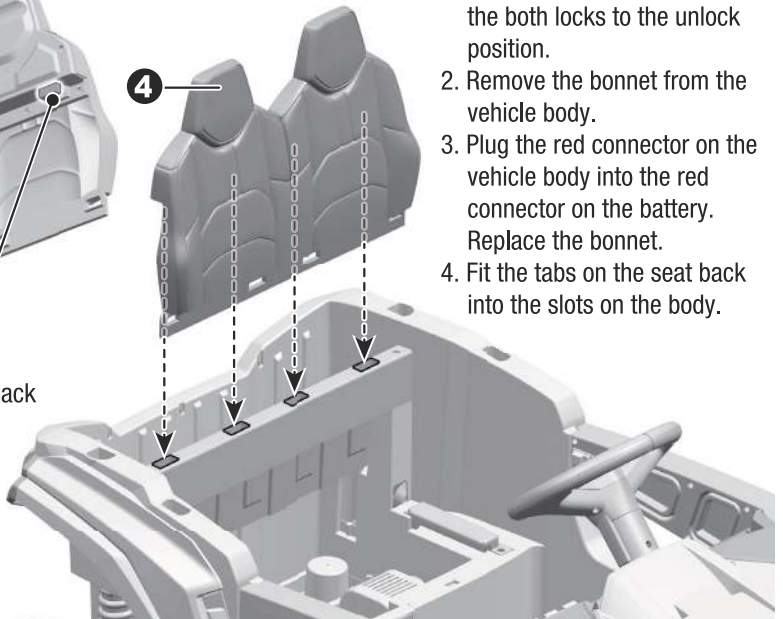

1. Using a slotted screwdriver (not included) or coin to turn the both locks to the unlock position.
2. Remove the bonnet from the vehicle body.
3. Plug the red connector on the vehicle body into the red connector on the battery. Replace the bonnet.
4. Fit the tabs on the seat back into the slots on the body.

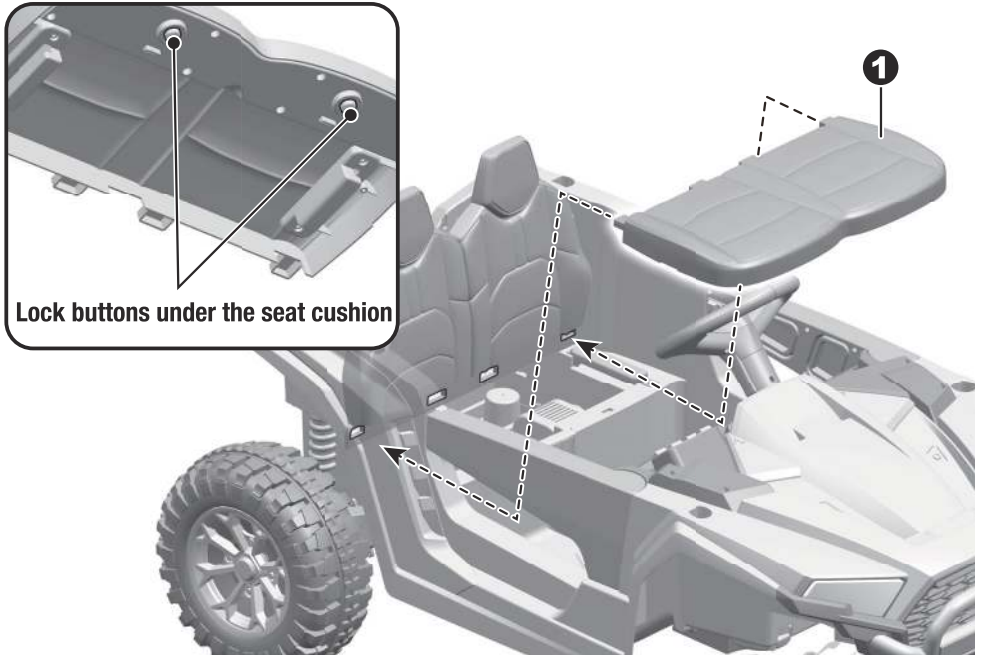

1. Press the two lock buttons at the bottom of the seat cushion to fit it to the body.
2. Fit the front roll bar to vehicle body.



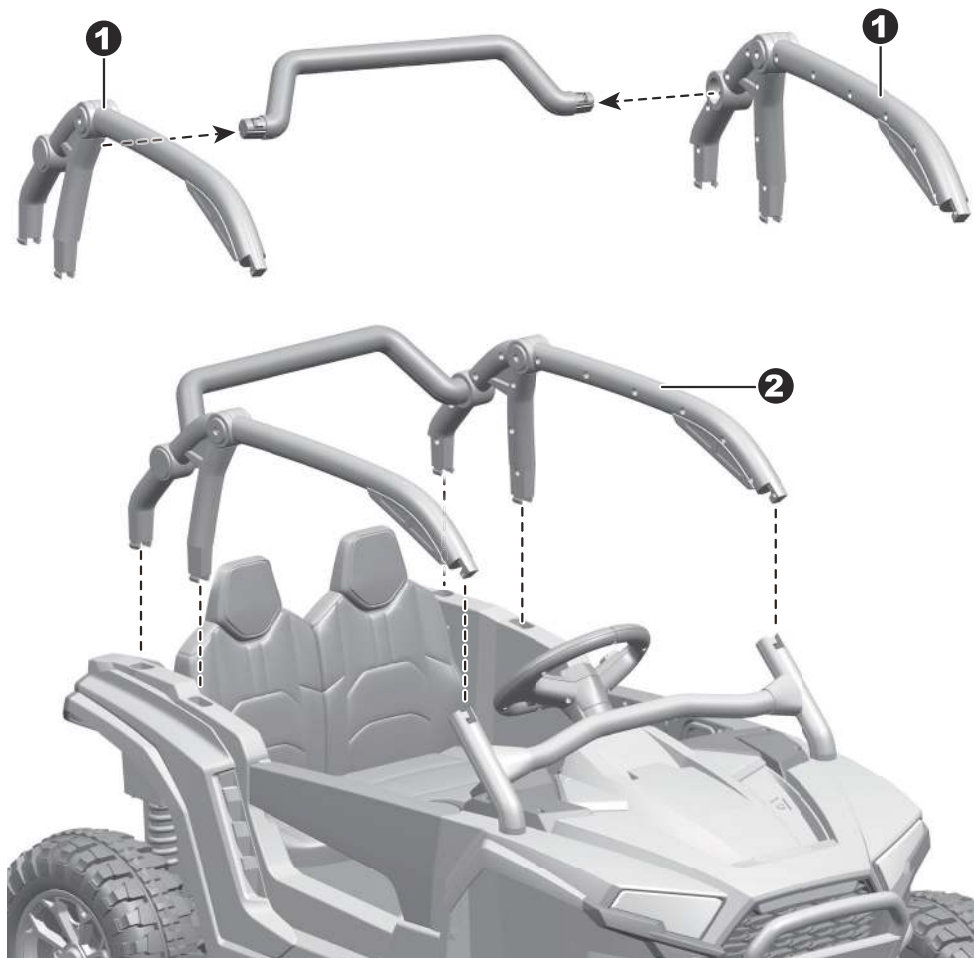

1. Fit the two side roll bars to the roll bar linkage.
2. Fit the roll bar assembly to the vehicle body.

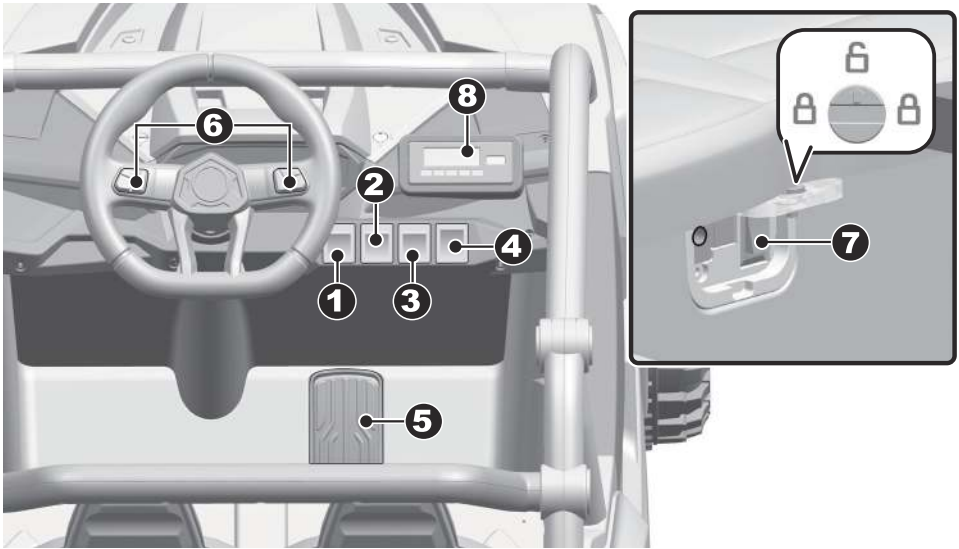

**1. Power switch:** Turns the product on and off.

**2. Forward/Reverse switch:**

Changes the direction that product moves from forward to reverse.

- To move the product forward, shift the lever to top position.
- To move the product backward, shift the lever to down position.

**3. High/Low speed switch:**

Operates the product to move forward in high or low speed.

**4. Light switch:** Turns lights on and off.

**5. Accelerator pedal:**

- To move the product, press the pedal down.
- To brake or slow down, release pressure from the pedal.

**6. Sound buttons:** Press for sound or horn playing.

**7. RC-Manual switch (if equipped, this switch is under the seat, please turn the knob to the unlocked position and open the protective cover. ):**

- Rock the switch to the “RC” position, and the product is only allowed to be controlled by the remote controller.
- Rock the switch to the manual position to allow manual operation of the product.

**⚠ WARNING!**

- Always stop vehicle when changing the speed or direction to avoid damage the gears and motor.
- The protective cover must be opened by an adult.

### 8. Audio Player:

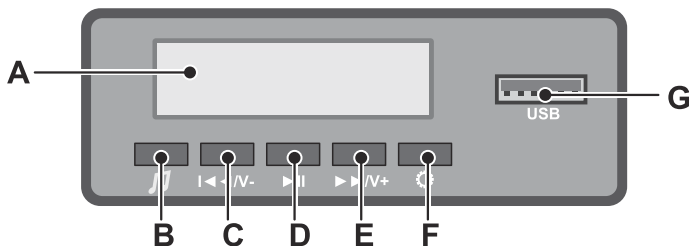

**A. Display Screen:** When the product is stopped, it displays the remaining battery level. If the displayed value falls below 12 (for 12V products) or 24 (for 24V products), please recharge the battery.

**B. Music Button**

**C. Previous Track / Volume Down Button**

**D. Play/Pause Button**

**E. Next Track / Volume Up Button**

**F. Audio Source button**

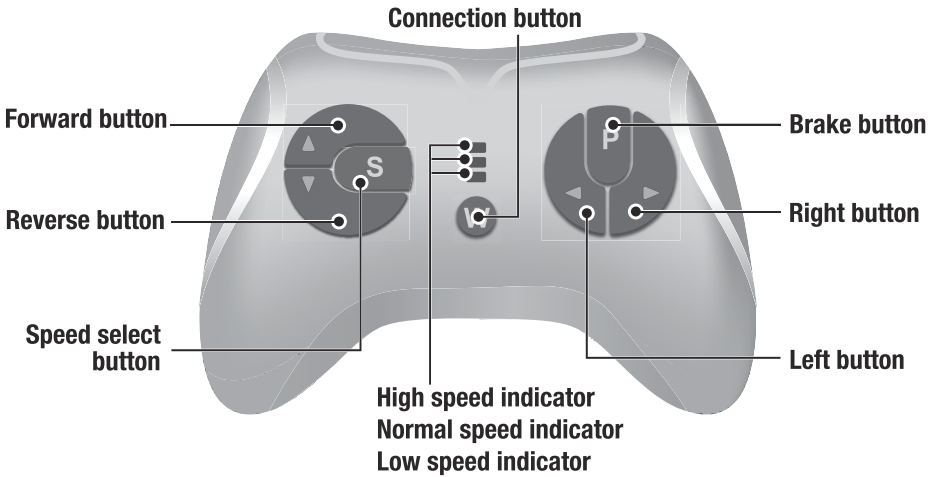

**WARNING:****ADULT OPERATING REQUIRED!**

## Insert the batteries of controller

Lift the battery compartment door on the back of the controller and insert two AAA(LR03) batteries.

**HINT: Batteries not included. Refer to the Battery Information on the page 1.**

### 1. Build connection

Press the Connection button for 2 seconds, the status indicator flashes, then turn on the power switch located on the the vehicle dash, when the status indicator turns off about 2 seconds and turns into long bright, means the connection successful. If the status indicator makes no response, means the connection failed. Replace the batteries and try again.

### 2. Brake button

Press the button to stop the vehicle, press it again to release the brake.

### 3. Speed select button

The switch operates the vehicle to move in low, normal or high speed.

**HINT:** This switch won't work while your vehicle moves reverse.

## NOTE:

- Leave the remote controller idling for about 10 seconds, it will shut down automatically.
- Rebuild connection when you replace the batteries of the remote controller.

**WARNING!**

**ONLY AN ADULT CAN CHARGE AND RECHARGE THE BATTERY!**

**WARNING!**

This product with **Charging Protection**: when charging, all functions will be cut off!  
Only an adult can charge and recharge the battery!

- The POWER SWITCH must be turned in OFF position when charging.
- Before the first use, you should charge the battery for 4-6 hours. Do not recharge the battery for more than 10 hours to avoid overheating the charger.
- When the vehicle begins to run slowly, recharge the battery.
- After each use or once a month minimum recharge time as 8 to 12 hours, less than 20 hours at most.
- Use the only rechargeable battery and charger supplied with your vehicle. NEVER substitute the battery or the charger with another brand. Using another battery or charger may cause a fire or explosion.
- Do not use the battery or charger for any other product.

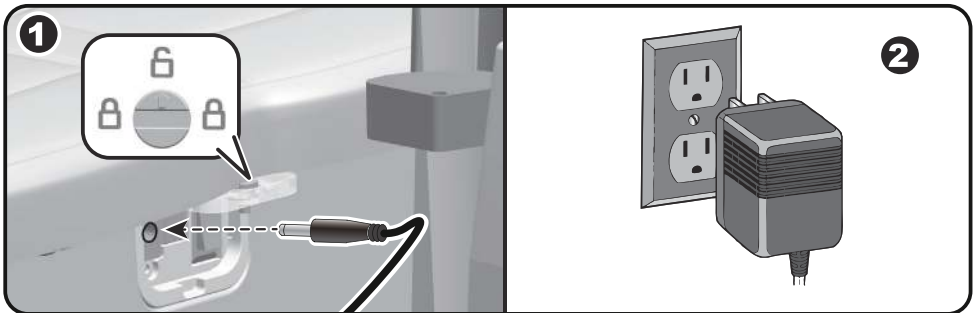

**The input socket is below the seat. Please turn the knob to the unlocked position and open the protective cover**

1. Plug the charger port into the input socket.
2. Plug the charger plug into a wall outlet. The battery will begin charging.

Problem	Possible Cause	Solution
Vehicle does not run	Battery low on power	Recharge battery.
	Thermal fuse has tripped	Reset fuse, see <Fuse>
	Battery connector or wires are loose	Check that the battery connectors are firmly plugged into each other. If wires are loose around the motor <b>contact your distributor please.</b>
	Battery is dead	Replace battery, <b>contact your distributor please.</b>
	Electrical system is damaged	<b>Contact your distributor please.</b>
	Motor is damaged	<b>Contact your distributor please.</b>
Vehicle does not run very long	Battery is under charged	Check that the battery connectors are firmly plugged into each other when recharging
	Battery is old	Replace battery, <b>contact your distributor please.</b>
Vehicle runs sluggishly	Battery low on power	Recharge battery, <b>contact your distributor please.</b>
	Battery is old	Replace battery, <b>contact your distributor please.</b>
	Vehicle is overload	Reduce weight on vehicle.
	Vehicle is being used in harsh conditions	Avoid using vehicle in harsh conditions ,see <Safety>.
Vehicle needs a push to go forward	Poor contact of wires or Connectors	Check that the battery connectors are firmly plugged into each other. If wires are loose around the motor, <b>contact your distributor please.</b>
	“Dead Spot” on motor	A dead spot means the electric power is not being delivered to the terminal connection and the vehicle needs repair. <b>Contact your distributor please.</b>
Difficult shifting from forward to reverse or vice-versa	Attempting to shift while the vehicle is motion	Completely stop the vehicle and shift, see <Use Your New Vehicle>
Loud grinding or clicking noises coming from motor or gear box	Motor or gears are damaged	<b>Contact your distributor please.</b>
Battery will not recharge	Battery connector or adapter connector is loose	Check that the battery connectors are firmly plugged into each other.
	Charger not plugged in	Check that the battery charger is plugged into a working wall outlet.
	Charger is not working	<b>Contact your distributor please.</b>
Charger feels warm when recharging	This is normal and not a cause for concern	

Completely read through this manual and the troubleshooting guide table before calling. If you still need help resolving the problem **Contact your distributor please.**

- It is parents' responsibility to check main parts of the toy before using, must regularly examine for potential hazard, such as the battery, charge, cable or cord, plug, screws are fastening enclosure of other parts and that in the event of such damage, the toy must not be used until that damage had been properly removed.
- Make sure the plastic parts of the vehicle are not cracked or broken.
- Occasionally use a lightweight oil to lubricate moving parts such as wheels.
- Park the vehicle indoors or cover it with a tarp to protect it from wet weather.
- Keep the vehicle away from sources of heat, such as stoves and heaters. Plastic parts may melt.
- Recharge the battery after each use. Only an adult can handle the battery. Recharge the battery at least once a month when the vehicle Raider is not being used.
- Do not wash the vehicle with a hose. Do not wash the vehicle with soap and water. Do not drive the vehicle in rainy or snowy weather. Water will damage the motor, electric system and battery.
- Clean the vehicle with a soft, dry cloth. To restore shine to plastic parts, use a non-wax furniture polish. Do not use car wax. Do not use abrasive cleaners.
- Do not drive the vehicle in loose dirt, sand or fine gravel which could damage the moving parts, motors or the electric system.
- When not using, all the electrical source should be turn off. Turn off the power switch and disconnect the battery connection.

The battery features a thermal fuse with a reset fuse that will automatically trip and cut all power to the vehicle if the motor, electric system or battery is overloaded. The fuse will reset and power will be restored after the unit is turned OFF for 20 seconds and then turned ON again. If the thermal fuse trips repeatedly during normal use, the vehicle may need repair. Contact your distributor please.

To avoid losing power, follow these guidelines:

- Do not overload the vehicle.
- Do not tow anything behind the vehicle.
- Do not drive up steep slopes.
- Do not drive into fixed objects, which may cause the wheels to spin, causing the motor to overheat.
- Do not drive in very hot weather, components may overheat.
- Do not allow water or other liquids to come in contact with the battery or other electric components.
- Do not tamper with the electric system. Doing so may create a short, causing the fuse to trip.

Our products are suitable for ASTM F963; GB6675; EN71 and EN62115 standard.

## Disposal Of Battery



- Your sealed lead-acid battery must be recycled or disposed of in an environmentally sound manner.
- Do not dispose of your lead-acid battery in a fire. The battery may explode or leak.
- Do not dispose of a lead-acid battery in your regular, household trash. The incineration, land filling or mixing of sealed lead-acid batteries with household trash is prohibited by law.

If you have any questions, please contact our customer care center.  
Our contact details are below:



0044-800-240-4004



enquiries@mhstar.co.uk

IMPORTER ADDRESS:  
MH STAR UK LTD  
Unit 27, Perivale Park,  
Horsenden Lane South  
Perivale, UB6 7RH  
MADE IN CHINA