



INade062V01_UK

A91-082

Sit up bench

OWNER'S MANUAL

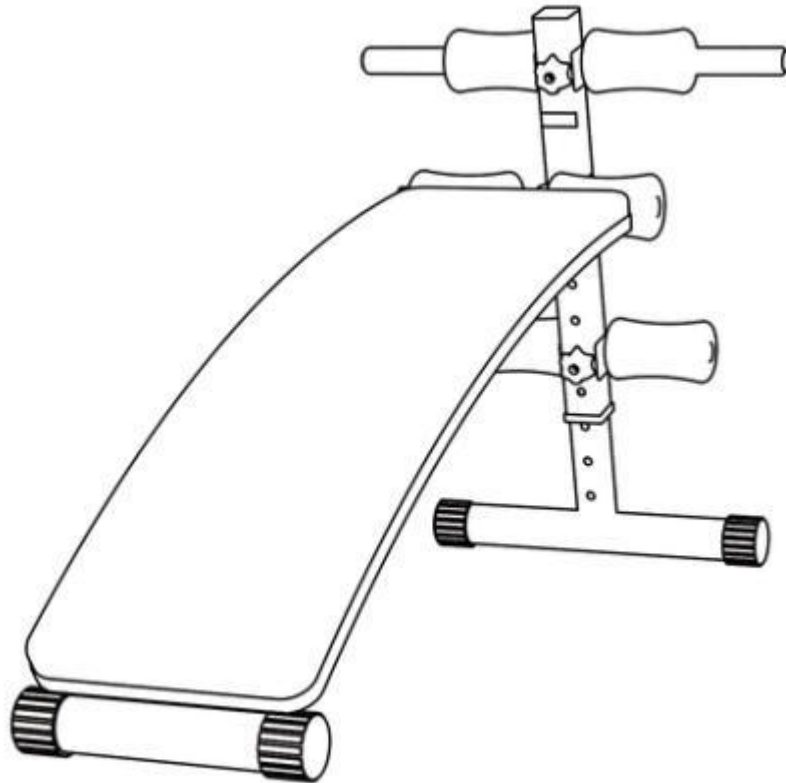

IMPORTANT, RETAIN FOR FUTURE REFERENCE: READ CAREFULLY

ASSEMBLY & INSTRUCTION MANUAL

PLEASE KEEP THIS MANUAL IN A SAFE PLACE FOR REFERENC

1. It is important to read this entire manual before assembling and using the equipment. Safe and effective use can only be achieved if the equipment is assembled, maintained and used properly. It is your responsibility to ensure that all users of the equipment are informed of all warnings and precautions.
2. Before starting any exercise program you should consult your doctor to determine if you have any medical or physical conditions that could put your health and safety at risk, or prevent you from using the equipment properly. Your doctor's advice is essential if you are taking medication that affects your heartrate, blood pressure or cholesterol level.
3. Be aware of your body's signals. Incorrect or excessive exercise can damage your health. Stop exercising if you experience any of the following symptoms: pain, tightness in your chest, irregular heartbeat, extreme shortness of breath, lightheadedness, dizziness or feelings of nausea. You should consult your doctor before continuing with your exercise program. If you do experience any of these conditions.
4. Keep children and pets away from the equipment. The equipment is designed for adult use only.
5. Use the equipment on a solid, flat level surface with a protective cover for your floor or carpet. The equipment should have at least 0.5 meters of free space all around to ensure the safety
6. Check all the nuts and bolts are securely tightened before using the equipment.
7. The safety of the equipment can only be maintained if it is regularly examined.
8. Always use the equipment as indicated. If you find any defective components while assembling or checking the equipment, or if you hear any unusual noises coming from the equipment during exercising, stop using the equipment immediately and don't use the equipment until the problem has been repaired.
9. Wear suitable clothing while using the equipment. Avoid wearing loose clothing that may get caught in the equipment.
10. The equipment is not suitable for therapeutic use.
12. You must take care of yourself when lifting and moving the equipment so as not to injure your back. Always use proper lifting technique and seek assistance if necessary.

Using your sit up bench provide you with several benefits, it will improve your physical fitness, tone muscle and in conjunction with calorie controlled diet help you lose weight.

1.The Warm Up Phase

This stage helps get the blood flowing around the body and the muscles working properly. It will also reduce the risk of cramp and muscle injury. It is advisable to do a few stretching exercises as shown below. Each stretch should be held for approximately 30 seconds, do not force or jerk your muscles into a stretch - if it hurts, **STOP**.

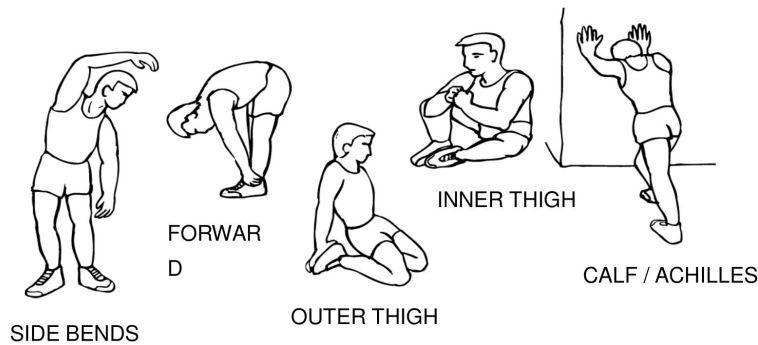

2.The Exercise Phase

This is the stage where you put the effort in. After regular use , the muscles in your legs will become Stronger. Work to your but it is very important to maintain a steady tempo throughout. The rate of work should be sufficient to raise your heart beat into the target zone shown on the graph below.

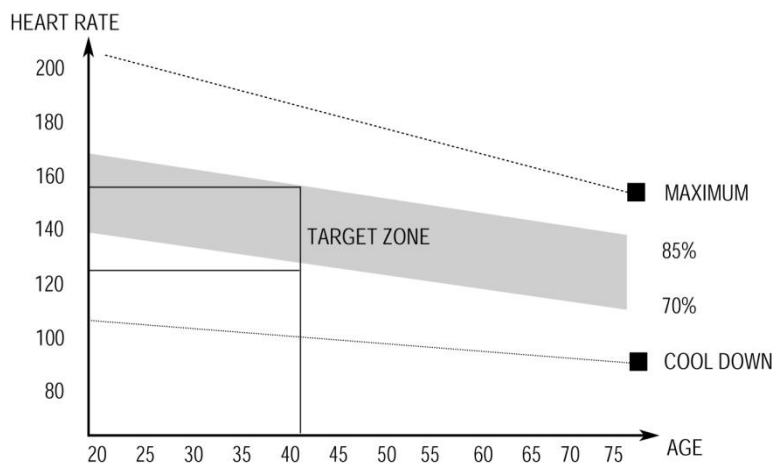

This stage should last for a minimum of 12 minutes though most people start at about 15-20 minutes.

3. The Cool Down Phase

As you get fitter you may need to train longer and harder. It is advisable to train at least three times a week, and if possible space your workouts evenly throughout the week.

Weight loss

The important factor here is the amount of effort you put in. The harder and longer you work the more calories you will burn. Effectively this is the same as if you were training to improve your fitness, the difference is the goal.

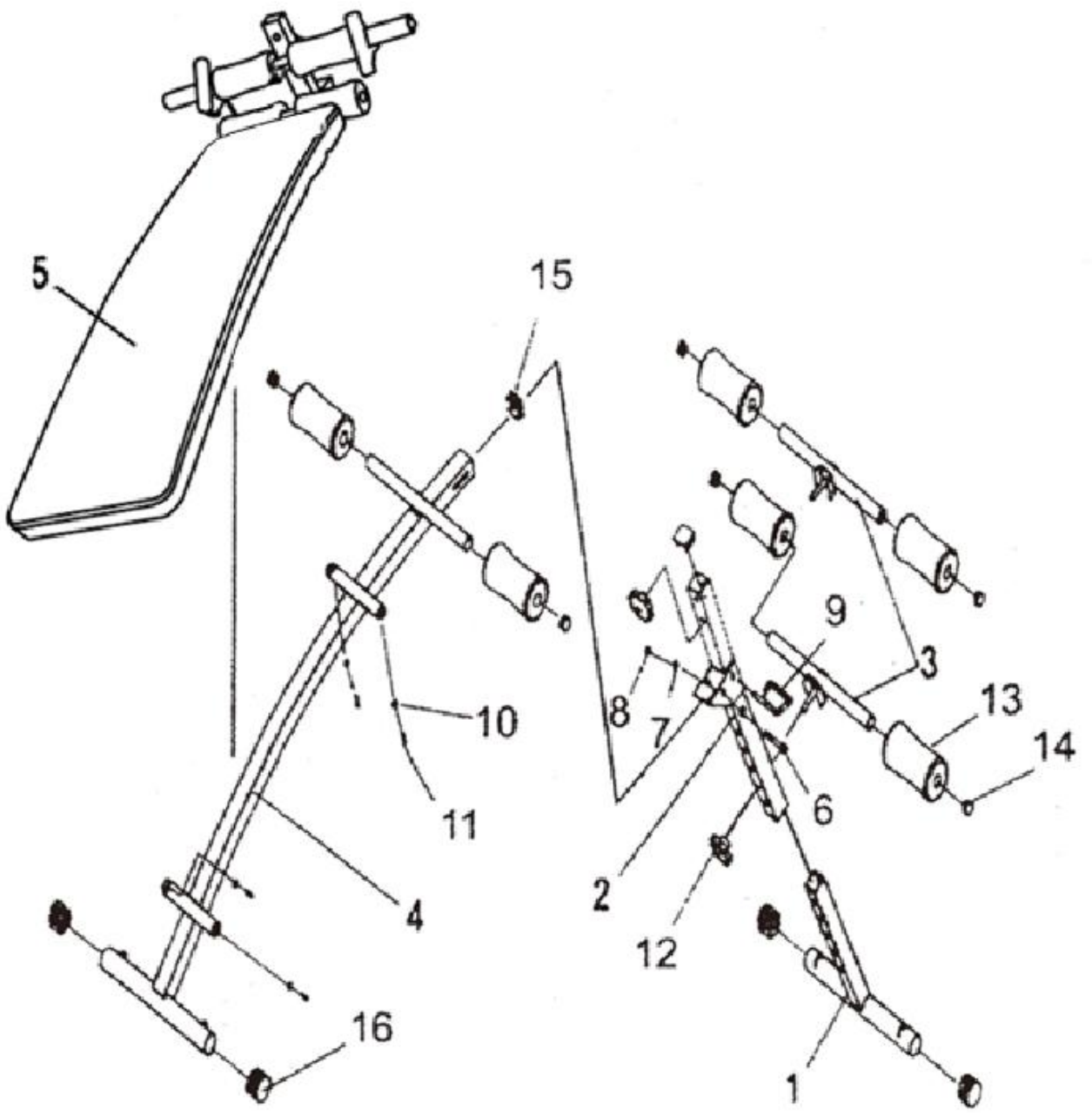

PART

PART No.	DESCRIPTION	QTY
1	Fount leg	1
2	Upper Support Frame	1
3	Cushion Holder	2
4	Main Frame	1
5	Back Cushion	1
6	Hexagonal Bolt(M8-60mm)	1
7	Washer(M8)	2
8	Nut(M8)	1
9	Safety-Hook	1
10	Washer(M6)	4
11	Screw(M6*50MM)	4
12	Knob nut	2
13	Circular Foam Grip(Φ 73* Φ 23* Φ 40mm)	6
14	End plug(Φ 25.4)	6
15	Square cap(38*38mm)	2
16	Round End cap(Φ 38)	1

Step 1

Insert the front leg (1) to the upper support frame(2)

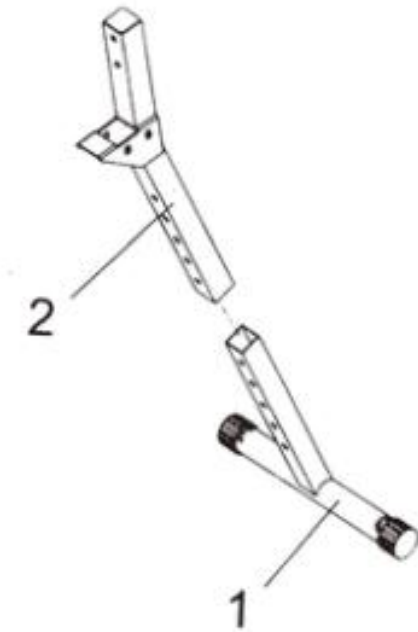

Step 2

Attach the front leg (1) and cushion, Holder (3) by one knob Nut (12) the correct height for the Back cushion can be adjust after bench is fully assemble

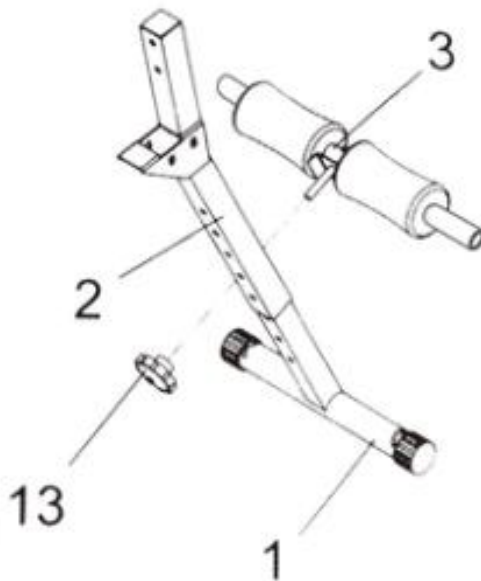

Step 3

Attache the cushion holder (3) to the upper support frame (2) using the knob Nut(12)

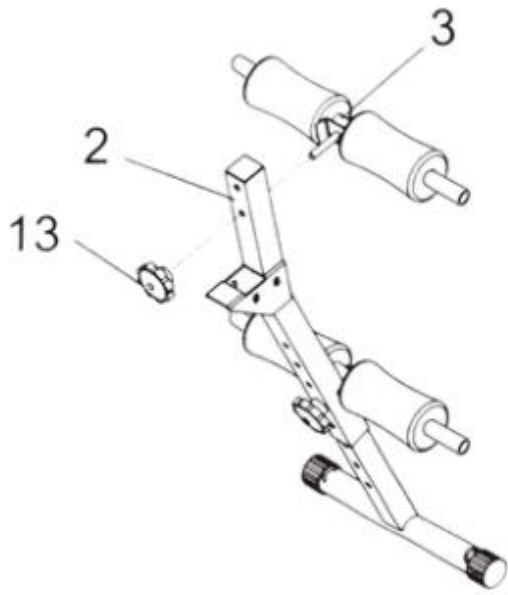

Step 4

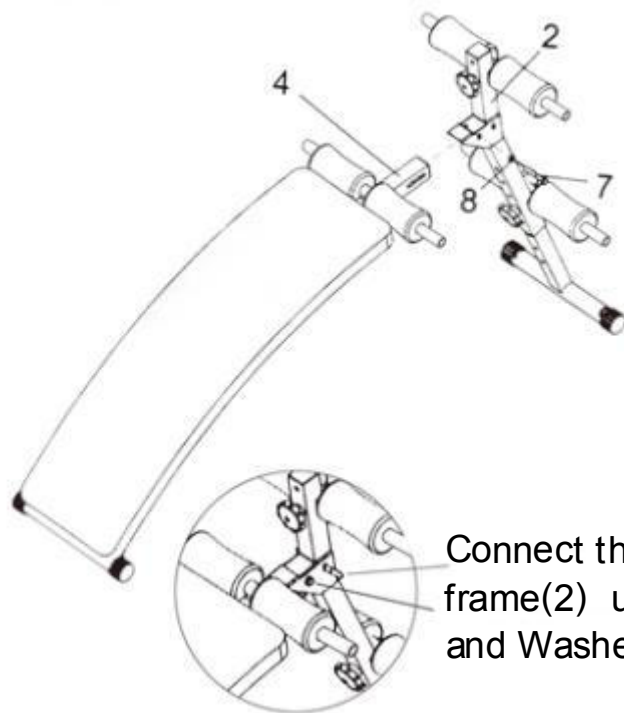

Connect the Main frame(2)to the upper Support frame(2) using one Hexagonal bolt(6).Nut(8) and Washer (7),the insert Safety Hock(9)

