



Pull-up Lifter

Tip: Read the instruction manual carefully before use and store it properly.

Thank you for purchasing this product. Please read these instructions carefully for proper use.

Safety precautions

Warning













- Do not use after illness, overfatigue or drinking alcohol.
- Child users must be accompanied by an adult to prevent accidents.
- When using, wear comfortable clothing and avoid wearing slippers or skirts.
- Start with the most appropriate amount of exercise, as excessive exercise can affect your health.
- The load weight of the product is 120kg. Overloading may cause failure or damage. Before using, make sure all parts are installed correctly and all screws and nuts are screwed into place.
- Consult your fitness instructor before use and use the equipment according to the instructions.

Note

- This product is a household machine. Avoid commercial use.
- Do not use in locations where fires may occur.
- When exercising, go to large areas where no one is around and keep away from
- Dangerous things.
- If this product is not used, the floor may be damaged. Be sure to lay a carpet.
- If you are not using the product, please do not put it in the following places:
 - A. place that is too hot or too cold.
 - B. The sun shines directly outside the house.
 - C. Place near the gas furnace or near the fire.
 - D. Cold and humid place.
 - E. Places where children can touch
 - F. Places where oil smoke and water vapor are generated.
- Do not use the product on a rough surface.

Installation diagram

Step 1: Open the box to check the product parts

<p>(A) Leg tube (2)</p>  A long, thin metal tube with a curved section at one end and a small protrusion.	<p>(B) Main frame (2)</p>  A metal frame consisting of two long horizontal bars connected by a vertical bar in the middle, with small protrusions at the ends.
<p>(C) Auxiliary pipe (2)</p>  A long, thin metal pipe with a slight curve at one end.	<p>(D) Foot connecting tube (1)</p>  A short metal tube with a small protrusion at one end.
<p>(E) Main pipe connection (1)</p>  A metal pipe with a central connector and two flanges at the ends.	<p>(F) Horizontal bar (1)</p>  A long metal bar with a curved section at one end and a small protrusion at the other.
<p>(G) Backrest tube (1)</p>  A long metal tube with a small rectangular plate attached to the center.	<p>(H) Elbow pad (1)</p>  A small, dark, rectangular pad with rounded corners.
<p>(I) Legrest adjustment tube(1)</p>  A short metal tube with a curved section.	<p>(J) Sit-up board support tube (1)</p>  A short metal tube with a small protrusion at one end.
<p>(K) Leg rest tube (1)</p>  A short metal tube with a small protrusion at one end.	<p>(L) Elbow pad (2)</p>  A small, dark, rectangular pad with rounded corners.
<p>(M) Sit-up board (1)</p>  A long, dark, rectangular board with a metal frame and a small protrusion at one end.	

Kit accessories

Step 1: Open the package to confirm the product components

<p>(1) Semi-circular square neck screw M8*40 (4 pieces)</p>	<p>(2) Hexagon socket head cap screws M8*70 (8 pcs)</p>	<p>(3) Hexagon socket head cap screws M8*80 (2 pcs)</p>
		
<p>(4) Hexagon socket head cap screws M8*40 (4 pcs)</p>	<p>(5) Hexagon socket head cap screws M8*15 (2 pcs)</p>	<p>(6) Hexagon socket head cap screws M8*50 (3 pcs)</p>
		
<p>(7) Plastic handle nut M8 (4 pieces)</p>	<p>(8) M8 nuts (21)</p>	<p>(9) Plastic handle screw M8*45 (4)</p>
		
<p>(10) Reinforced pad (2 pieces)</p>	<p>(11) Round gaskets (6)</p>	<p>(12) Curved gaskets (4)</p>
		
<p>(13) Curved pad (4 pieces)</p>	<p>(14) Plug (3 pieces)</p>	
		
<p>(15) External hexagon wrench (16) hex wrenches</p>		

Step 2: Take out the foot tube

1. Remove the left and right foot tube

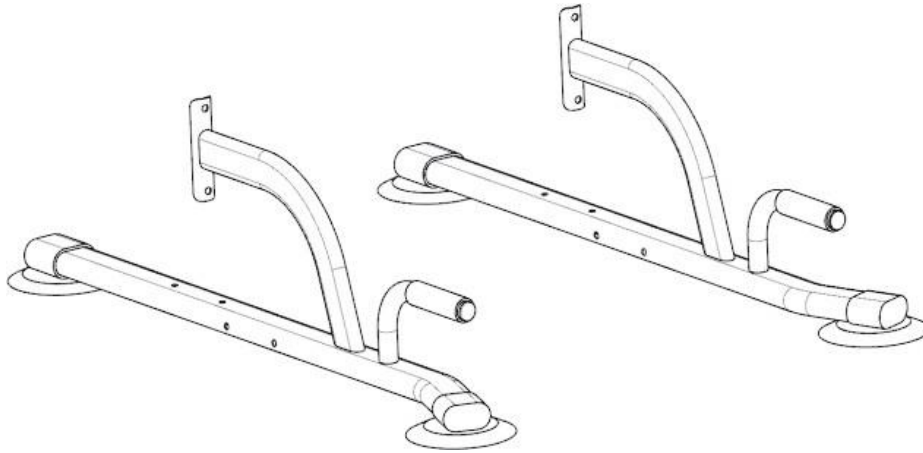

Step 3: Install the foot tube connecting tube

1. Use four M8*70 (2)hex screws to thread the foot tube from the inside, put the curved pad, and tighten the M8(8) nut.

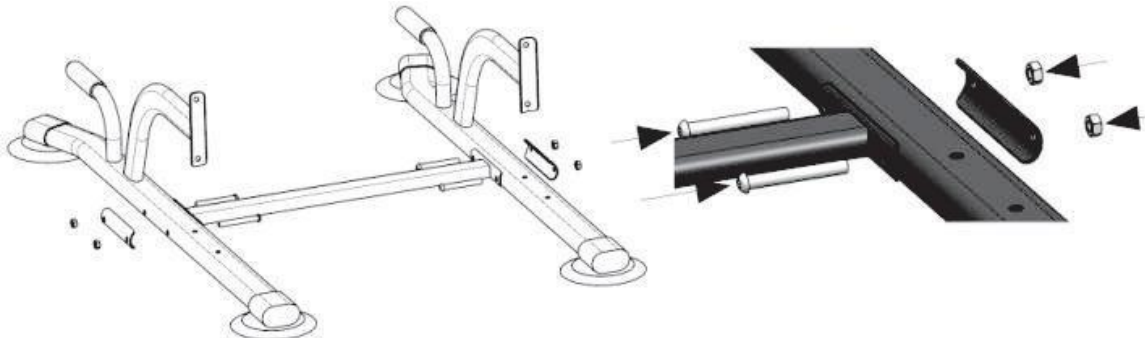

Step 4 ; install the main frame

1. Use 4 M8*40 round head square neck screws to pass through the foot tube from the bottom, put a circular gasket, and fasten with M8 nut.
2. Use four M8*70 hex socket screws to thread out from the inside, place the curved pad and fasten with the M8 nut.

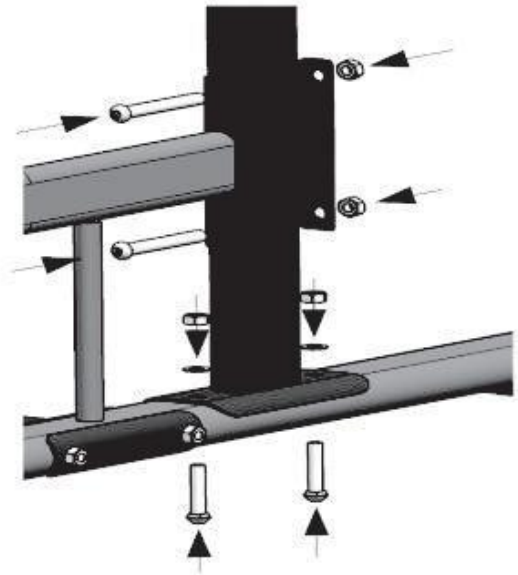
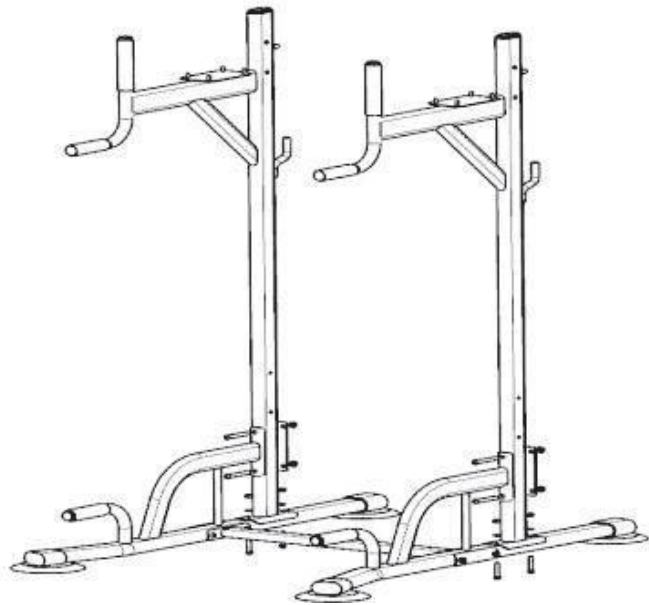

Step 5: Install the reinforcement tube

1. Use four M8*40 socket head cap screws, put on the reinforcing pad, penetrate from the outside, and fasten with the M8 nut.

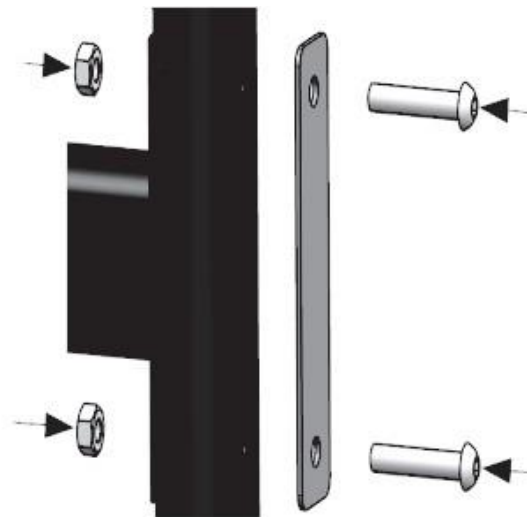
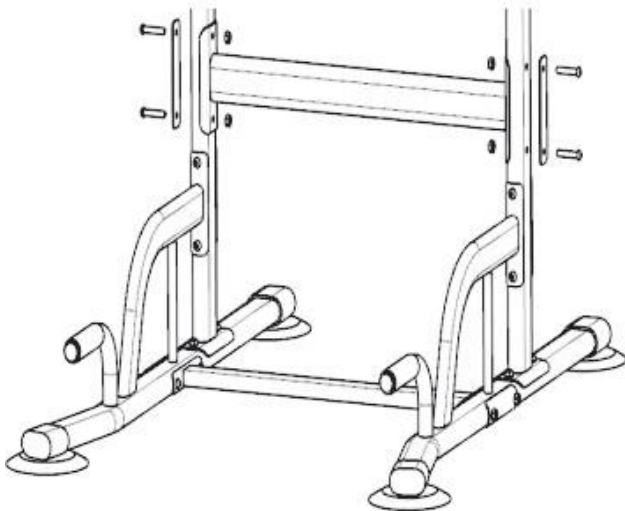

Step 6: Install the elbow pads

1. Use the self-contained screw on the elbow pad and tighten it through the iron plate.



Step 7: Installing the back cushion

1. Use the screws on the backrest tube to tighten through the sky and the back cushion.

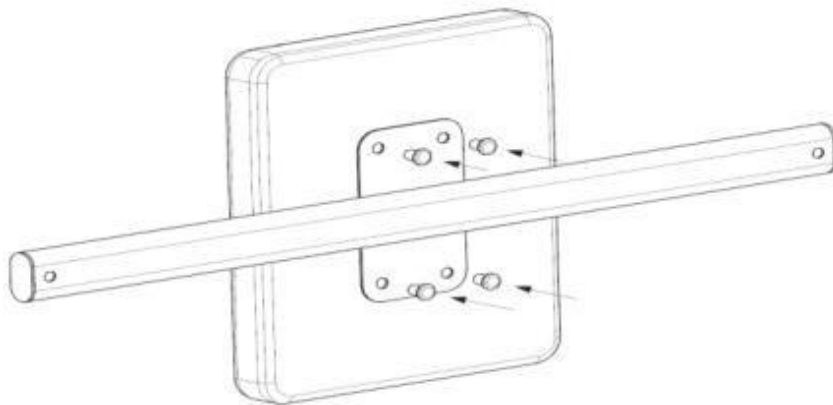

Step 8: Install the backrest lever

1. The inner and outer holes of the backrest tube (G) are inconsistent in diameter and the large holes are facing inward. Use the hexagonal screws of M8* 15(5), put the circular washer (11), and tighten the Allen key (16). .

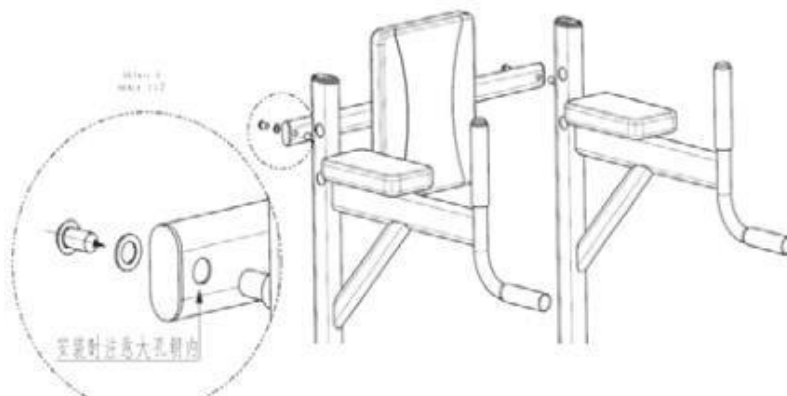

Step 9: Install the horizontal bar

1. Place the horizontal bar on the upper arm, align the hole with the M8*80 hex screw, place the curved washer, pass it through the bottom, add the curved washer, and tighten with the M8 nut.

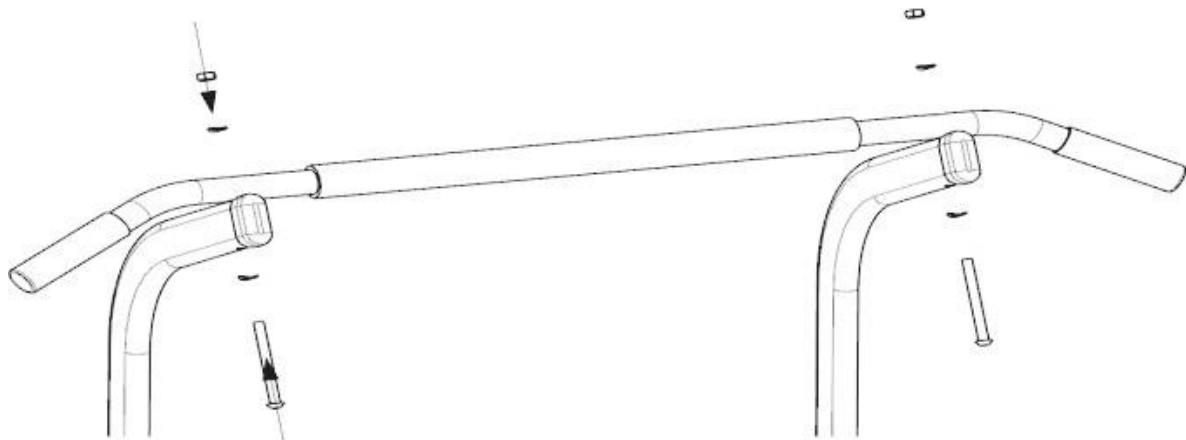

Step 10: Install the secondary pipe to adjust the height suitable for you

1. Put the sub-tube directly from the top of the main frame and adjust the hole position when adjusting to the appropriate height.
2. Fasten the M8 plastic nut with the M8*45 plastic handle screw through the main frame and the auxiliary pipe.

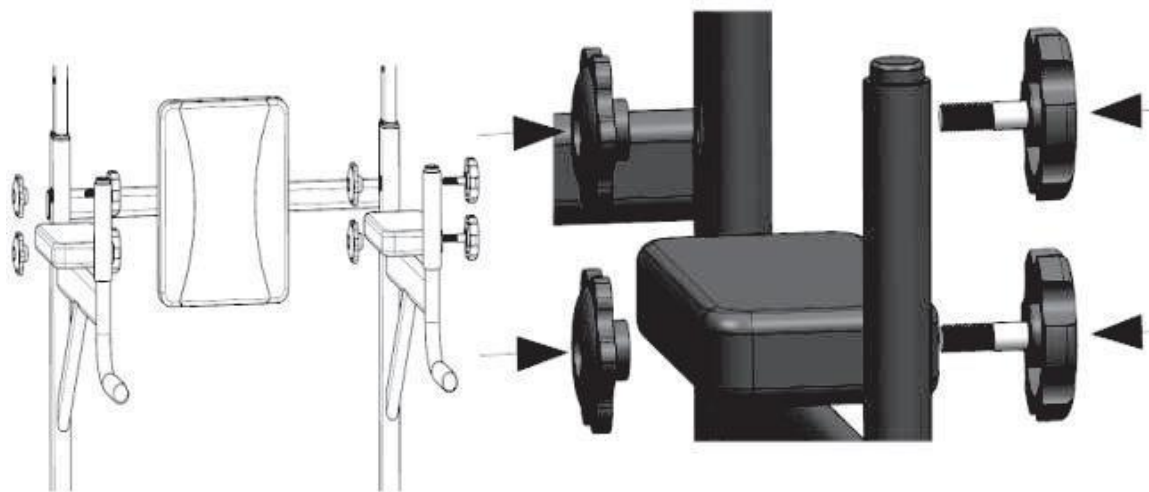

Step 11: Installing sit-up board

1. First attach the hole with the hole in the supine plate to the connecting plate, align the holes, and tighten with the M8 * 50 hex nut.

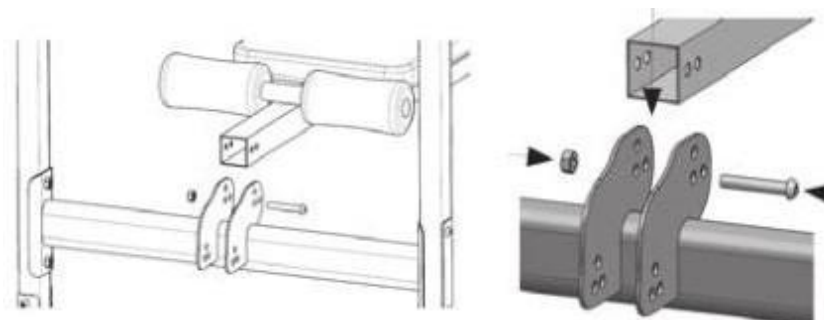

Step 12: Install the support plate of the supine plate

1. Align the support leg with the square tube hole of the supine plate, use the hexagonal screw of M8* 50 to pass through the square tube, and tighten the M8 nut with the hex wrench.



Step 13: Place the fixed pin

1. Insert the hole from the outside with the pin and fix the supine plate (Fig. 1 acts to prevent the supine plate from shaking. The figure acts as a fixed support leg.)

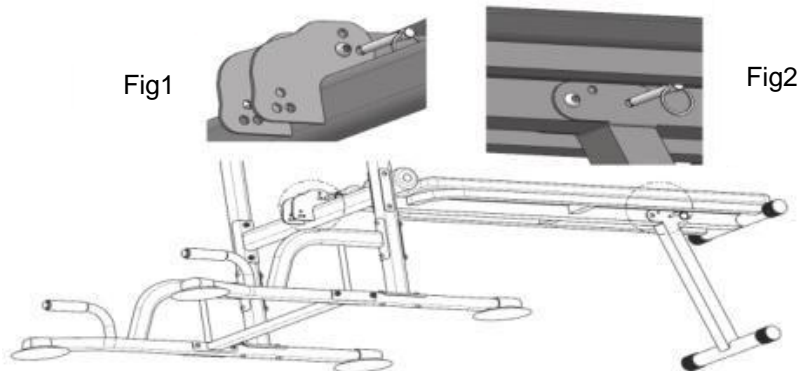

Step 14: Installing the footrest assembly

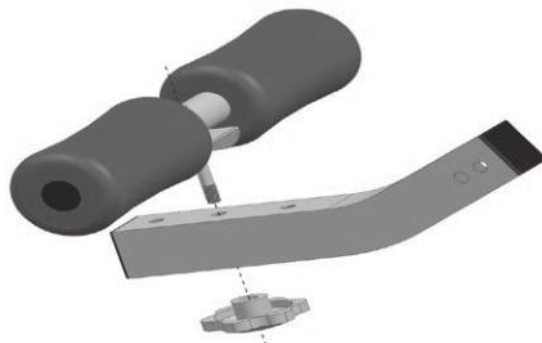

Step 15: Install the footrest

1. Align the footrest with the hole of the connecting piece. Insert it with an M8*50 hexagon socket screw from the outside and tighten the M8 nut.
2. Corresponding to 2 holes, it is inserted and fixed from the outside with a bolt (the tube angle can be adjusted)



Sit up folding:

1. The supine plate fixing pin in the flat state and the fixed supine plate tube pin are pulled out and folded upward (as shown in the figure).

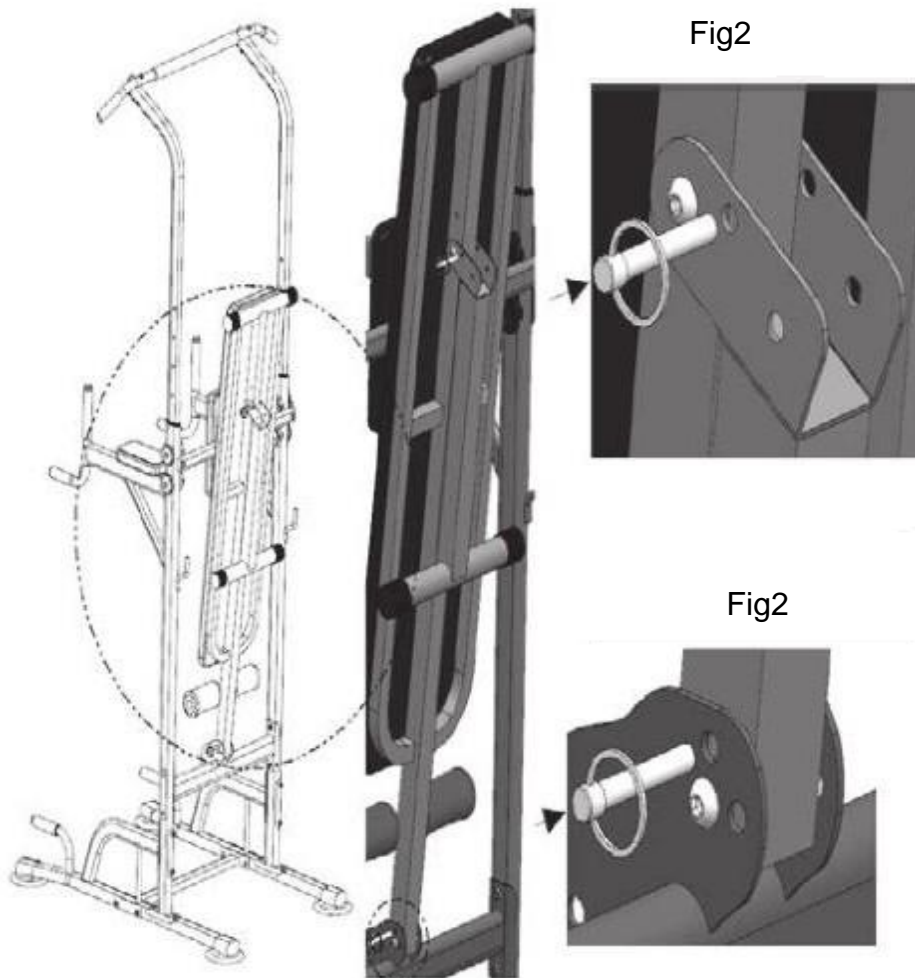

2. Pull out the supine plate fixing pin in the folded state. (Pay attention to holding the supine board.) Place the supine board down and level it to the ground.



US



001-877-644-9366
customerservice@aosom.com

CA



001-855-537-6088
customerservice@aosom.ca

UK



0044-800-240-4004
enquiries@mhstar.co.uk

DE



0049-(0)40-88307530
service@aosom.de

FR



0033-1-84166106
contact@aosom.fr

ES



0034-931294512
atencioncliente@aosom.es

IT



0039-0249471447
clienti@aosom.it