

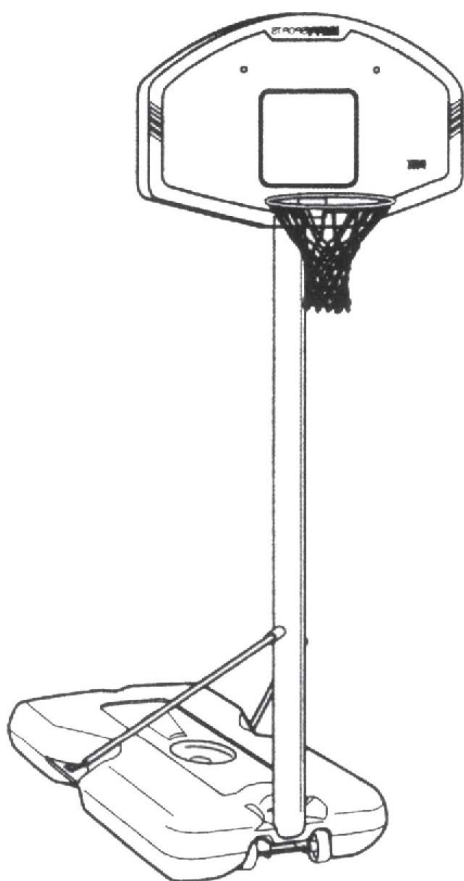

PORTABLE BASKETBALL SYSTEM-OWNERS MANUAL

INai011V03_UK_FR_ES_IT_A61-002



• Deluxe set Ø 66mm

• **Notice to assemblers:**

All the basketball systems, including those used for displays, must be assembled and ballasted according to instructions. Failure to follow instructions could result in serious injury.

Please read all warnings and cautions. It is recommended to supervise children as they play with this product. This product is to be assembled by adults only!

We appreciate your purchasing one of our many fine products. We are assure that you will be very satisfied with your selection.

IMPORTANT, RETAIN FOR FUTURE REFERENCE: READ CAREFULLY

▪ **!!WARNING!!**

FAILURE TO COMPLY WITH THESE WARNINGS COULD RESULT IN INJURY. FAILURE TO COMPLY COULD ALSO RESULT IN PROPERTY DAMAGE.

01. Never hang from the rim or climb on the pole as injury or property damage could occur. For these reasons do not perform dunking type activities on this system as it is not designed for such use. Do not allow children to climb on the basketball system.
02. Never leave the unit assembled without weight in the tank!
03. Check the tank frequently for leaks or a loose cap. Slow leakage could cause the system to tip over unexpectedly and damage the floor if used inside.
04. Climate, corrosion or misuse could result in system failure.
05. This system is not intended for children 3 and under.
06. To store the system: Drain the water from the tank and dismantle the system. Store in a dry ventilated place.
07. If technical assistance is required, contact our customer service department. Most injuries are caused by misuse and/or failure to follow instructions. Use caution when using the system.

▪ **POLE CARE AND SYSTEM MAINTENANCE:**

The life of your basketball system depends on many variables. The climate, exposure to corrosives such as salt, pesticides or herbicides and excessive use or misuse can all contribute to pole failure, which may cause property damage or personal injury.

Check your basketball system frequently for loose hardware, excessive wear and signs of corrosion. For safety reasons and to prolong the life of your basketball system, you must take the following preventive measures:

- a. Check all nuts and bolts. If any are loose, tighten them.
- b. Check all parts for excessive wear and tear. If necessary, replace any parts that have been worn or damaged through usage. Contact our customer service department for replacement parts.
- c. Inspect the warning sticker on the pole. If it is ripped, faded or illegible, call our customer service department to request a replacement sticker.
- d. Check all pole sections for visible rust, chipped or cracked paint. If either are present, do the following:
 1. Use an emery cloth to completely remove any rust or chipped paint.
 2. Clean the area with a damp cloth and allow it to dry.
 3. Apply two coats of a rust preventative, high gloss enamel to the area. Allow the paint to dry between two coats.

Important! It is not recommended to use the system outdoors in freezing / subzero conditions.

To drop the rim to 190cm you must remove a section of the pole.

1

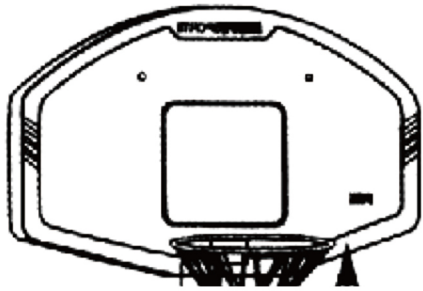

2

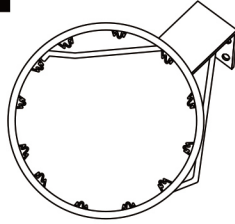

3

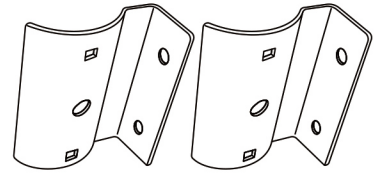

4

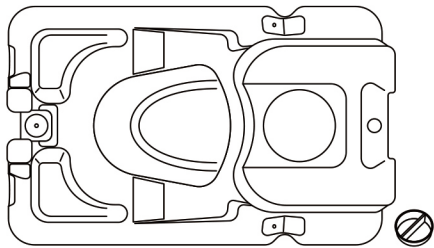

5



6



7



8



9



10

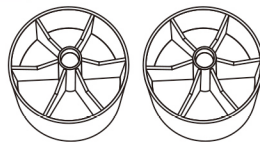

11



12

13

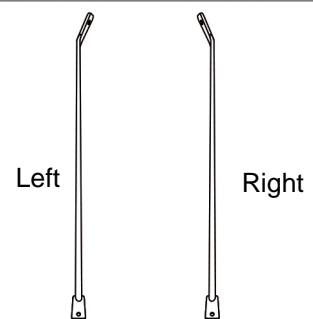

14

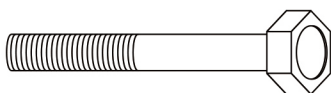

8X85mmX1pcs

15

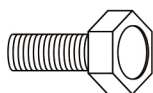

8X20mmX2pcs

16

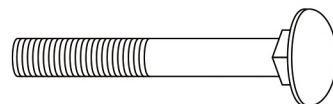

8X70mmX4pcs

17

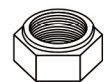

15 pcs

18

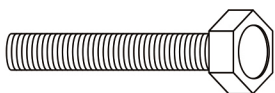

8X55mmX4pcs

19

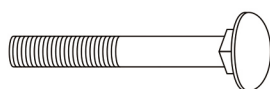

8X45mmX2pcs

20

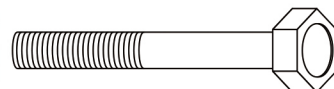

8X75mmX2pcs

21



18 pcs

22



14 pcs

01

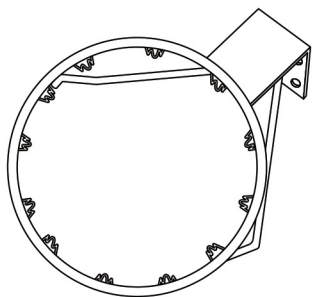

2

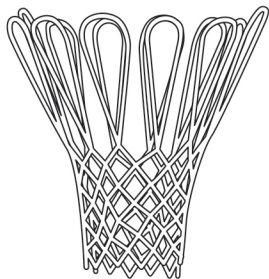

5

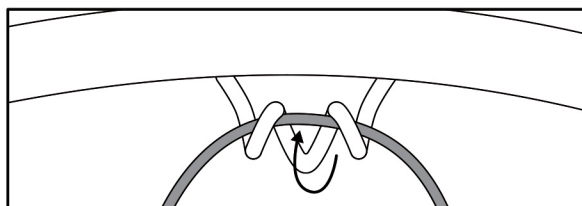
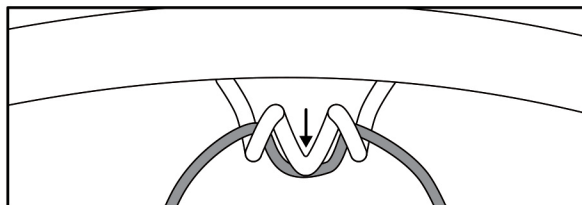
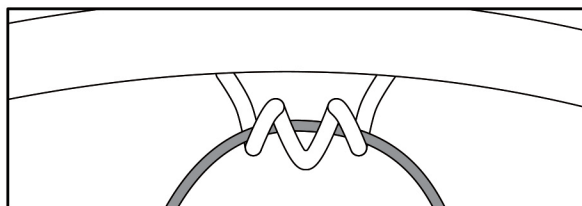

02

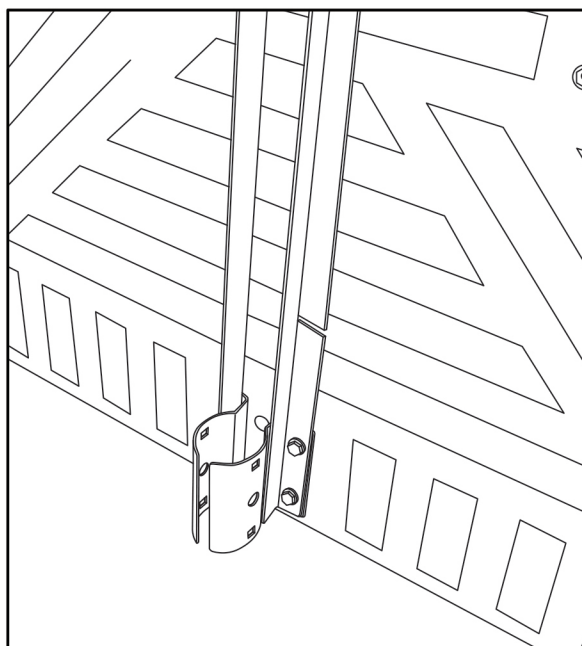
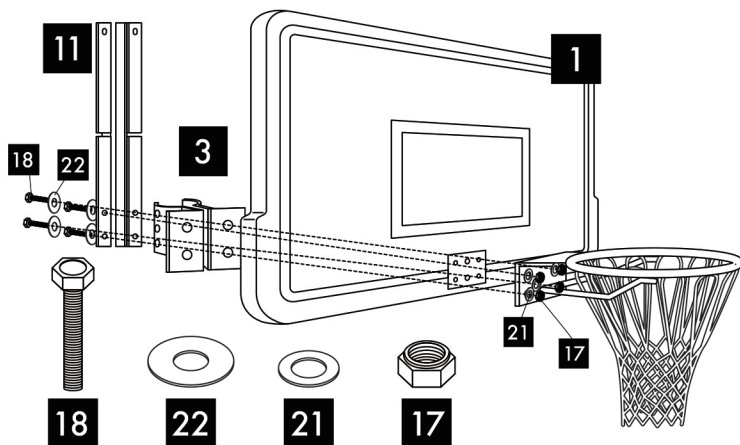

03



19



21

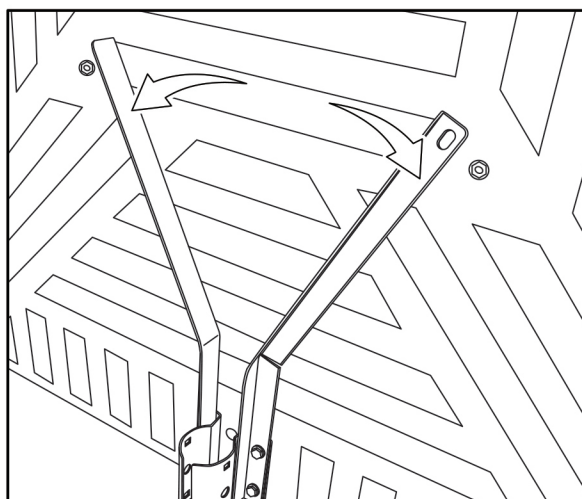
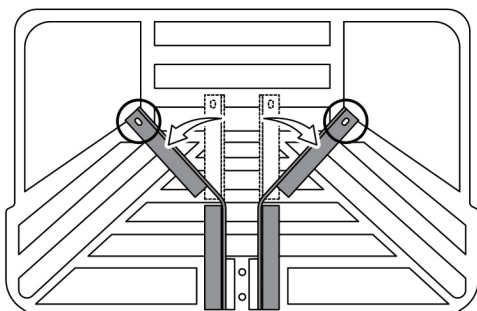

04

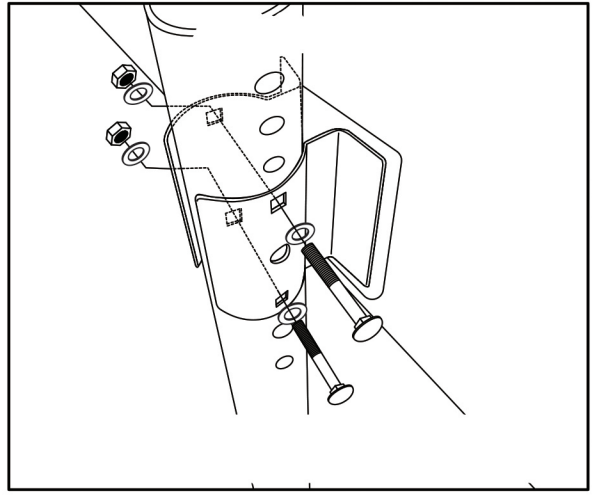
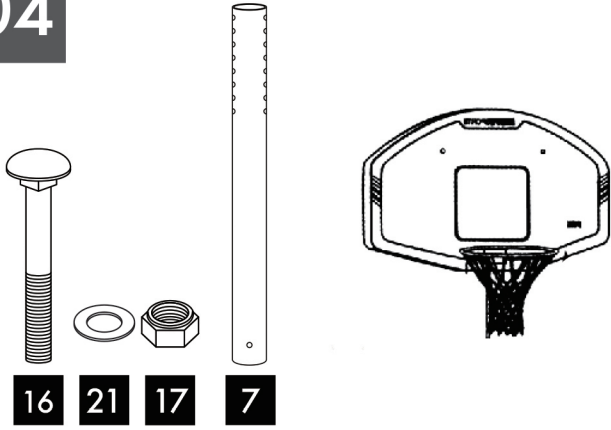

05

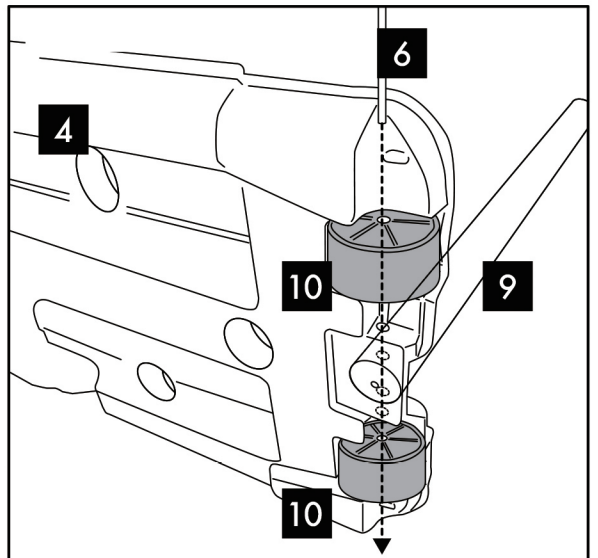
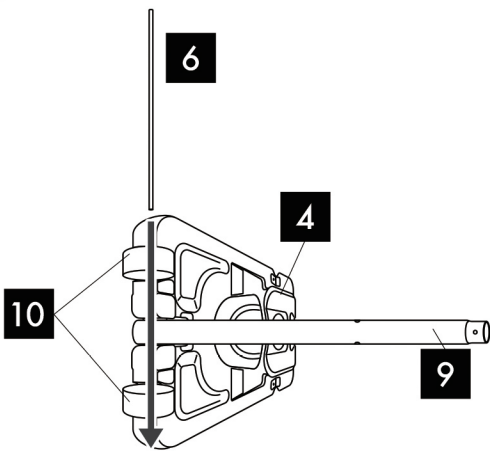

06

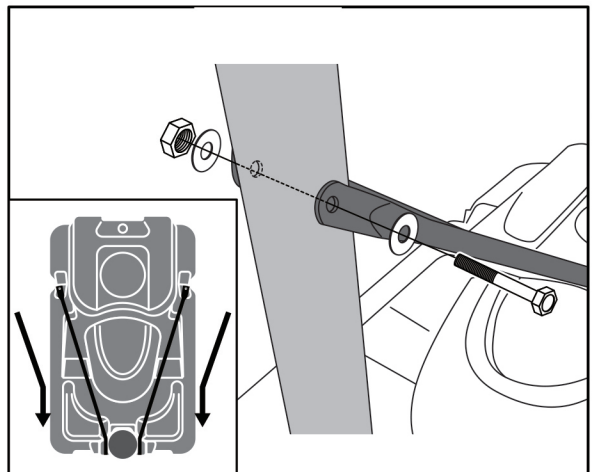
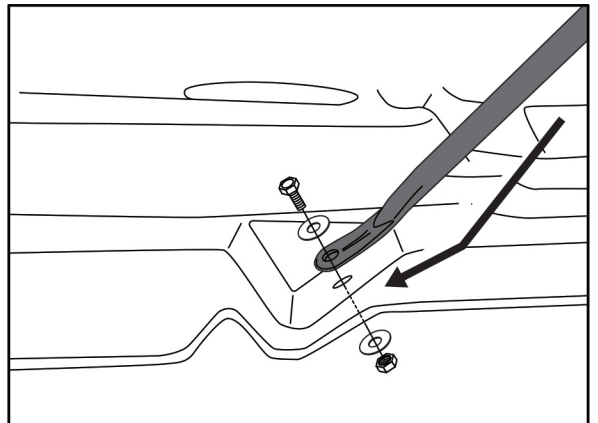
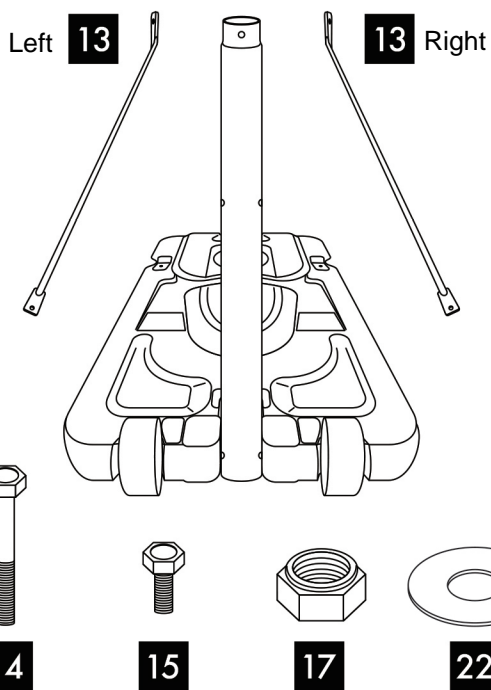

07

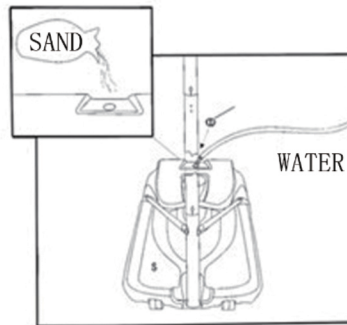
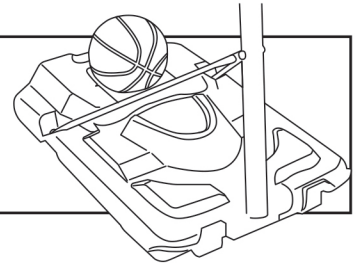
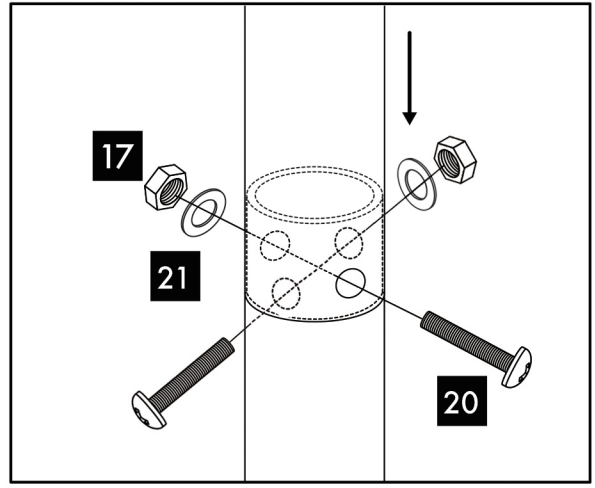
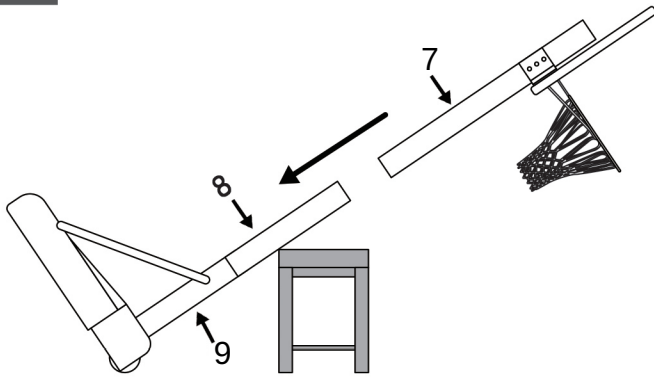

MANUEL D'INSTRUCTIONS POUR LE SYSTÈMES DE BASKET-BALL PORTABLE

FR

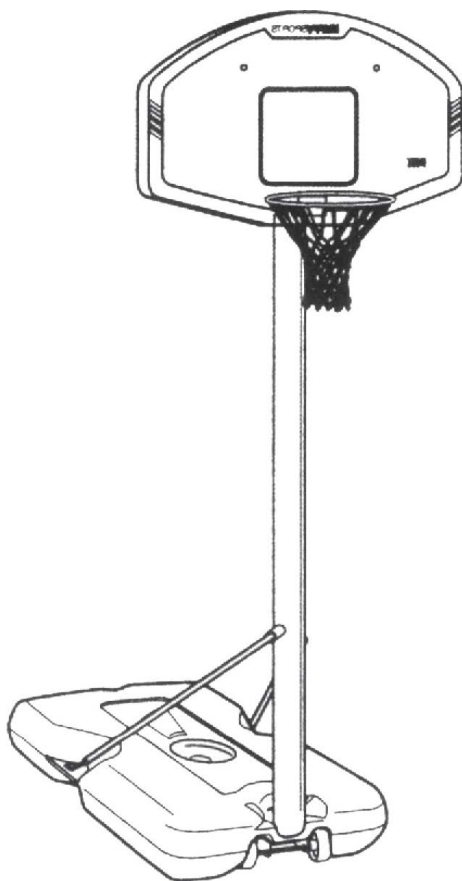

● Ensemble de luxe Ø 66mm

■ **Avis aux assembleurs :**

Tous les systèmes de basket-ball, y compris ceux utilisés pour les affichages, doivent être assemblés et ballastés selon les instructions. Le non-respect des instructions peut entraîner des blessures graves.

Veillez lire tous les avertissements et mises en garde. Il est recommandé de surveiller les enfants qui jouent avec ce produit. Ce produit doit être assemblé uniquement par des adultes !

Nous vous remercions d'avoir acheté l'un de nos nombreux produits de qualité. Nous sommes certains que vous serez très satisfaits de votre choix.

IMPORTANT - CONSERVEZ CES INFORMATIONS POUR VOTRE CONSULTATION ULTÉRIEURE: LISEZ ATTENTIVEMENT

■ **AVERTISSEMENT**

LE NON-RESPECT DE CES AVERTISSEMENTS POURRAIT ENTRAÎNER DES BLESSURES. LE NON-RESPECT DE CES AVERTISSEMENTS POURRAIT ÉGALEMENT ENTRAÎNER DES DOMMAGES MATÉRIELS.

1. Ne jamais s'accrocher au bord ou grimper sur le poteau, car cela pourrait entraîner des blessures ou des dommages matériels. Pour ces raisons, n'effectuez pas d'activités de type « dunking » sur ce système car il n'est pas conçu pour une telle utilisation. Ne permettez pas aux enfants de grimper sur le système de basket-ball.

2. Ne laissez jamais l'unité assemblée sans poids dans le réservoir !

3. Vérifiez fréquemment si le réservoir présente des fuites ou si le bouchon est desserré. Une fuite lente pourrait faire basculer le système de manière inattendue et endommager le sol s'il est utilisé à l'intérieur.

4. Le climat, la corrosion ou une mauvaise utilisation peuvent entraîner une défaillance du système.

5. Ce système n'est pas destiné aux enfants de 3 ans et moins.

6. Pour stocker le système : Vider l'eau du réservoir et démonter le système. Stocker dans un endroit sec et ventilé.

7. Si une assistance technique est nécessaire, contactez notre service clientèle. La plupart des blessures sont causées par une mauvaise utilisation et/ou le non-respect des instructions. Faites preuve de prudence lors de l'utilisation du système.

■ **ENTRETIEN DES POTEAUX ET MAINTENANCE DU SYSTÈME :**

La durée de vie de votre système de basket-ball dépend de nombreuses variables. Le climat, l'exposition à des produits corrosifs tels que le sel, les pesticides ou les herbicides et l'utilisation excessive ou abusive peuvent tous contribuer à la défaillance des poteaux, ce qui peut provoquer des dommages matériels ou des blessures.

Vérifiez fréquemment votre système de basket-ball afin de détecter tout matériel desserré, toute usure excessive et tout signe de corrosion. Pour des raisons de sécurité et pour prolonger la durée de vie de votre système de basket, vous devez prendre les mesures préventives suivantes :

a. Vérifiez tous les écrous et boulons. Si certains sont desserrés, serrez-les.

b. Vérifiez que toutes les pièces ne présentent pas d'usure excessive. Si nécessaire, remplacez toutes les pièces usées ou endommagées par l'utilisation. Contactez notre service clientèle pour obtenir des pièces de rechange.

c. Inspectez l'autocollant d'avertissement sur le poteau.1t s'il est déchiré, décoloré ou illisible, appelez notre service clientèle pour demander un autocollant de remplacement.

d. Vérifiez que toutes les sections du poteau ne présentent pas de rouille visible, d'écailles ou de fissures de peinture :

1. Utilisez une toile émeri pour enlever complètement la rouille ou la peinture écaillée.

2. Nettoyez la zone avec un chiffon humide et laissez-la sécher.

3. Appliquez deux couches d'un émail brillant antirouille sur la zone. Laissez la peinture sécher entre les deux couches.

1

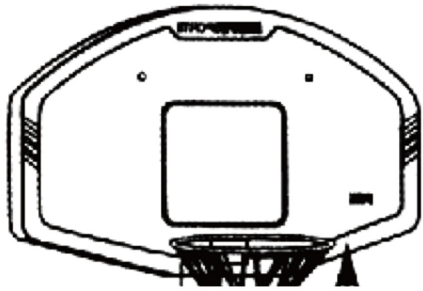

2

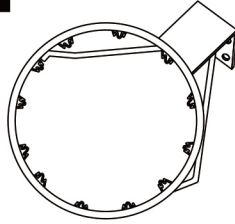

3

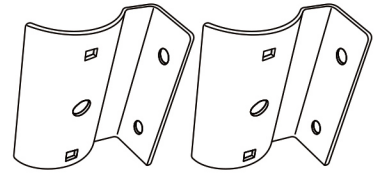

4

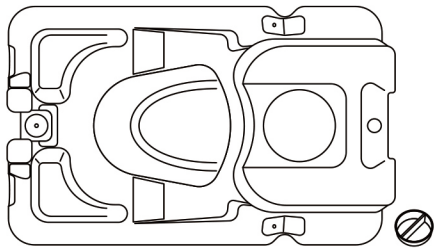

5



6



7



8



9



10

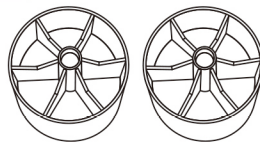

11



12

13

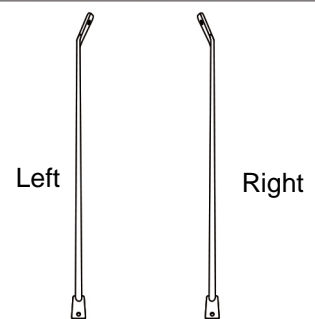

14

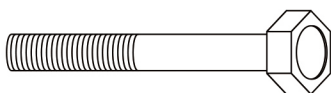

8X85mmX1pcs

15

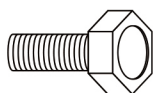

8X20mmX2pcs

16

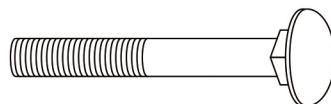

8X70mmX4pcs

17

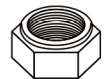

15 pcs

18

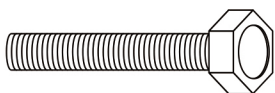

8X55mmX4pcs

19

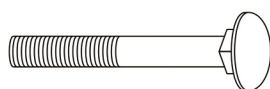

8X45mmX2pcs

20

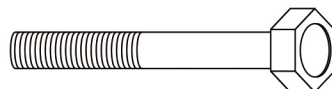

8X75mmX2pcs

21



18 pcs

22



14 pcs

01

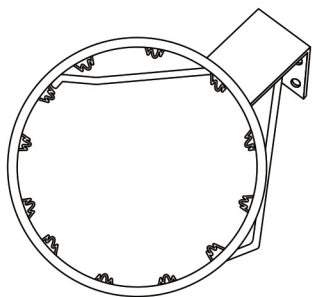

2

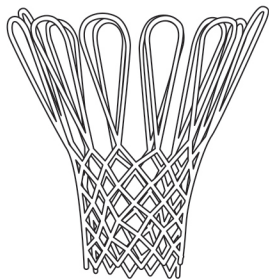

5

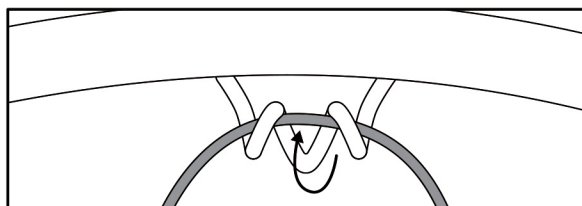
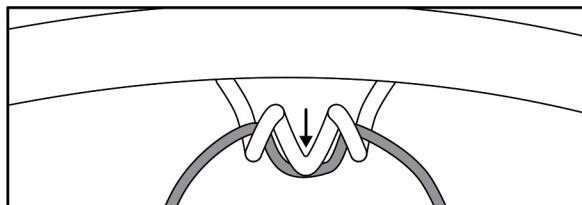
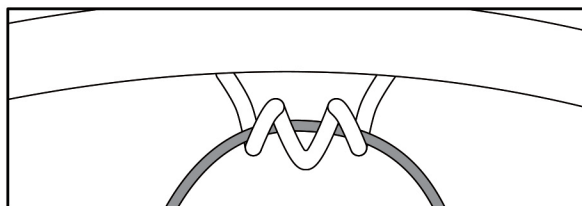

02

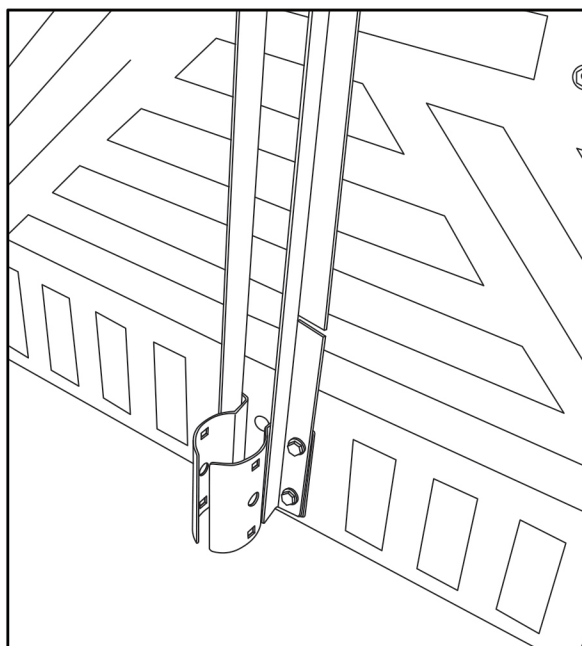
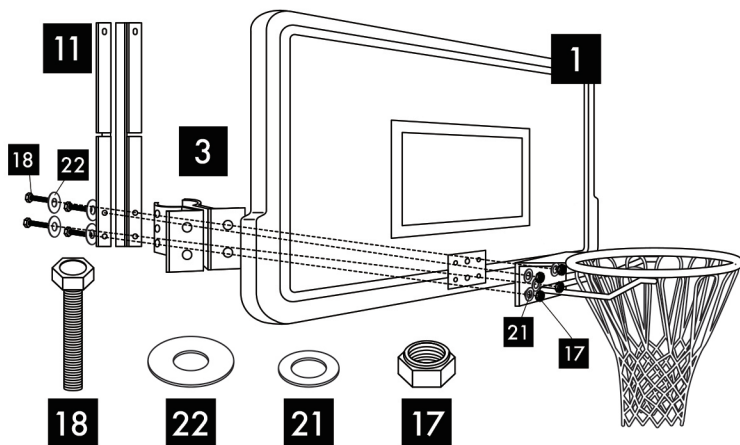

03



19



21

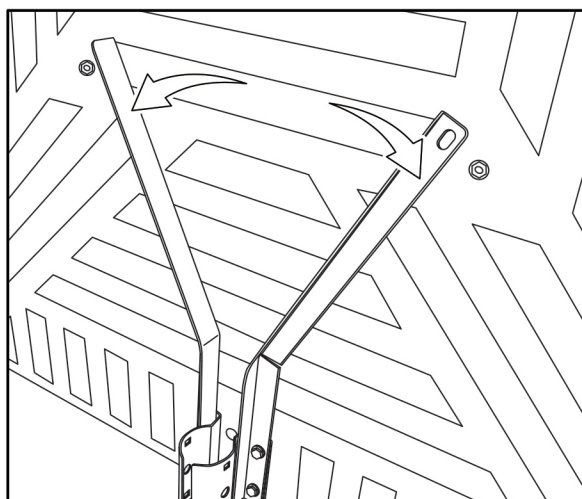
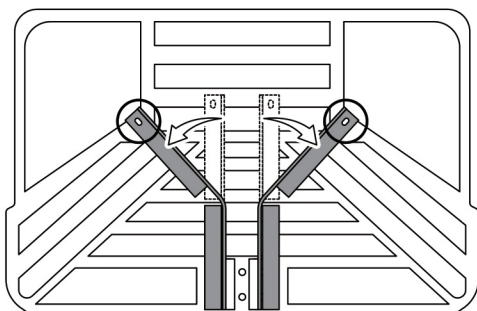

04

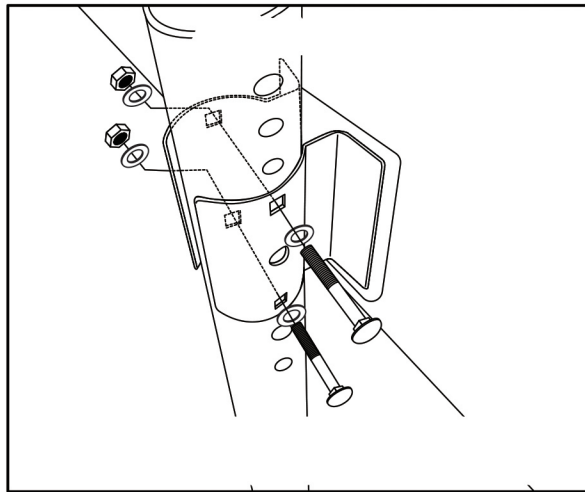
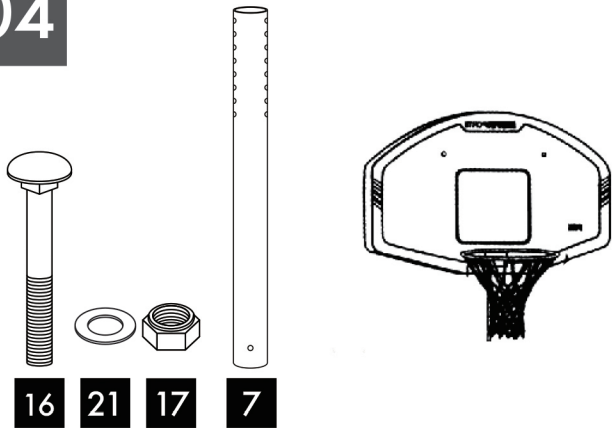

05

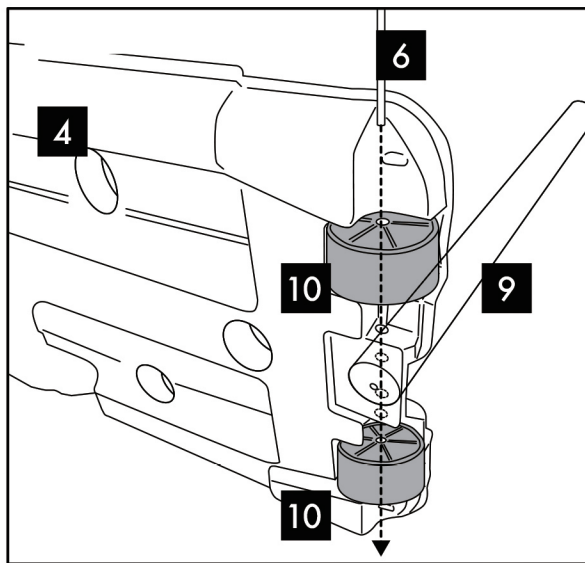
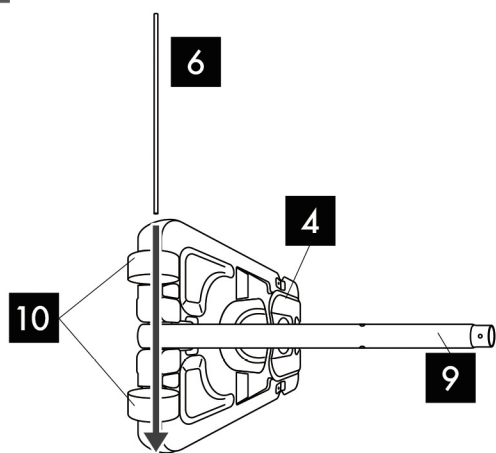

06

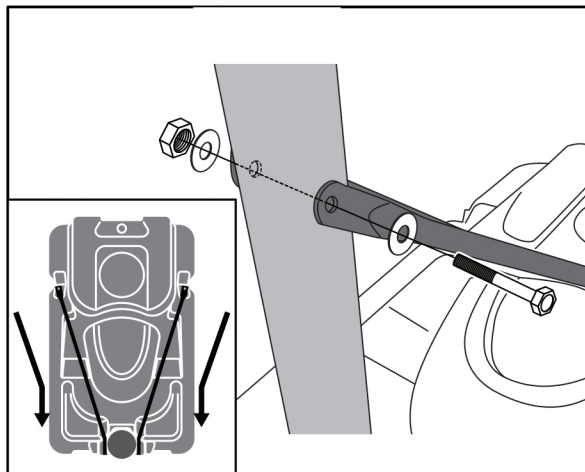
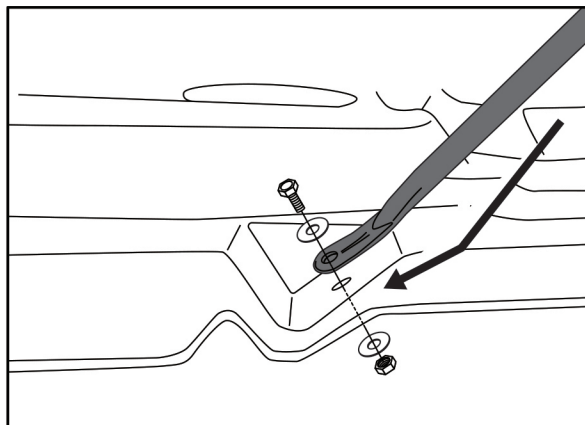
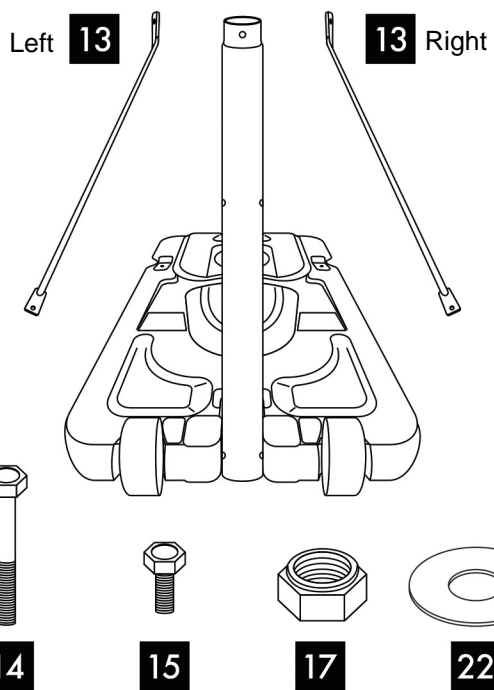

07

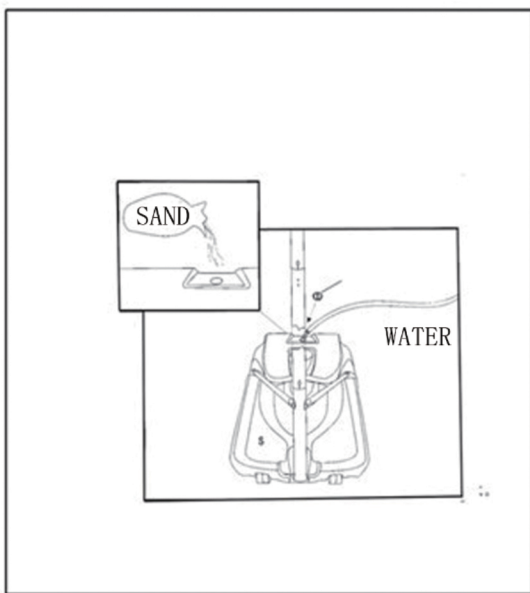
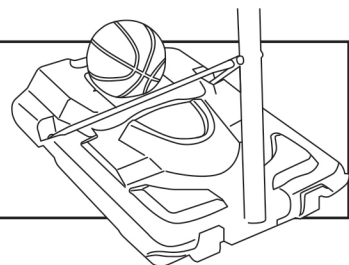
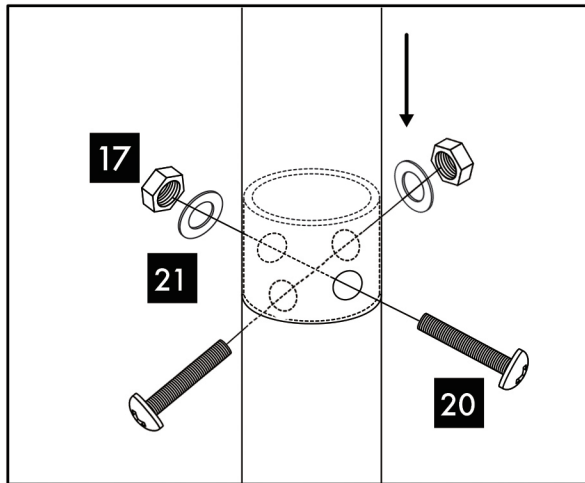
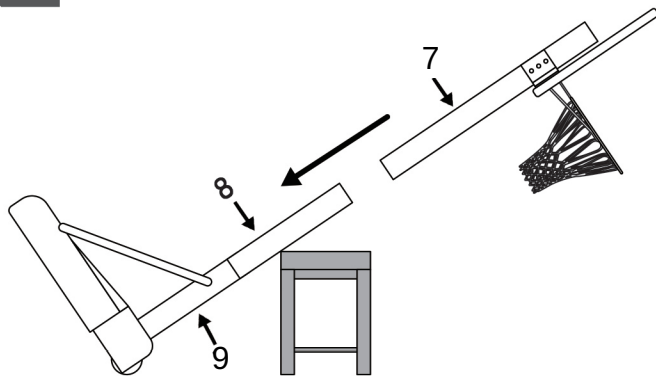

MANUAL DEL PROPIETARIO DEL SISTEMA DE BALONCESTO
PORTÁTIL
ES

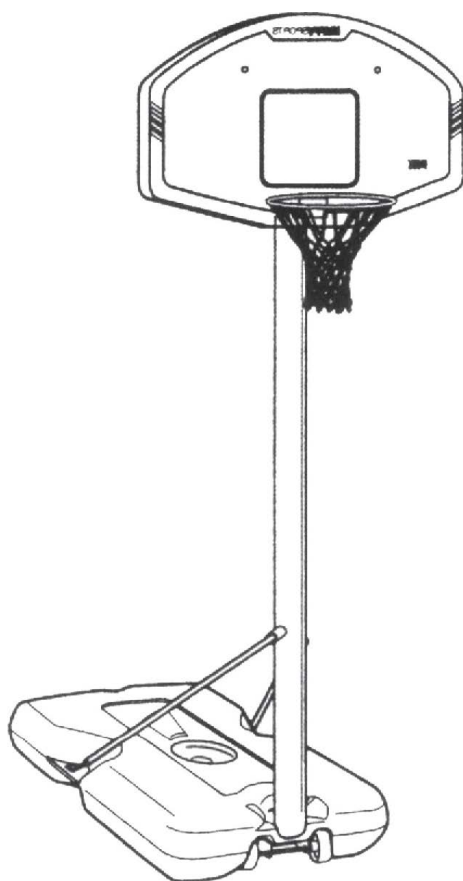

•Conjunto lujoso Ø 66mm

■ Aviso para los ensambladores:

Todos los sistemas de baloncesto, incluidos los utilizados para exhibiciones, deben ser montados y lastrados según las instrucciones. No seguir las instrucciones podría causar lesiones graves.

Lea todas las advertencias y precauciones cuidadosamente. Se recomienda supervisar a los niños cuando juegan con este sistema de baloncesto. ¡Este sistema de baloncesto solo debe ser montado por los adultos!

Agradecemos que usted haya comprado uno de nuestros muchos productos excelentes. Le aseguramos que quedará muy satisfecho con su compra.

**IMPORTANTE - CONSERVE ESTA INFORMACIÓN PARA SU
CONSULTA POSTERIOR: LEER DETALLADAMENTE**

■ADVERTENCIA

EL INCUMPLIMIENTO DE ESTAS ADVERTENCIAS PODRÍA CAUSAR LESIONES. EL INCUMPLIMIENTO TAMBIÉN PODRÍA CAUSAR DAÑOS A LA PROPIEDAD.

01. Nunca se cuelgue del borde ni se suba al poste, ya que podrían provocar lesiones o daños materiales. Por estas razones, no realice actividades de remojar en este sistema de baloncesto, ya que no está diseñado para tal uso. No permita que los niños se suban a este sistema de baloncesto.

02. ¡Nunca deje el sistema montado sin peso en el tanque!

3. Revise el tanque frecuentemente para detectar si hay fugas o si la tapa está suelta. Las fugas lentas pueden hacer que el sistema de baloncesto vuelque de manera inesperada y dañe el piso si se utiliza en interiores.

4. El clima, la corrosión o el mal uso pueden causar fallas del sistema.

5. Este sistema no está diseñado para el uso de los niños menores de 3 años.

6. Para almacenar el sistema: Drene el agua o arena del tanque y desarme el sistema de baloncesto. Almacénelo en un lugar seco y ventilado.

07. Si necesita asistencia técnica, comuníquese con nuestro departamento de atención al cliente. La mayoría de las lesiones son provocadas por mal uso y / o no seguir las instrucciones. Tenga cuidado al utilizar el sistema de baloncesto.

■CUIDADO DEL POSTE Y MANTENIMIENTO DEL SISTEMA DE BALONCESTO:

La vida útil de su sistema de baloncesto depende de muchos factores variables. El clima, la exposición a corrosivos como la sal, pesticidas o herbicidas y el uso excesivo o mal uso pueden causar la falla del poste y provocar daños a la propiedad o lesiones personales.

Inspeccione su sistema de baloncesto frecuentemente para ver si hay hardware suelto, desgaste excesivo y signos de corrosión. Para proteger la seguridad y para prolongar la vida útil de su sistema de baloncesto, debe tomar las siguientes medidas preventivas:

a. Inspeccione todas las tuercas y tornillos. Si están flojos, apriételes.

b. Inspeccione todas las piezas para ver si hay desgaste excesivo. Si es necesario, reemplace las piezas que se hayan desgastado o dañado durante el uso. Comuníquese con nuestro departamento de servicio al cliente para obtener las piezas de repuesto.

c. Lea la etiqueta de advertencia en el poste. Si está rasgada, descolorida o ilegible, comuníquese con nuestro departamento de servicio al cliente para obtener una etiqueta de reemplazo.

d. Inspeccione todas las secciones del poste para ver si hay óxido visible, pintura astillada o agrietada:

1. Utilice un paño de esmeril para quitar cualquier óxido o pintura descascarada completamente.

2. Limpie el área con un paño húmedo y déjelo secarse.

3. Aplique dos capas de esmalte de alto brillo en el área para prevenir la oxidación. Deje que la pintura entre dos capas se seque.

1

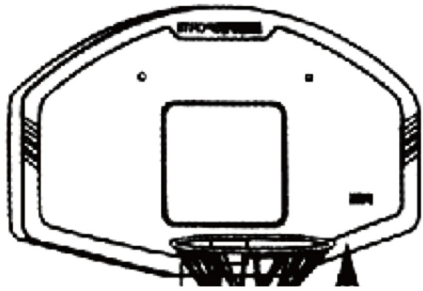

2

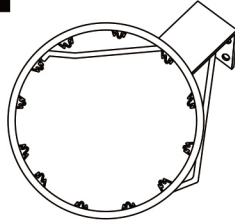

3

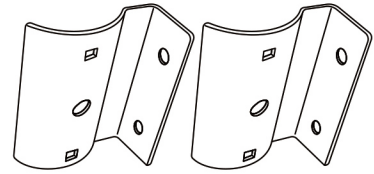

4

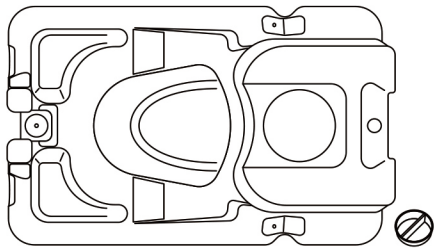

5



6



7



8



9



10

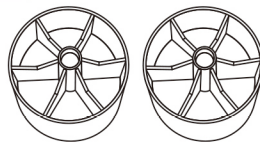

11



12

13

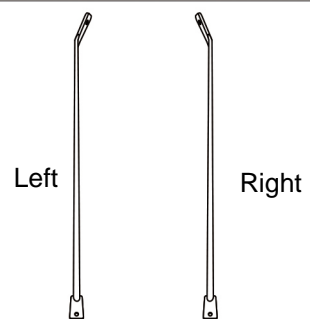

14

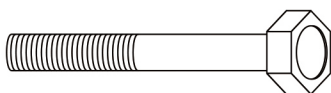

8X85mmX1pcs

15

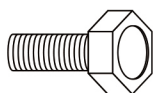

8X20mmX2pcs

16

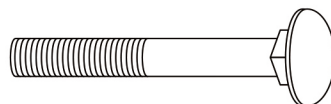

8X70mmX4pcs

17

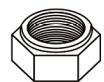

15 pcs

18

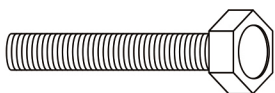

8X55mmX4pcs

19

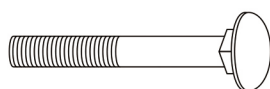

8X45mmX2pcs

20

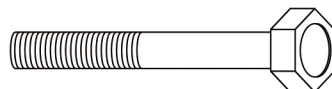

8X75mmX2pcs

21



18 pcs

22



14 pcs

01

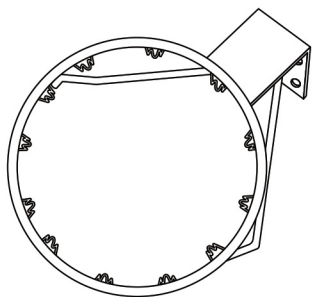

2

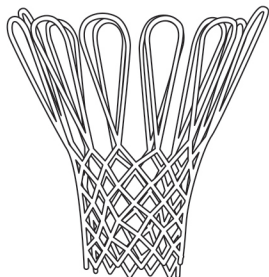

5

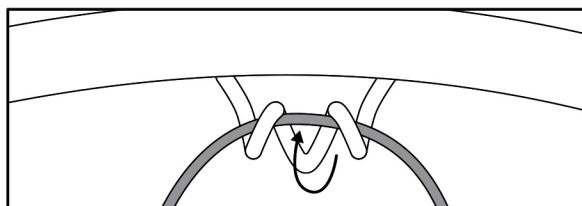
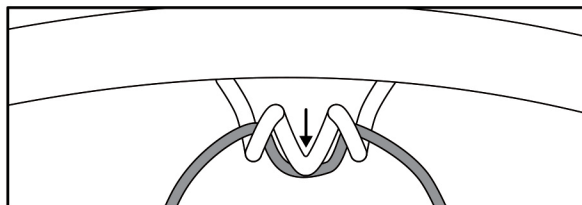
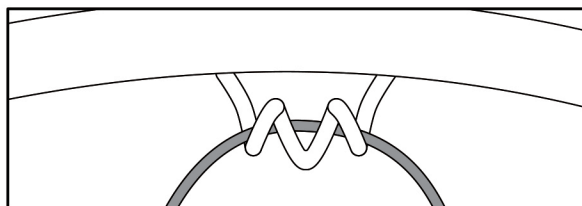

02

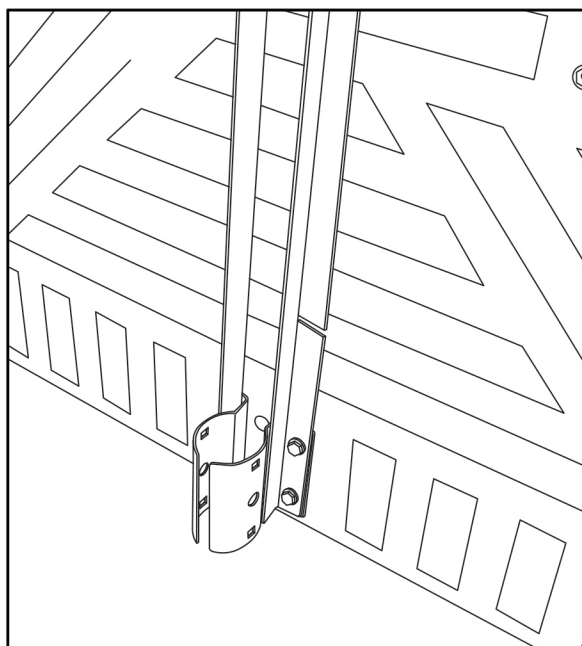
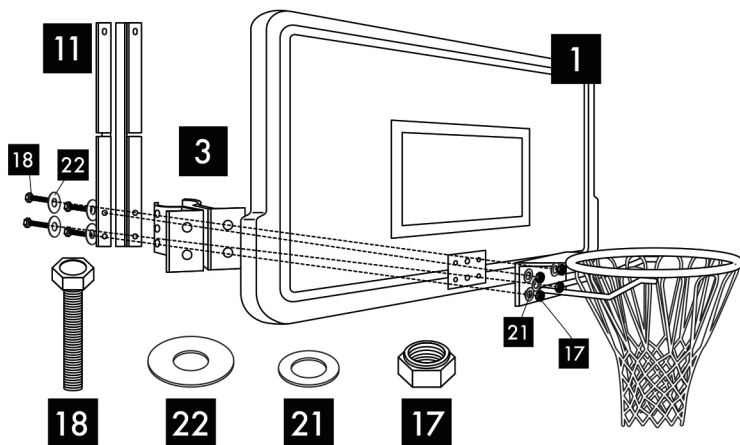

03



19



21

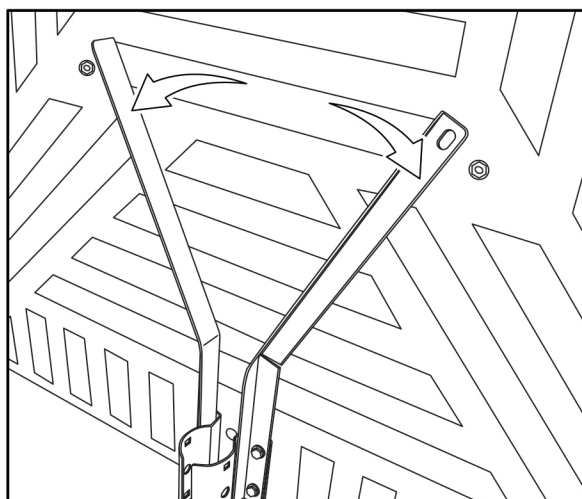
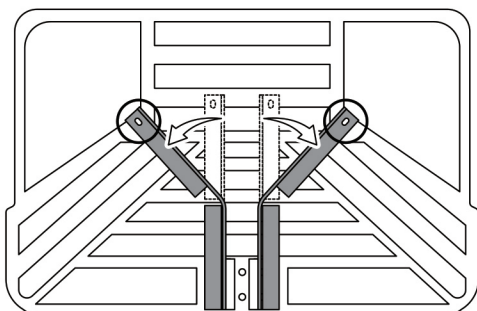

04

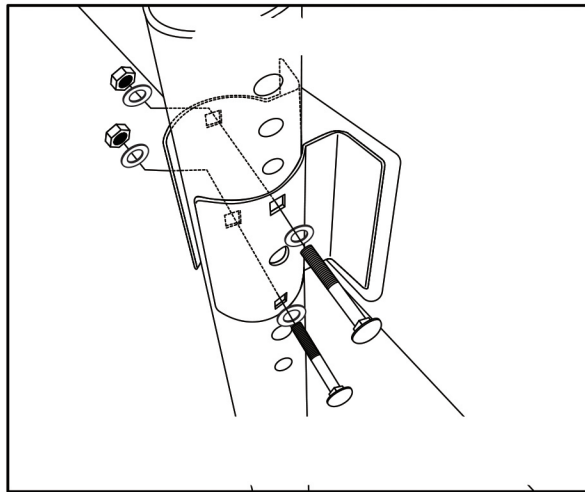
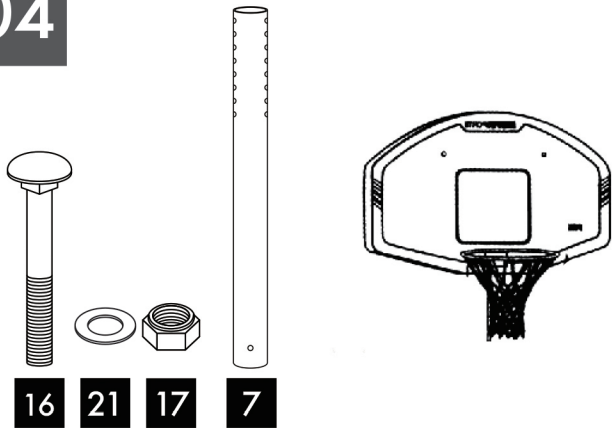

05

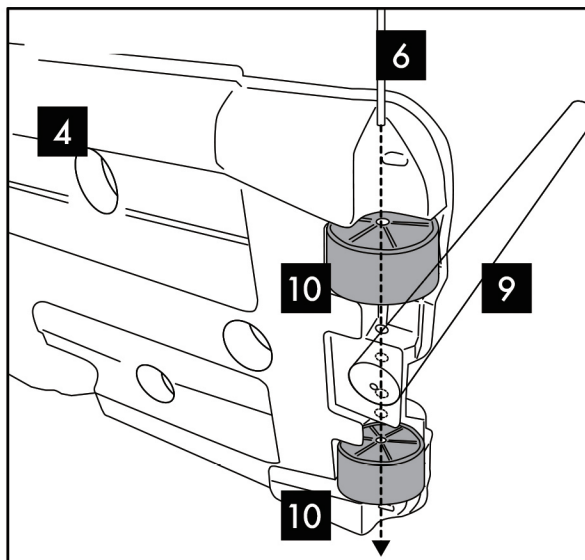
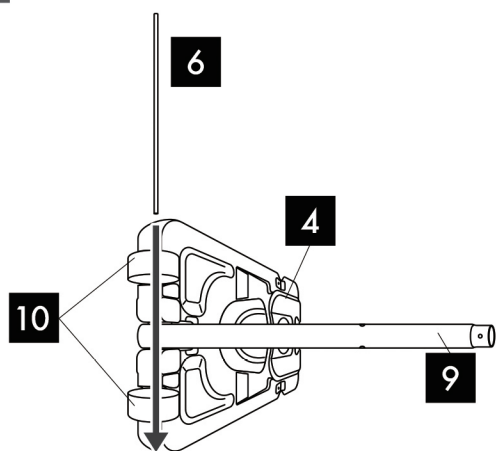

06

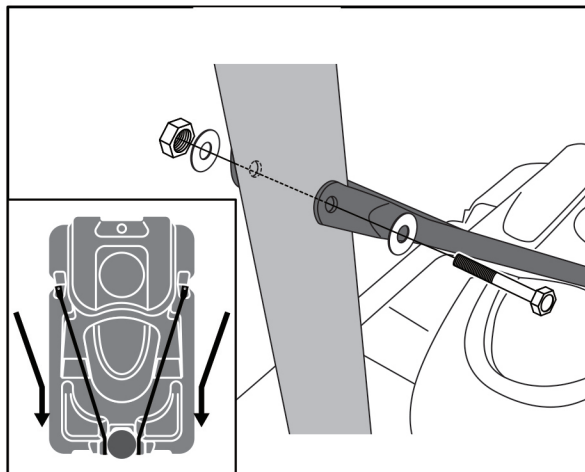
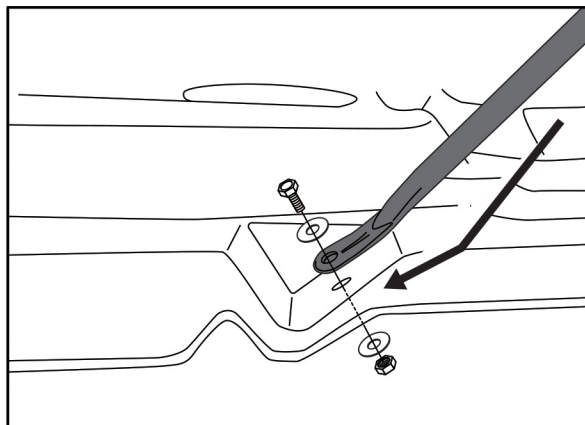
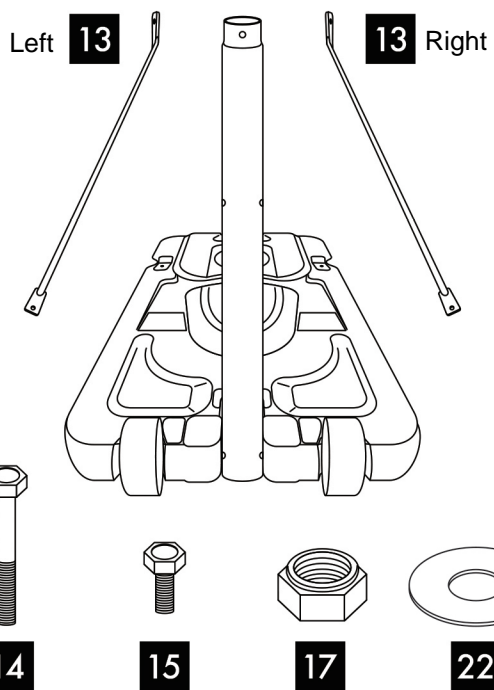

07

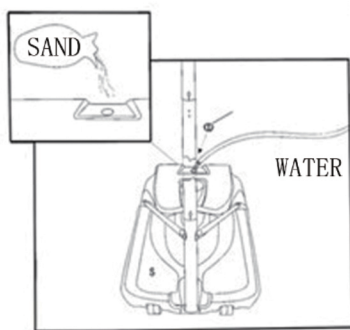
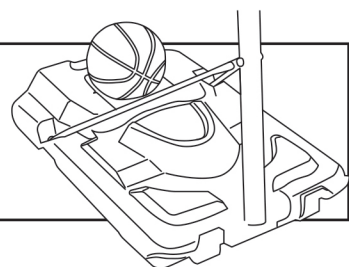
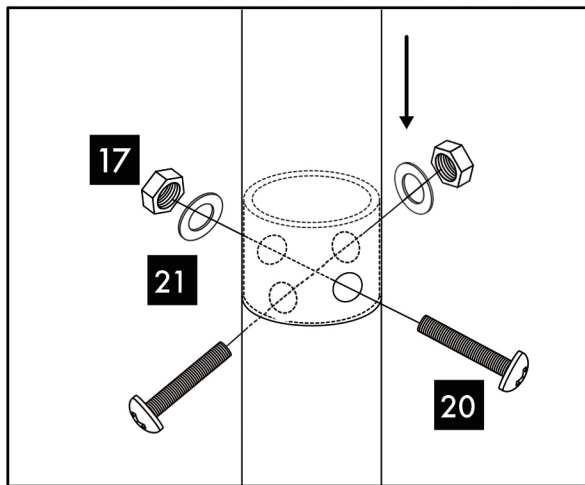
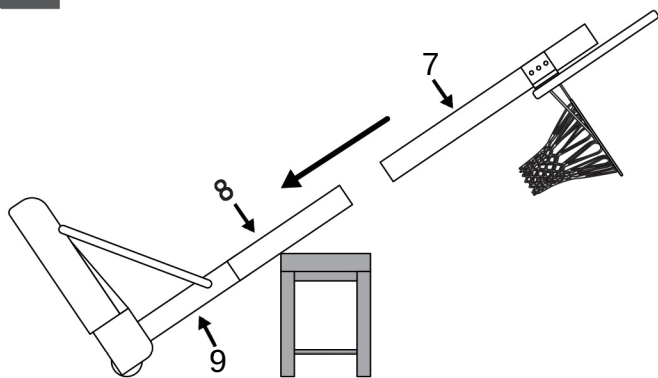

IMPIANTO BASKET PORTATILE-MANUALE DELL'UTENTE

IT

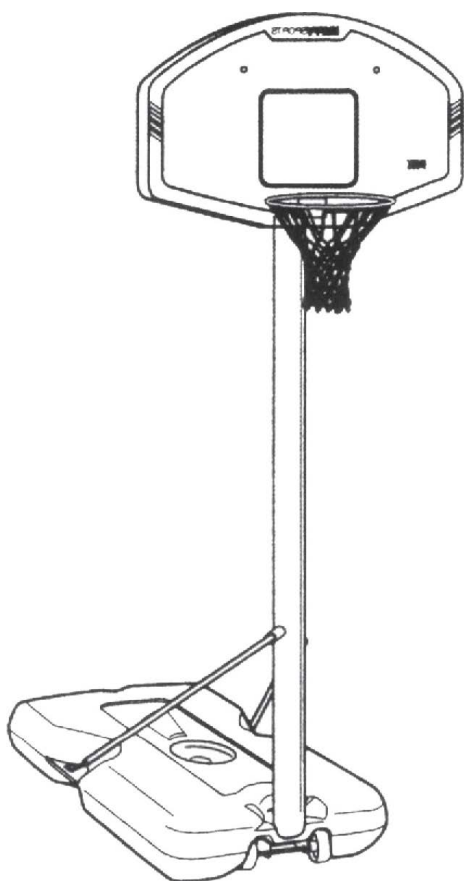

● Set Deluxe Ø 66mm

●Avviso al montatore:

Tutti gli impianti basket, compresi quelli utilizzati per le esposizioni, devono essere montati e zavorrati secondo le istruzioni. La mancata osservanza delle istruzioni potrebbe comportare lesioni gravi.

Si prega di leggere tutte le avvertenze e le precauzioni. Consigliamo di sorvegliare i bambini durante il gioco con questo prodotto. Questo prodotto va assemblato solo da adulti!

Apprezziamo il vostro acquisto di uno tra i tanti dei nostri ottimi prodotti. Siamo certi che sarete molto soddisfatti della vostra scelta.

**IMPORTANTE - CONSERVARE QUESTE INFORMAZIONI PER
CONSULTARLE IN SEGUITO: LEGGERE ATTENTAMENTE**

■ **AVVERTENZE**

IL MANCATO RISPETTO DI QUESTE AVVERTENZE POTREBBE COMPORTARE LESIONI. LA LORO MANCATA OSSERVANZA POTREBBE PROVOCARE ANCHE DANNI MATERIALI.

1. Non appendersi mai al canestro o salire sul palo poiché ciò potrebbe comportare lesioni o danni alla proprietà. Per questi motivi, non eseguire schiacciate su questo impianto in quanto non è progettato per tale scopo. Non permettere ai bambini di salire sull'impianto da basket.

2. Non lasciare mai l'unità montata senza zavorra nel serbatoio!

3. Controllare spesso il serbatoio per rilevare eventuali perdite o se il tappo è allentato. Una perdita lenta potrebbe causare il ribaltamento imprevisto del sistema e danneggiare il pavimento se utilizzato all'interno.

4. Il clima, la corrosione o l'uso improprio potrebbero portare a guasti dell'impianto.

5. Questo impianto non è destinato all'uso da parte di bambini di età inferiore a 3 anni

6. Per riporre l'impianto: scaricare l'acqua dal serbatoio e smontarlo. Conservarlo in un luogo asciutto e ventilato.

7. Se è necessaria assistenza tecnica, contattare il nostro servizio clienti. La maggior parte delle lesioni personali è causata da un uso improprio e / o dalla mancata osservanza delle istruzioni. Prestare attenzione durante l'utilizzo dell'impianto.

■ **CURA DEL PALO E MANUTENZIONE DELL'IMPIANTO:**

La vita del vostro impianto da basket dipende da molte variabili. Il clima, l'esposizione a sostanze corrosive come sale, pesticidi o diserbanti e l'uso eccessivo o improprio sono tutti elementi che possono contribuire al guasto del palo, il quale può causare danni alla proprietà o lesioni personali.

Controllare frequentemente il vostro impianto da basket per rilevare eventuali parti allentate, usura eccessiva o segni di corrosione. Per motivi di sicurezza e per prolungare la vita del vostro impianto da basket, adottare le seguenti misure preventive:

a. Controllare tutti i dadi e i bulloni. Se sono allentati, stringerli.

b. Controllare tutte le parti per verificare lo stato di usura. Se necessario, sostituire le parti usurate o danneggiate durante l'uso. Contattare il nostro servizio clienti per richiedere le parti di ricambio.

c. Ispezionare le etichette di avvertenza sul palo. Se sono strappate, sbiadite o illeggibili, contattare il nostro servizio clienti per richiedere un'etichetta sostitutiva.

d. Controllare tutte le sezioni dei pali per verificare se vi è ruggine, vernice scheggiata o incrinata. Se queste sono presenti, procedere come segue:

1. Utilizzare uno smerigliatore per rimuovere completamente la ruggine o la vernice scheggiata.

2. Pulire l'area con un panno umido e lasciarla asciugare.

3. Applicare due mani di uno smalto lucido antiruggine sull'area. Lascia asciugare la vernice tra le due mani.

1

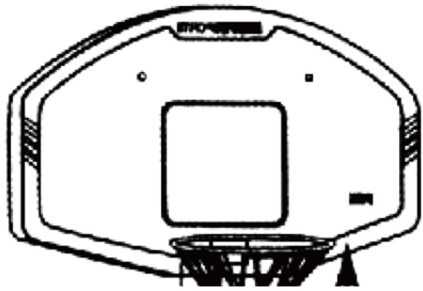

2

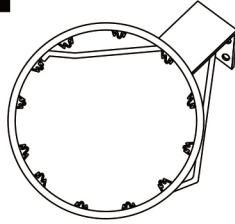

3

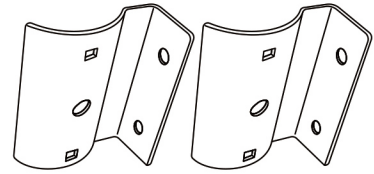

4

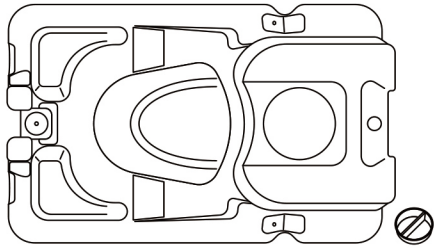

5



6



7



8



9



10

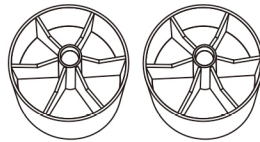

11

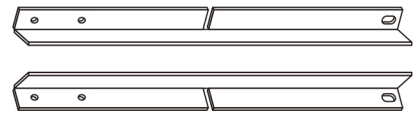

12

13

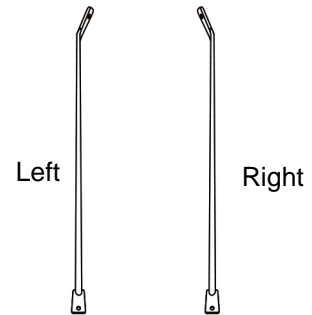

14

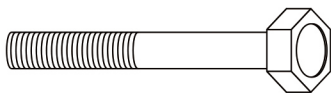

8X85mmX1pcs

15

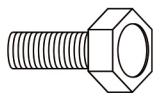

8X20mmX2pcs

16

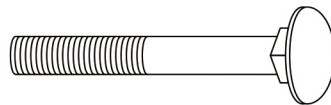

8X70mmX4pcs

17

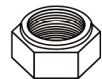

15 pcs

18

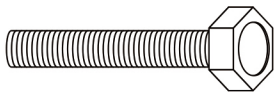

8X55mmX4pcs

19

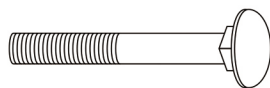

8X45mmX2pcs

20

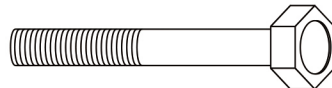

8X75mmX2pcs

21



18 pcs

22



14 pcs

01

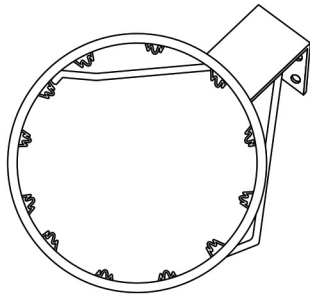

2



5

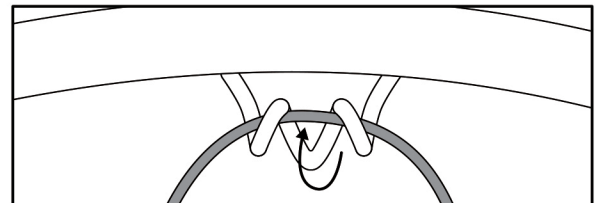
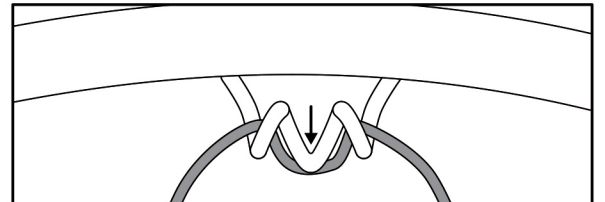
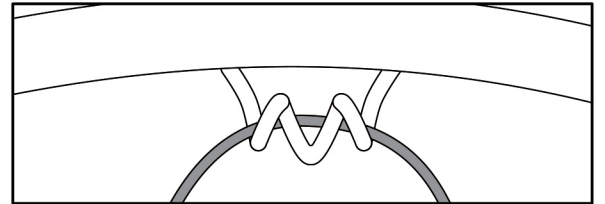

02

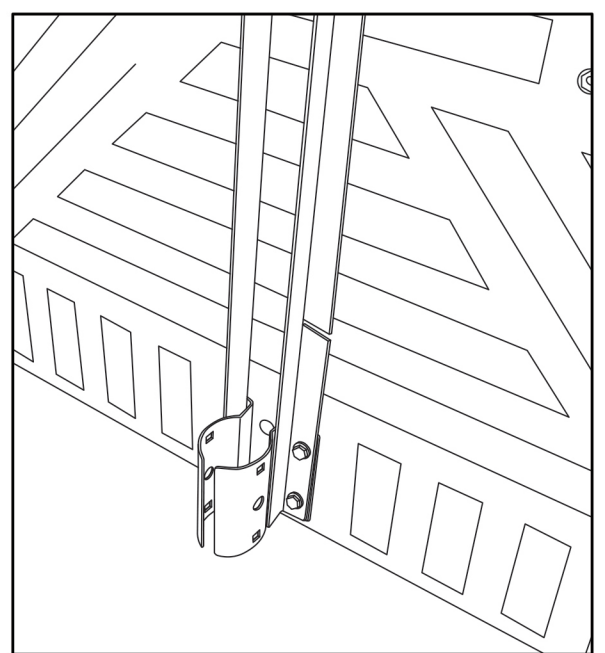
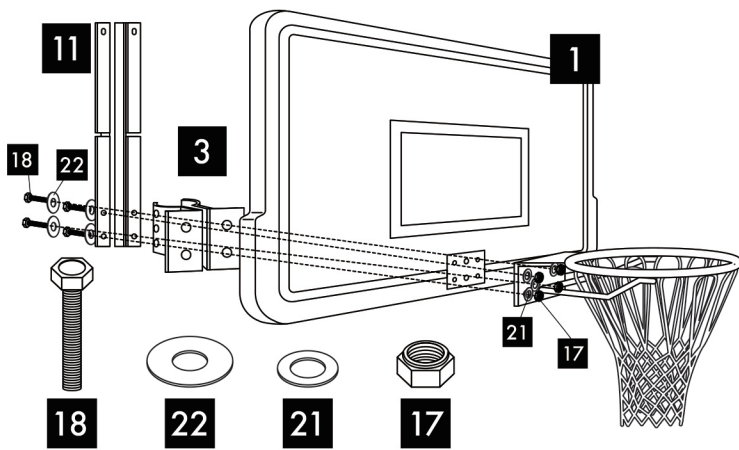

03



19



21

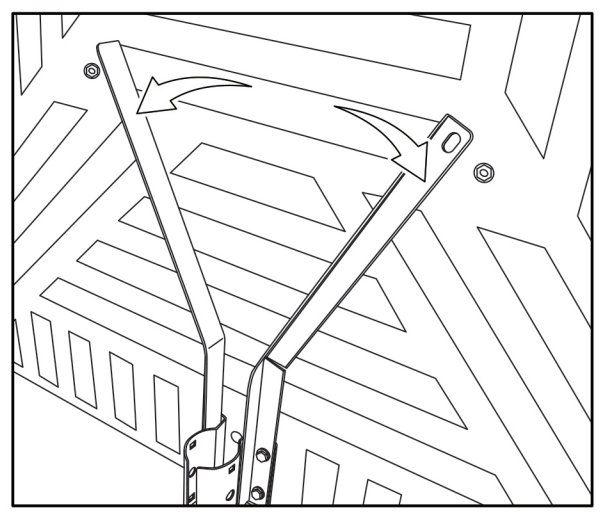
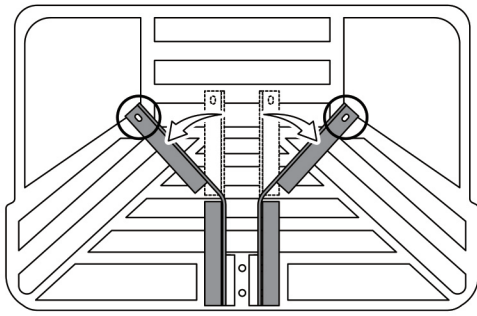

04

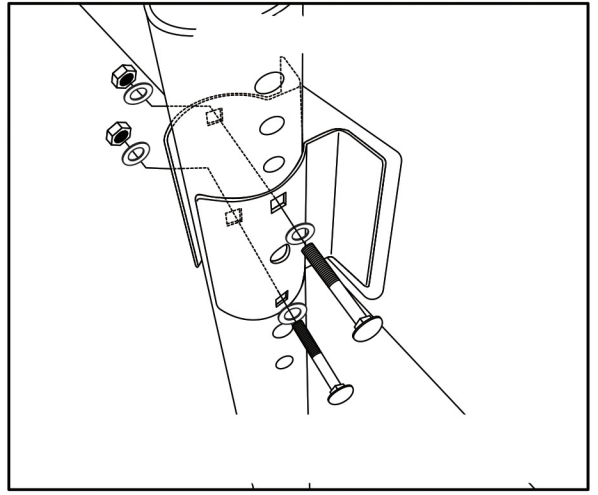
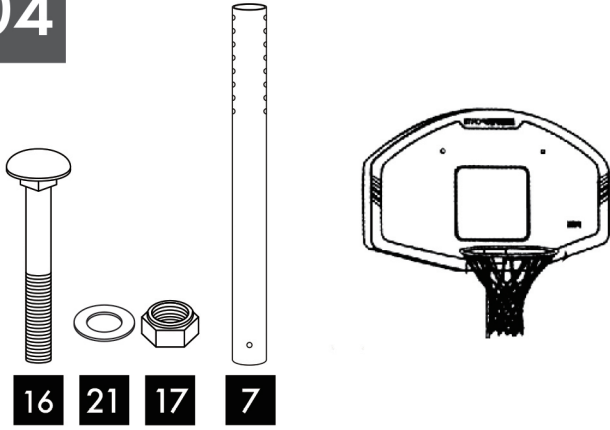

05

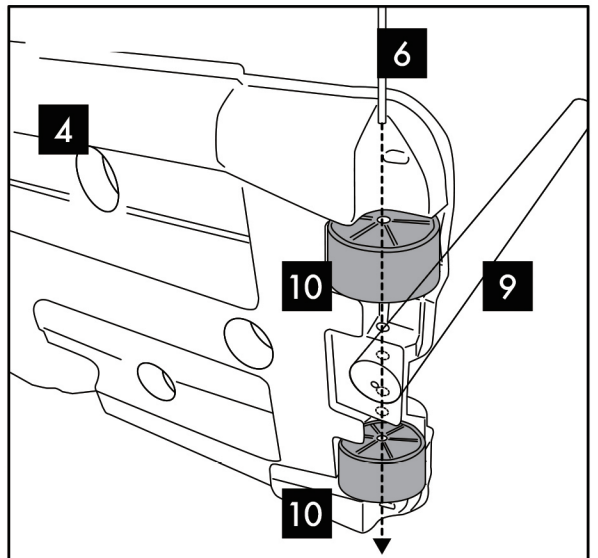
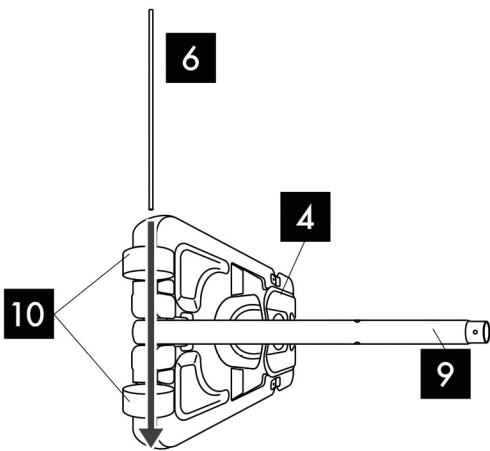

06

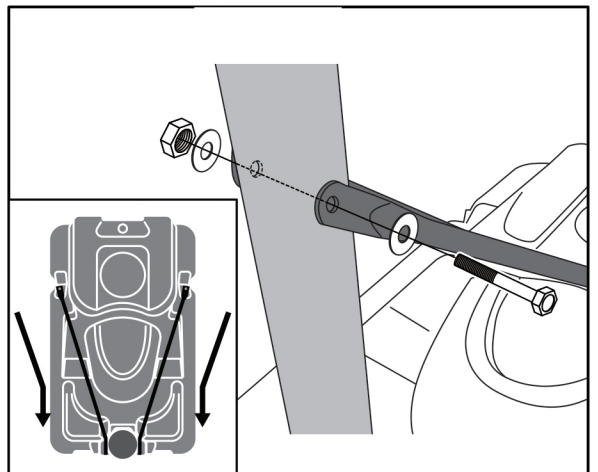
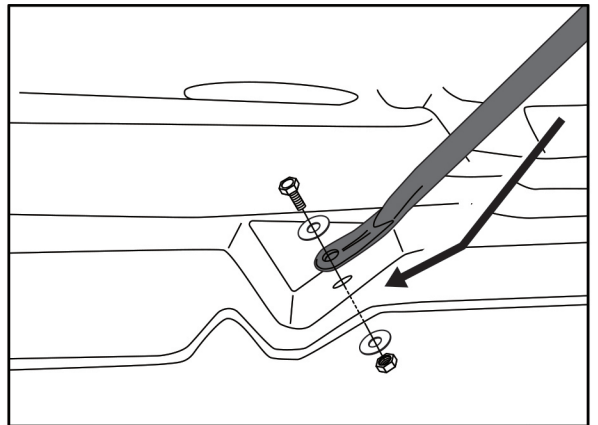
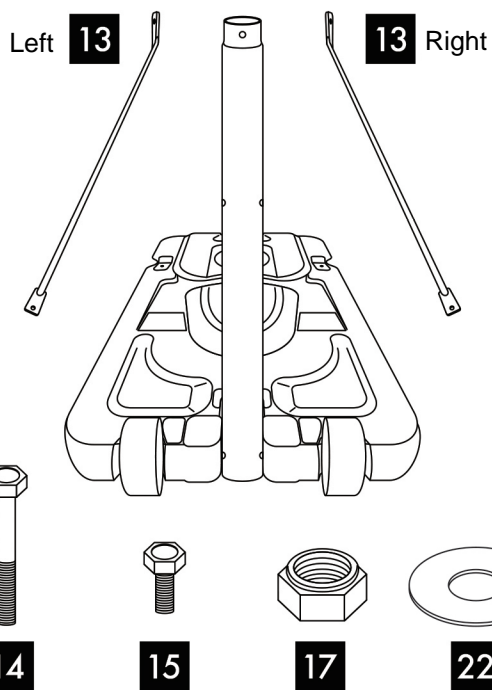

07

