





## HOME GYM





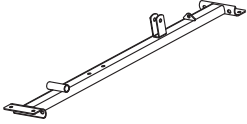

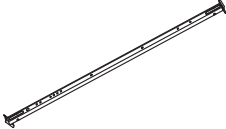
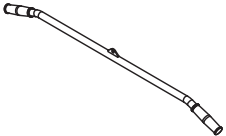

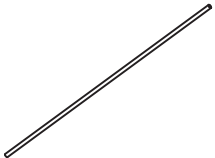
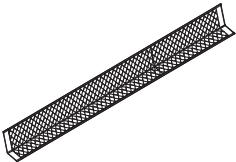
IMPORTANT, RETAIN FOR FUTURE REFERENCE: READ CAREFULLY



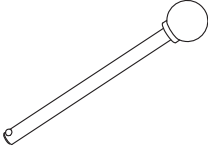

# ASSEMBLY INSTRUCTION

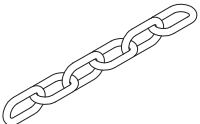
# PACKING DETAILS: TOTAL 4 BOXES

## BOX-1/4

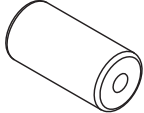
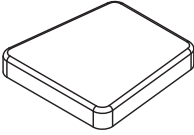
NO.	PARTS	QTY
①		1
④		1
⑤		1
⑭		1
⑳		2
㉒		2
㉓		4

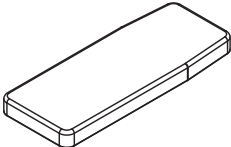

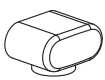

NO.	PARTS	QTY
⑳		1
㉘		2
㉛		1
㉞		14
㉟		6
㊳		5
㊵		2
㊿		2

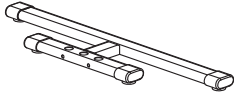
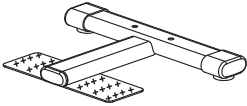
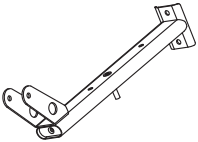
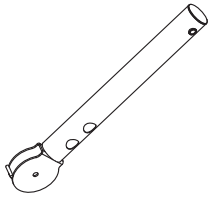
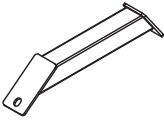
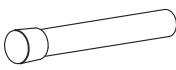
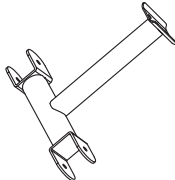
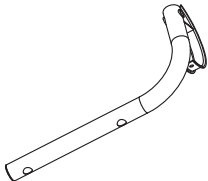
NO.	PARTS	QTY
④②		6
④⑤		4
④⑥		1
④⑦		3
⑤①		1
⑤②		2
⑤④		6
	<b>HARDWARE</b>	1

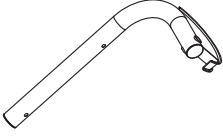
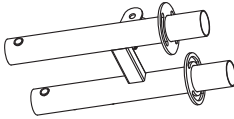
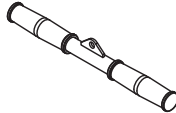
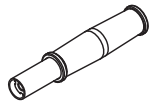
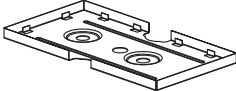
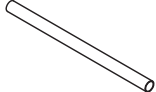
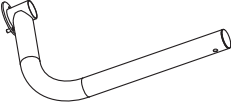
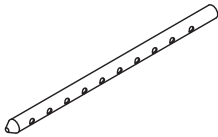
## BOX-2/4

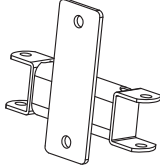
NO.	PARTS	QTY
2		1
3		1
6		1
7		1
8		1
9		1
10		1
11		1

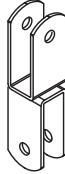
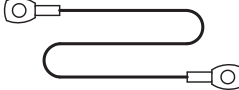
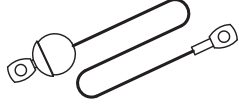
NO.	PARTS	QTY
12		1
13		1
15		1
16		4
17		2
18		2
19		2
21		1

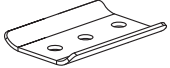
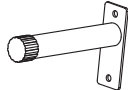
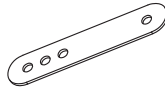
NO.	PARTS	QTY
30		1
32		2
33		1
34		1
39		1
44		1
48		3
51		1
35		2

### BOX-3/4

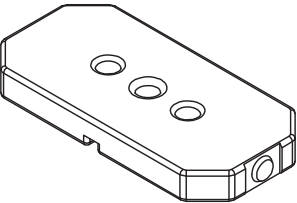
NO.	PARTS	QTY
29		5

### BOX-4/4

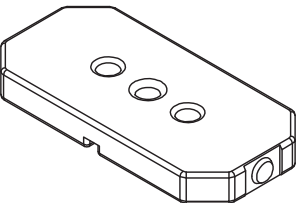
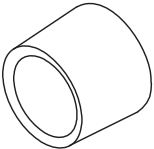
NO.	PARTS	QTY
29		4
49		1

## TABLE OF CONTENTS

SAFETY INFORMATION .....	1
PRODUCT COMPONENT DETAILS .....	3
PARTS LIST .....	4
PARTS LIST 1 .....	5
PARTS LIST 2 .....	6
INSTALLATION .....	7
CLEANING AND MAINTENANCE .....	18
DISPOSAL .....	18

## SAFETY INFORMATION

### **IMPORTANT – Please read fully before assembly or use.**

This exercise equipment is built for optimum safety. However, certain precautions apply whenever you operate a piece of exercise equipment. Be sure to read the entire manual before you assemble, operate, or use this equipment, note the following safety precautions.

#### **Assembly**

- Ensure you have all the parts and tools listed on pages 6-8.
- Remove all fittings from the plastic bags and separate them into their groups.
- Keep children and animals away from the work areas, small parts can cause a choking hazard if swallowed.
- Ensure you have enough space to layout the parts before starting.
- The assembly of this equipment is best carried out by 2 persons.
- Assemble the item as close to its final position (in the same room) as possible.
- The free-standing equipment shall be installed on a stable and level base.
- Dispose of all packaging carefully and responsibly.

#### **Using**

- This weight station is made for training in private environment. Only use the equipment for its intended use.
- **DO NOT** make any changes to the equipment which can affect the security of the product.
- **Warning! Pregnant or physically injured persons should never use the weight station without prior consultation with a doctor you trust.**
- Be aware of your body's signals. Incorrect or excessive exercise can damage your health. **STOP** exercising if you experience any pain, tightness in your chest, irregular heartbeat, extreme shortness of breath, light headedness, dizziness, or nausea. If you do experience any of these conditions you should **CONSULT YOUR DOCTOR IMMEDIATELY** before continuing with your exercise program.
- Always adapt your training style to your personal fitness level and health.
- Before every training session, ensure you check the equipment for operation and safety.
- Before using, ensure the item is installed correctly and that all safety devices are functional! Damages or alterations to the product resulting from modification, will invalidate your warranty. For problems resulting from the modification or other restrictions, the seller is not responsible.
- Any damage must be reported to the seller immediately after delivery, and before use or installation. Later complaints will not be considered.
- Use only suitable tools for assembly.
- The installation must **ONLY** be carried out by adults. Children should not be present in the immediate environment where the assembly is taking place.
- Make sure all connections are securely mounted before releasing the product for use.
- Check all connections at regular intervals for damage, loose elements and other factors that can lead to a loss of sufficient security.
- Do not leave children unattended on the weight bench! It is not a toy! Instruct them not to play with or climb on the appliance.
- In case of a fault during day-to-day use, or during maintenance, lock the bike to prevent any risk of injury.

- Children or persons with limited physical or mental abilities, or those not familiar with this device, should not be allowed to use this weight bench!
- Please keep in mind that this manual and the safety can only draw your attention to eventual hazard. Logical conclusions and care should always be practiced when handling this device.
- Before using the equipment to exercise, always warm up with stretching exercises.
- Before using the equipment, check the nuts and bolts are securely tightened.
- The safety level of the equipment can only be maintained if it is regularly examined for damage and/or wear and tear. If you find any defective components whilst assembling or checking the equipment, or if you hear any unusual sounds, from the equipment during use, STOP! Do not use the equipment until the problem has been rectified.
- Wear suitable clothing whilst using the equipment. Avoid wearing loose clothing which may get caught in the equipment or that may restrict or prevent movement.
- Before starting any exercise or conditioning program you should consult with your personal physician to see if you require a complete physical exam. This is especially important if you are over the age of 35, have never exercised before, are pregnant, or suffer from any illness.
- Use the equipment on a solid, flat surface with a protective cover for your floor or carpet.

PRODUCT COMPONENT DETAILS

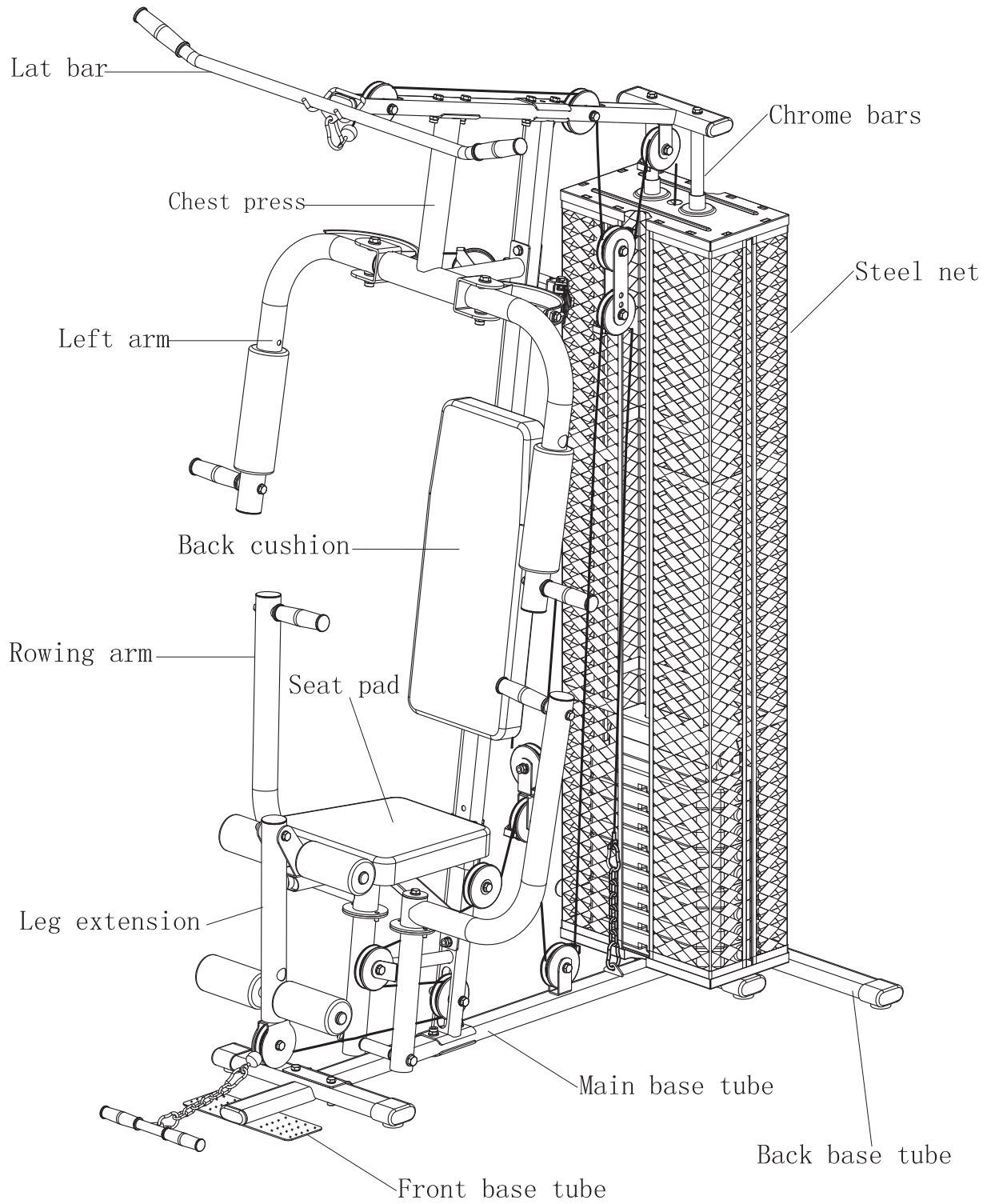











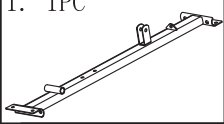
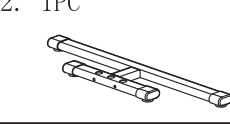
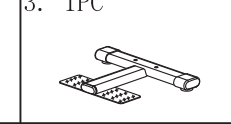
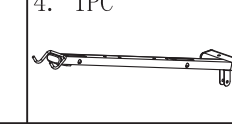
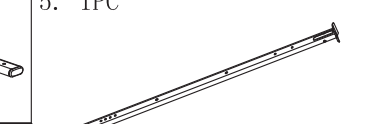
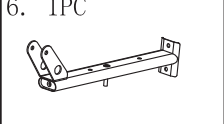
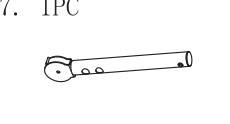
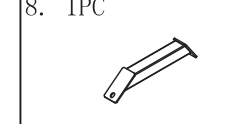
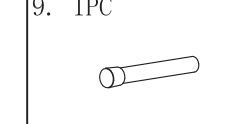
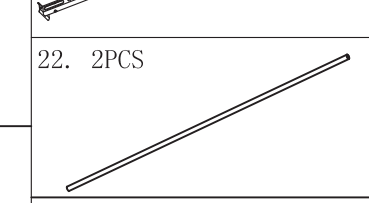
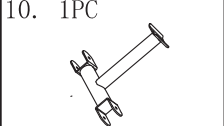
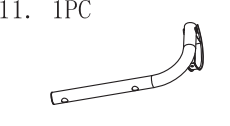
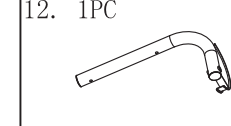
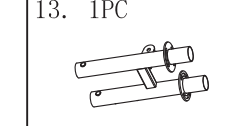
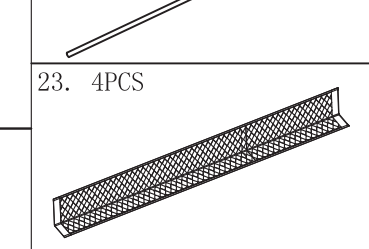
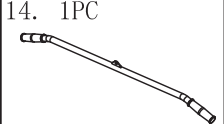

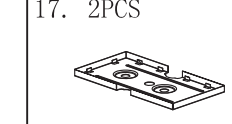
## PARTS LIST

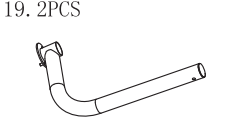
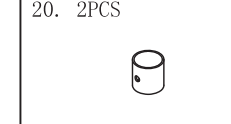
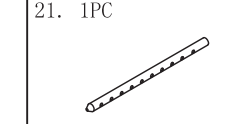
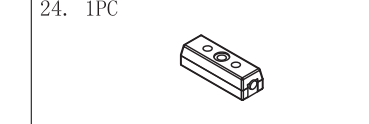
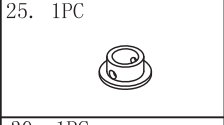
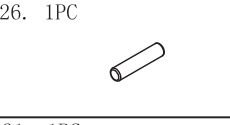
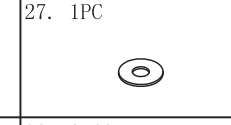
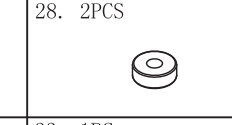
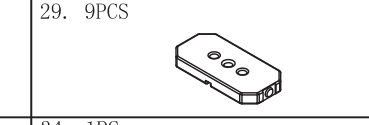
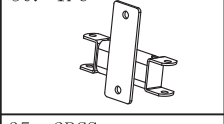
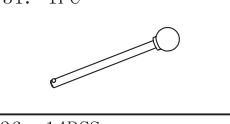
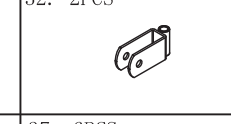
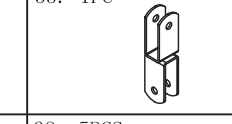
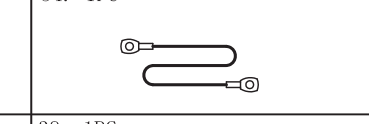
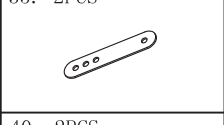
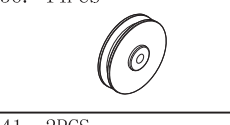
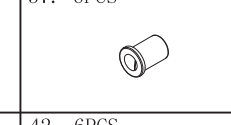

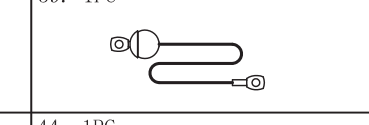
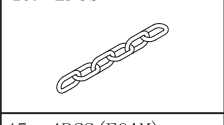
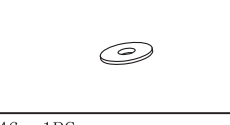
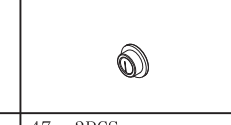
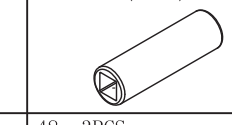
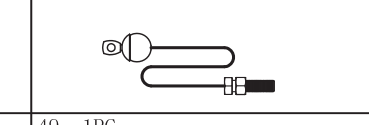
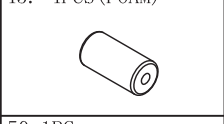
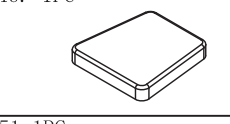
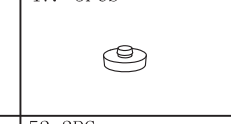
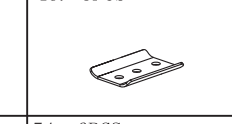
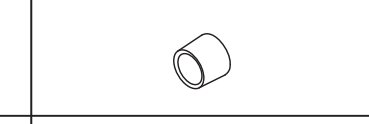
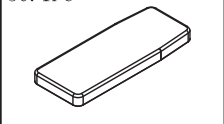











Parts	Description	Qty
1	Main base tube	1 pc
2	Back base tube	1 pc
3	Front base tube	1 pc
4	Upper Support	1 pc
5	Vertical Support	1 pc
6	Seat Support	1 pc
7	Leg Extension	1 pc
8	Reinforced tube	1 pc
9	Rowing support	1 pc
10	Chest press	1 pc
11	Left arm	1 pc
12	Right arm	1 pc
13	"H"-shaped support	1 pc
14	Lat bar	1 pc
15	Curling bar	1 pcs
16	Handle bar	4 pcs
17	Steel plate	2 pcs
18	Foam Tube (370mm)	2 pcs
19	Rowing arm	2 pcs
20	Round holder	2 pc
21	Weight selector	1 pcs
22	Chrome bars (1820mm)	2 pcs
23	Steel net	4 pc
24	Upper Weights	1 pc
25	Weight Block Bushing	1 pc
26	Pin $\Phi$ 10	1 pc
27	Big Washer ( $\Phi$ 45)	1 pc

Parts	Description	Qty
28	Rubber Cushion	2 pcs
29	Weight	9 pcs
30	Pulley shaft	1 pc
31	Locking pin 10*150	1 pc
32	Pulley Seat	2 pcs
33	Pulley bracket	1 pc
34	Cable 1	1 pc
35	Adjusting plate	2 pcs
36	Pulley ( $\Phi$ 90)	14 pcs
37	Pulley bushing	6 pcs
38	Safe hook	5 pcs
39	Cable 2	1 pc
40	Chain	2 pcs
41	Big washer ( $\Phi$ 50)	2 pcs
42	Steel bushing	6 pcs
43	Foam (250mm)	2 pcs
44	Cable 3	1 pc
45	Foam (160mm)	4 pcs
46	Seat pad	1 pc
47	PVC bumper $\Phi$ 30*7	4 pcs
48	Reinforced place (100mm)	3 pcs
49	Rubber bumper	1 pc
50	Back cushion	1 pc
51	Prop support	1 pc
52	Pulley busing ( $\Phi$ 16)	1 pc
54	Foot cover	6 pcs

# PARTS LIST 1

1. 1PC 	2. 1PC 	3. 1PC 	4. 1PC 	5. 1PC 
6. 1PC 	7. 1PC 	8. 1PC 	9. 1PC 	22. 2PCS 
10. 1PC 	11. 1PC 	12. 1PC 	13. 1PC 	23. 4PCS 
14. 1PC 	15. 1PC 	16. 4PCS 	17. 2PCS 	
18. 2PCS 	19. 2PCS 	20. 2PCS 	21. 1PC 	24. 1PC 
25. 1PC 	26. 1PC 	27. 1PC 	28. 2PCS 	29. 9PCS 
30. 1PC 	31. 1PC 	32. 2PCS 	33. 1PC 	34. 1PC 
35. 2PCS 	36. 14PCS 	37. 6PCS 	38. 5PCS 	39. 1PC 
40. 2PCS 	41. 2PCS 	42. 6PCS 	43. 2PCS (FOAM) 	44. 1PC 
45. 4PCS (FOAM) 	46. 1PC 	47. 3PCS 	48. 3PCS 	49. 1PC 
50. 1PC 	51. 1PC 	52. 2PC 	54. 6PCS 	

## PARTS LIST 2

<p>55. 1PC (M12*190)</p> 	<p>69. 1PC (M10*110)</p> 
<p>56. 2PCS (M12*85)</p> 	
<p>57. 3PCS (M10*90)</p> 	
<p>58. 1PC (M10*75)</p> 	
<p>59. 2PCS (M10*60)</p> 	
<p>60. 8PCS (M10*50)</p> 	
<p>61. 13PCS (M10*45)</p> 	
<p>62. 2PCS (M10*40)</p> 	
<p>63. 2PCS (M10*25)</p> 	
<p>64. 11PCS (M10*25)</p> 	
<p>65. 4PCS (M8*45)</p> 	
<p>66. 1PC (M10)</p> 	
<p>67. 4PCS (M8*20)</p> 	
<p>68. 2PCS (M6*16)</p> 	

## INSTALLATION

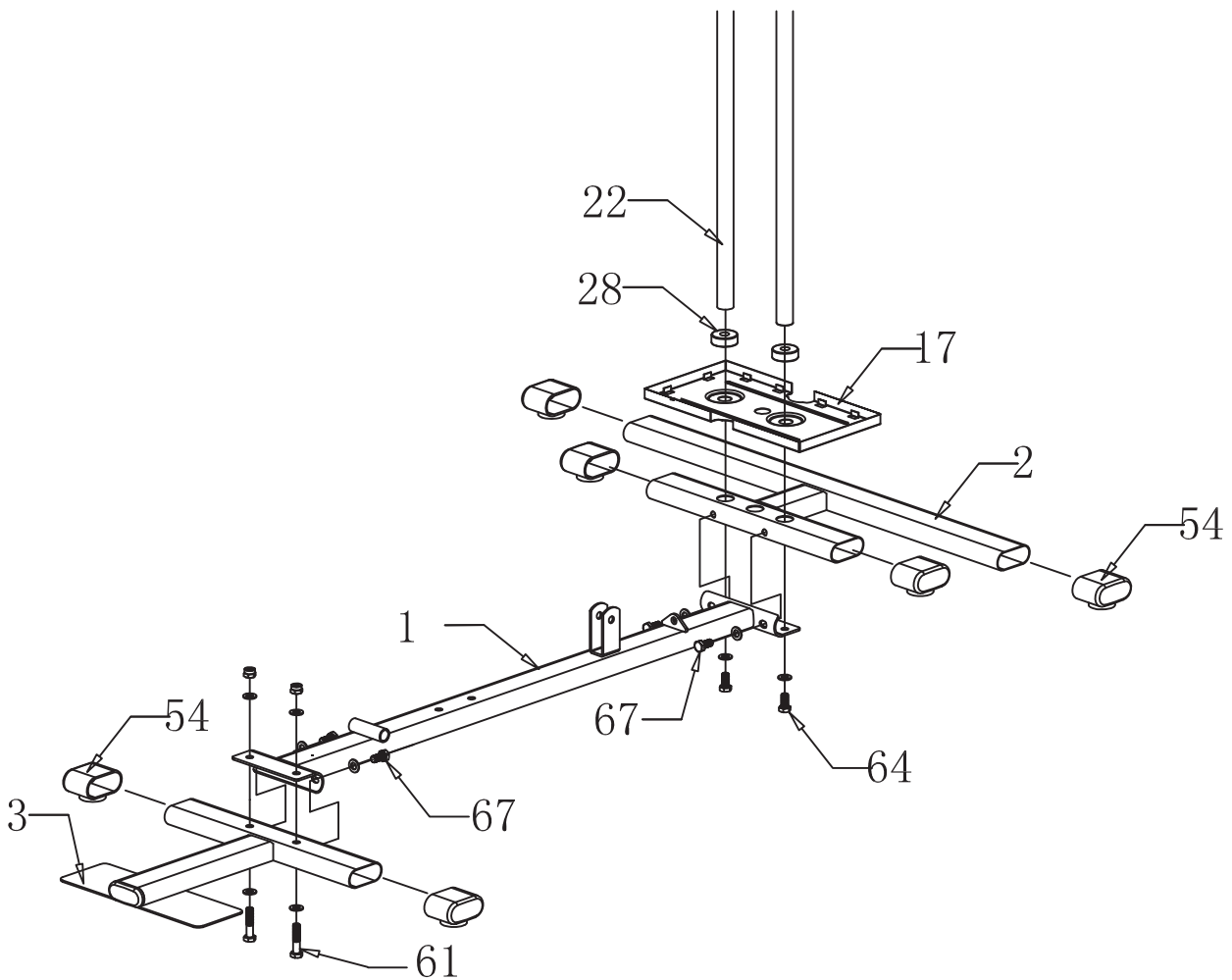

### Step 1

1. Attach main base tube(1) to back base tube(2),chrome bar(22)using Hex bolts M10x25(64- 2sets), washers and Hex bolts M8x20 (67- 2sets),washers.

2. Attach main base tube(1) to front base tube(3)using Hex bolts M10x45(61-2sets), washers, nuts, and Hex bolts M8x20(67-2sets), washers.

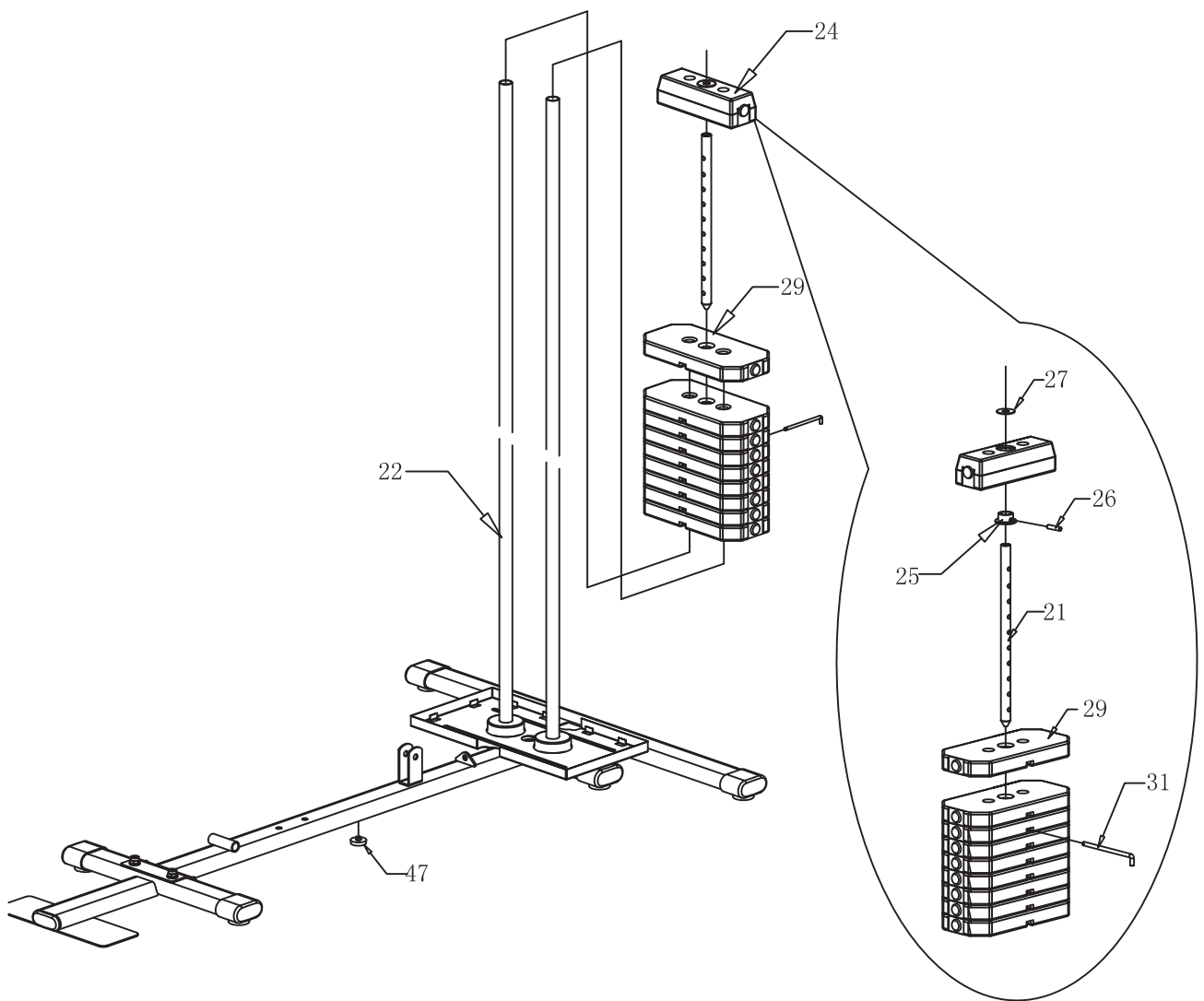

**Step 2**

1. Attach weights(24, 29) to chrome bars(22) as shown.

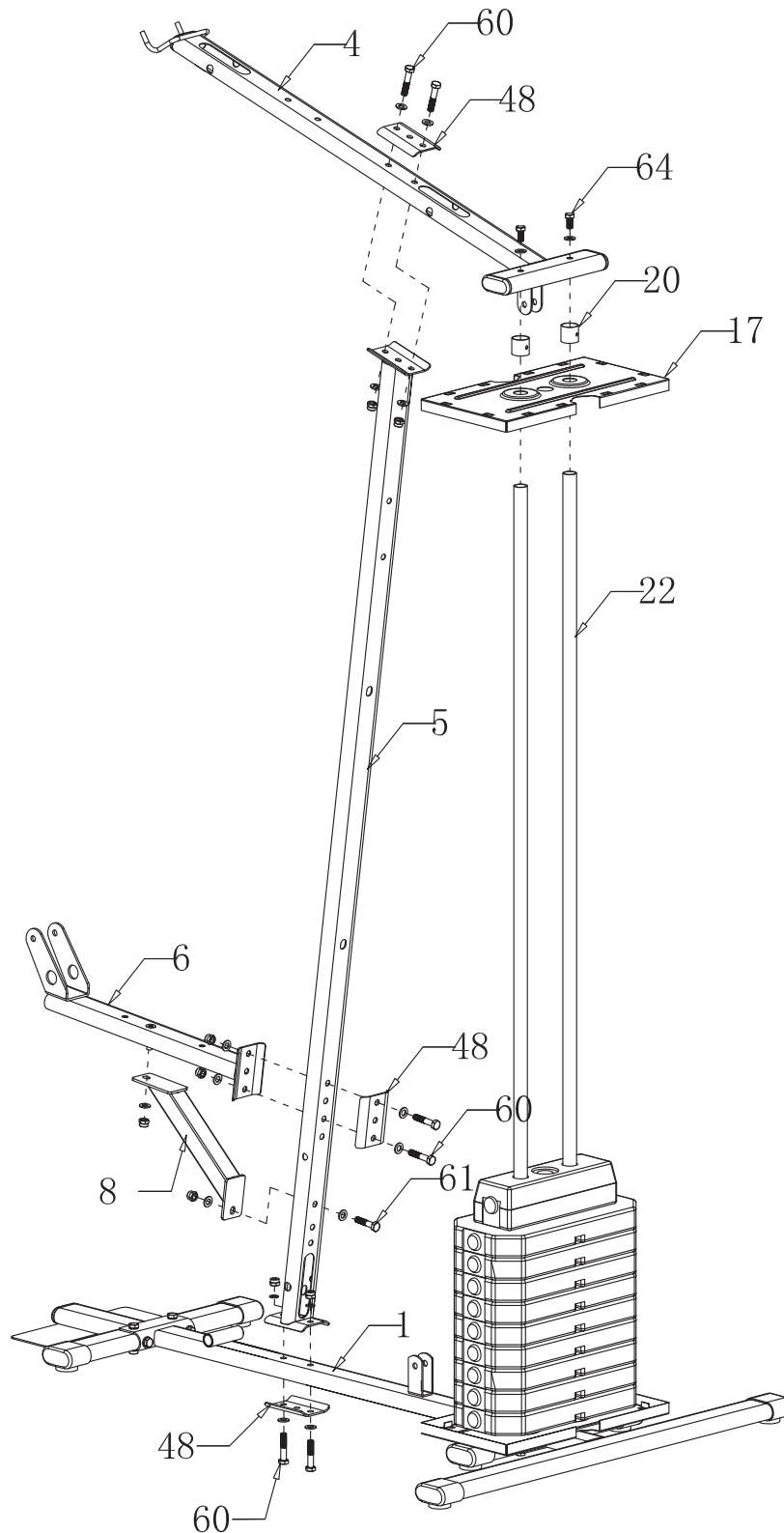

### Step 3

1. Attach Vertical support(5)to Main base tube(1) using reinforced plate (48) and Hex bolts M10 x50 (60-2sets) washers and nuts.
2. Attach Upper support(4)to Vertical support(5) using reinforced plate (48) and Hex bolts M10 x50(60-2sets) and insert chrome bars(22) into holes of upper support(4) using Hex bolts M10 x25(64-2sts).
3. Attach seat support(6), reinforced tube(8) to Vertical support(5) using reinforced plate(48) and Hex bolts M10x50 (60-2sets),bolts M10x45 (61-1 set) washers and nuts.

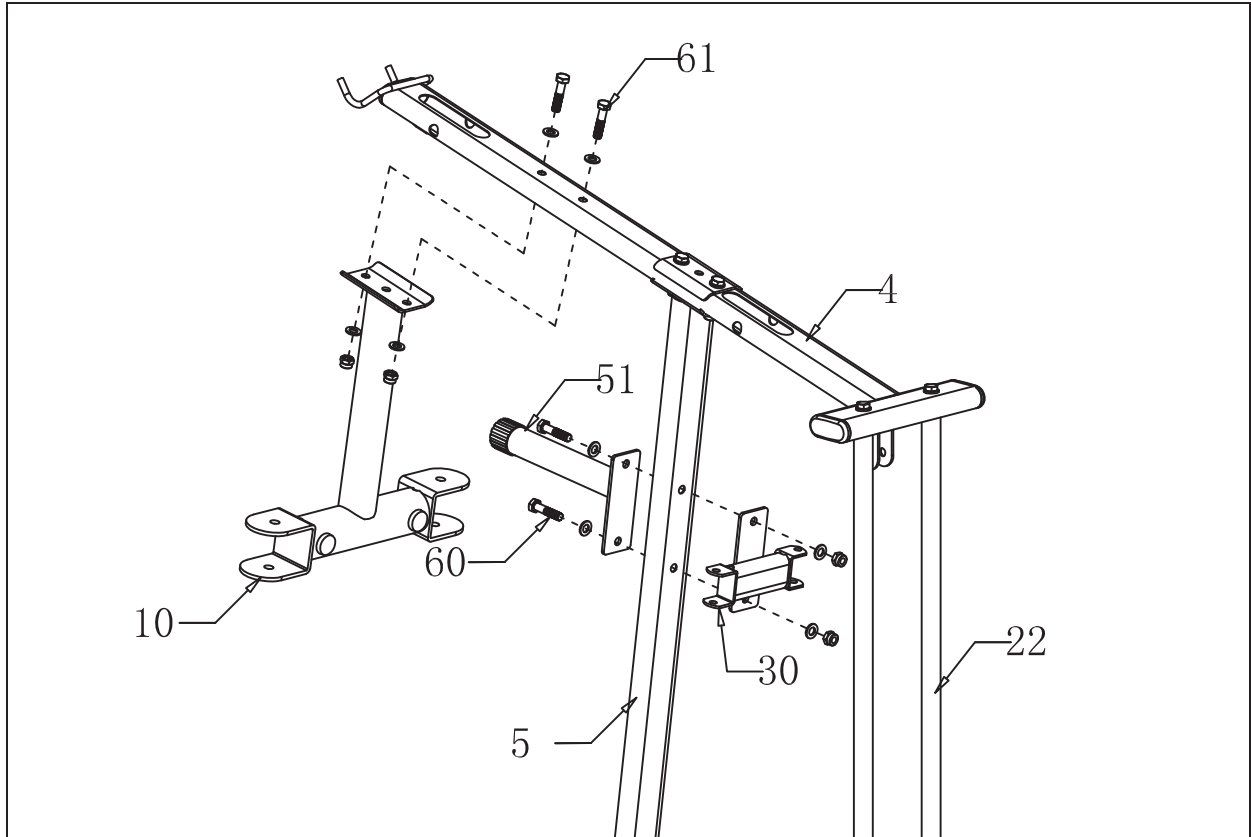

#### Step 4

1. Attach the chest press (10) to upper support (94) using Hex bolts M10 x 45 (61 – 2 sets), washers and nuts

2. Attach the pulley shaft (30), pro support (51) to vertical support (5) using Hex bolts M10 x 50 (51-2sets), washers and nuts

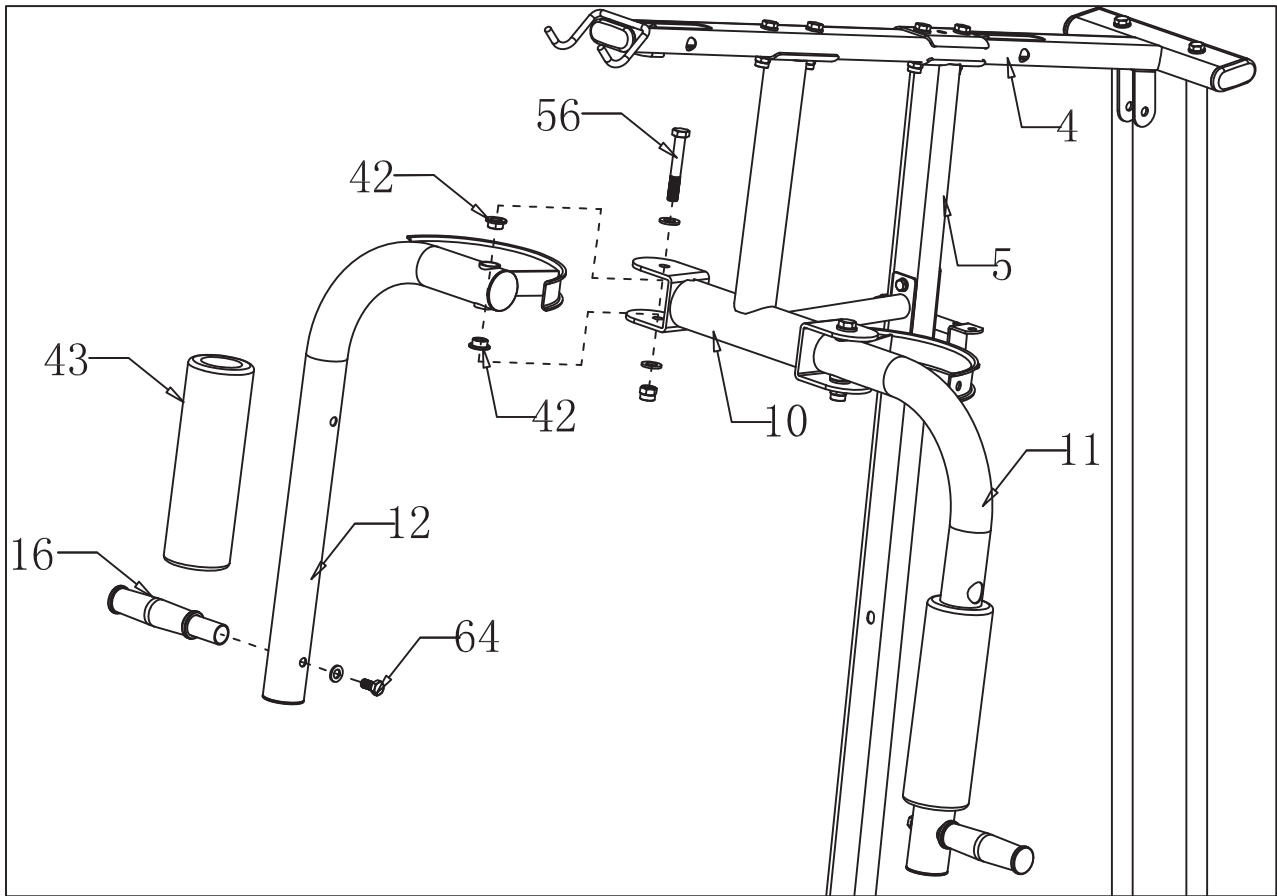

**Step 5**

1. Attach the right arm(12) to chest press(10) using steel bushing (42) and Hex bolts M12x85 (56), washer and nut.

2. Insert the handle bar(16) into right arm(12) using Hex bolts M10x25(64),washer.



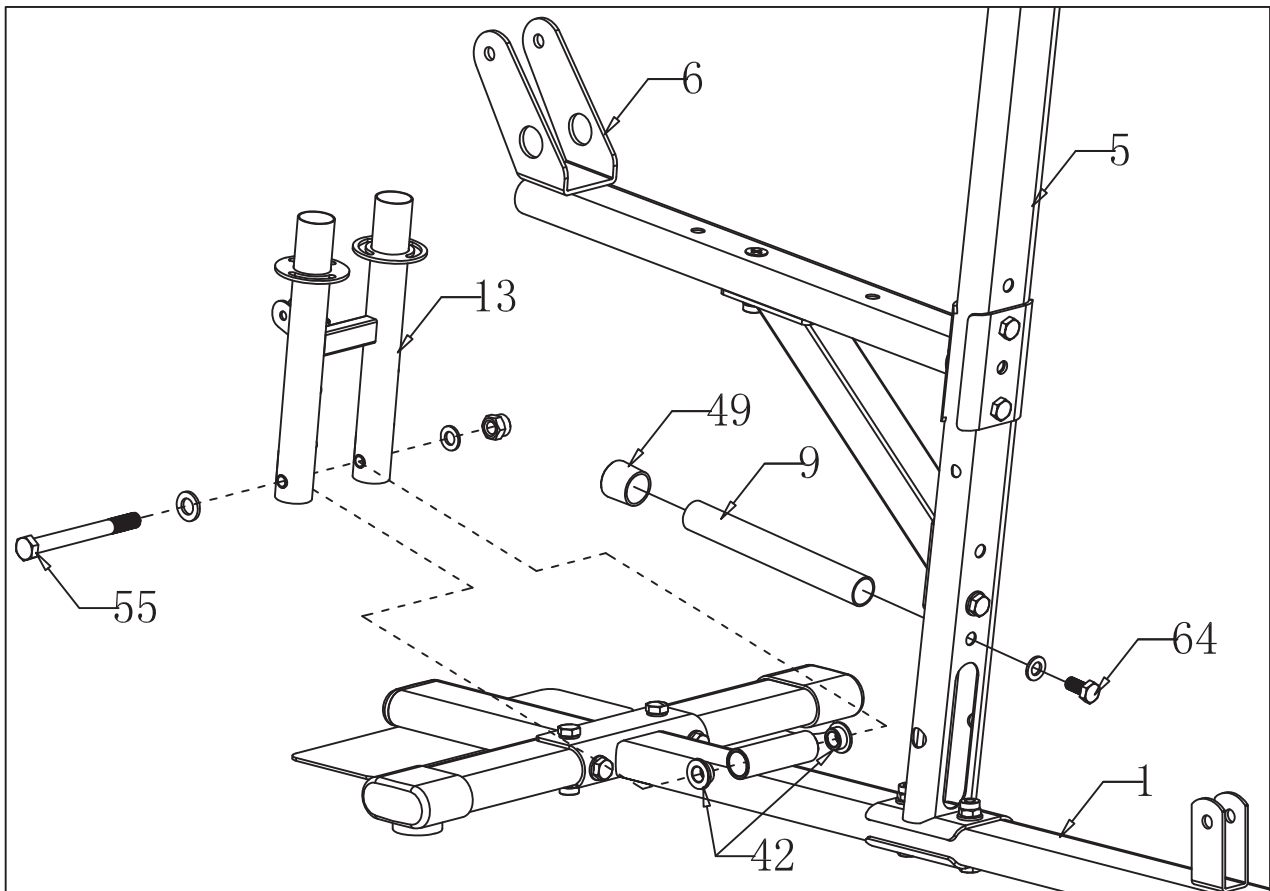

### Step 6

1. Attach the H- shaped support (13) to the main base tube (1) using the steel busing (42) and Hex bolts M12 x 190 (55), washer and nut
2. Insert the rowing support (9) into the holes of the vertical support (5) using Hex bolts M10 x 25 (64), washer

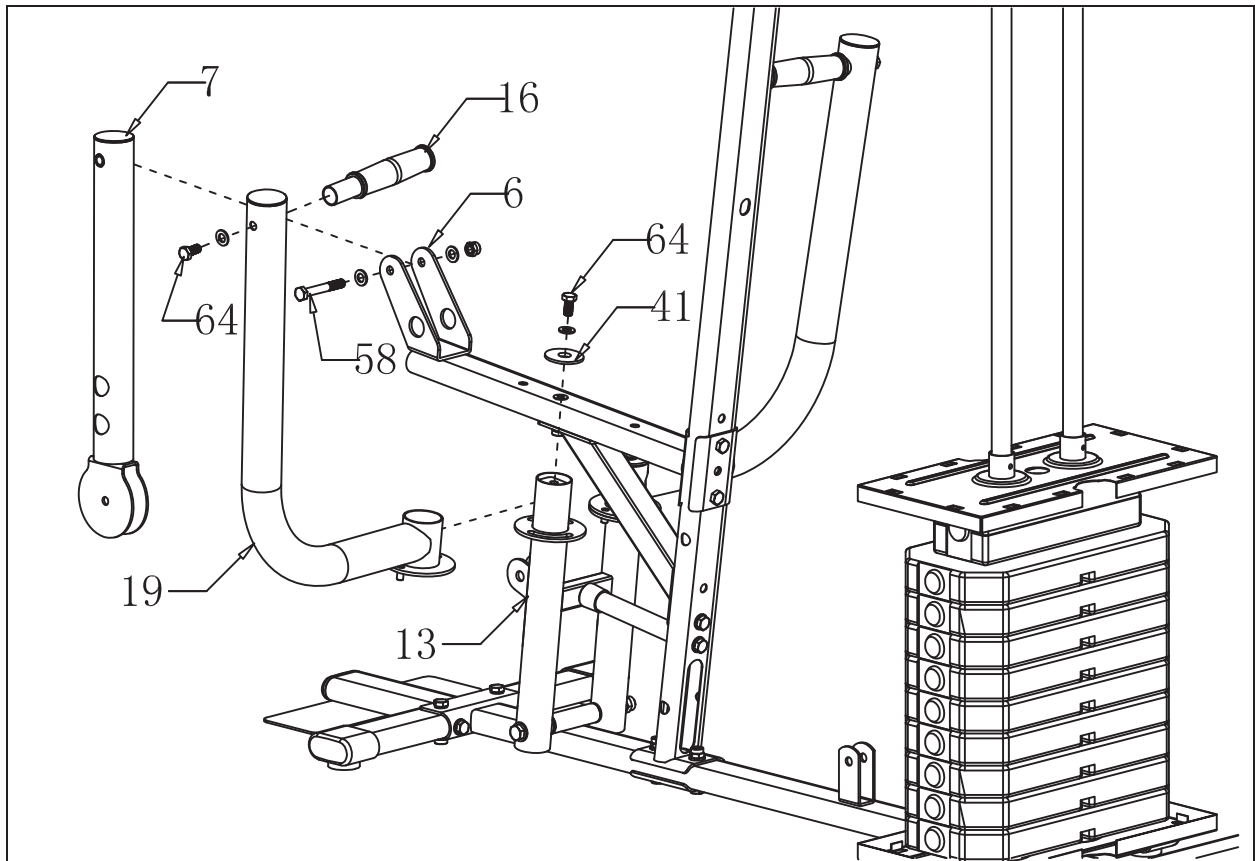

**Step 7:**

1. Attach leg extension(7) to seat support(6) using Hex bolts M10 x75 (58-1sets) washers and nuts.

2. Insert the rowing arm (19) into the H-shaped support (7) using the big washer (41) and Hex bolts M10 x25 (64-2 sets) washers.

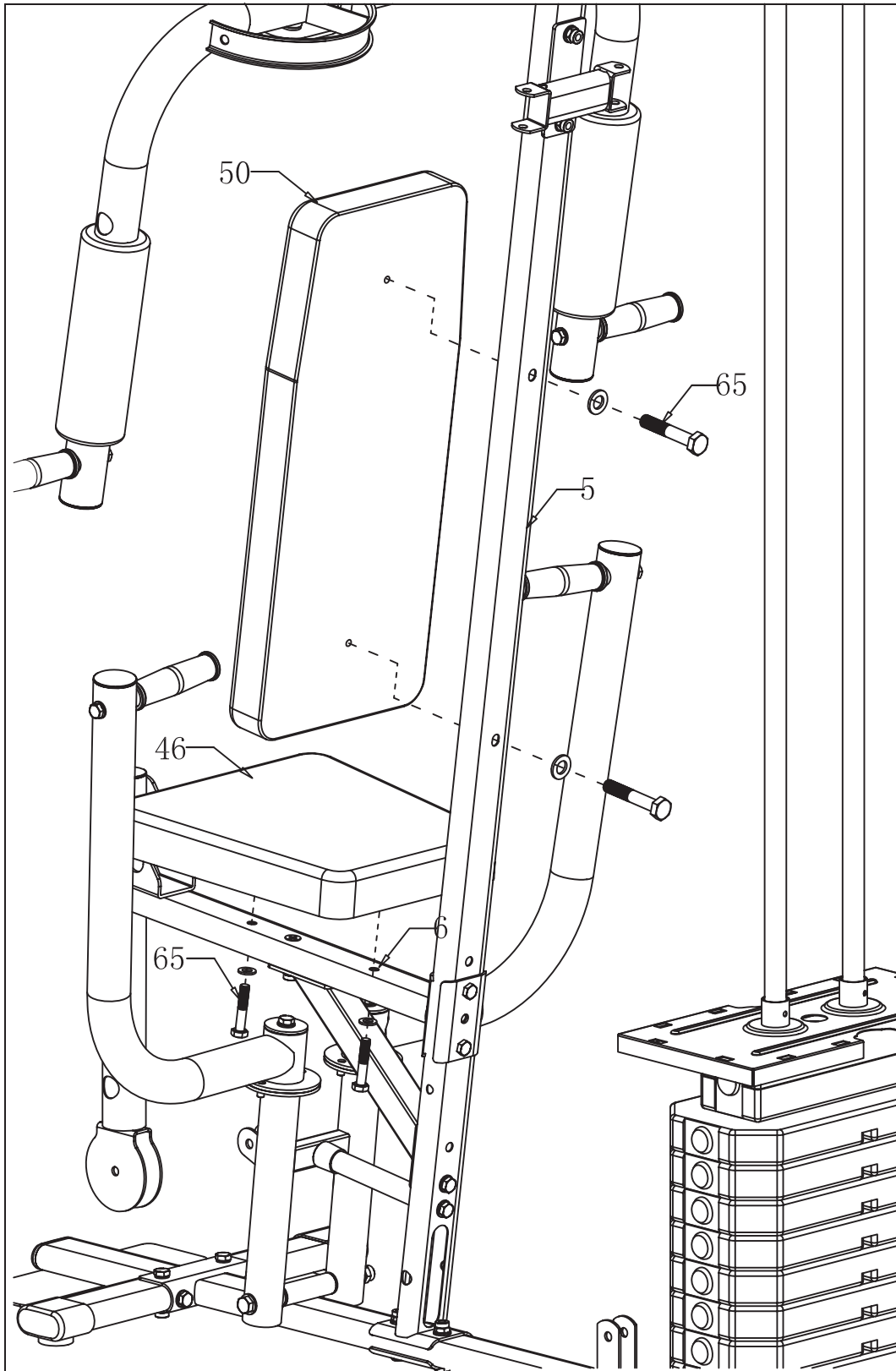

**Step 8:**

1. Attach back cushion(50) to vertical support(5) using Hex bolts M8x45(65-2sets) washers .

2. Attach seat pad (46) to seat support (6) using Hex bolts M8x45 (65-2sets) washers

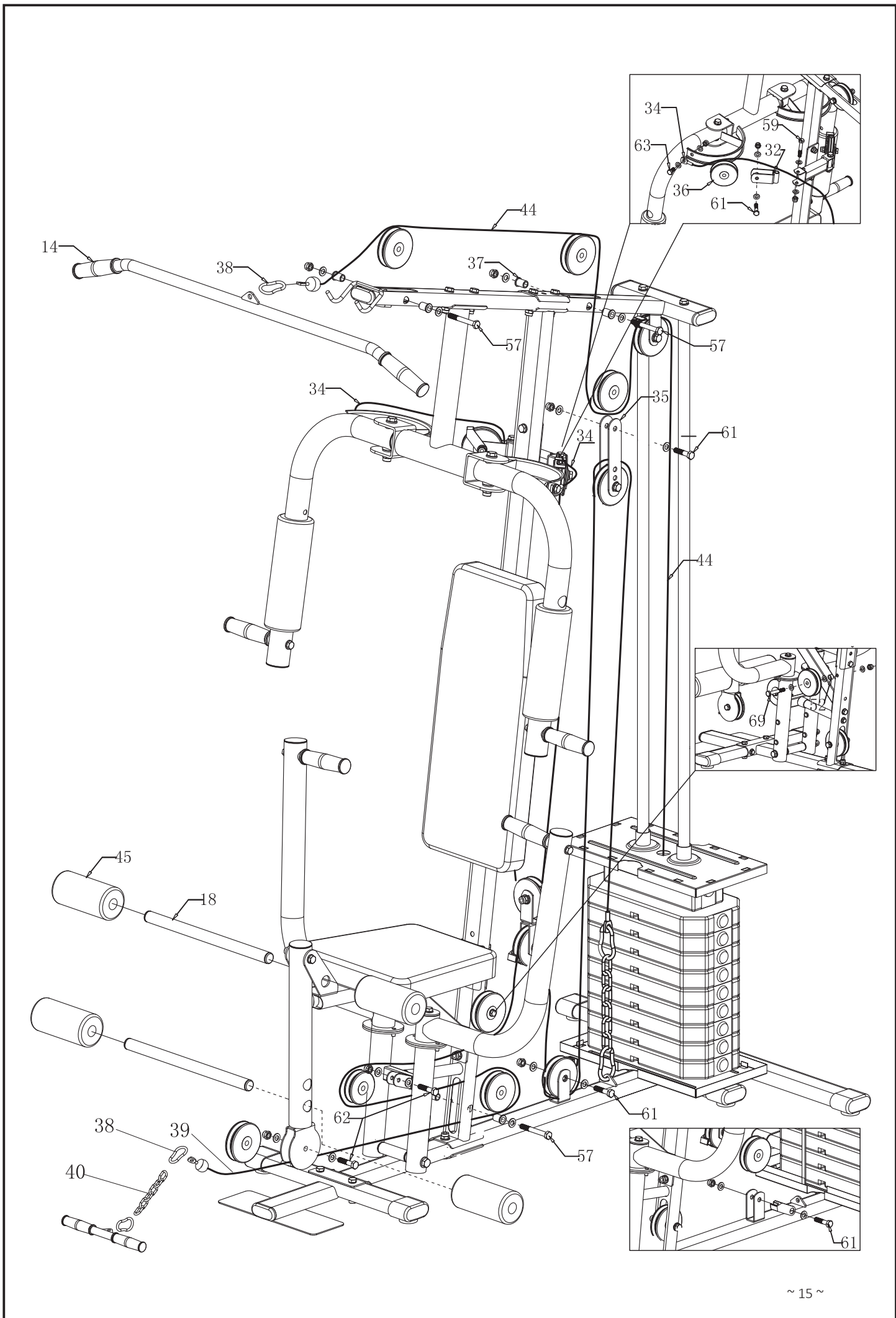

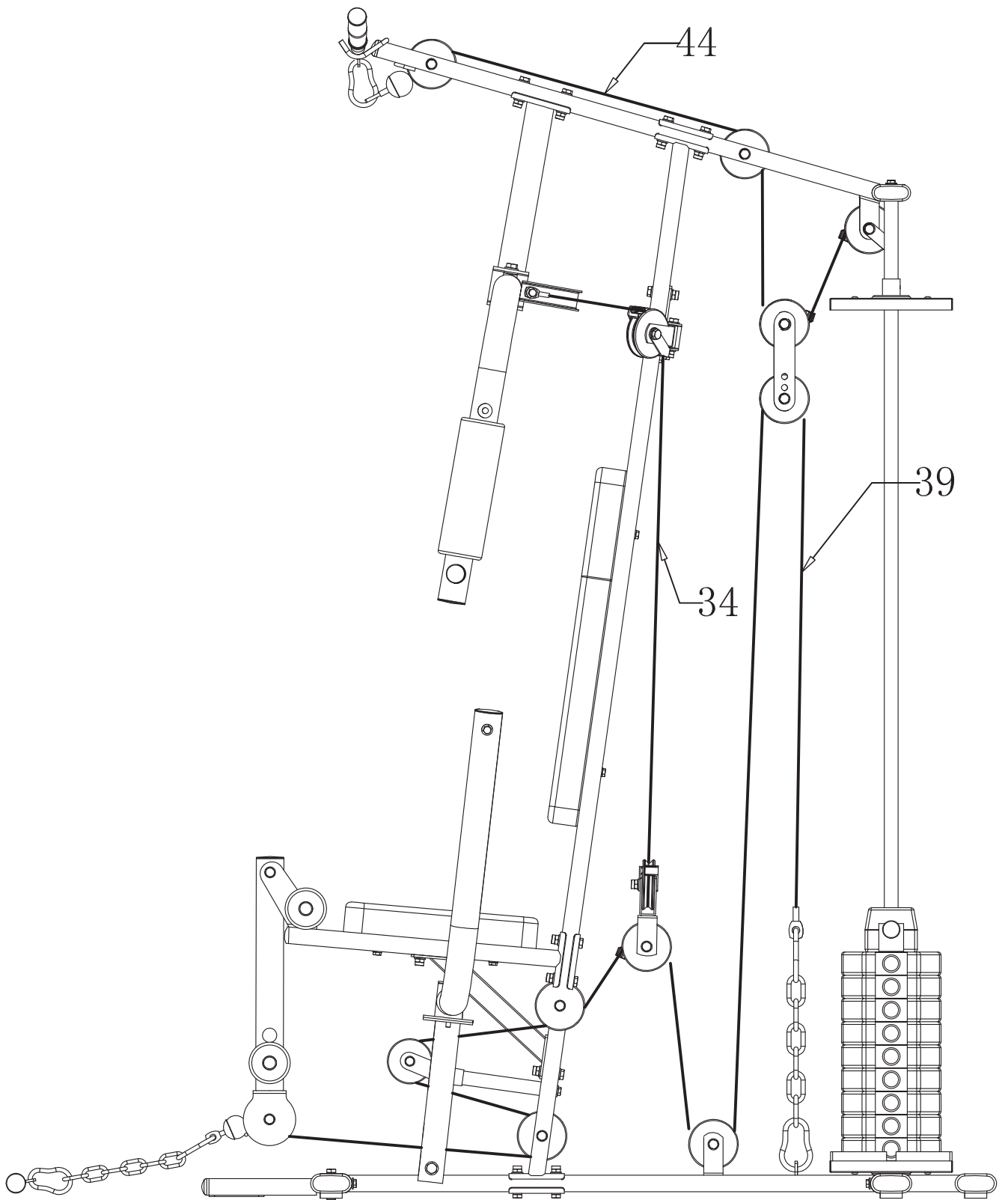

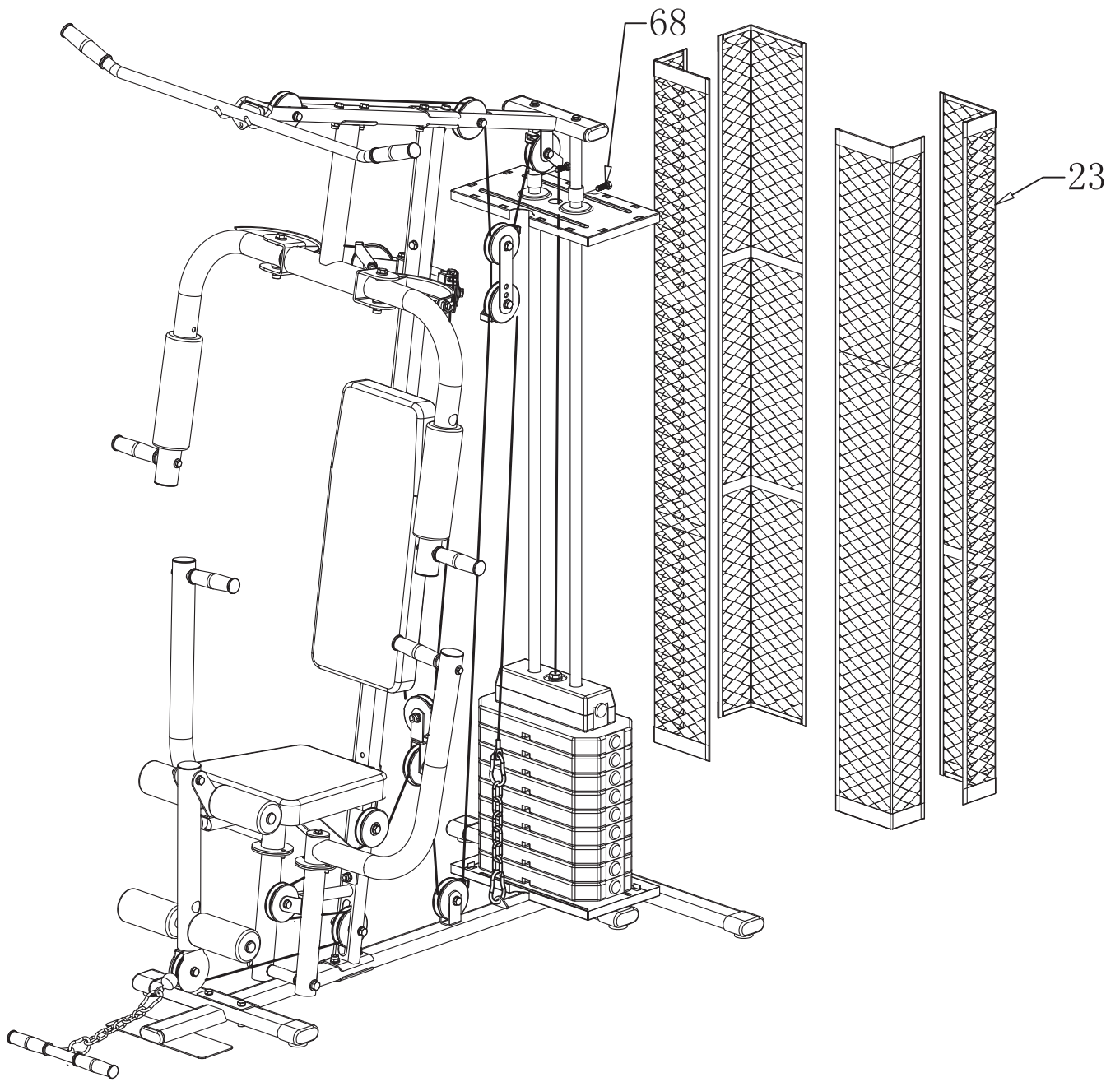

## CLEANING AND MAINTENANCE

1. Regularly examine the equipment to detect any damage to wear which may have occurred. The safety level of the equipment can be maintained only if it is examined regularly for damage and wear and tear on ropes, pulleys, and connection points.
2. Lubricate moving parts with light oil periodically to prevent premature wear.
3. Inspect and tighten all parts before using the equipment. Replace defective components immediately and/or keep the equipment out of use until repair. Pay particular attention to components most susceptible to wear.
4. The equipment can be cleaned using a soft, damp cloth. **Do not** use solvents or abrasive cleaners.

## DISPOSAL



According to the European waste regulation 2012/19/EU this symbol on the product or on its packaging indicates that this product may not be treated as household waste. Instead, it should be taken to the appropriate collection point for the recycling of electrical and electronic equipment. By ensuring this product is disposed of correctly, you will help prevent potential negative consequences for the environment and human health, which could otherwise be caused by inappropriate waste handling of this product. For more detailed information about recycling of this product, please contact your local council or your household waste disposal service.

# ÉQUIPEMENT DE SPORT (GYM) POUR MANUEL D'UTILISATION

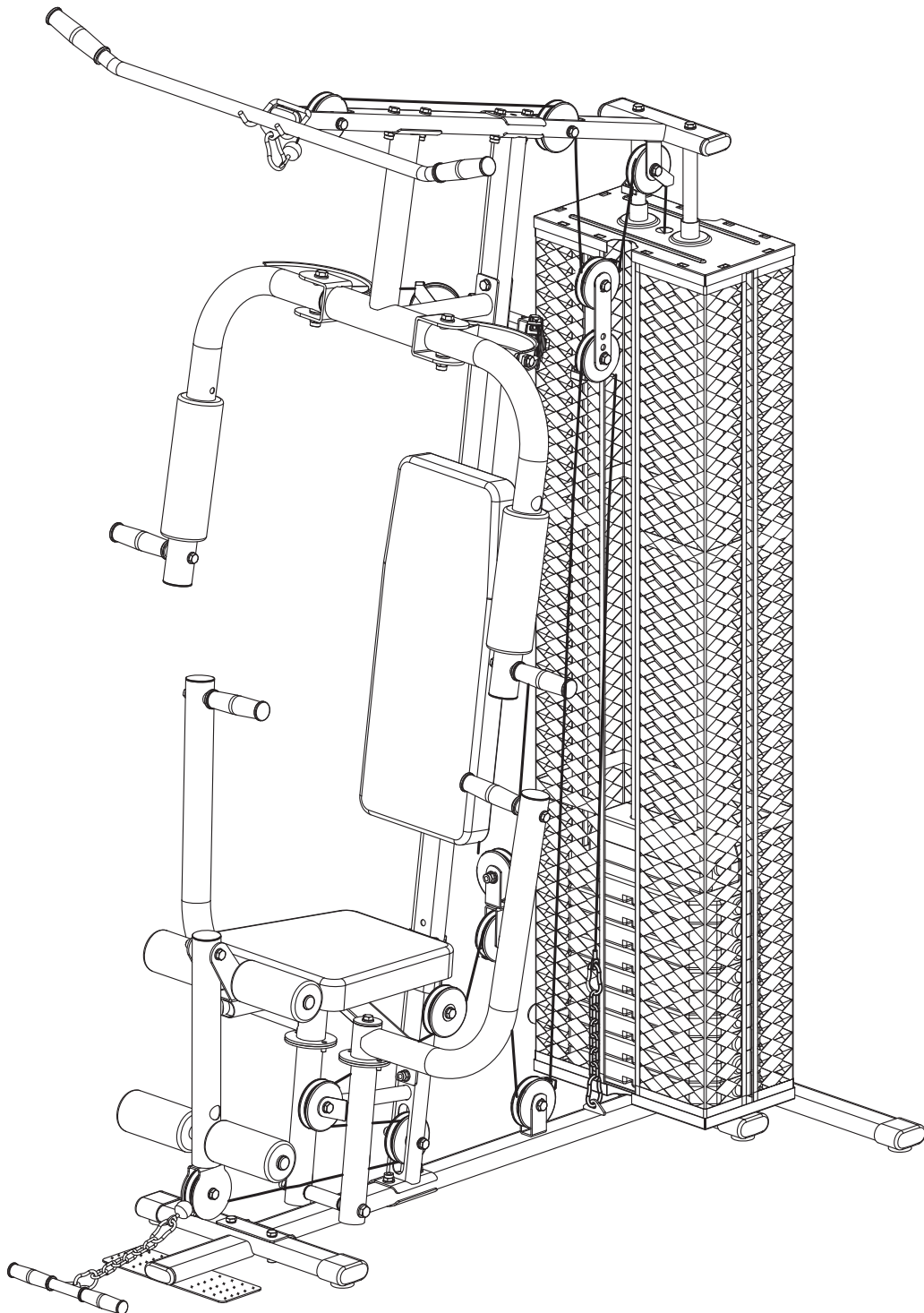



## TABLE DES MATIERES

CONSIGNES DE SÉCURITÉ.....	1
DÉTAIL DES COMPOSANTS DU PRODUIT.....	3
LISTE DE PIÈCES .....	4
LISTE DE PIÈCES 1 .....	5
LISTE DE PIÈCES 2 .....	6
INSTALLATION .....	7
NETTOYAGE ET ENTRETIEN.....	18
MISE AU REBUT.....	18

## CONSIGNES DE SÉCURITÉ

**IMPORTANT - Veuillez lire attentivement ce document avant de procéder à l'assemblage ou à l'utilisation de ce produit.**

Cet équipement d'exercice est construit pour offrir une sécurité optimale. Cependant, certaines précautions s'appliquent chaque fois que vous utilisez un appareil d'exercice. Veuillez à lire l'intégralité du manuel avant d'assembler, de faire fonctionner ou d'utiliser cet équipement, et prenez note des précautions de sécurité suivantes.

### Assemblage

- Assurez-vous d'avoir toutes les pièces et tous les outils énumérés aux pages 6-8.
- Retirez tous les accessoires des sacs en plastique et séparez-les en fonction de leur groupe.
- Tenez les enfants et les animaux à l'écart des zones de travail, les petites pièces pouvant présenter un risque d'étouffement en cas d'ingestion.
- Assurez-vous d'avoir suffisamment d'espace pour disposer les pièces avant de commencer.
- L'assemblage de cet équipement doit être effectué de préférence par 2 personnes.
- Assemblez l'article aussi près que possible de sa position finale (dans la même pièce).
- L'équipement autoportant doit être installé sur une base stable et de niveau.
- Éliminez tous les emballages avec soin et de manière responsable.

### Utilisation

- Cette station de musculation est conçue pour un entraînement dans un environnement privé. N'utilisez l'équipement que pour l'usage auquel il est destiné.
- **NE PAS** apporter de modifications à l'équipement qui pourraient affecter la sécurité du produit.
- **Avertissement! Les personnes enceintes ou physiquement blessées ne doivent jamais utiliser la station de musculation sans avoir consulté au préalable un médecin de confiance.**
- Soyez attentif aux signaux de votre corps. Un exercice incorrect ou excessif peut nuire à votre santé. **ARRÊTEZ** l'exercice si vous ressentez une douleur, une oppression dans la poitrine, un rythme cardiaque irrégulier, un essoufflement extrême, des étourdissements, des vertiges ou des nausées. Si vous ressentez l'un de ces symptômes, **CONSULTEZ IMMÉDIATEMENT VOTRE MÉDECIN** avant de poursuivre votre programme d'exercices.
- Adaptez toujours votre style d'entraînement à votre niveau de forme et à votre état de santé.
- Avant chaque séance d'entraînement, assurez-vous de vérifier le fonctionnement et la sécurité de l'équipement.
- Avant de l'utiliser, assurez-vous que le produit est correctement installé et que tous les dispositifs de sécurité sont fonctionnels! Les dommages ou les altérations du produit résultant d'une modification, annuleront votre garantie. Pour les problèmes résultant de la modification ou d'autres restrictions, le vendeur n'est pas responsable.
- Tout dommage doit être signalé au vendeur immédiatement après la livraison, et avant l'utilisation ou l'installation. Les réclamations ultérieures ne seront pas prises en compte.
- N'utilisez que des outils appropriés pour le montage.
- L'installation doit être effectuée **UNIQUEMENT** par des adultes. Les enfants ne doivent pas être présents dans l'environnement immédiat où le montage a lieu.
- Assurez-vous que toutes les connexions sont solidement montées avant de mettre le produit en service.

- Die Installation darf NUR von Erwachsenen durchgeführt werden. Kinder sollten sich nicht im unmittelbaren Montageumfeld befinden.
- Vergewissern Sie sich, dass alle Anschlüsse sicher montiert sind, bevor Sie das Gerät zur Verwendung freigeben.
- Überprüfen Sie alle Anschlüsse in regelmäßigen Abständen auf Beschädigungen, lose Elemente und andere Faktoren, welche die Sicherheit beeinträchtigen können.
- Lassen Sie Kinder nicht unbeaufsichtigt auf der Hantelbank! Es ist kein Spielzeug! Weisen Sie sie an, nicht mit dem Gerät zu spielen oder darauf zu klettern.
- Sperren Sie das Fahrrad im Falle einer Fehlfunktion im täglichen Gebrauch oder bei Wartungsarbeiten ab, um eine Verletzungsgefahr zu vermeiden.
- Kinder oder Personen mit eingeschränkten körperlichen oder geistigen Fähigkeiten bzw. Personen, die nicht mit diesem Gerät vertraut sind, dürfen diese Hantelbank nicht benutzen!
- Beachten Sie, dass dieses Handbuch und die Sicherheitshinweise Sie nur auf eventuelle Risiken hinweisen können. Beim Umgang mit diesem Gerät lassen Sie stets die Vernunft und Sorgfalt walten.
- Führen Sie vor dem Training mit dem Gerät immer Dehnungsübungen aus, um sich aufzuwärmen.
- Prüfen Sie vor der Verwendung des Geräts, ob die Muttern und Schrauben fest angezogen sind.
- Das Sicherheitsniveau des Geräts kann nur aufrechterhalten werden, wenn es regelmäßig auf Schäden und/oder Verschleiß überprüft wird. Wenn Sie bei der Montage oder Überprüfung des Geräts defekte Teile feststellen oder das Gerät während des Betriebs ungewöhnliche Geräusche erzeugt, UNTERBRECHEN SIE! Verwenden Sie das Gerät erst wieder, sobald das Problem behoben wurde.
- Tragen Sie bei der Verwendung des Geräts angemessene Bekleidung. Vermeiden Sie das Tragen von loser Kleidung, das sich in den Geräten verfangen oder die Bewegung einschränken oder verhindern kann.
- Bevor Sie mit einem Trainings- oder Konditionsprogramm beginnen, sollten Sie Ihren persönlichen Arzt konsultieren, um festzustellen, ob Sie eine vollständige körperliche Untersuchung benötigen. Dies ist besonders wichtig, wenn Sie über 35 Jahre alt sind, noch nie trainiert haben, schwanger sind oder an einer Krankheit leiden.
- Verwenden Sie das Gerät auf einer festen, ebenen Fläche mit einer Schutzabdeckung für Ihren Fußboden oder Teppich.

## DÉTAIL DES COMPOSANTS DU PRODUIT

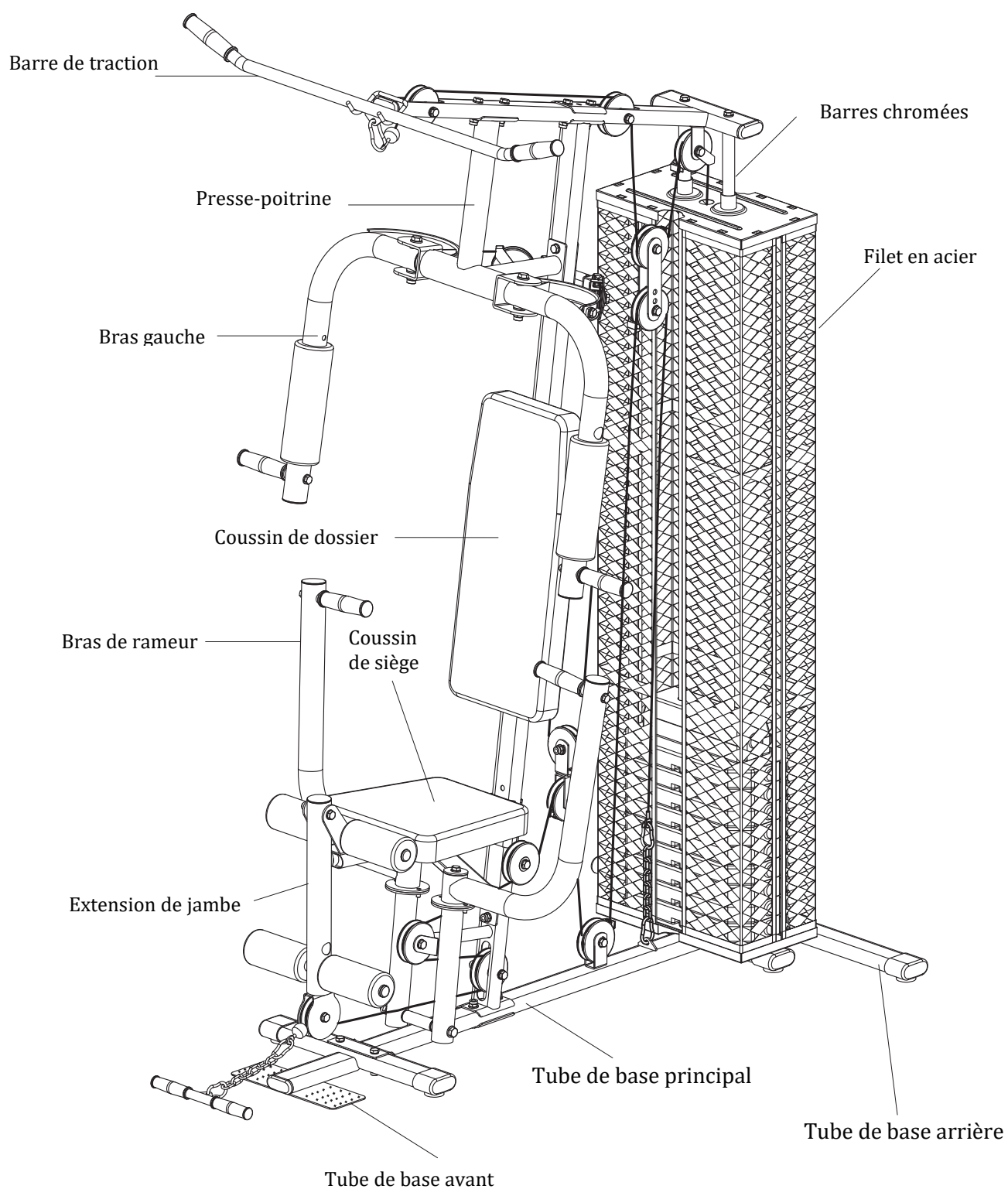









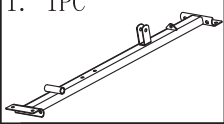
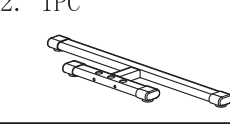
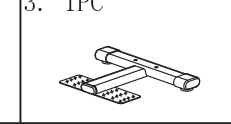
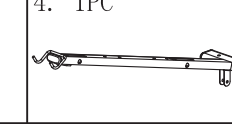
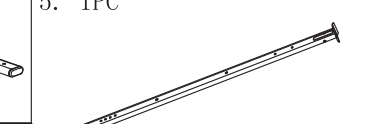
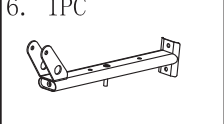
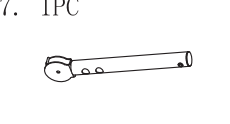
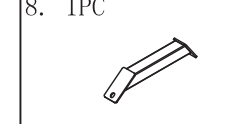
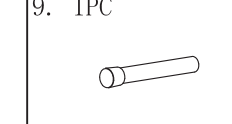
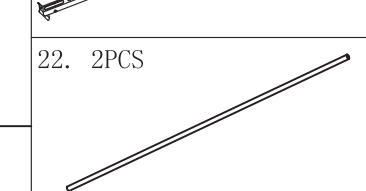
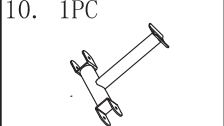
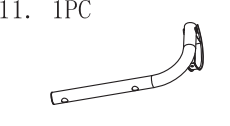
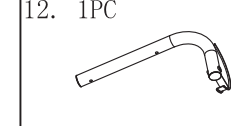
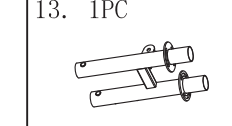
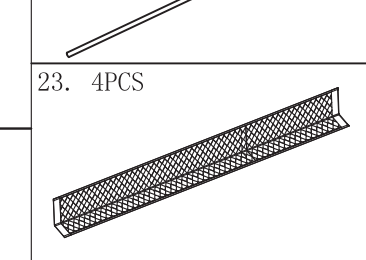
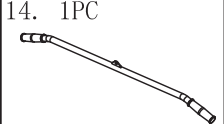

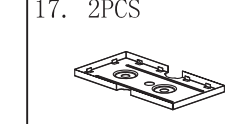
## LISTE DES PIÈCES

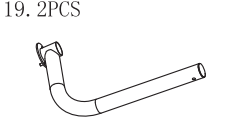
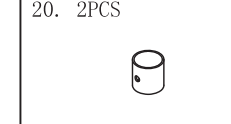
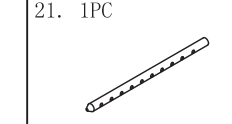
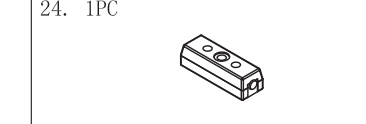
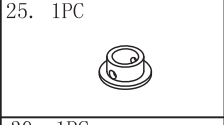
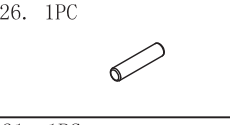
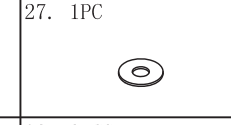
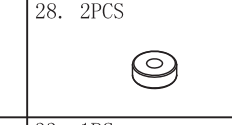
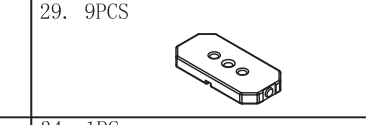
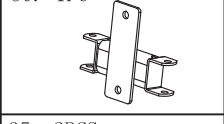
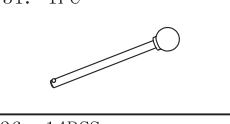
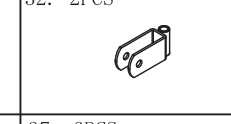
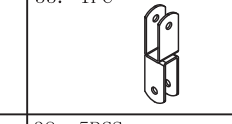
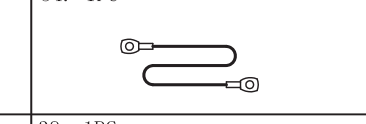
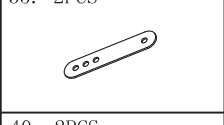
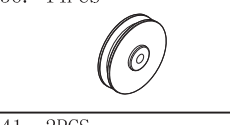
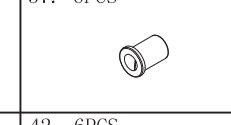

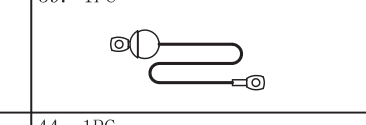

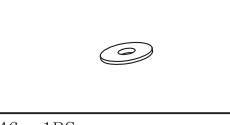
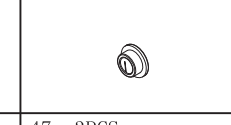
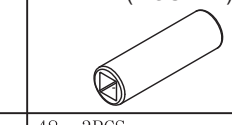
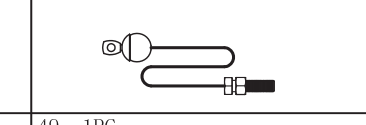
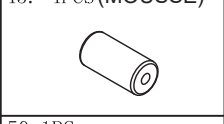
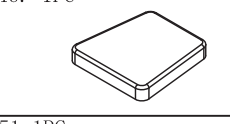
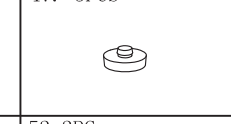
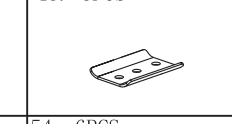
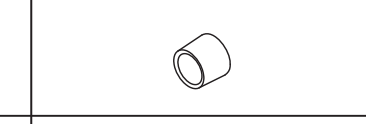
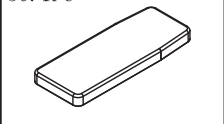

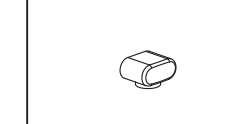







Pièces	Description	Qté
1	Tube de base principal	1 pc
2	Tube de base arrière	1 pc
3	Tube de base avant	1 pc
4	Support supérieur	1 pc
5	Support vertical	1 pc
6	Support du siège	1 pc
7	Extension de jambe	1 pc
8	Tube renforcé	1 pc
9	Support de rameur	1 pc
10	Presse-poitrine	1 pc
11	Bras gauche	1 pc
12	Bras droit	1 pc
13	"Support en forme de "H	1 pc
14	Barre de traction	1 pc
15	Barre de curling	1 pc
16	Barre à poignées	4 pcs
17	Plaque en acier	2 pcs
18	Tube en mousse (370mm)	2 pcs
19	Bras de rameur	2 pcs
20	Support rond	2 pcs
21	Sélecteur de poids	1 pc
22	Barres chromées (1820mm)	2 pcs
23	Filet en acier	4 pcs
24	Poids supérieurs	1 pc
25	Bloc de poids Douille	1 pc
26	Goupille $\Phi 10$	1 pc
27	Grande rondelle ( $\Phi 45$ )	1 pc

Pièces	Description	Qté
28	Coussin en caoutchouc	2 pcs
29	Poids	9 pcs
30	Arbre de poulie	1 pc
31	Goupille de verrouillage 10*150	1 pc
32	Siège de poulie	2 pcs
33	Support de poulie	1 pc
34	Câble 1	1 pc
35	Plaque de réglage	2 pcs
36	Poulie ( $\Phi 90$ )	14 pcs
37	Douille de poulie	6 pcs
38	Crochet de sécurité	5 pcs
39	Câble 2	1 pc
40	Chaîne	2 pcs
41	Grande rondelle ( $\Phi 50$ )	2 pcs
42	Douille en acier	6 pcs
43	Mousse (250mm)	2 pcs
44	Câble 3	1 pc
45	Mousse (160mm)	4 pcs
46	Coussin de siège	1 pc
47	Pare-chocs en PVC $\Phi 30*7$	4 pcs
48	Place renforcée (100mm)	3 pcs
49	Pare-chocs en caoutchouc	1 pc
50	Coussin de dossier	1 pc
51	Support d'hélice	1 pc
52	Passage de poulie ( $\Phi 16$ )	1 pc
54	Cache-pied	6 pcs

# LISTE DES PIÈCES 1

1. 1PC 	2. 1PC 	3. 1PC 	4. 1PC 	5. 1PC 
6. 1PC 	7. 1PC 	8. 1PC 	9. 1PC 	22. 2PCS 
10. 1PC 	11. 1PC 	12. 1PC 	13. 1PC 	23. 4PCS 
14. 1PC 	15. 1PC 	16. 4PCS 	17. 2PCS 	
18. 2PCS 	19. 2PCS 	20. 2PCS 	21. 1PC 	24. 1PC 
25. 1PC 	26. 1PC 	27. 1PC 	28. 2PCS 	29. 9PCS 
30. 1PC 	31. 1PC 	32. 2PCS 	33. 1PC 	34. 1PC 
35. 2PCS 	36. 14PCS 	37. 6PCS 	38. 5PCS 	39. 1PC 
40. 2PCS 	41. 2PCS 	42. 6PCS 	43. 2PCS (MOUSSE) 	44. 1PC 
45. 4PCS (MOUSSE) 	46. 1PC 	47. 3PCS 	48. 3PCS 	49. 1PC 
50. 1PC 	51. 1PC 	52. 2PC 	54. 6PCS 	

## LISTE DE PIÈCES 2

<p>55. 1PC (M12*190)</p> 	<p>69. 1PC (M10*110)</p> 
<p>56. 2PCS (M12*85)</p> 	
<p>57. 3PCS (M10*90)</p> 	
<p>58. 1PC (M10*75)</p> 	
<p>59. 2PCS (M10*60)</p> 	
<p>60. 8PCS (M10*50)</p> 	
<p>61. 13PCS (M10*45)</p> 	
<p>62. 2PCS (M10*40)</p> 	
<p>63. 2PCS (M10*25)</p> 	
<p>64. 11PCS (M10*25)</p> 	
<p>65. 4PCS (M8*45)</p> 	
<p>66. 1PC (M10)</p> 	
<p>67. 4PCS (M8*20)</p> 	
<p>68. 2PCS (M6*16)</p> 	

## INSTALLATION

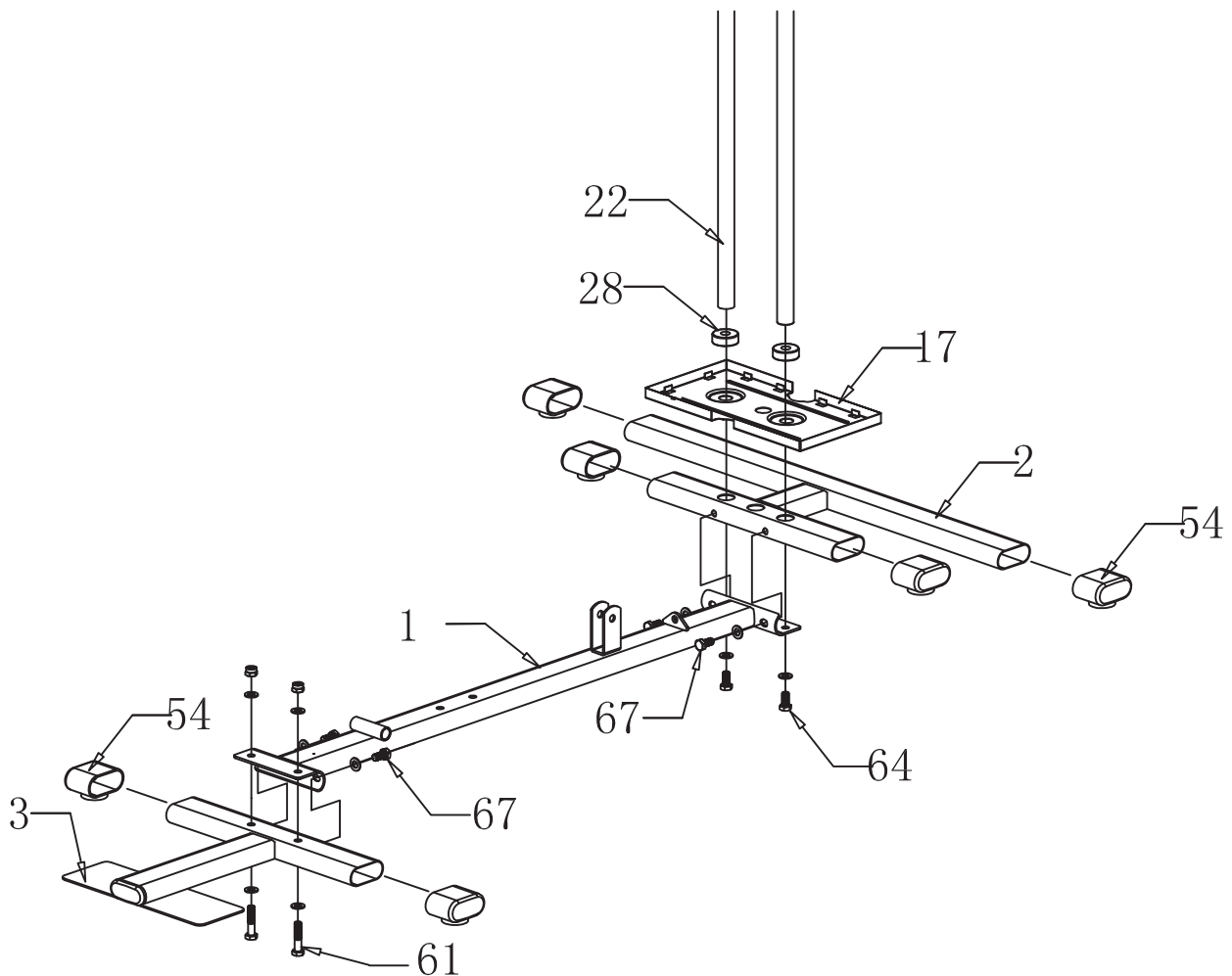

### Étape 1

1. Fixez le tube de base principal (1) au tube de base arrière (2), la barre chromée (22) à l'aide de boulons hexagonaux M10x25 (64-2 jeux), de rondelles et de boulons hexagonaux M8x20 (67-2 jeux), de rondelles.

2. Fixez le tube de base principal (1) au tube de base avant (3) à l'aide de boulons hexagonaux M10x45 (61-2 jeux), de rondelles, d'écrous et de boulons hexagonaux M8x20 (67-2 jeux) et de rondelles.



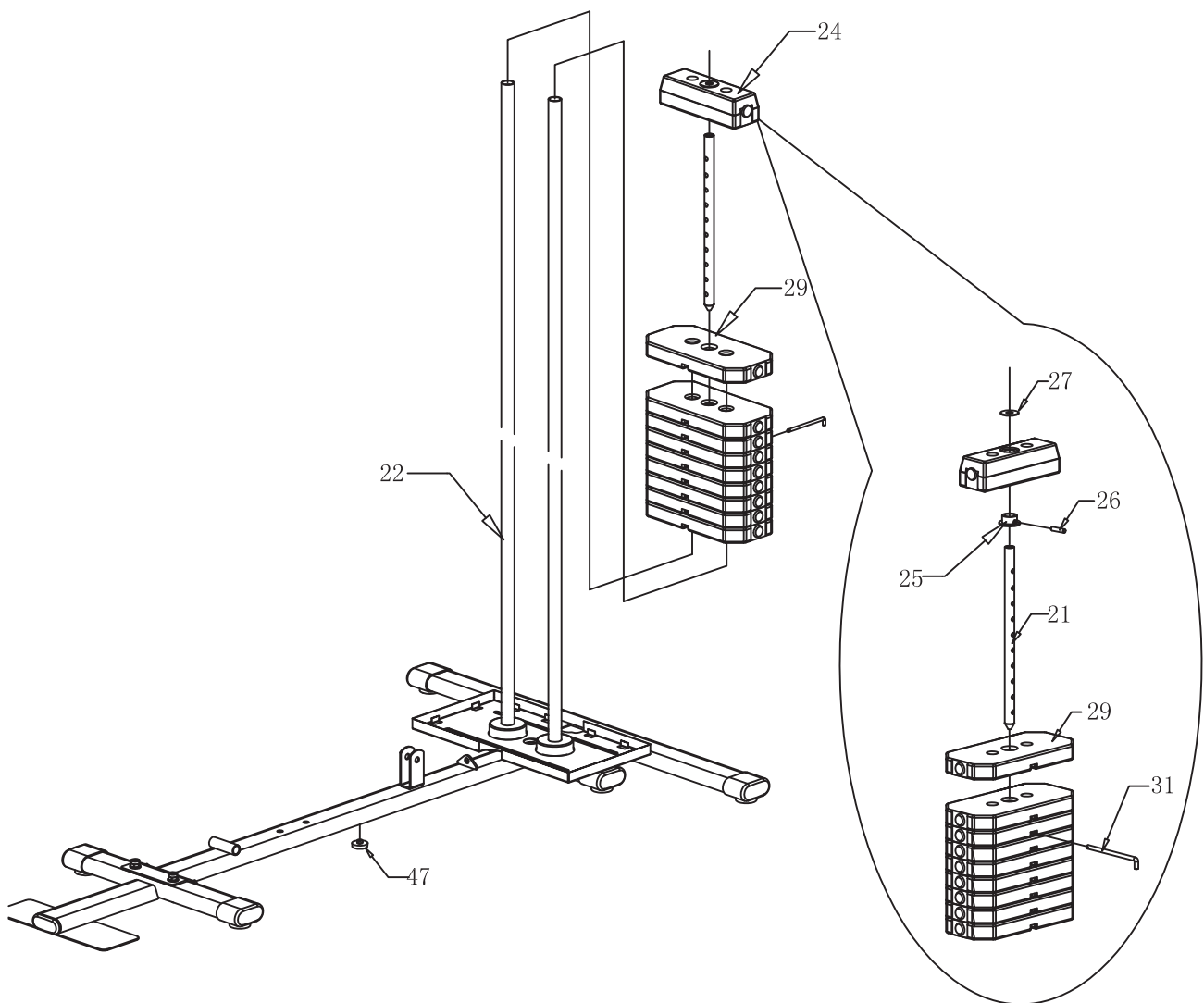

## Étape 2

1. Fixez les poids (24, 29) aux barres chromées (22) comme indiqué.

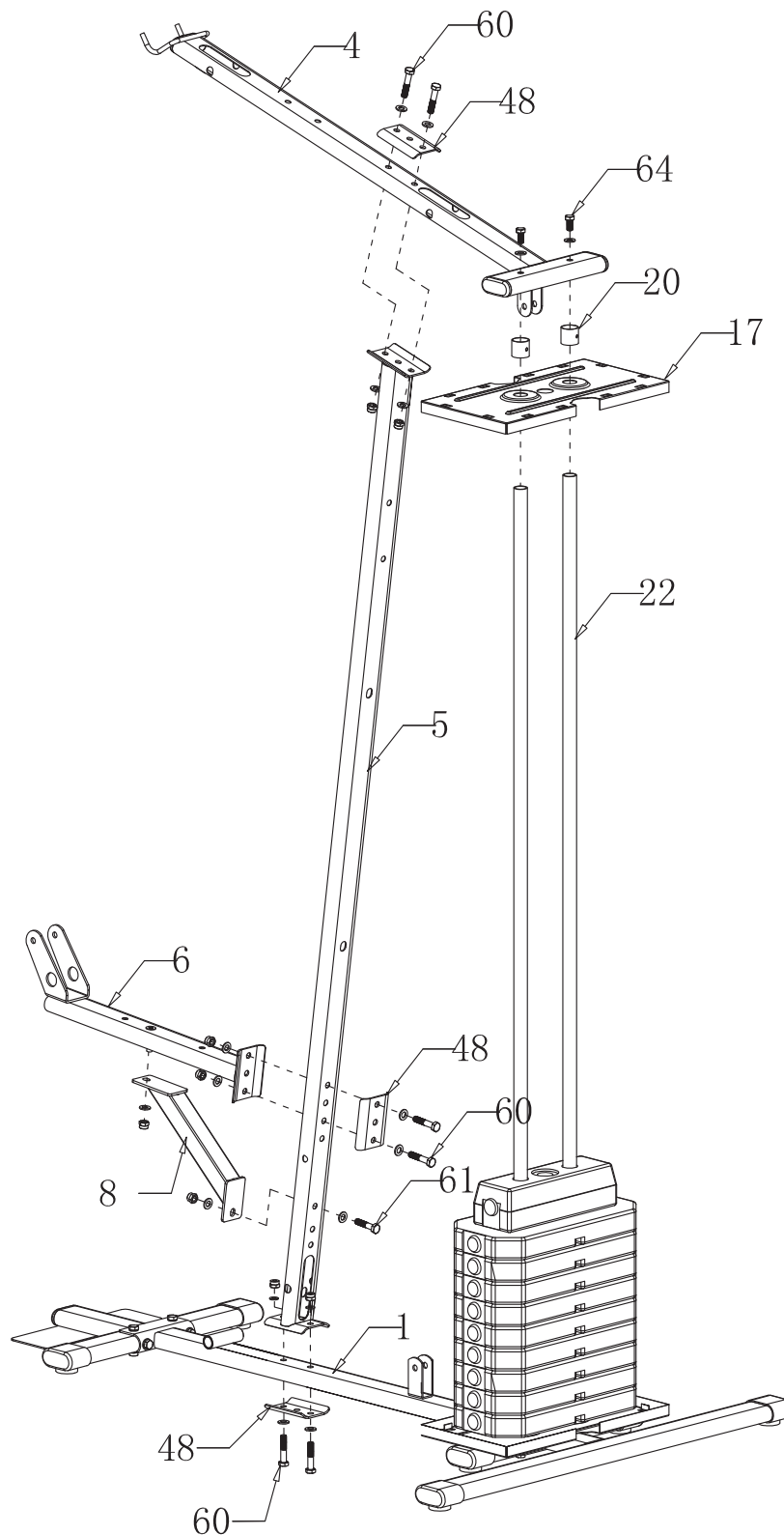

### Étape 3

1. Fixez le support vertical (5) au tube de base principal (1) à l'aide de la plaque renforcée (48) et des boulons hexagonaux M10x50 (60-2 jeux), rondelles et écrous.
2. Fixez le support supérieur (4) au support vertical (5) à l'aide de la plaque renforcée (48) et des boulons hexagonaux M10x50 (60-2 jeux) et insérez les barres chromées (22) dans les trous du support supérieur (4) à l'aide des boulons hexagonaux M10x25 (64-2 jeux).
3. Fixez le support du siège (6), le tube renforcé (8) au support vertical (5) en utilisant la plaque renforcée (48) et les boulons hexagonaux M10x50 (60-2 jeux), les boulons M10x45 (61-1 jeu), les rondelles et les écrous.

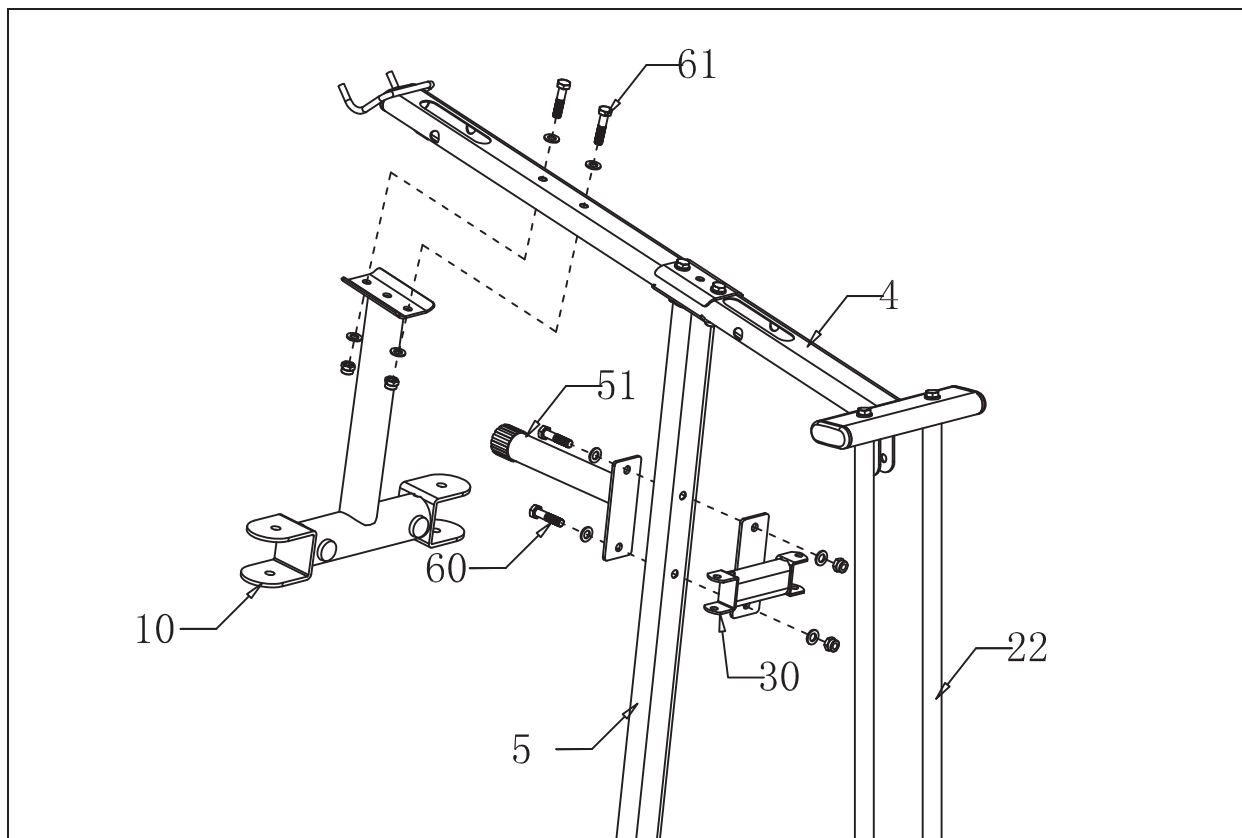

#### Étape 4

1. Fixez la presse de poitrine (10) au support supérieur (94) à l'aide de boulons hexagonaux M10 x 45 (61 - 2 jeux), de rondelles et d'écrous.

2. Fixez l'arbre de la poulie (30), le support pro (51) au support vertical (5) à l'aide de boulons hexagonaux M10 x 50 (51-2 jeux), de rondelles et d'écrous

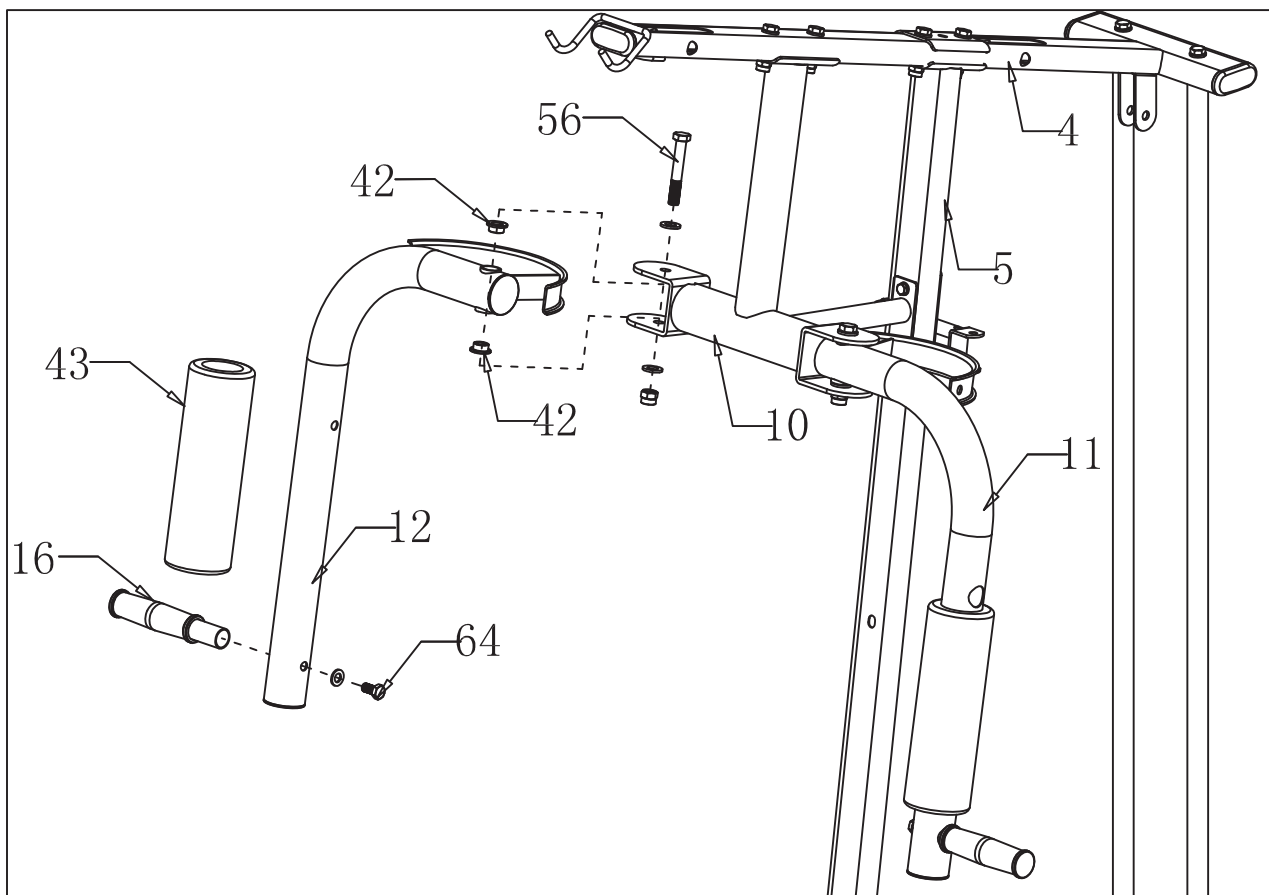

### Étape 5

1. Fixez le bras droit (12) à la presse de poitrine (10) à l'aide de la douille en acier (42) et des boulons hexagonaux M12x85 (56), des rondelles et des écrous.

2. Insérez le guidon (16) dans le bras droit (12) à l'aide de boulons hexagonaux M10x25 (64) et de rondelles.

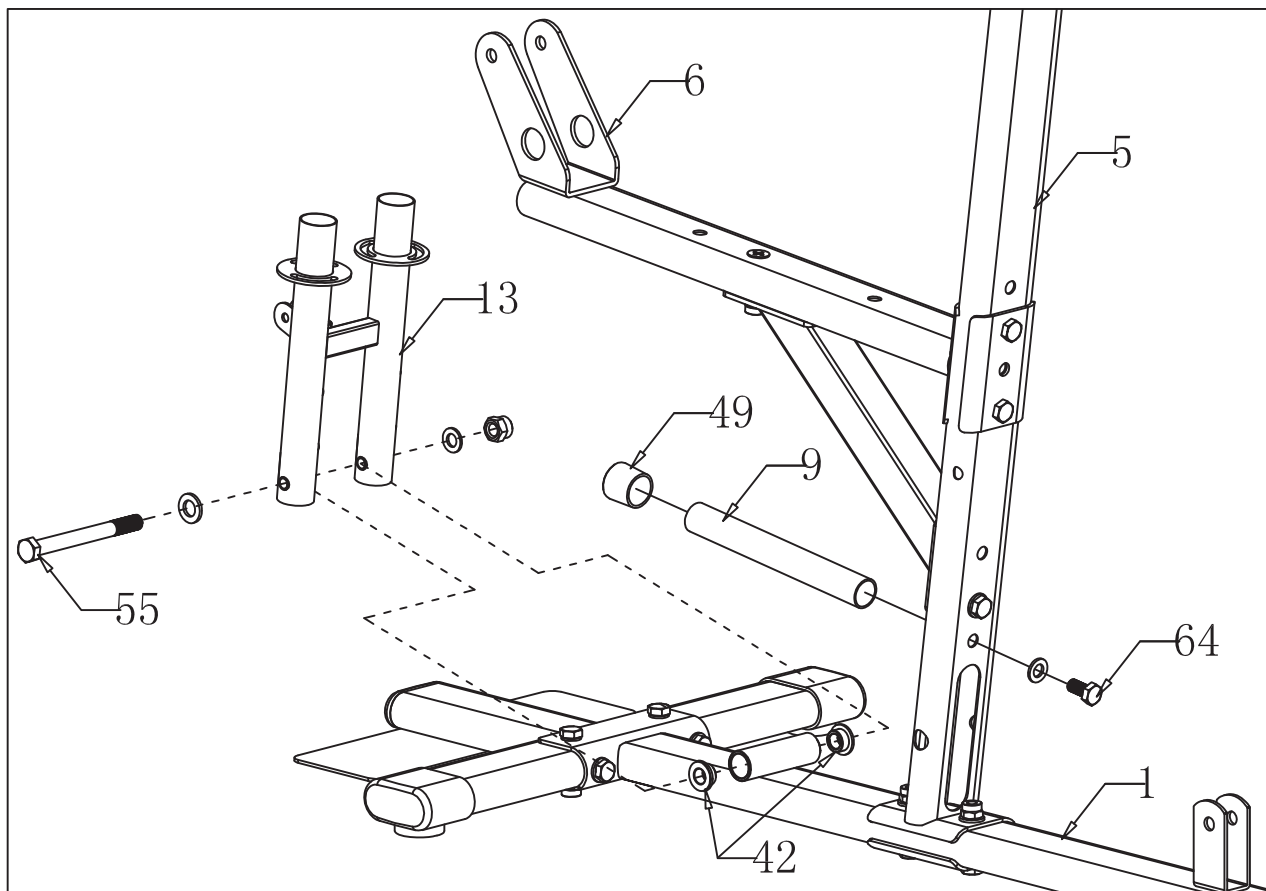

### Étape 6

1. Fixez le support en H (13) au tube de base principal (1) à l'aide de la douille en acier (42) et des boulons hexagonaux M12 x 190, de la rondelle (55) et de l'écrou.

2. Insérez le support d'aviron (9) dans les trous du support vertical (5) à l'aide des boulons hexagonaux M10 x 25 et de la rondelle (64).

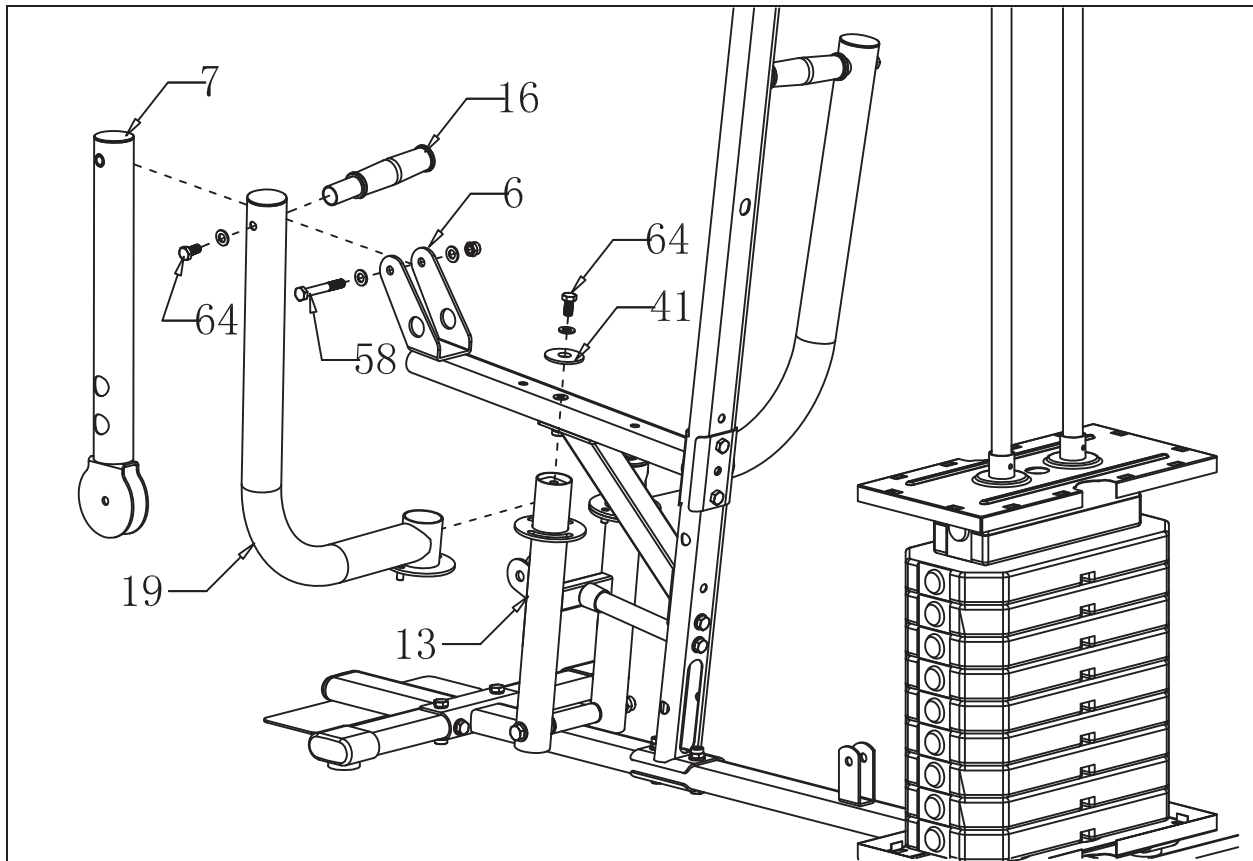

Étape 7:

1. Fixer l'extension de la jambe (7) au support du siège (6) à l'aide de boulons hexagonaux M10x75 (58-1 jeu) et de rondelles et d'écrous.

2. Insérer le bras de rameur (19) dans le support en forme de H (7) en utilisant la grande rondelle (41) et les boulons hexagonaux M10x25 (64-2 jeux).

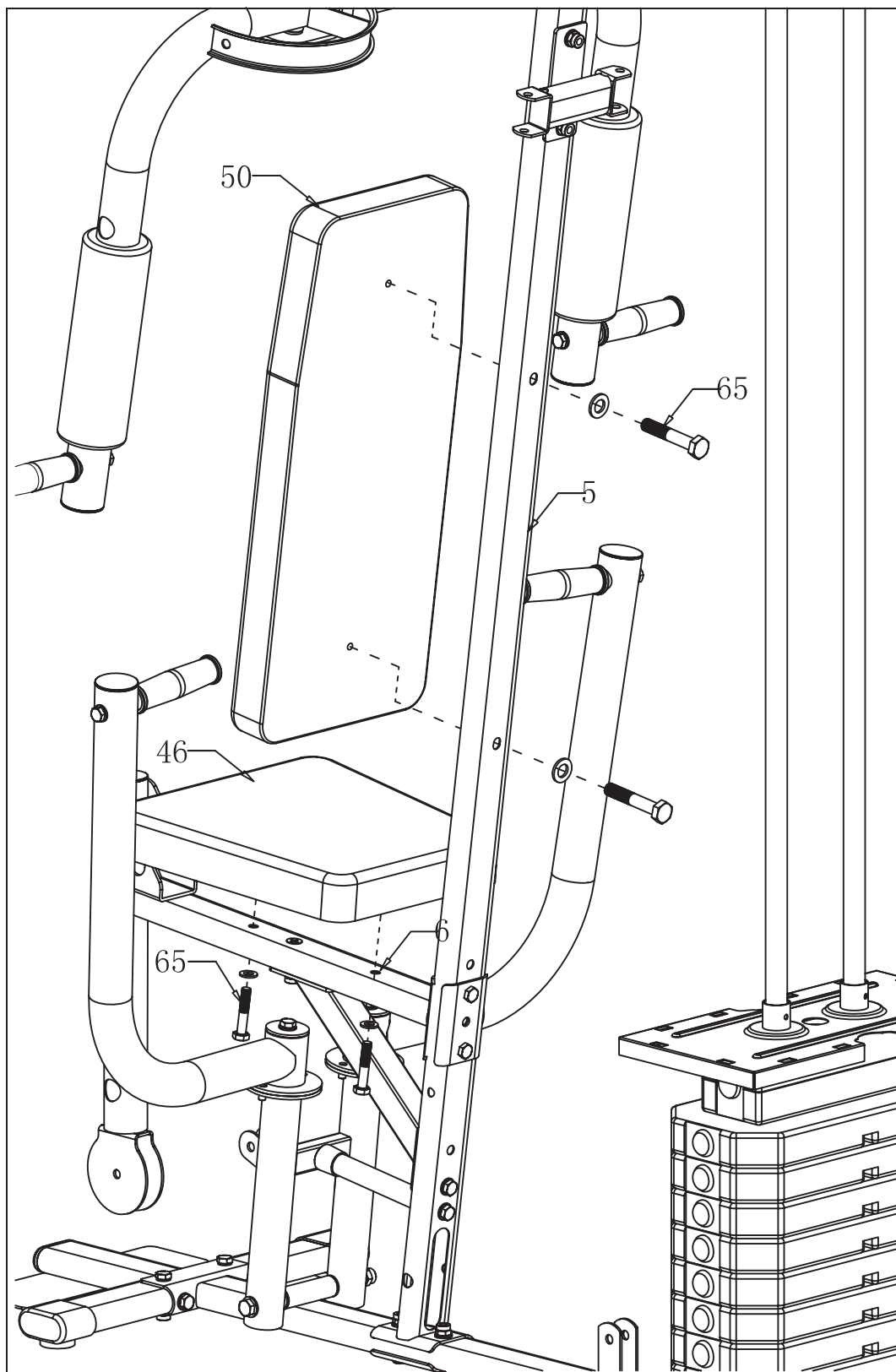

Étape 8:

1. Fixez le coussin dorsal (50) au support vertical (5) à l'aide des boulons hexagonaux M8x45 (65-2 jeux) et des rondelles.

2. Fixez le coussin de siège (46) au support de siège (6) à l'aide de boulons hexagonaux M8x45 (65-2 jeux) et des rondelles.

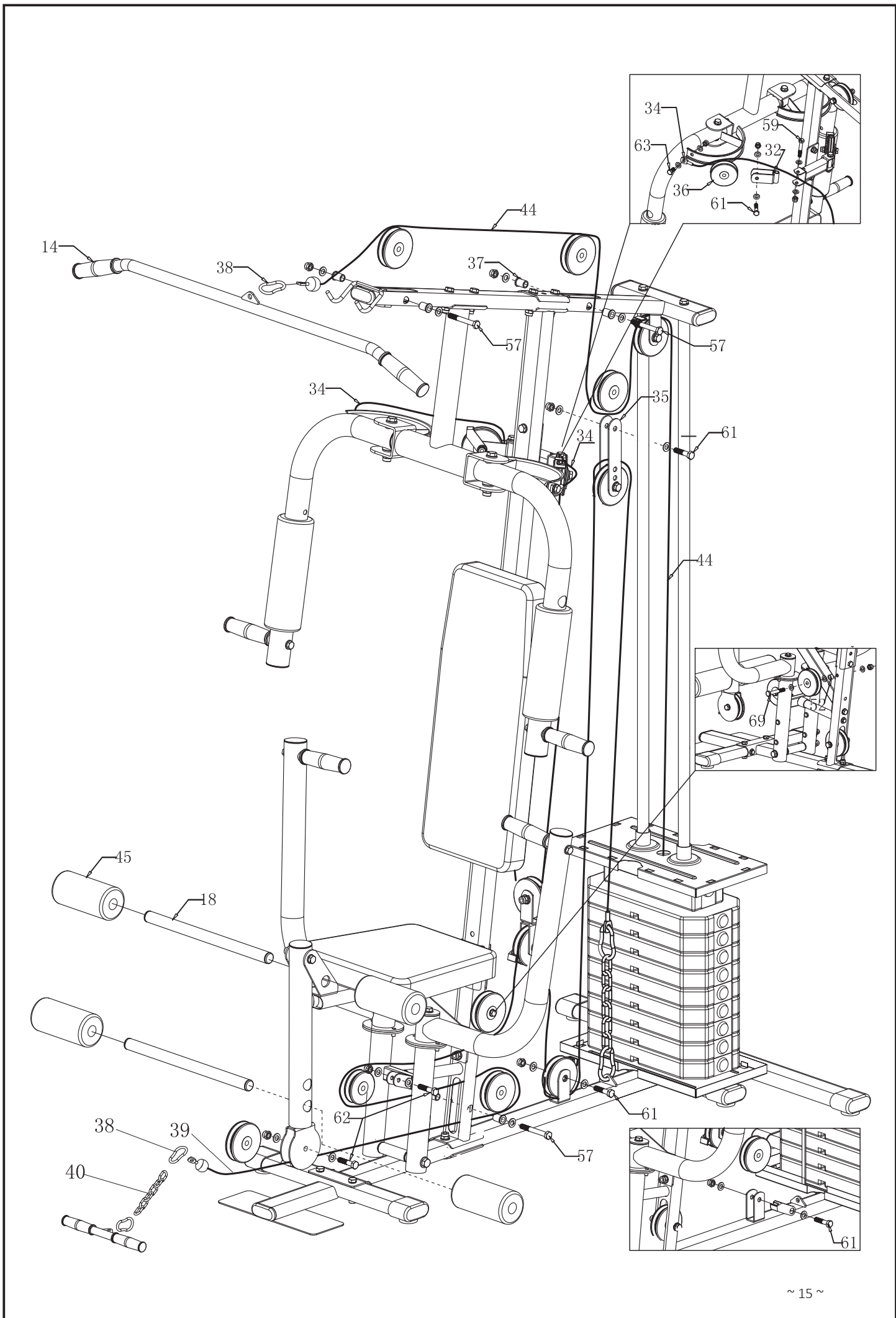



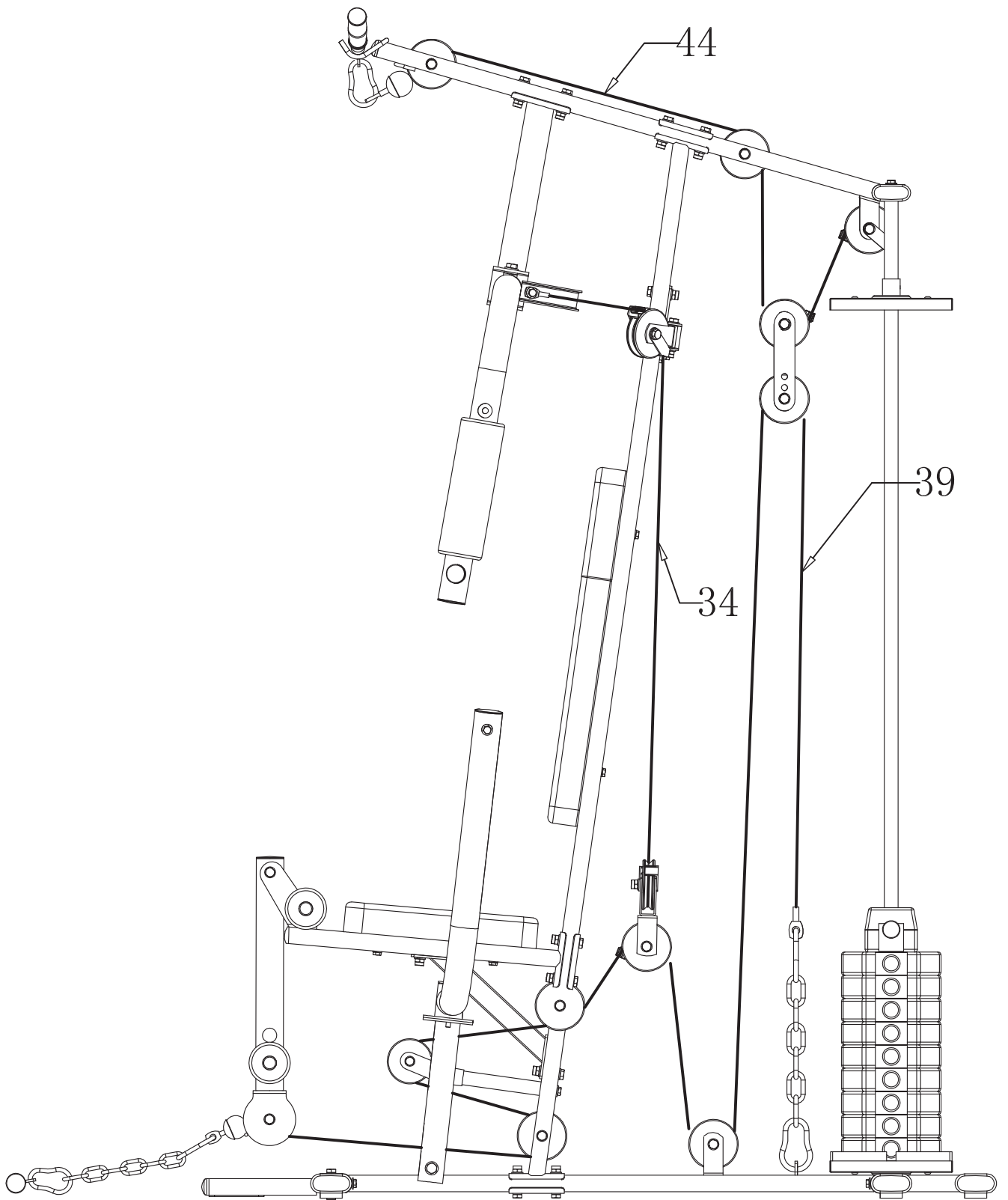

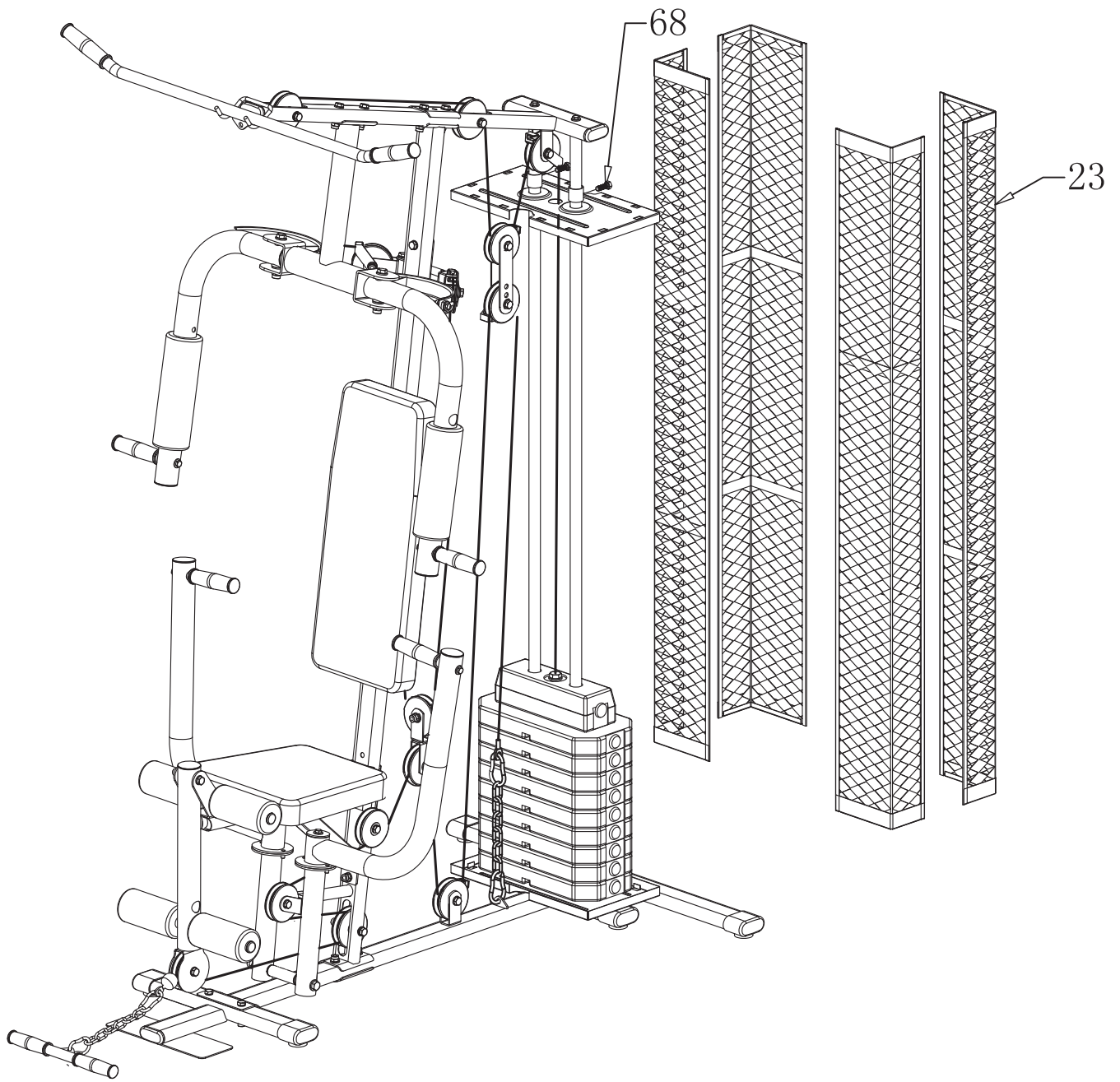

## CLEANING AND MAINTENANCE

1. Regularly examine the equipment to detect any damage to wear which may have occurred. The safety level of the equipment can be maintained only if it is examined regularly for damage and wear and tear on ropes, pulleys, and connection points.
2. Lubricate moving parts with light oil periodically to prevent premature wear.
3. Inspect and tighten all parts before using the equipment. Replace defective components immediately and/or keep the equipment out of use until repair. Pay particular attention to components most susceptible to wear.
4. The equipment can be cleaned using a soft, damp cloth. **Do not** use solvents or abrasive cleaners.

## DISPOSAL



According to the European waste regulation 2012/19/EU this symbol on the product or on its packaging indicates that this product may not be treated as household waste. Instead, it should be taken to the appropriate collection point for the recycling of electrical and electronic equipment. By ensuring this product is disposed of correctly, you will help prevent potential negative consequences for the environment and human health, which could otherwise be caused by inappropriate waste handling of this product. For more detailed information about recycling of this product, please contact your local council or your household waste disposal service.