

**EN\_** IMPORTANT, RETAIN FOR FUTURE REFERENCE: READ CAREFULLY.

**FR\_** IMPORTANT: A LIRE ATTENTIVEMENT ET À CONSERVER POUR CONSULTATION ULTÉRIEURE.

**ES\_** IMPORTANTE, LEA Y GUARDE PARA FUTURAS REFERENCIAS.

**DE\_**, WICHTIG! SORGFÄLTIG LESEN UND FÜR SPÄTER NACHSCHLAGEN AUFBEWAHREN."

**IT\_** IMPORTANTE! CONSERVARE IL PRESENTE MANUALE PER FUTURO RIFERIMENTO E LEGGERLO ATTENTAMENTE.

**EN:** Please note: The whole assembly process needs to be done on flat ground otherwise uneven table top might be caused. If the table top is uneven, please see step 5 and step 6.

The first part is to loosen the screw M, the second part is to adjust the height of part B, which can be tightened or relaxed, and then tighten the screw M again.

**FR:** Veuillez noter que l'ensemble du processus de montage doit être effectué sur un terrain plat, faute de quoi le sommet du tableau risque d'être inégal. Si le haut du tableau est inégal, voir les étapes 5 et 6.

La première partie consiste à desserrer la vis, la seconde à ajuster la hauteur de la partie B, qui peut être serrée ou détendue, puis à serrer à nouveau la vis.

**ES:** Nota: Todo el proceso del montaje debe ser realizado sobre un terreno plano, de lo contrario, la superficie de la mesa podría quedar desnivelada. Si la superficie de la mesa está desnivelada, consulte los pasos 5 y 6.

En primer lugar, afloje el tornillo M, en el segundo lugar, ajuste la altura de la parte B, que se puede apretar o aflojar, y luego apriete nuevamente el tornillo M.

**DE:** Hinweis: Der gesamte Montageprozess muss auf ebenem Boden erfolgen, da sonst eine unebene Tischplatte entstehen kann. Wenn die Tischplatte uneben ist, lesen Sie bitte Schritt 5 und Schritt 6.

Als erstes wird die Schraube M gelockert, als zweites wird die Höhe von Teil B eingestellt, die angezogen oder gelockert werden kann, und dann wird die Schraube M wieder angezogen.

**IT:** Nota: l'intero processo di assemblaggio deve essere eseguito su un pavimento piano, altrimenti un piano del tavolo irregolare potrebbe verificarsi. Se il piano del tavolo non è livellato, fai riferimento ai passaggi 5 e 6.

Il primo passo è di allentare la vite M, il secondo è di regolare l'altezza della parte B che può essere serrata o allentata, e poi serrare nuovamente la vite M.

Carton 1/2

① ② ③ ④

Carton 2/2

⑤ ⑥x2 Hardware

EXPLOSION FIGURE

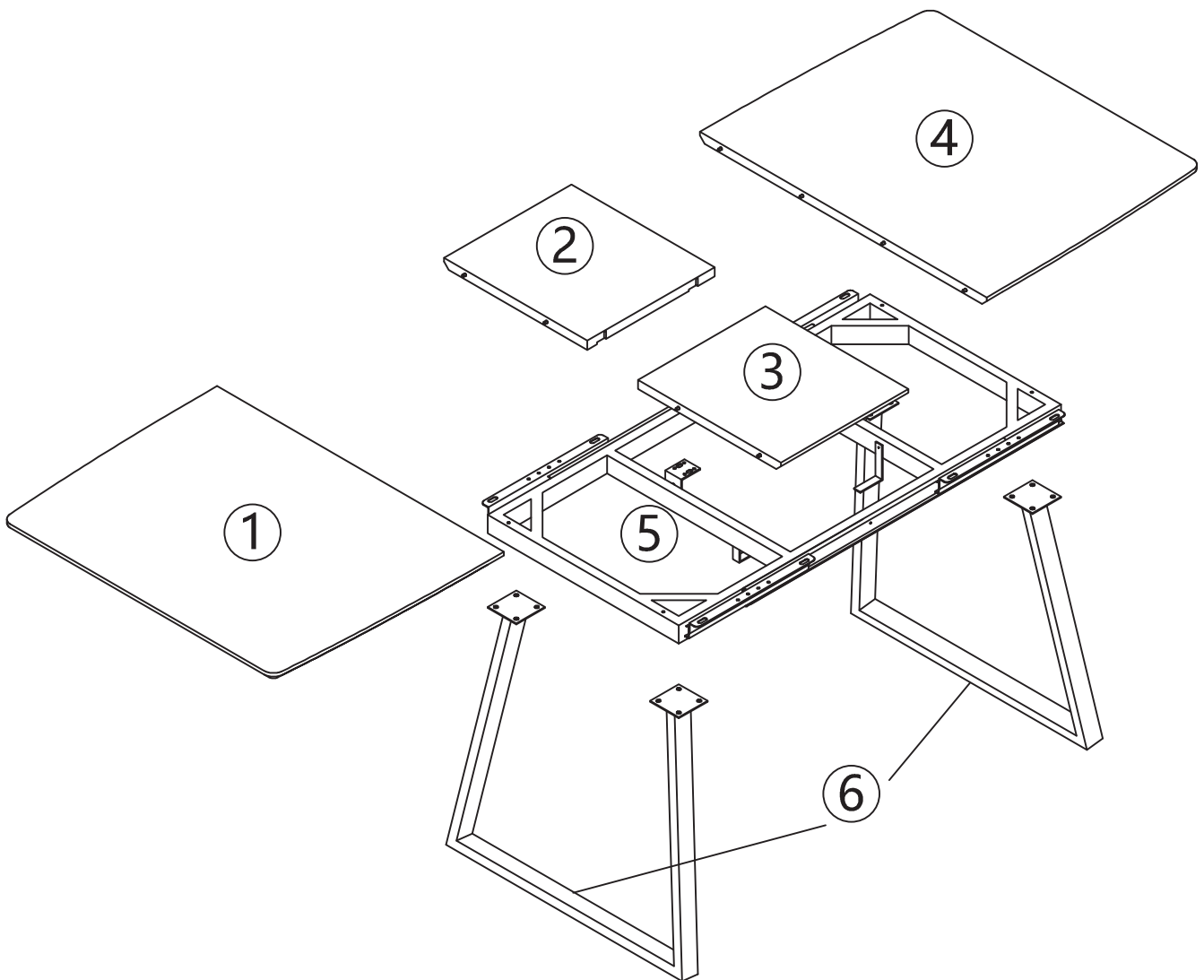

**A x 8**  
+1 (spare)

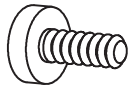

M6\*16

**B x 8**  
+1 (spare)



M6x8

**C x 16**  
+1 (spare)

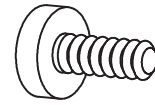

M8\*20

**D x 16**  
+1 (spare)



M3.5\*14

**E x 16**



4\*14

**F x 12**

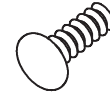

M6

**G x 16**  
+1 (spare)



∅8\*18

**H x 12**  
+1 (spare)



∅6\*16

**I x 2**



**J x 4**



**K x 4**



**L x 4**



M8

**M x 4**  
+1 (spare)

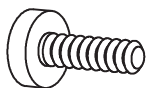

M6\*18

**N x 1**



5#

**O x 1**



3#

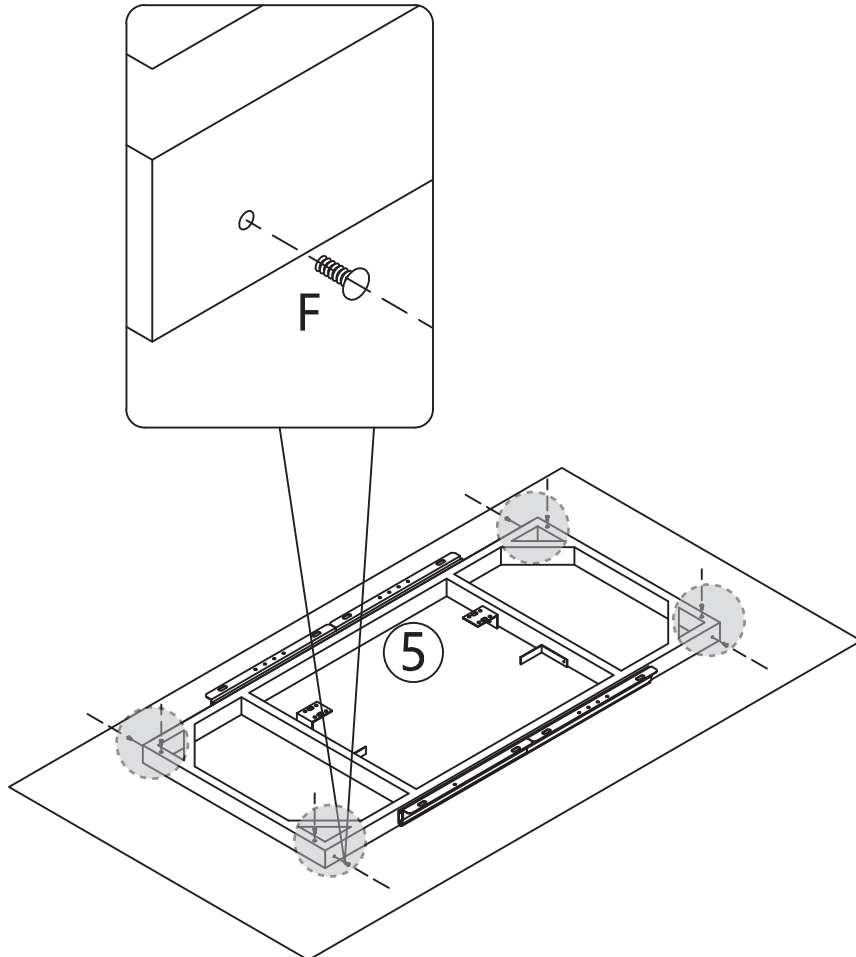
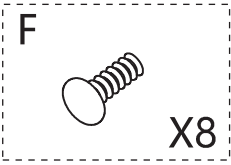
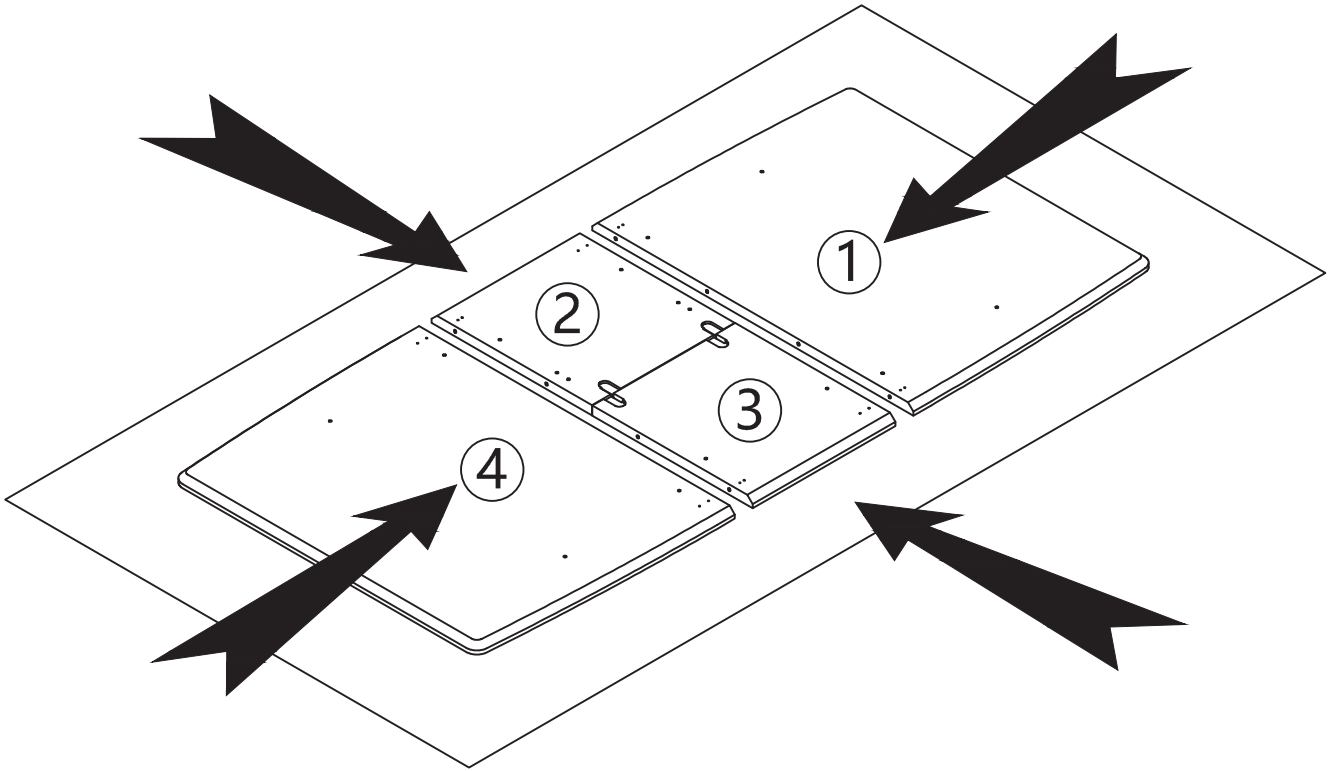

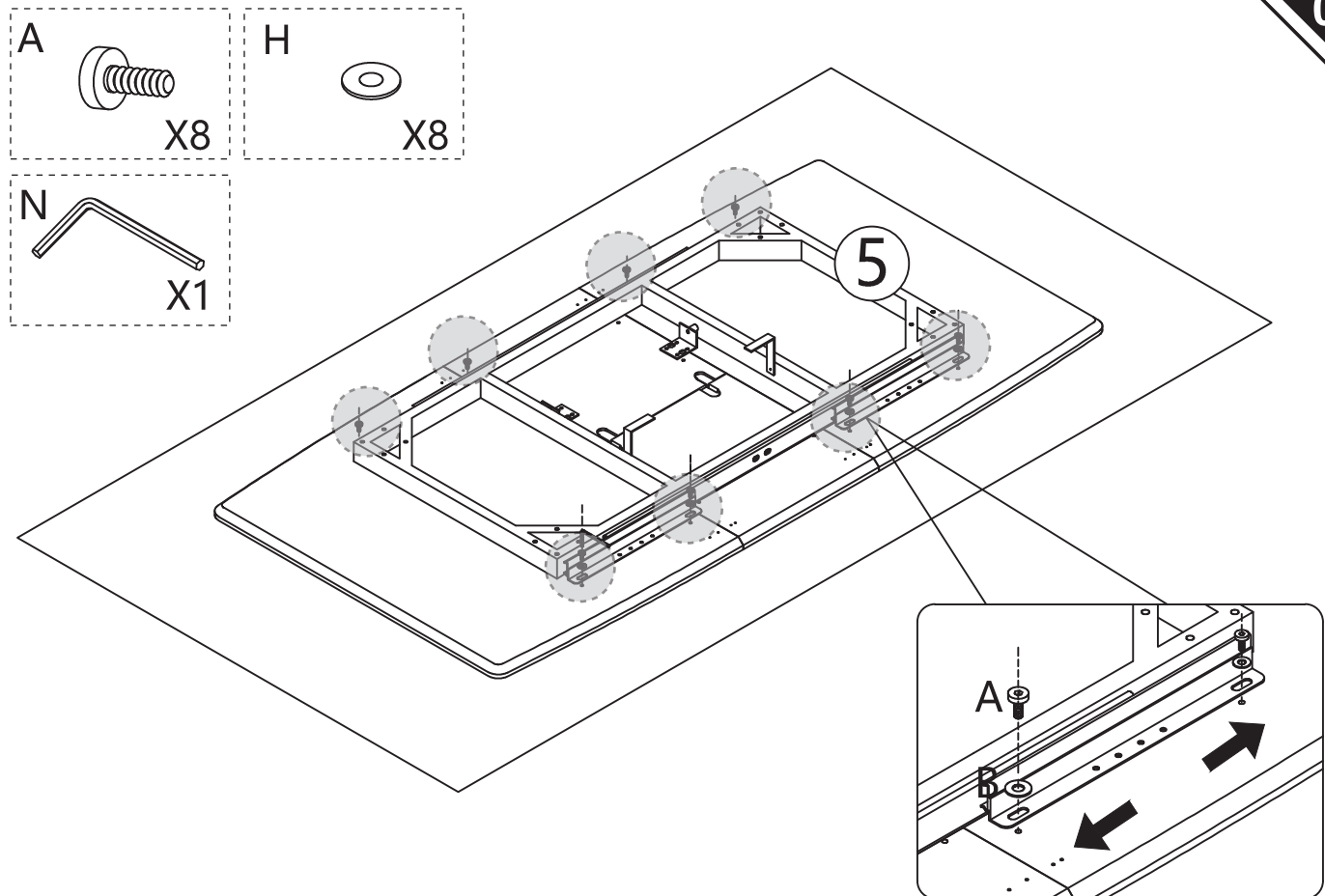
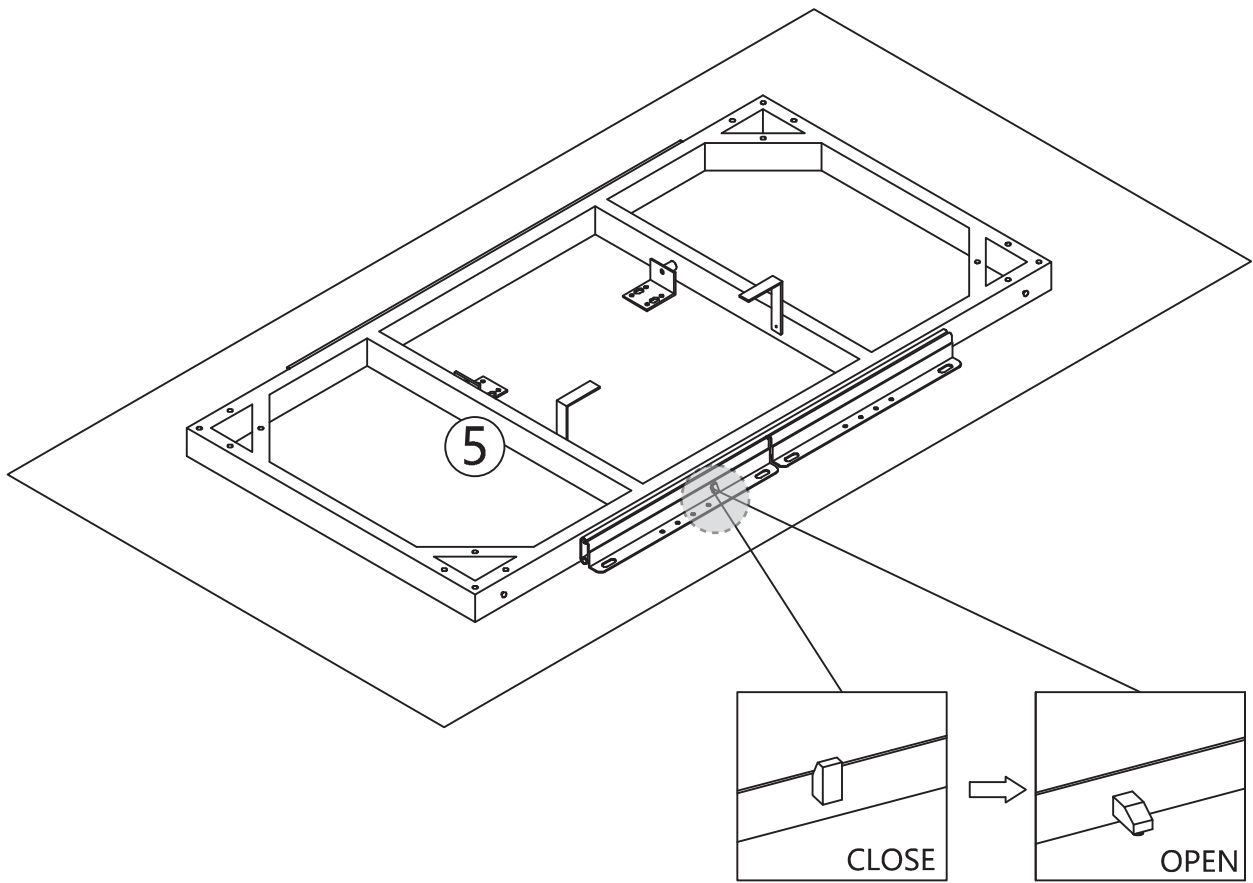



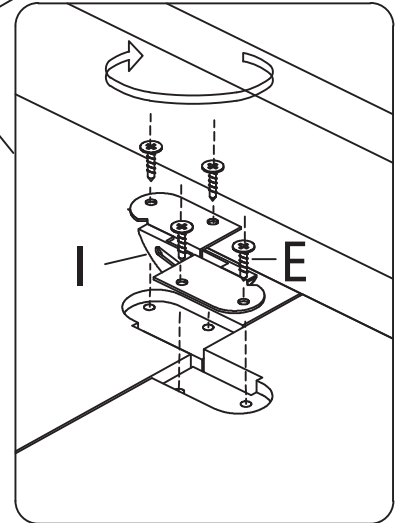
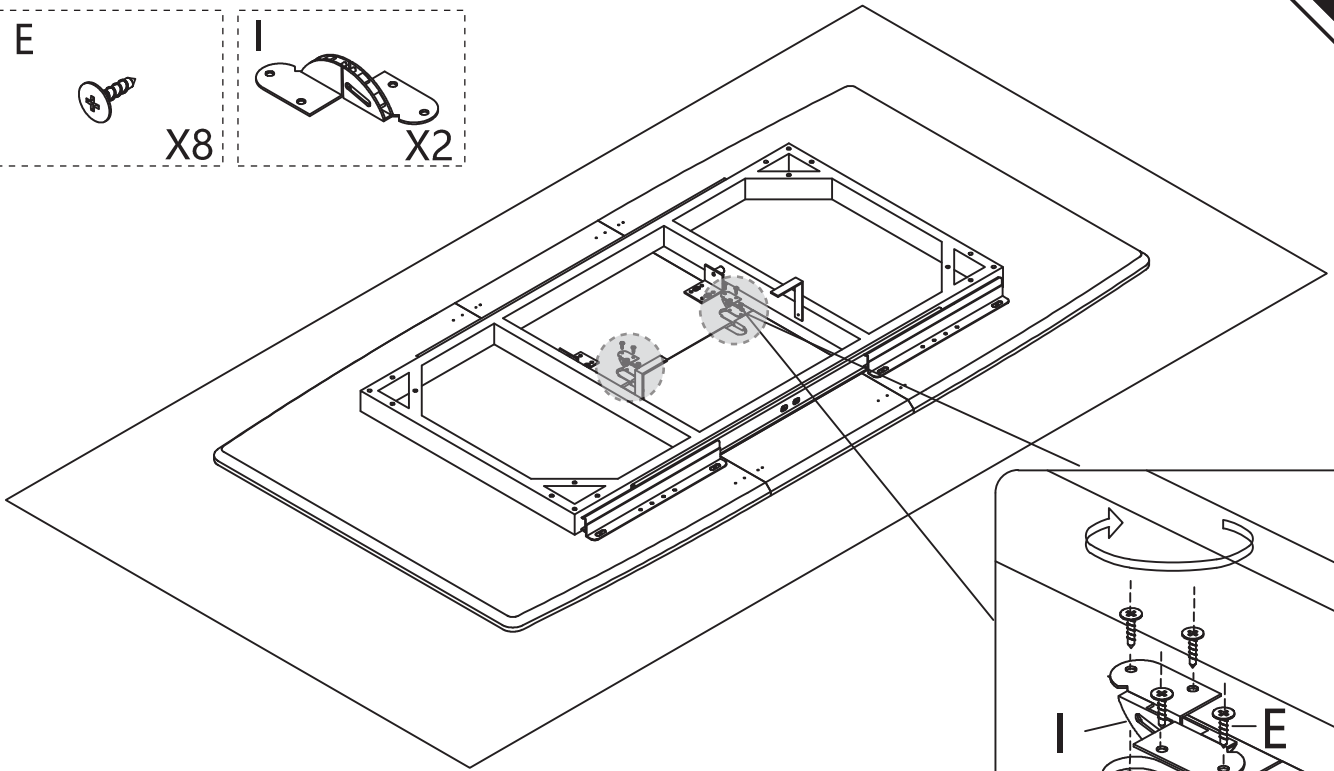
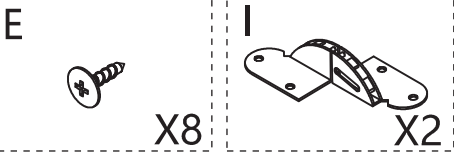

05

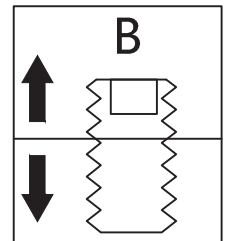
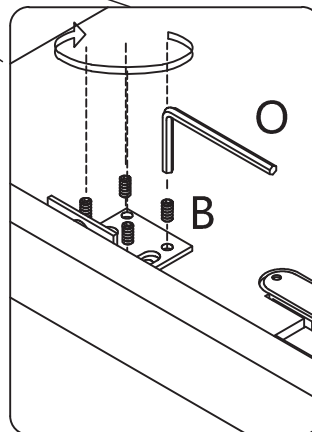
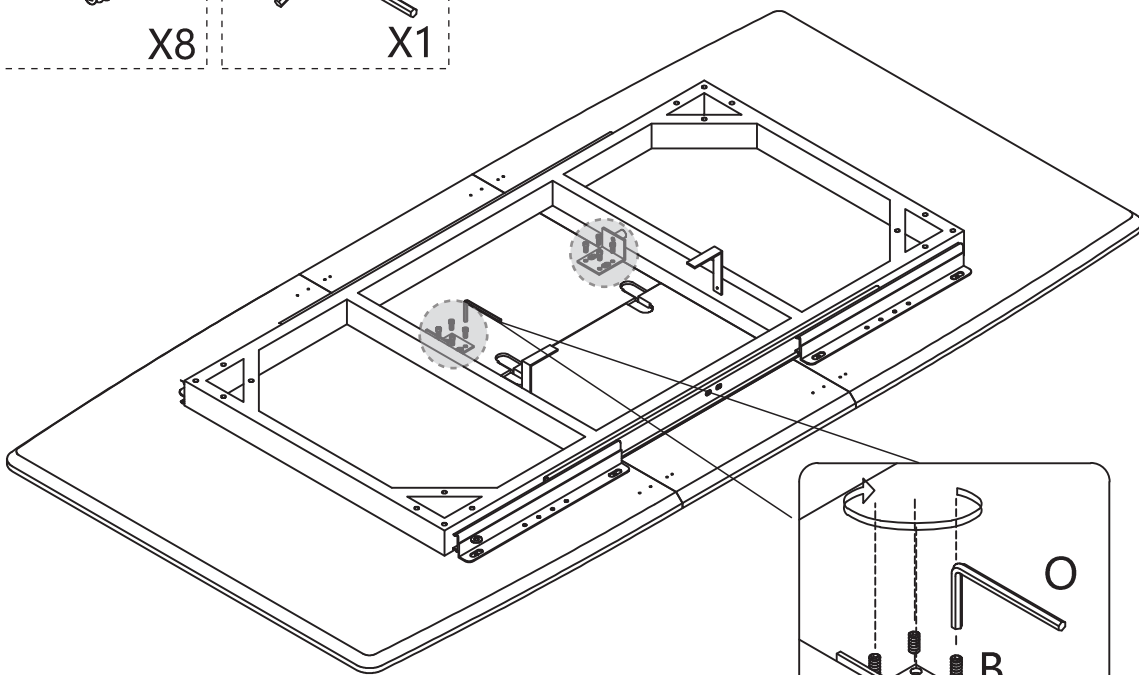
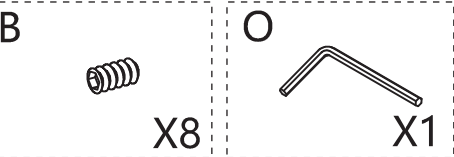

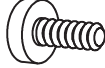

06

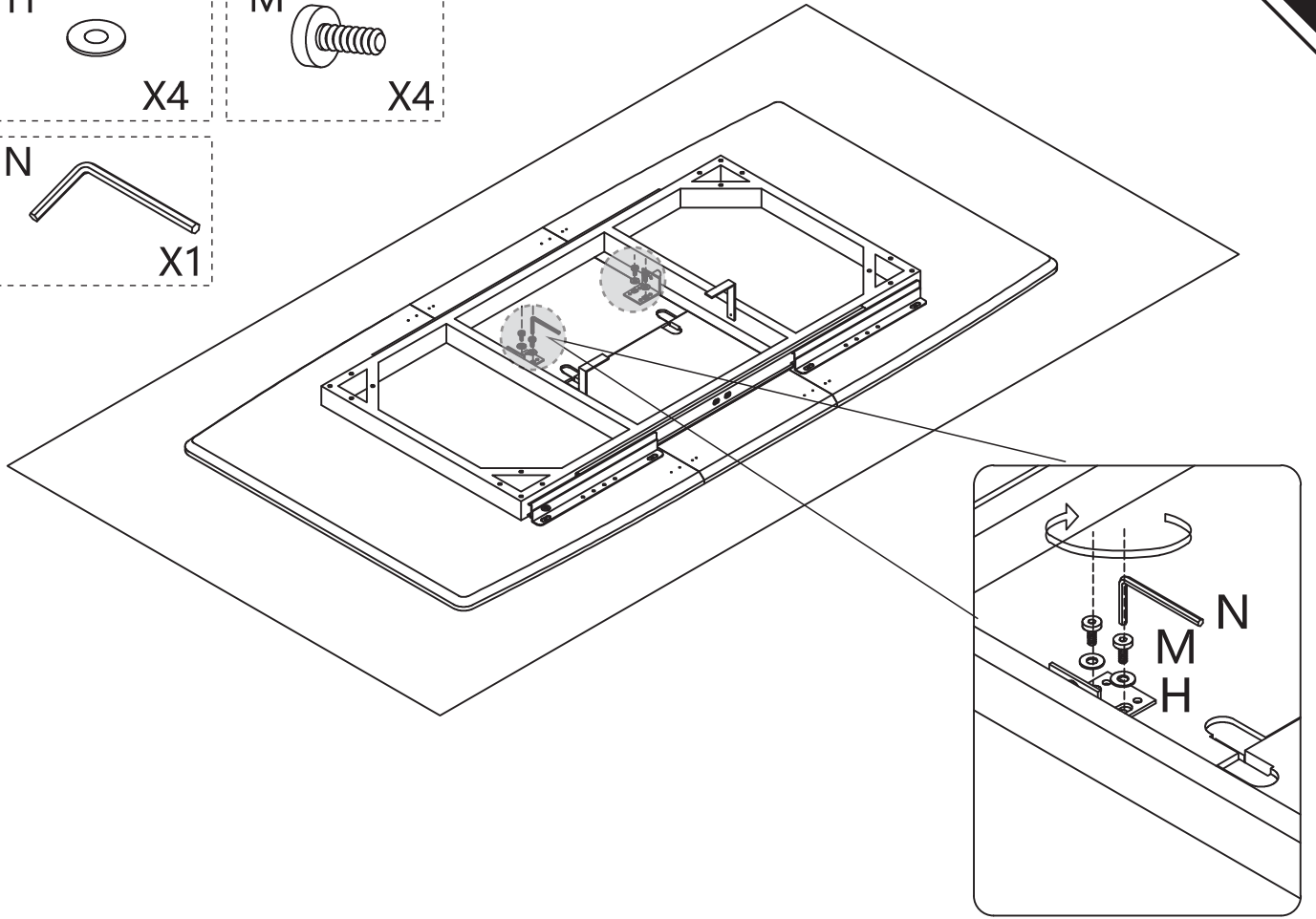

- H  X4
- M  X4
- N  X1



- D  X16
- J  X4
- K  X4

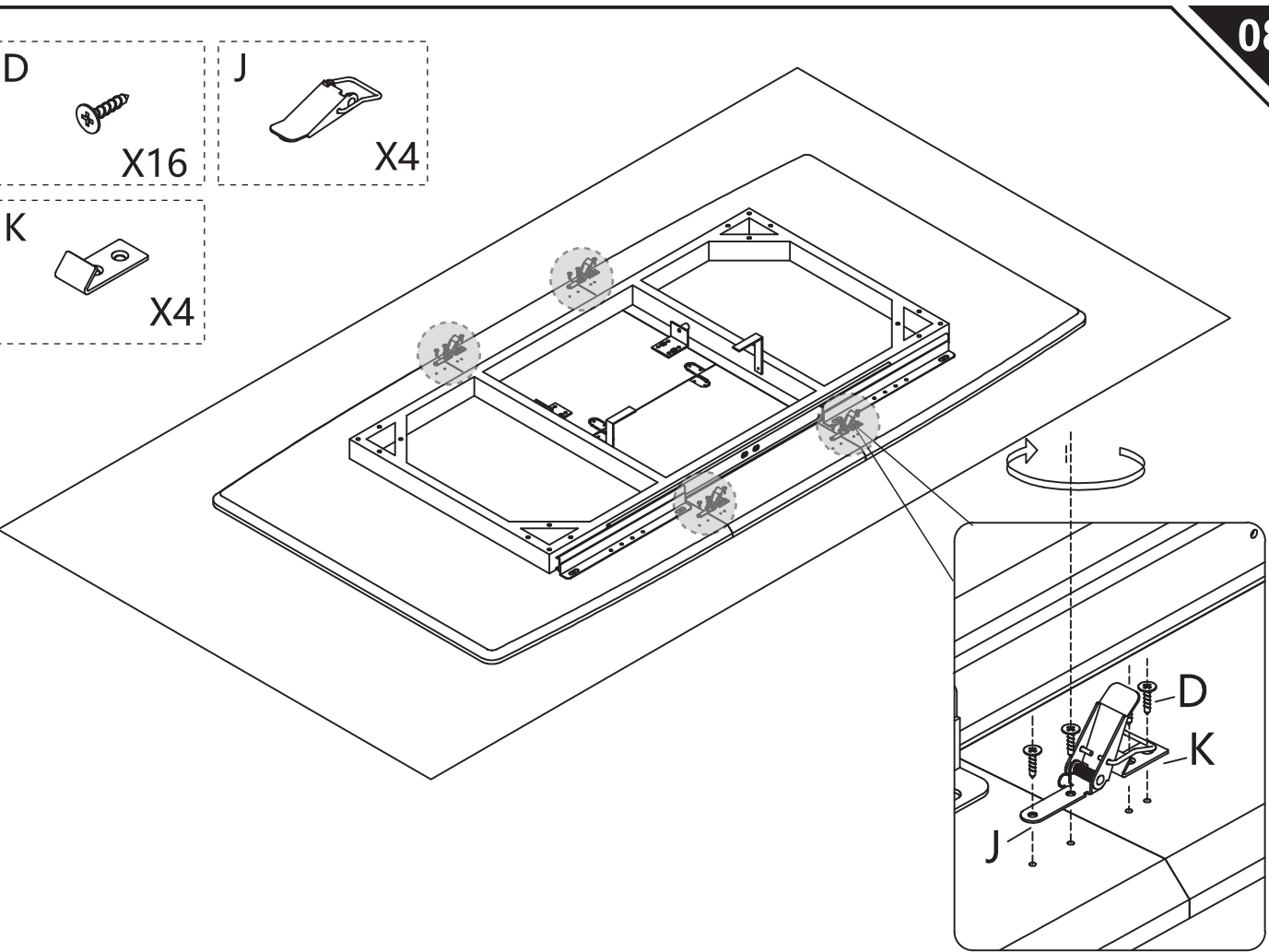



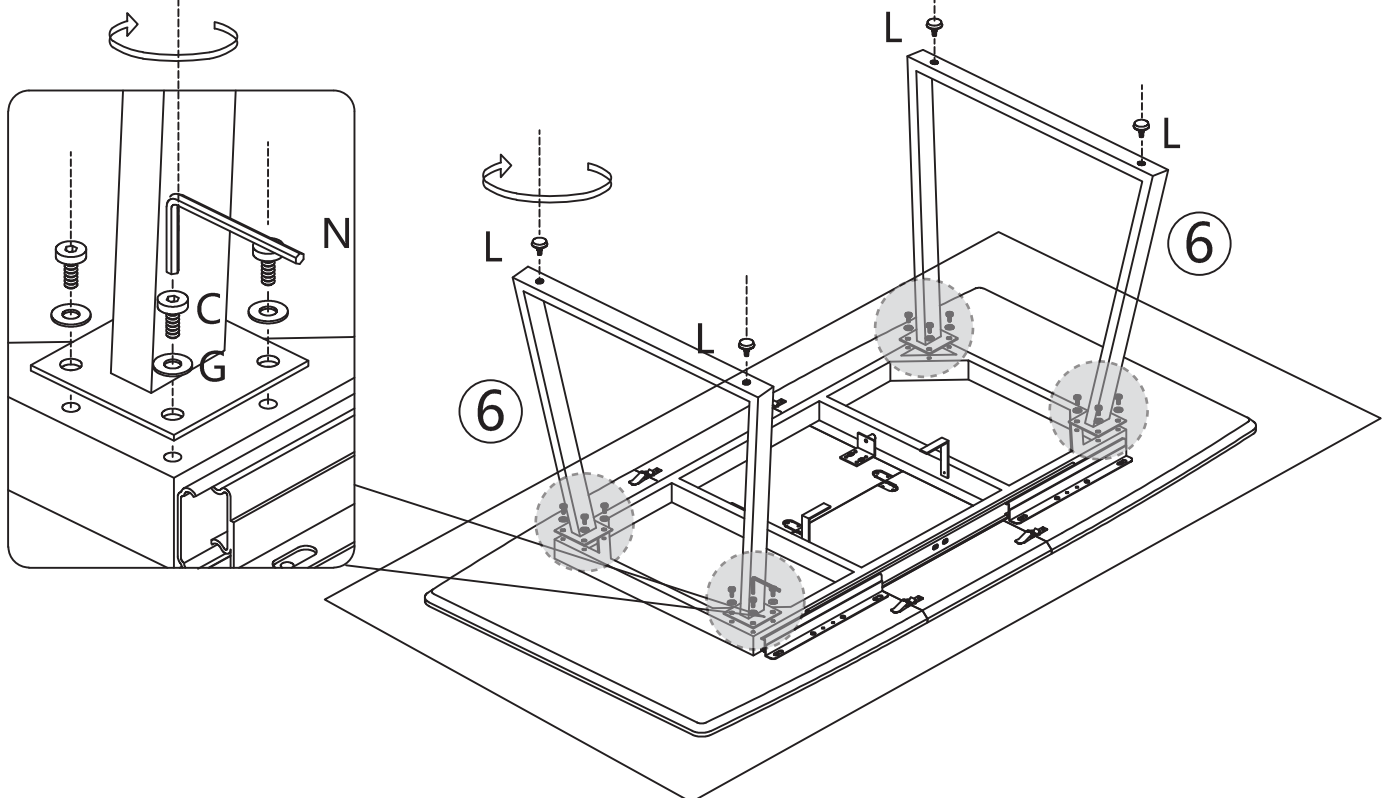
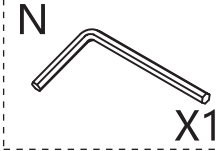
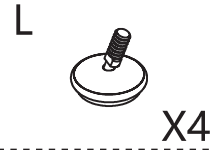
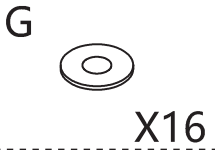
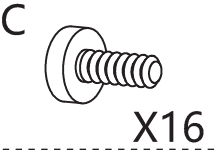
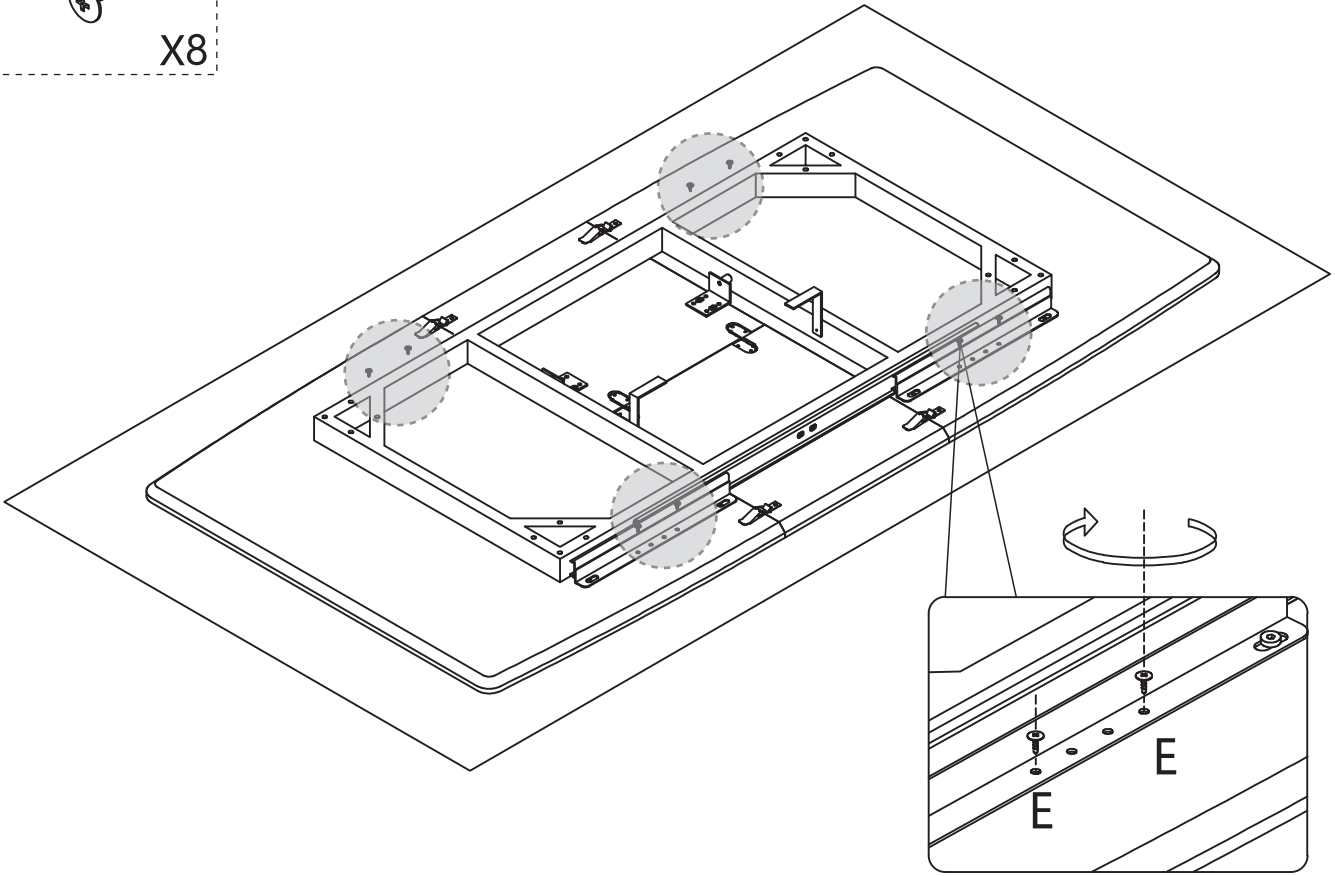

11

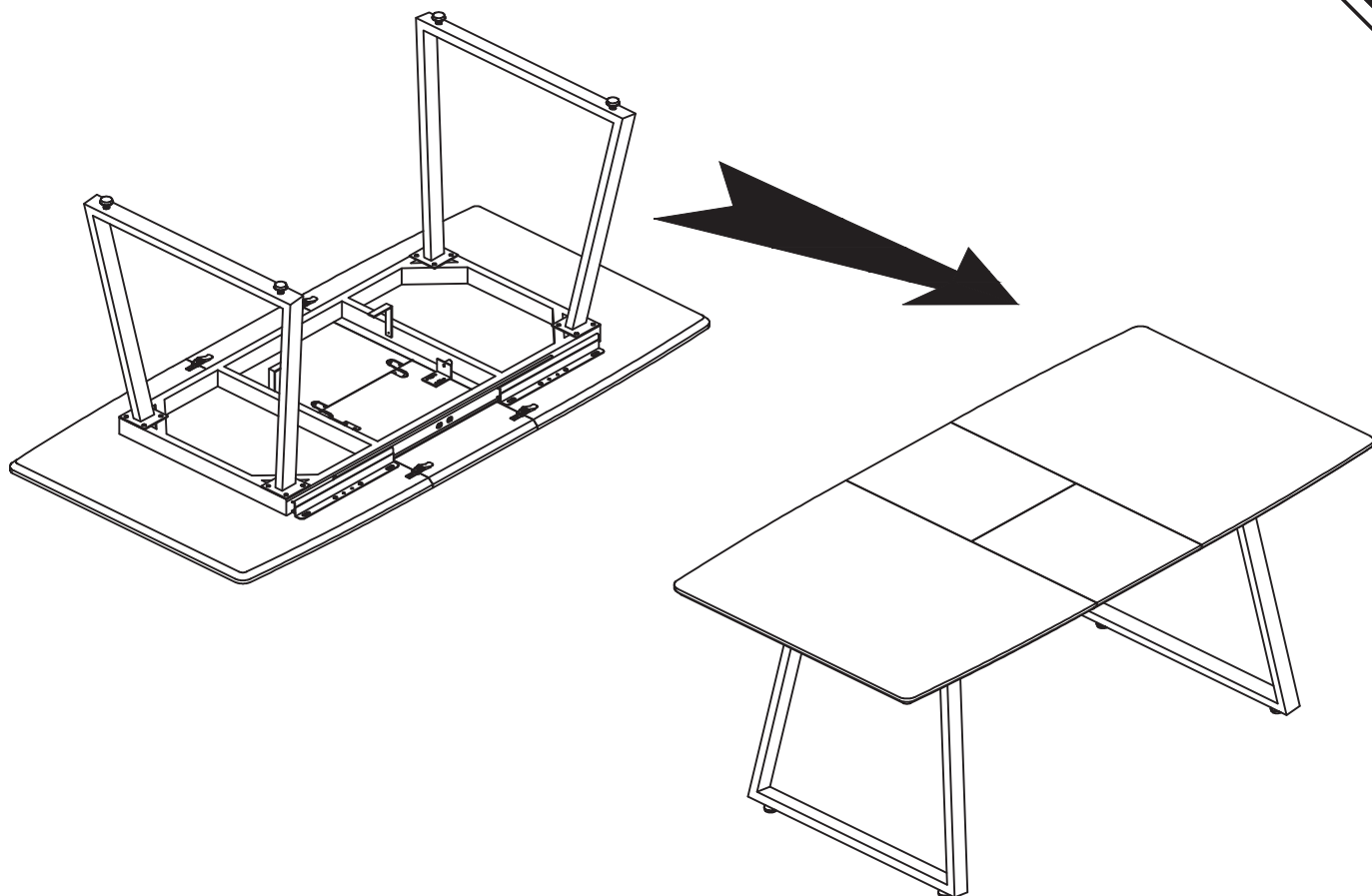

12

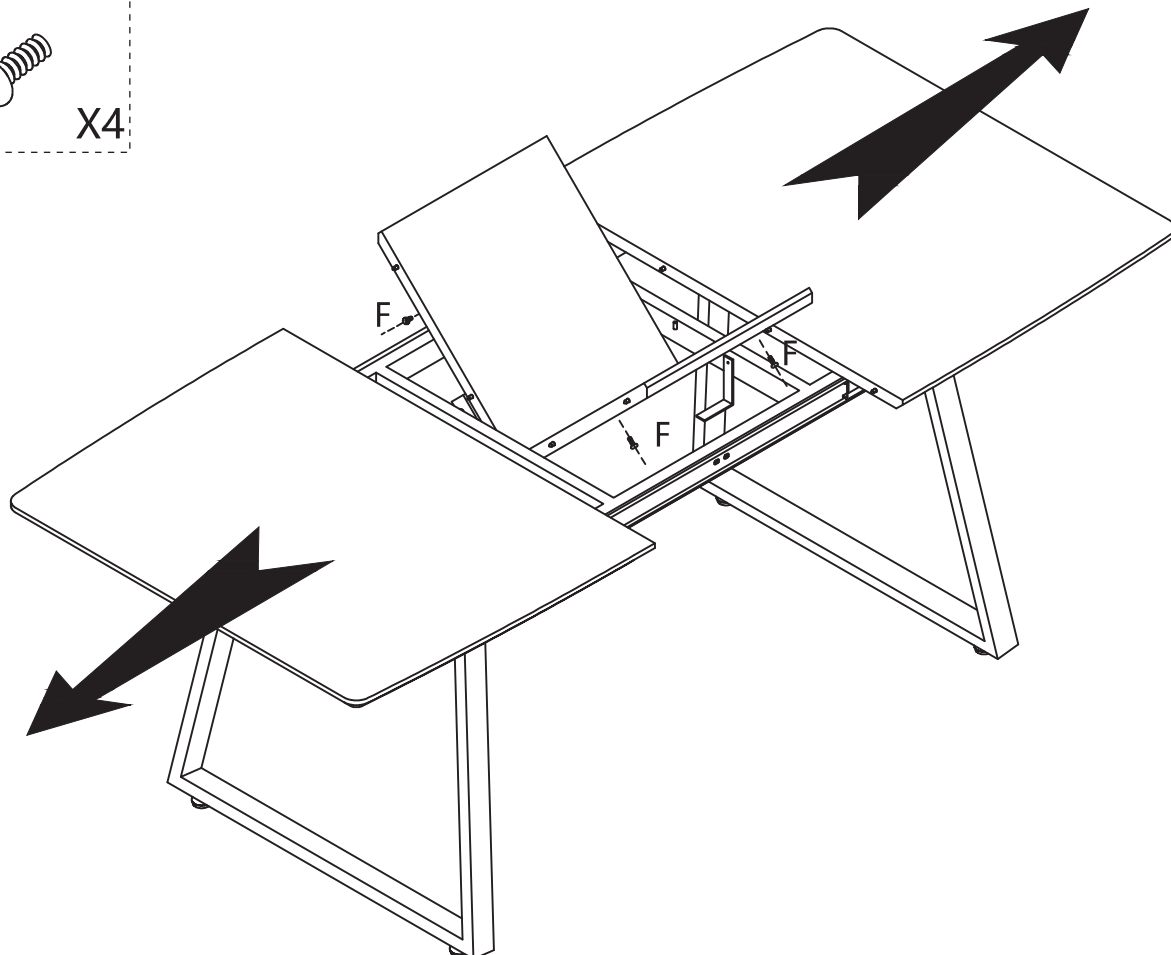
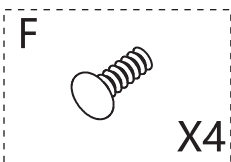

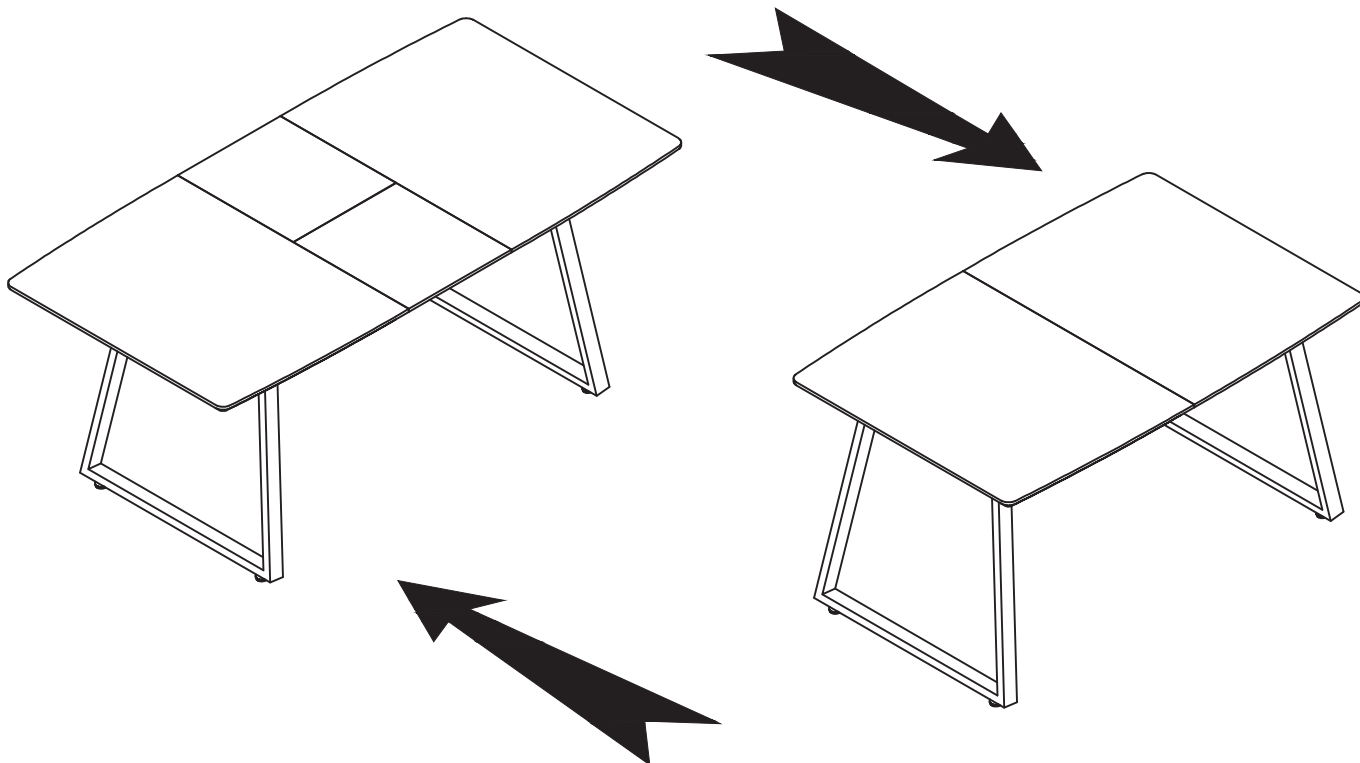
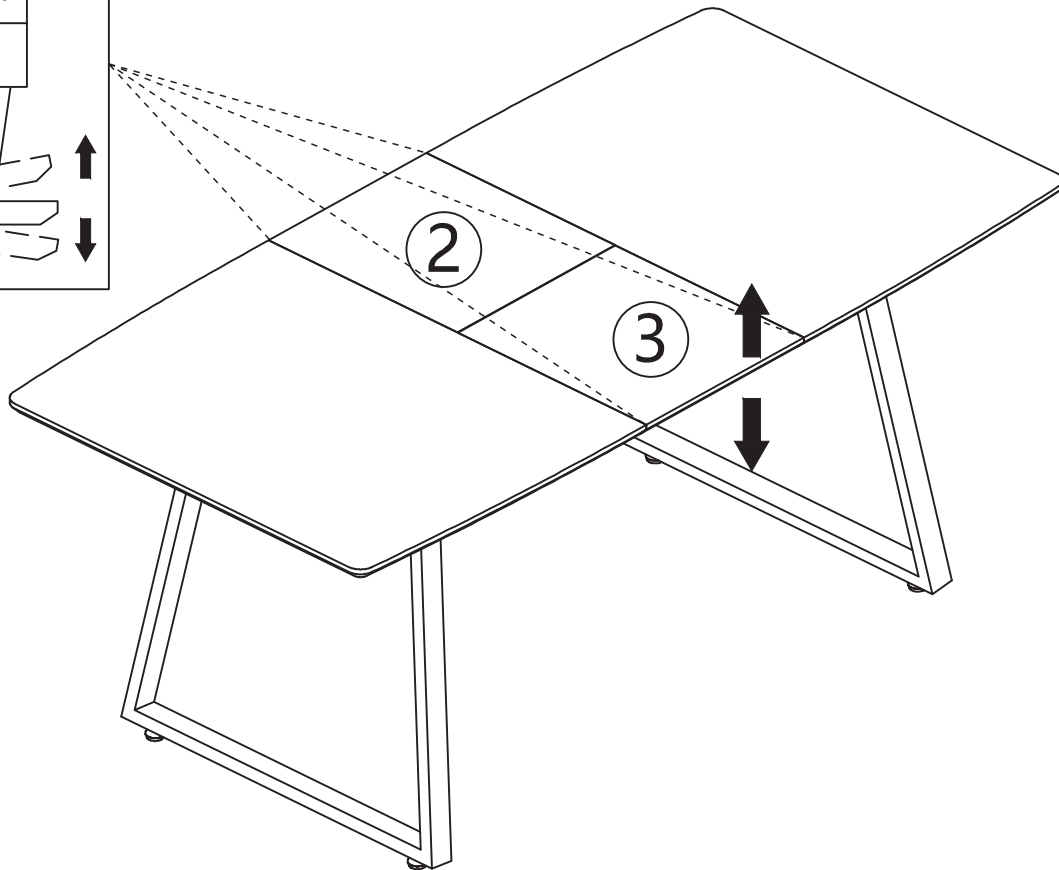
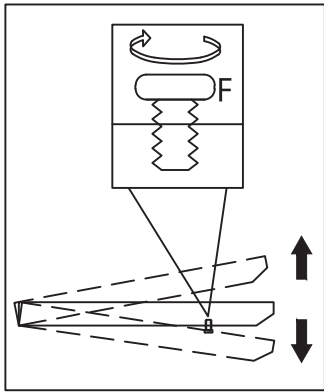

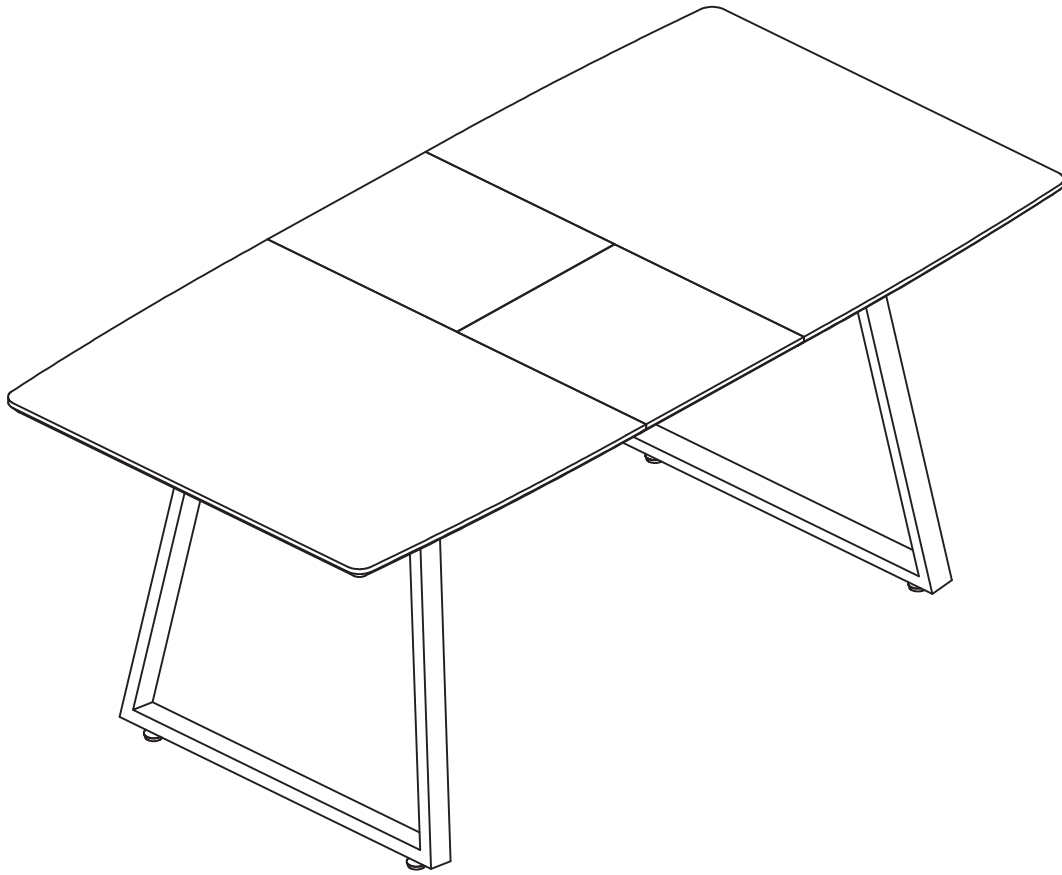

FR

**Pensez à  
donner ou recycler.**



Association

ou



Magasin

ou



Déchèterie

<https://quefairedemesdechets.fr>