



INcsb041_UK

800-101



**UK
CA**

IMPORTANT, RETAIN FOR FUTURE REFERENCE: READ CAREFULLY

USING INSTRUCTION

IMPORTANT NOTICES

When using an electrical appliance, basic safety precautions should always be followed to reduce the risk of fire, electric shock, and/or injury, including the following:

1. Read all instructions before using.
2. Remove all packing material and carefully check your ice maker to ensure it is in good condition and that there is no damage to the ice maker or power cord and plug.
3. Before using the Ice maker for the first time, please wait 2 hours after positioning it, and keep the transparent lid open for at least 2 hours
4. Pure water is not allowed to be used on this unit, spring water is recommended.
5. Ensure the voltage is compliant with the voltage range stated on the rating label, and ensure the earthing of the socket is in good condition.
6. If the supply cord is damaged, it must be replaced by the manufacturer or its service agent or a similarly qualified person in order to avoid a hazard.
7. Do not upend this product or incline it over a 45° angle.
8. To protect against risk of electric shock, do not pour water on cord, plug and ventilation, immerse the appliance in water or any other liquid.
9. Unplug the appliance after using or before cleaning.
10. Keep the appliance 8cm from other objects to ensure the good heat releasing.
11. Do not use the accessories which are not recommended by Manufacturer.
12. This appliance is not intended for use by persons (including children) with reduced physical, sensory or mental capabilities, or lack of experience and knowledge, unless they have been given supervision or

supervised to ensure that they do not play with the appliance.

13. Do not use the appliance close by flames, hot plates or stoves.

14. Do not switch on the power button frequently (ensure 5min. interval at least) to avoid the damage of compressor.

15. Metal sheet or other electric objects are not allowed to be inserted into the appliance to avoid fire and short circuit.

16. Do not use outdoors.

17. Never clean with scouring powders or hard implements.

18. Please keep the instruction manual.

19. Warning: Do not store explosive substances such as aerosol cans with a flammable propellant in this appliance.

20. This appliance is intended to be used in household and similar applications such as

- staff kitchen areas in shops, offices and other working environments;
- farm houses and by clients in hotels, motels and other residential type environments;
- bed and breakfast type environments;
- catering and similar non-retail applications

21. When positioning the appliance, ensure the supply cord is not trapped or damaged.

22. Do not locate multiple portable socket-outlets or portable power supplies at the rear of the appliance

23. The refrigerant and insulation blowing gas is flammable, when disposing of the appliance, do so only at an authorized waste disposal centre. Do not expose to flame. instruction concerning use of the appliance by a person responsible for their safety. Children should be



This symbol indicates the refrigerant R600a and the non-metallic materials of the appliance are flammable. It's a warning symbol. Warning: Risk of fire / flammable materials.



Warning: Risk of fire/flammable materials.

WARNING: When positioning the appliance, ensure the supply cord is not trapped or damaged.

WARNING: Do not locate multiple portable socket-outlets or portable power supplies at the rear of the appliance.

Children should be supervised to ensure that they do not play with the appliance.

To avoid contamination of food, please respect the following instructions:

- Opening the door for long periods can cause a significant increase of the temperature in the compartments of the appliance.
- Clean regularly surfaces that can come in contact with food and accessible drainage systems.
- Clean water tanks if they have not been used for 48 h; flush the water system connected to a water supply if water has not been drawn for 5 days.
- If the refrigerating appliance is left empty for long periods, switch off, defrost, clean, dry, and leave the door open to prevent mould from growing within the appliance.

Regarding the information pertaining to the use of the appliance, please refer to the paragraphs below.

SPECIFICATIONS

Daily ice output: 12kg / 24 hours

Ice storage capacity: 1.5L/600g

Refrigerant: R600a

Compression-type refrigeration: 220-240V/50Hz

Water tank capacity: 1.5 L

Voltage: 220-240V

Frequency: 50 Hz

Power consumption: 120 W

Max overall dimensions(W×D×H): 224X 308X283mm

N.W: 7.5kg

G.W: 8.5kg

DESCRIPTION

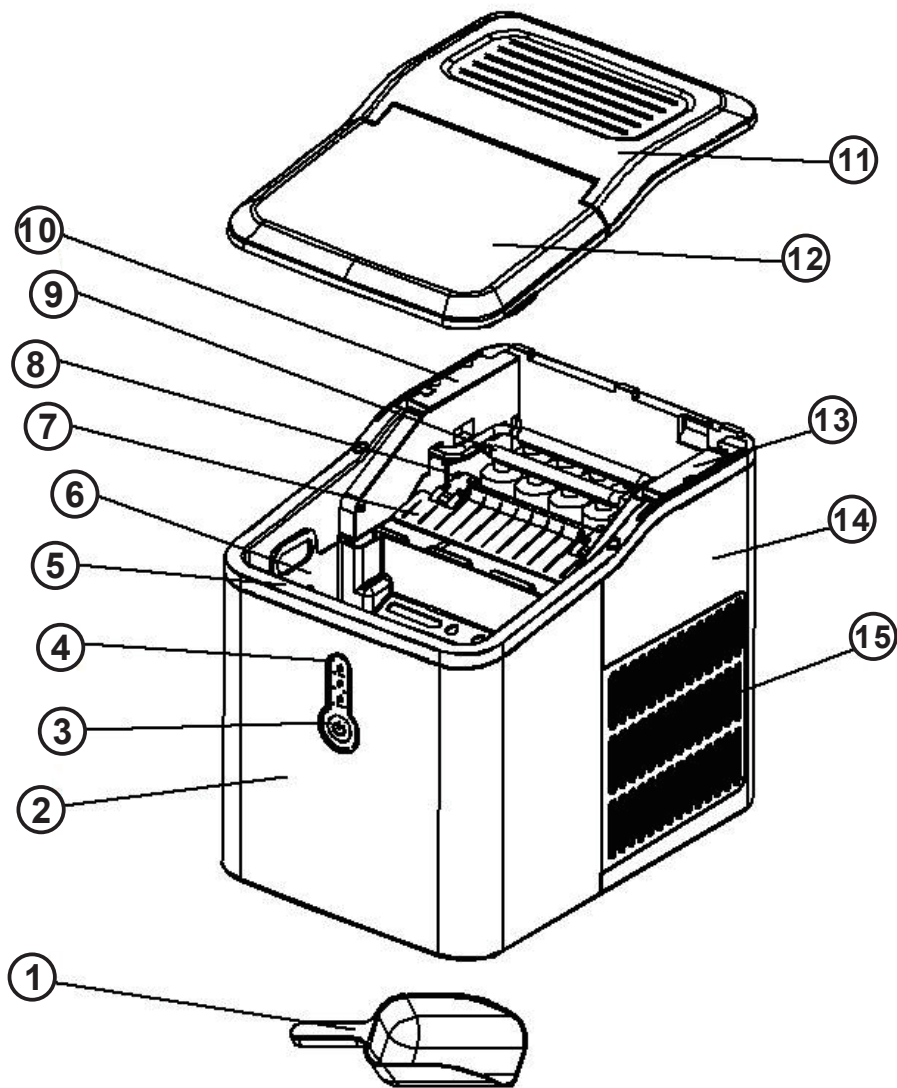

1. Micro switch support
2. Evaporator
3. Water Tray
4. Ice shovel board
5. Ice collecting tray
6. Water box
7. Control panel
8. Buttons
9. Front housing
10. Ice shovel

11. Top cover
12. Transparent lid
13. Motor Mount
14. Back housing
15. Air vent

FEATURE

- ✧ Quick ice making
- ✧ Prompt when the ice is full and water is insufficient
- ✧ Bullet ice
- ✧ 9 pcs ice can be made in eight minutes

WARNING

1. During transportation, do not tilt the machine more than 45 degrees, do not reverse the machine. This may damage the compressor and the sealing system.
2. Remove all packing materials, check the machine carefully and make sure that the machine, power cord and plug are normal.
3. The machine should be on a level surface. To ensure sufficient ventilation, the distance of the back of ice maker to the wall should be at least 150 mm, it should be away from the oven, radiator or other heat source.
4. Before using the machine for the first time, place the machine and leave the transparent cover open for at least two hours.
5. Make sure that the home voltage is consistent with the voltage indicated by the machine.
6. Distilled water is not allowed. Mineral water is recommended.

CONTROL PANEL OPERATION



ICE FULL: Ice full alarm

ADD WATER: Water shortage alarm

ICE MAKING: Ice making

1). Plug in the power, the "ICE MAKING" indicator flashes, and the machine will start the deicing function. Press the power button, the "ICE MAKING" indicator light is always on and then the ice block will be made automatically. After the ice making is completed, the deicing will be carried out, and then the ice shoveling function will be entered, and so on.

2). ADD WATER: water shortage alarm

When the "ADD WATER" light turns red, it means that there is water shortage in the water tank. You need to add water and press the power button to restart the machine.

3) ICE FULL: Ice full alarm

When the ice reaches the maximum capacity of the ice storage container, the "ICE FULL" light flashes, and the machine stops. At this time, the ice needs to be poured out. When the ice position is lower than the full sensor position, the machine will restart automatically.

4) ICE MAKING: Ice making

When this light is always on, it means that the ice maker is making ice.

OPERATING INSTRUCTIONS

Step 1

Open the lid and take out the basket and add water to the reservoir.

Note: There is a maximum scale MAX in the reservoir. The water should not exceed the MAX position. If the water exceeds the maximum scale MAX, you need to open the bottom drain plug, release the excess water, and cover with a transparent cover.

Step 2

Plug in the power and press the power button to start the machine.

CAUTION

1. The three cycles used for the first time, the ice produced is small and irregular.
3. When the ice basket is full, please take out the ice immediately, do not let the ice overflow the ice basket

CLEANING & USE GUIDANCE

1. Clean the inner liner, ice collecting tray, water box, ice shovel and evaporator frequently. When cleaning, unplug the unit and remove the ice cubes. Use a diluted solution of water and vinegar to clean the inside and the outside surface of the Ice maker. Do not spray Ice maker with chemicals or diluted agents such as acids, gasoline or oil. Rinse thoroughly before starting.
2. Keep ventilation openings in the appliance enclosure, or in the built-in structure, clear of obstruction. Do not use mechanical devices or other means to accelerate the defrosting process, other than those recommended by the manufacturer.
3. Reuse the machine after being idled for a period of time, it may not have enough water to pump for air retard, in this case, the water shortage indicator "ADD WATER" will light up, repress power button to restart the ice maker is okay.
4. To ensure the cleanness of ice, please change water for water reservoir at least once one day. If do not use for a long time, please drain the water out and clean it up.
5. If the compressor takes a strike action for shortage water, fully water or interruption of power supply, it will delay for 3mins to start up after restarted.
6. Always use fresh water before starting ice production either at initial installation or after a long shut-off period.

TROUBLESHOOTING

1. Please note, if a power failure occurs due to disconnection of the power cord, or the power button has been pushed off during an ice making cycle, small ice chips may formed and lodge in the automatic shovel causing it to jam. If this occurs, the ice chips may be removed by disconnecting the power cord and gently pushing the shovel to the rear of the cabinet and removing the ice chips, then restarting.

2. Please check if the water reservoir is flat when the ice shovel can not remove the ice to ice basket. If not, please push the ice shovel gently by finger, then press POWER button to restart.

PROBLEM	POSSIBLE CAUSE	SUGGESTED SOLUTIONS
The compressor works abnormally with a buzzing noise	The voltage is lower than recommended	Stop the ice maker and do not restart until the voltage is normal.
Water shortage indicator light is on	1. There is no water 2. The pump is full of air	1. Add to some water until it reaches MAX position 2. Press POWER button to restart
Indicator lights on display are not on	Blown fuse/ No power	Replace fuse / Turn power on
The ice made is too large and with pieces sticking together.	Ice of previous cycles left in the water tray	Take out the ice under the standby state
The ice making process was correct, but no ice came out?	1. The compressor has no refrigerant 2. Compressor damaged	Call the service hotline

	3. Fan motor damaged	
All indicators twinkle simultaneously	1. Water tray is blocked by ice cube 2. The motor is stuck, or the motor falls off, or the motor is damaged 3. Micro switch damaged	Unplug the power to take out the ice which blocking the tray, then plug the power and press the POWER button, the machine will restart 3mins later.
The machine has been working, but the water has been warming	Solenoid broke down	Replace the solenoid valve
When the ice is full, the machine does not display the ICE FULL Icon	1. Ice full sensor damaged Solar light interference	1. Replace the ice full sensor 2. Making ice indoor 3. Call the service hotline

1.If the power cord is damaged; it must be replaced by the manufacturer, its service agent or a similarly qualified person in order to avoid a hazard.

2.Fill with potable water only.

3.It is normal for the compressor and condenser surface to reach temperatures between 70°C and 90°C during operation and surrounding areas may be very hot.

4.Due to fast freezing, ice cubes may opaque. This is air trapped in the water and will not affect quality or taste of ice.

5.This appliance is not intended for use by persons (including children) with reduced physical, sensory or mental capabilities or lack of experience and knowledge unless they have been given supervision or instruction concerning use of the appliance by a person responsible for their safety.

6.Children should be supervised to ensure that they do not play with the appliance.

7.Do not immerse in water.

Correct Disposal of this product



This marking indicates that this product should not be disposed with other household wastes throughout the EU. To prevent possible harm to the environment or human health from uncontrolled waste disposal, recycle it responsibly to promote the sustainable reuse of material resources. To return your used device, please use the return and collection systems or contact the retailer where the product was purchased. They can take this product for environmental safe recycling.

US



001-877-644-9366
customerservice@aosom.com

CA



001-855-537-6088
customerservice@aosom.ca

UK



0044-800-240-4004
enquiries@mhstar.co.uk

DE



0049-(0)40-88307530
service@aosom.de

FR



0033-1-84166106
contact@aosom.fr

ES



0034-931294512
atencioncliente@aosom.es

IT



0039-0249471447
clienti@aosom.it