

EN IMPORTANT, RETAIN FOR FUTURE REFERENCE: READ CAREFULLY.

FR IMPORTANT: A LIRE ATTENTIVEMENT ET À CONSERVER POUR CONSULTATION ULTÉRIEURE.

ES IMPORTANTE, LEA Y GUARDE PARA FUTURAS REFERENCIAS.

DE „, WICHTIG! SORGFÄLTIG LESEN UND FÜR SPÄTER NACHSCHLAGEN AUFBEWAHREN.“

IT IMPORTANTE! CONSERVARE IL PRESENTE MANUALE PER FUTURO RIFERIMENTO E LEGGERLO ATTENTAMENTE.

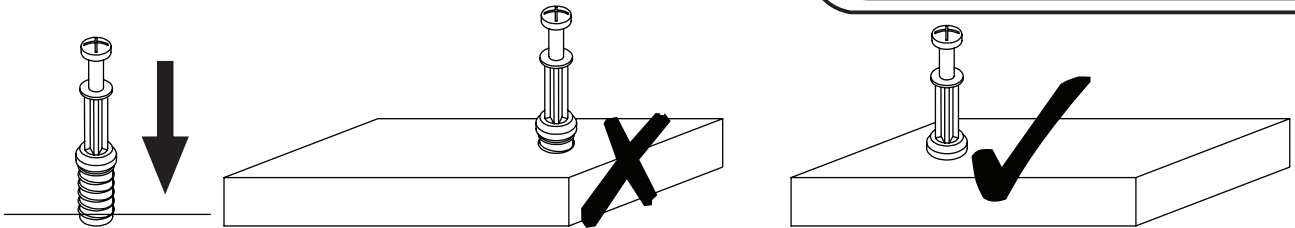

EN_QUICKFIT: Tighten quickfit until shoulder is flush with panel. Do not overtighten or undertighten.

FR_RACCORD RAPIDE: Faites serrer le raccord rapide jusqu'à ce que l'épaulement soit parfaitement encastré dans le panneau. Il ne faut ni trop serrer ni insuffisamment serrer.

ES_QUICKFIT: Apriete quickfit hasta que el hombro se descargue con el panel. NO lo sobreapriete ni lo apriete poco.

DE_QUICKFIT: Ziehen Sie den Quickfit fest, bis die Schulter mit der Platte bündig ist. Bitte nicht zu fest oder zu schwach anziehen.

IT_MONTAGGIO RAPIDO: Stringere il montaggio rapido fino a quando la spalla è a filo con il pannello, non stringere troppo o troppo poco.

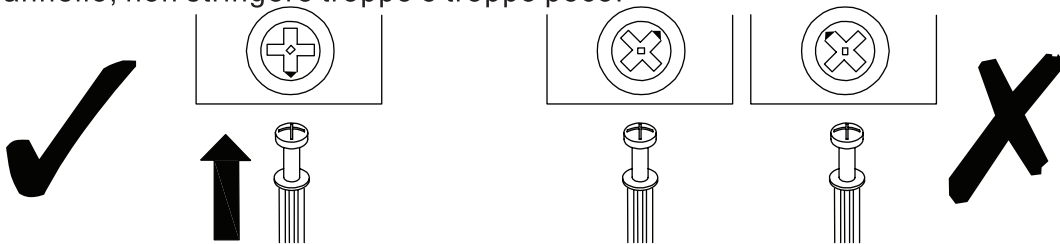

EN_CAM LOCK: When fitting cam lock, ensure starting position is correct before you insert connecting quickfit.

FR_SERRURE BATTEUSE: Avant d'insérer la serrure batteuse, veillez à la bonne orientation avant d'insérer le raccord rapide.

ES_CIERRE DE LA CÁMARA: Cuando instale el cierre de la cámara, asegúrese de que la posición de inicio es correcta antes de que inserte el quickfit conector.

DE_CAM-LOCK: Achten Sie bei der Montage des Cam-Locks auf die richtige Ausgangsposition, bevor Sie den Quickfit einsetzen.

IT_BLOCCAGGIO A CAMMA: Quando si monta il bloccaggio a camma, assicurarsi che la posizione iniziale sia corretta prima di inserire il montaggio rapido di collegamento.

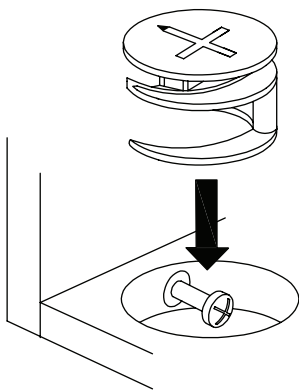

EN_Quickfit head should be in the centre of the cam lock when the two panels are joined.

Cam lock should be inserted before quickfit.

FR_Lorsque les deux panneaux sont assemblés, la tête du raccord rapide doit reposer au centre de la serrure batteuse. Il faut insérer la serrure batteuse avant le raccord rapide.

ES_El cabezal del quickfit debe estar en el centro del cierre de la cámara cuando se unan los dos paneles.

Se debe insertar el cierre de la cámara antes que el quickfit.

DE_Der Quickfit-Kopf sollte sich in der Mitte des Cam-Locks befinden, wenn die beiden Platten zusammengefügt sind. Der Cam-Lock sollte vor dem Quickfit eingesetzt werden.

IT_La testa del montaggio rapido deve trovarsi al centro del bloccaggio a camma quando i due pannelli sono uniti.

Il Bloccaggio a Camma deve essere inserito prima del montaggio rapido.

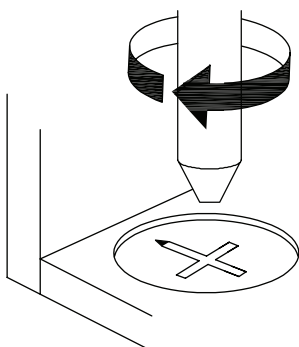

EN_Turn cam lock clockwise to tighten.









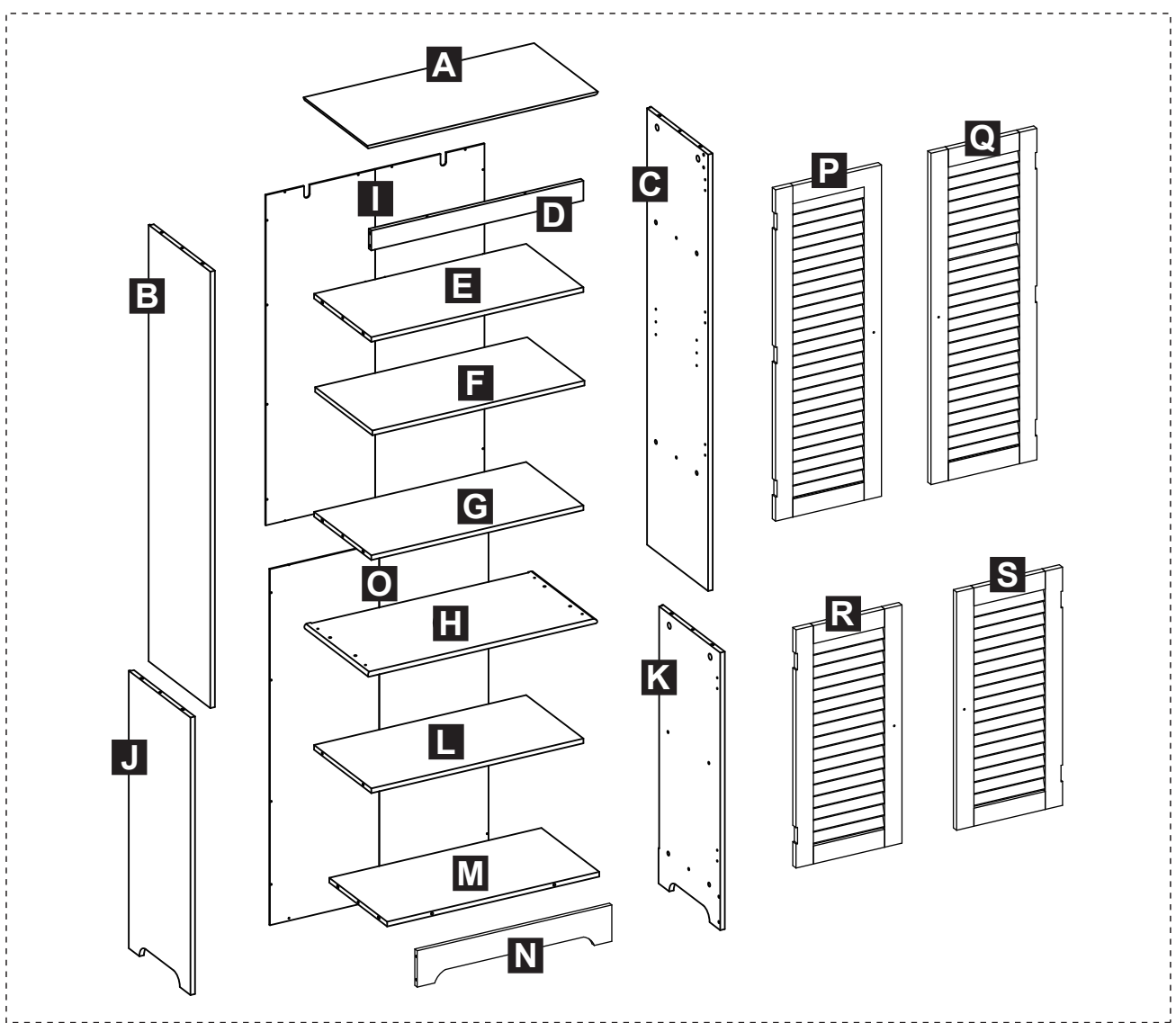

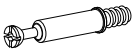



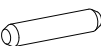

FR_Faites tourner la serrure batteuse dans le sens des aiguilles d'une montre pour la resserrer.

ES_Gire el cierre de la cámara en sentido horario para apretarlo.

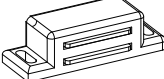
DE_Drehen Sie den Cam-Lock im Uhrzeigersinn, um ihn festzuziehen.

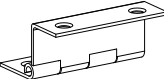
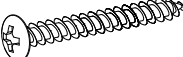
IT_Ruotare il bloccaggio a camma in senso orario per stringere.



 1 x 20 +2 (spare)	 5 x 44 M3*12 +2 (spare)	 9 x 2 M4*10 +1 (spare)	 13 x 34 M3*12 +2 (spare)
 2 x 20 +2 (spare)	 6 x 6 M4*35 +1 (spare)	 10 x 4 M4*18 +1 (spare)	 14 x 2 +1 (spare)
 3 x 28 M6*30 +2 (spare)	 7 x 4	 11 x 2	 15 x 2
 4 x 10	 8 x 2 M4*50 +1 (spare)	 12 x 4	 16 x 4 +1 (spare)
 17 x 4 M3*14 +1 (spare)			

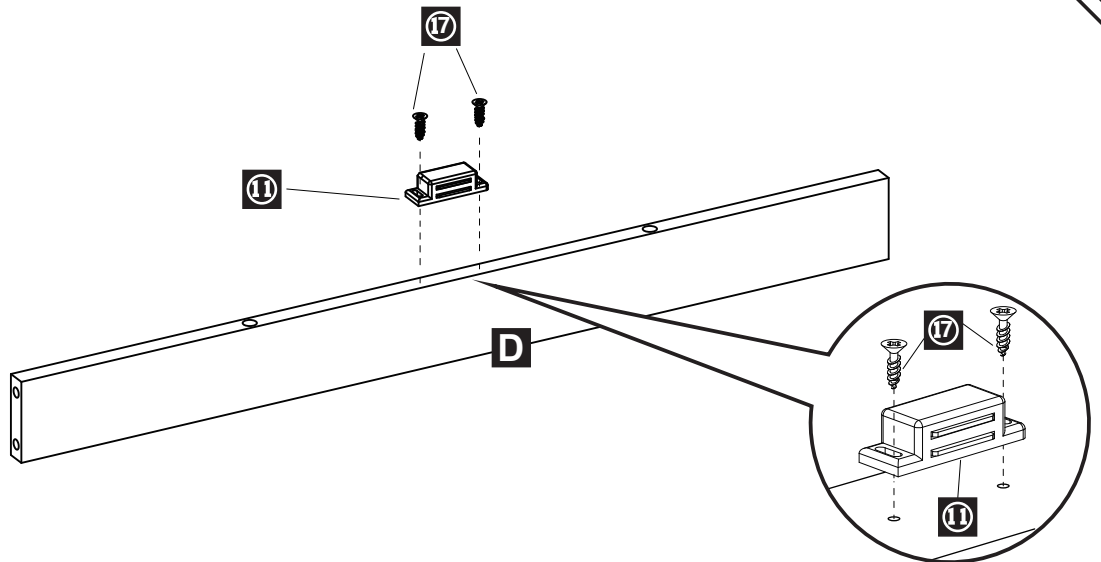
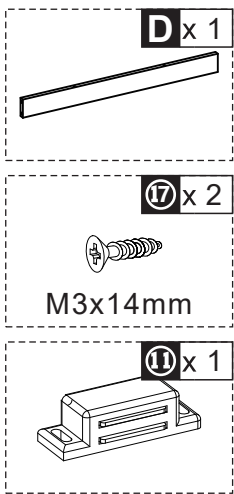
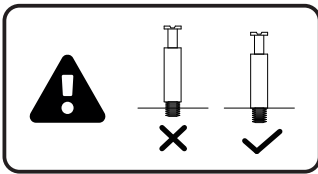
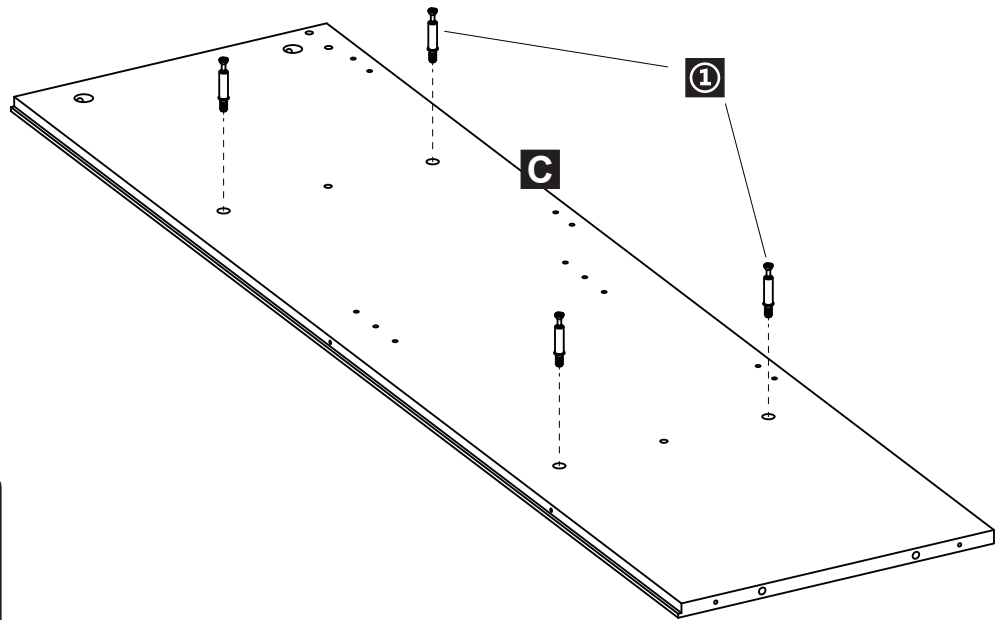
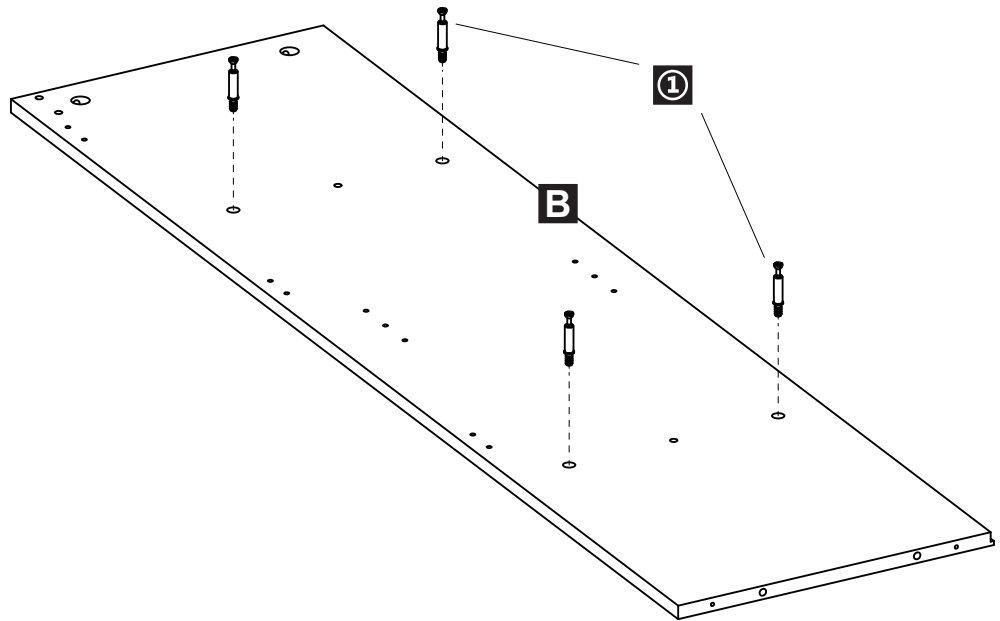
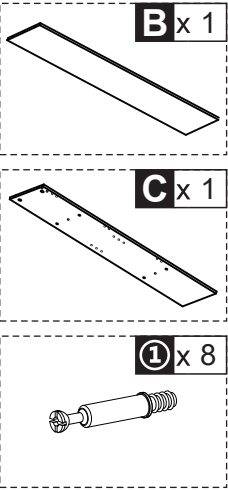

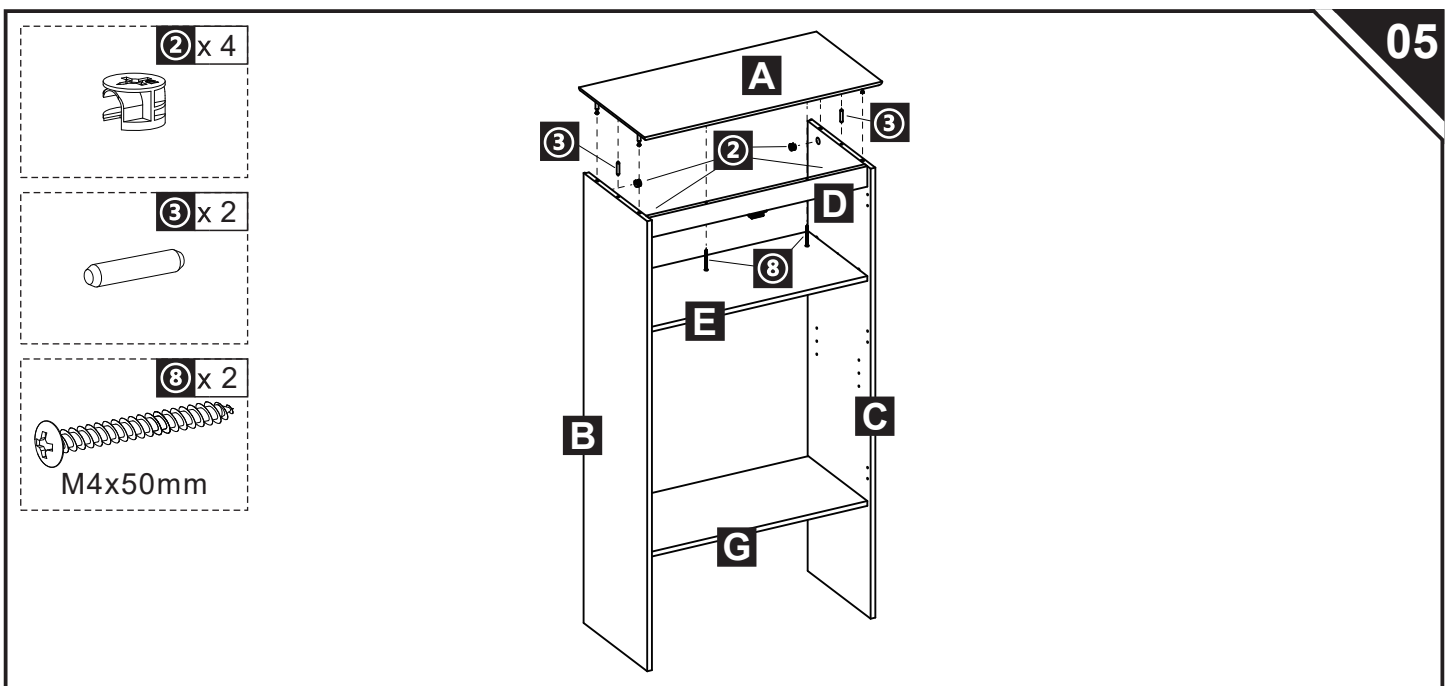
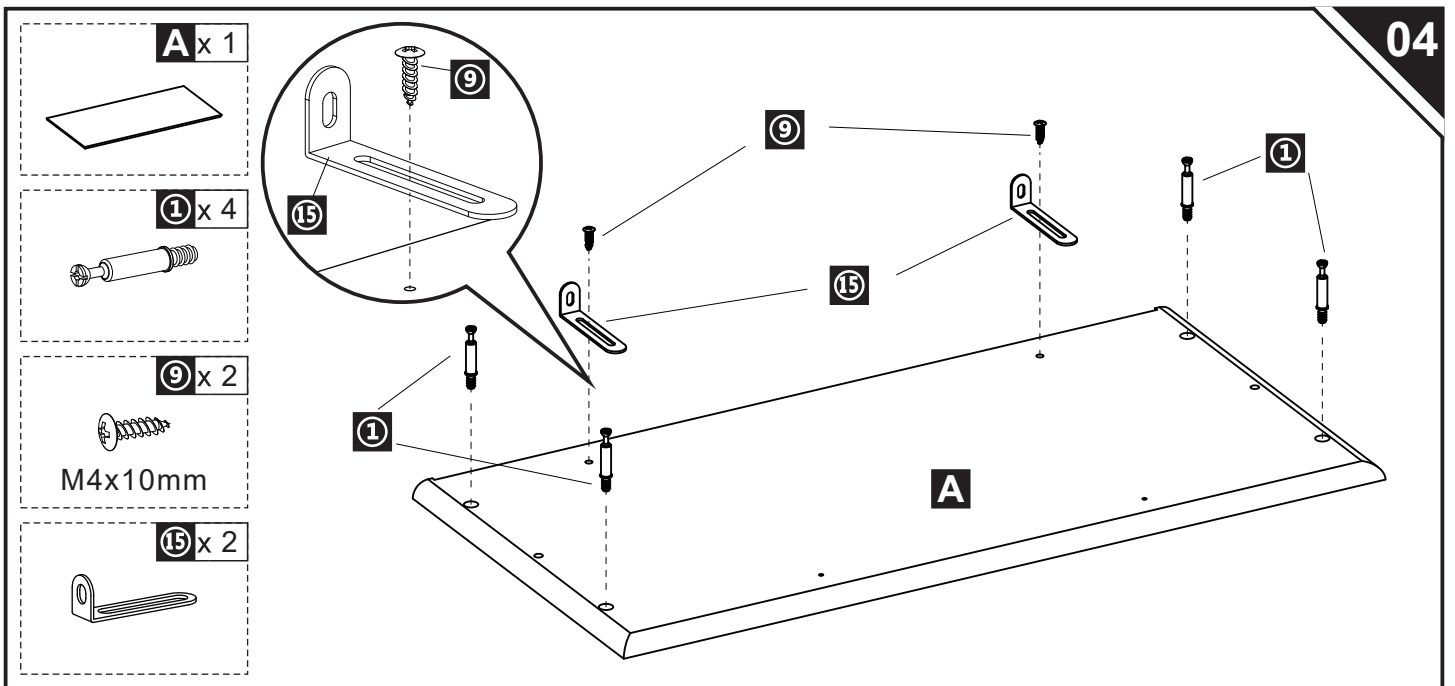
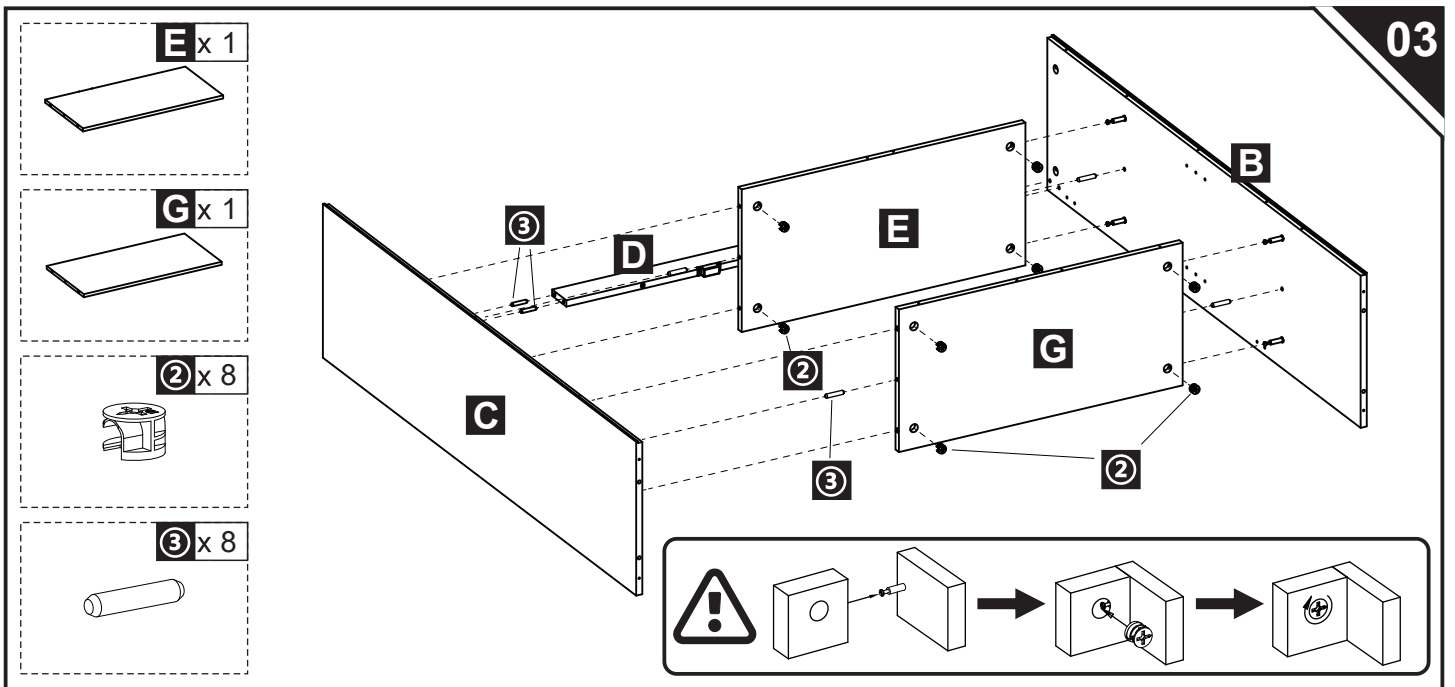

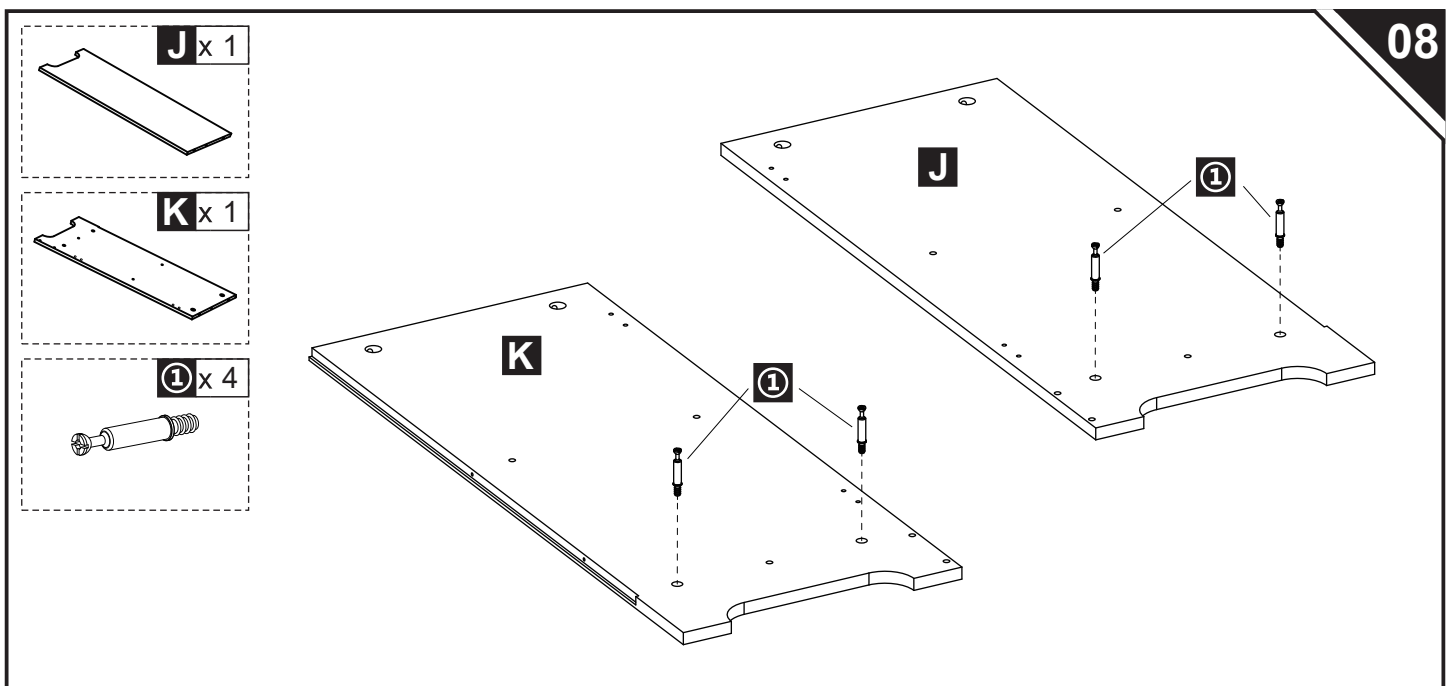
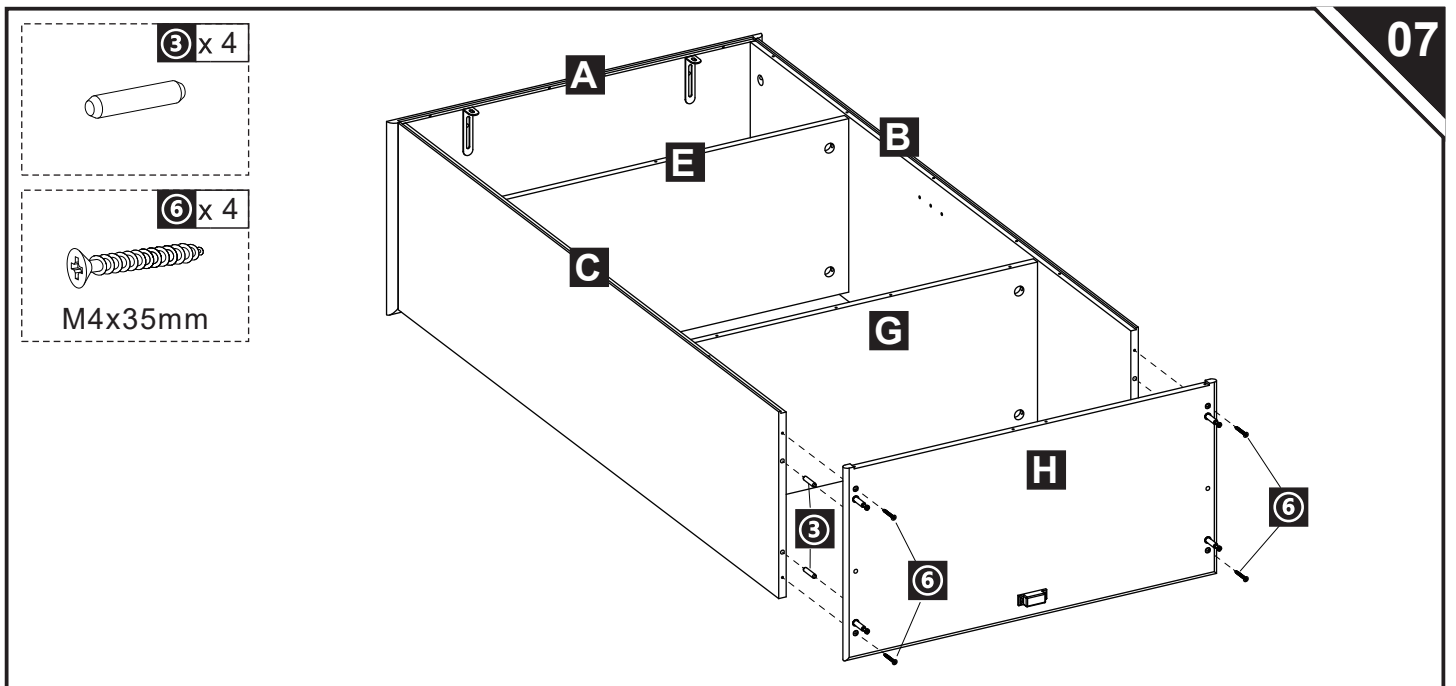
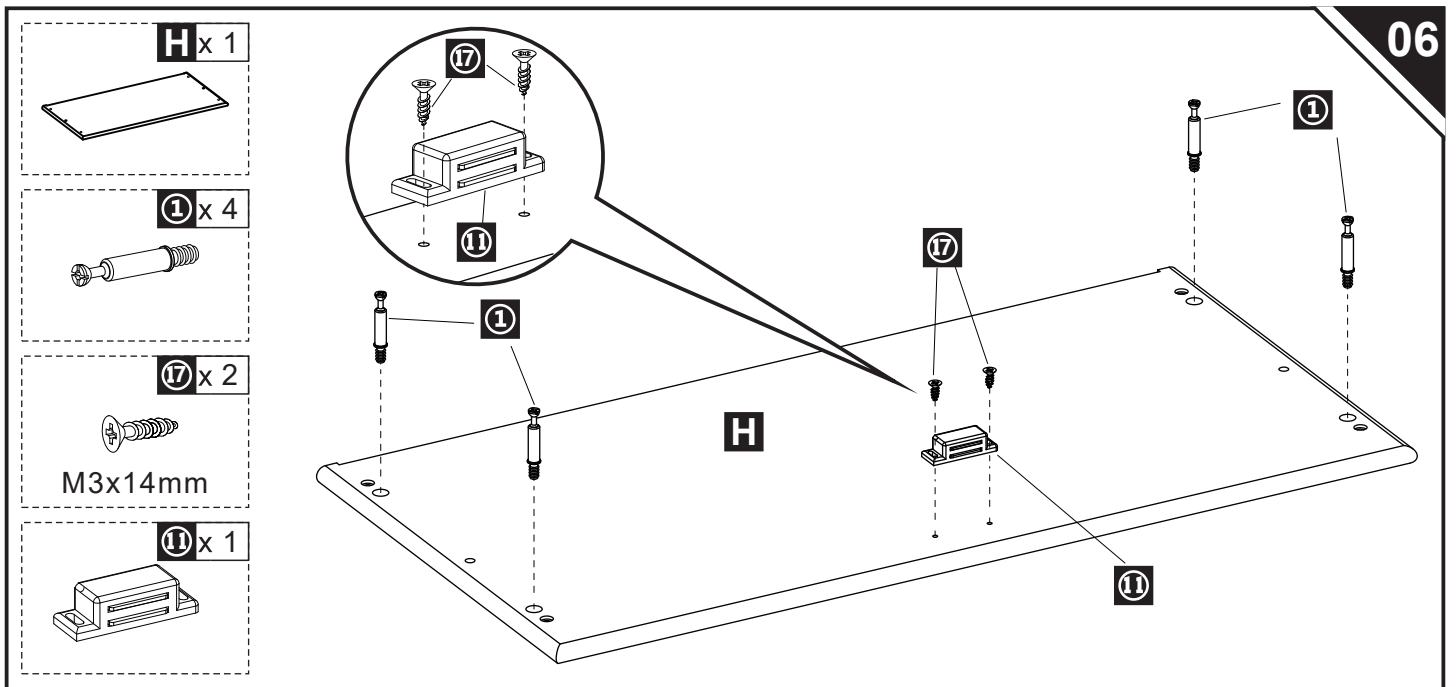

M x 1



N x 1



③ x 2

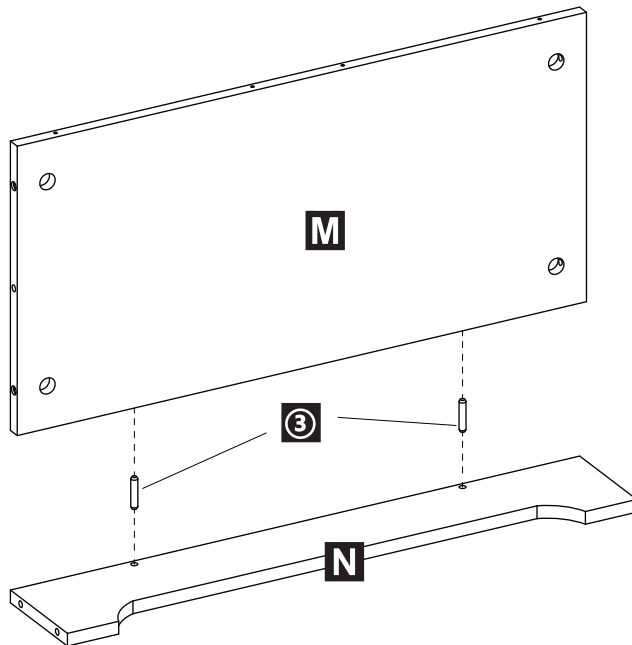
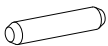

L x 1



② x 4



③ x 10

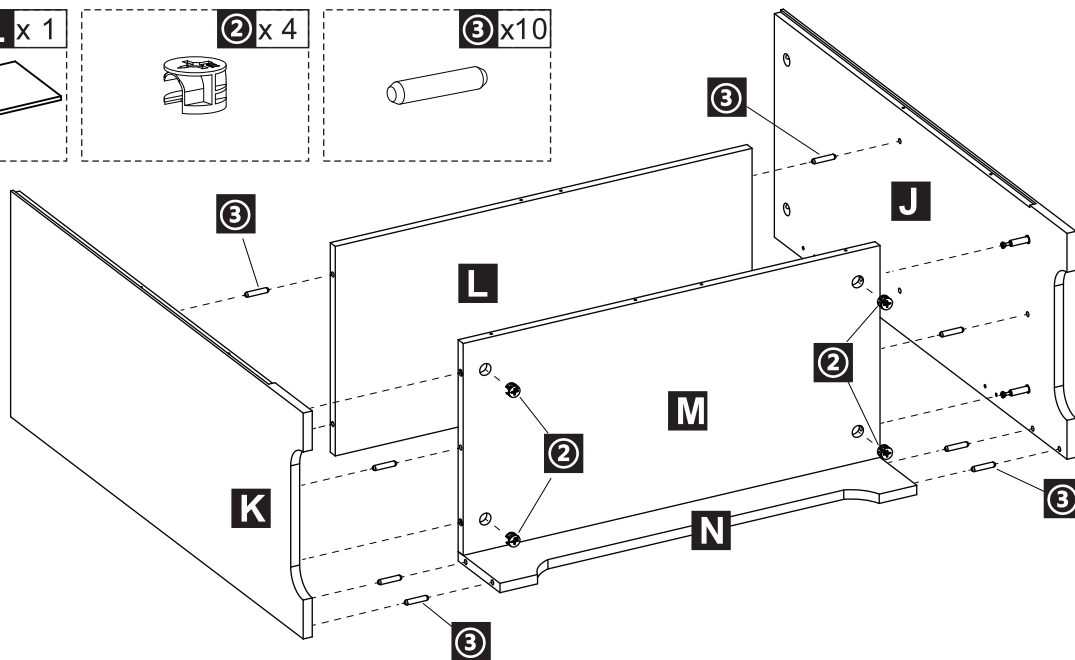
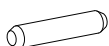

② x 4



③ x 2

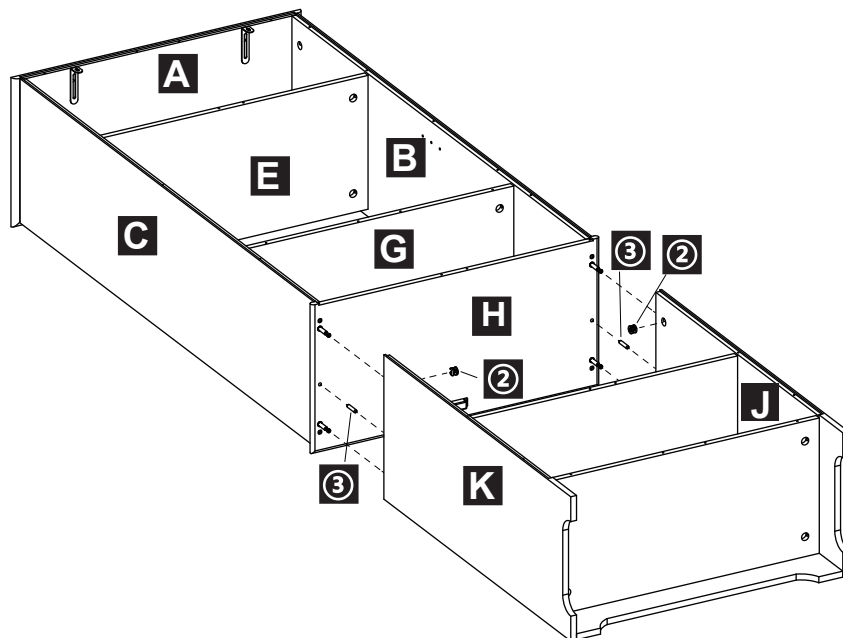

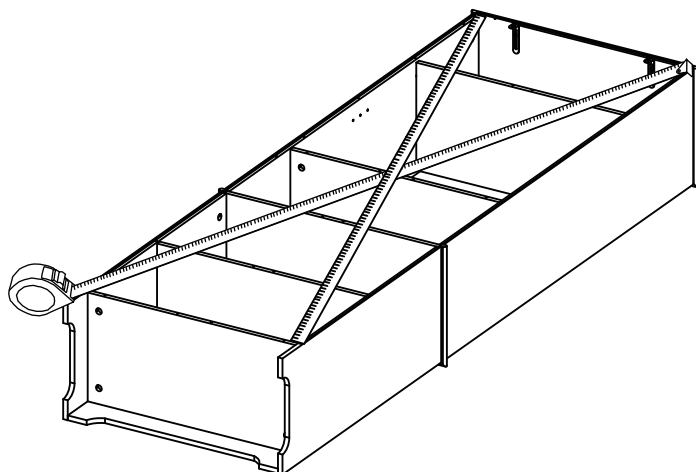
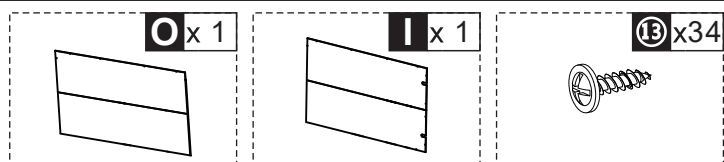

EN: please use the tape to measure this two diagonal line to make sure they are in same dimension then fixed the back panels(① & ②) to product with screws ⑬ .

FR: Veuillez utiliser le ruban à mesurer pour vous assurer que les deux lignes diagonales ont la même dimension. Ensuite, fixez les panneaux arrière ① & ② au produit avec les vis ⑬ .

ES: Utilice una cinta métrica para medir las dos líneas diagonales para asegurarse de que sean de la misma dimensión, luego utilice los tornillos para fijar los paneles traseros ① & ② al producto ⑬ .

DE: Messen Sie die beiden diagonalen Linien mit einem Maßband, um sicherzustellen, dass sie die gleichen Abmessungen haben, und befestigen Sie dann die Rückwände ① & ② am Produkt anhand den Schrauben ⑬ .

IT: Si prega di utilizzare il metro a nastro per misurare queste due linee diagonali per assicurarsi che siano nella stessa lunghezza, e poi fissare i pannelli posteriori ① & ② per completare l'assemblaggio del prodotto con le viti ⑬ .

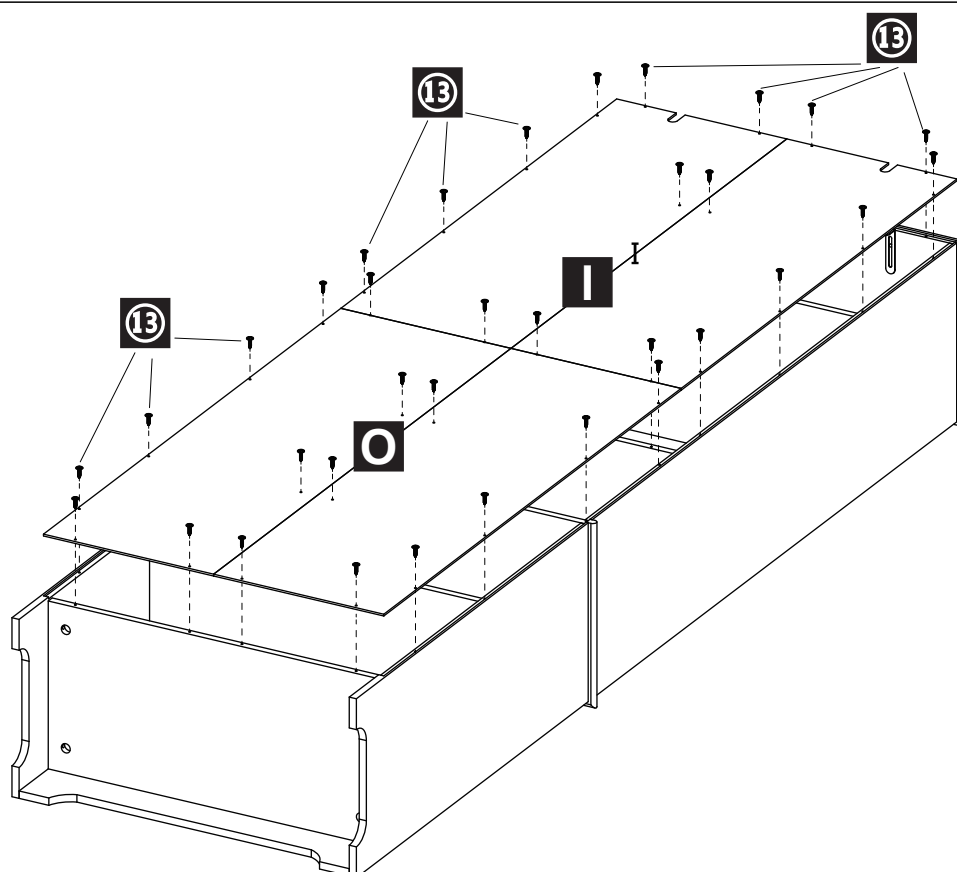

13

14

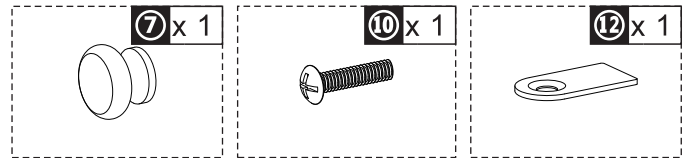
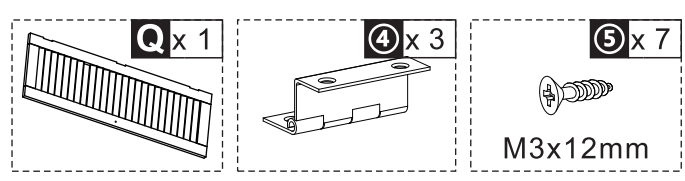
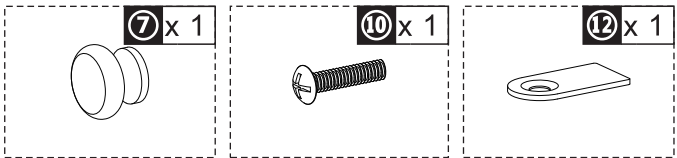
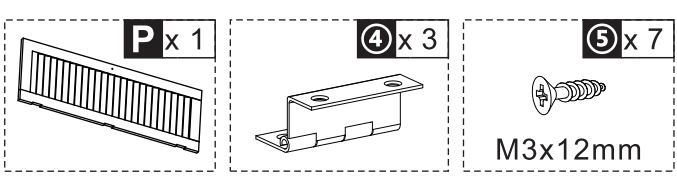
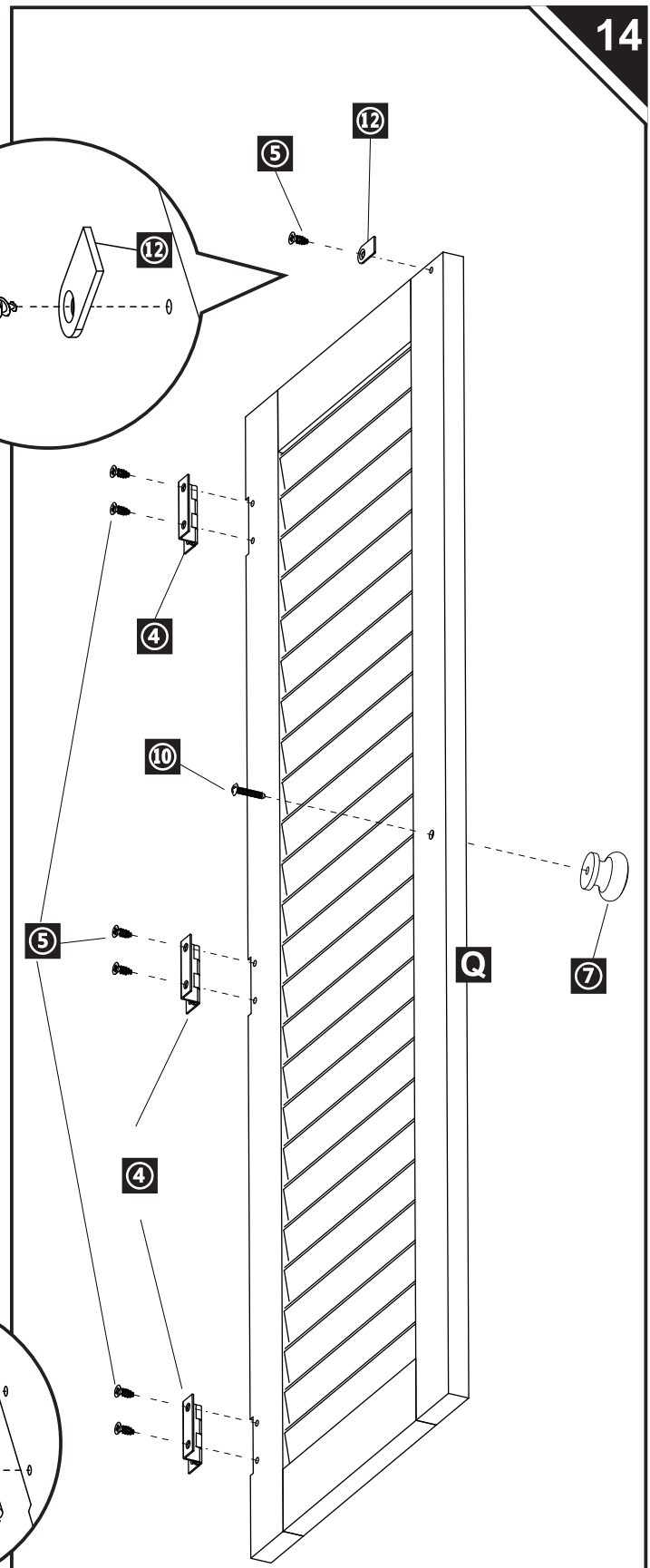
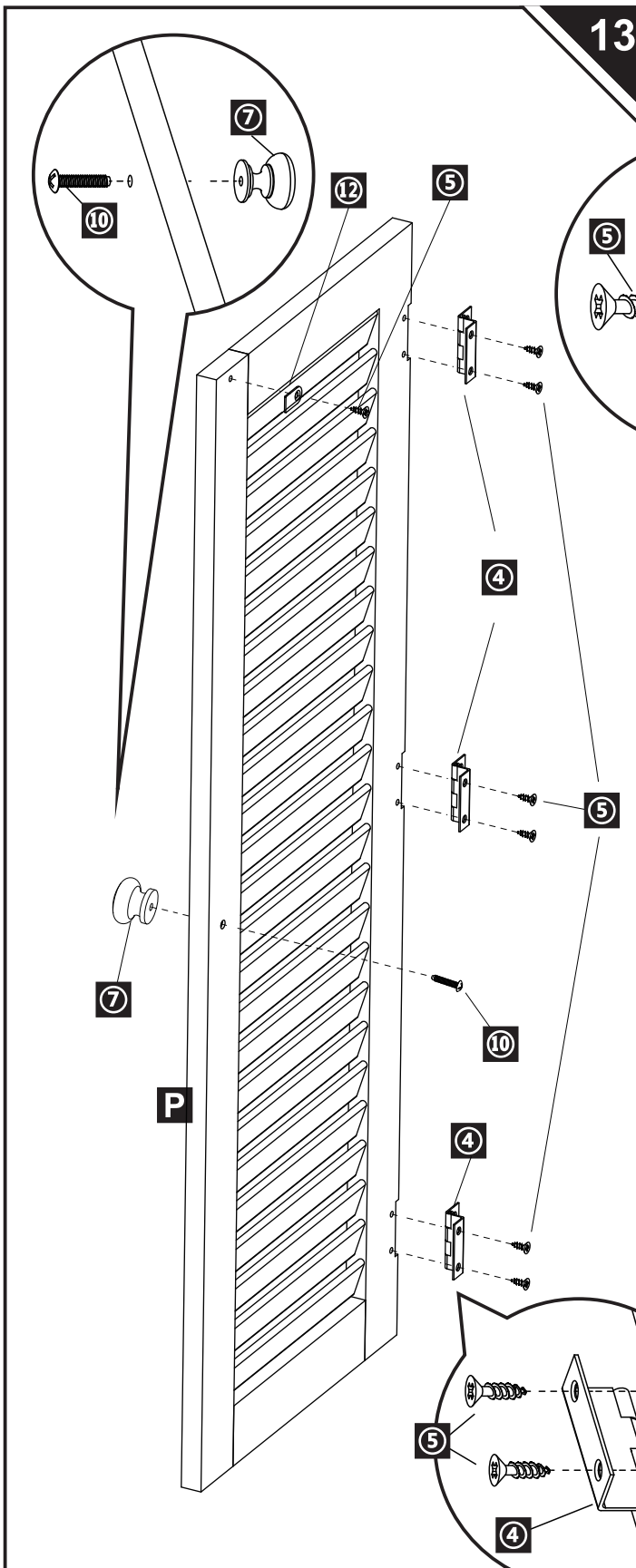

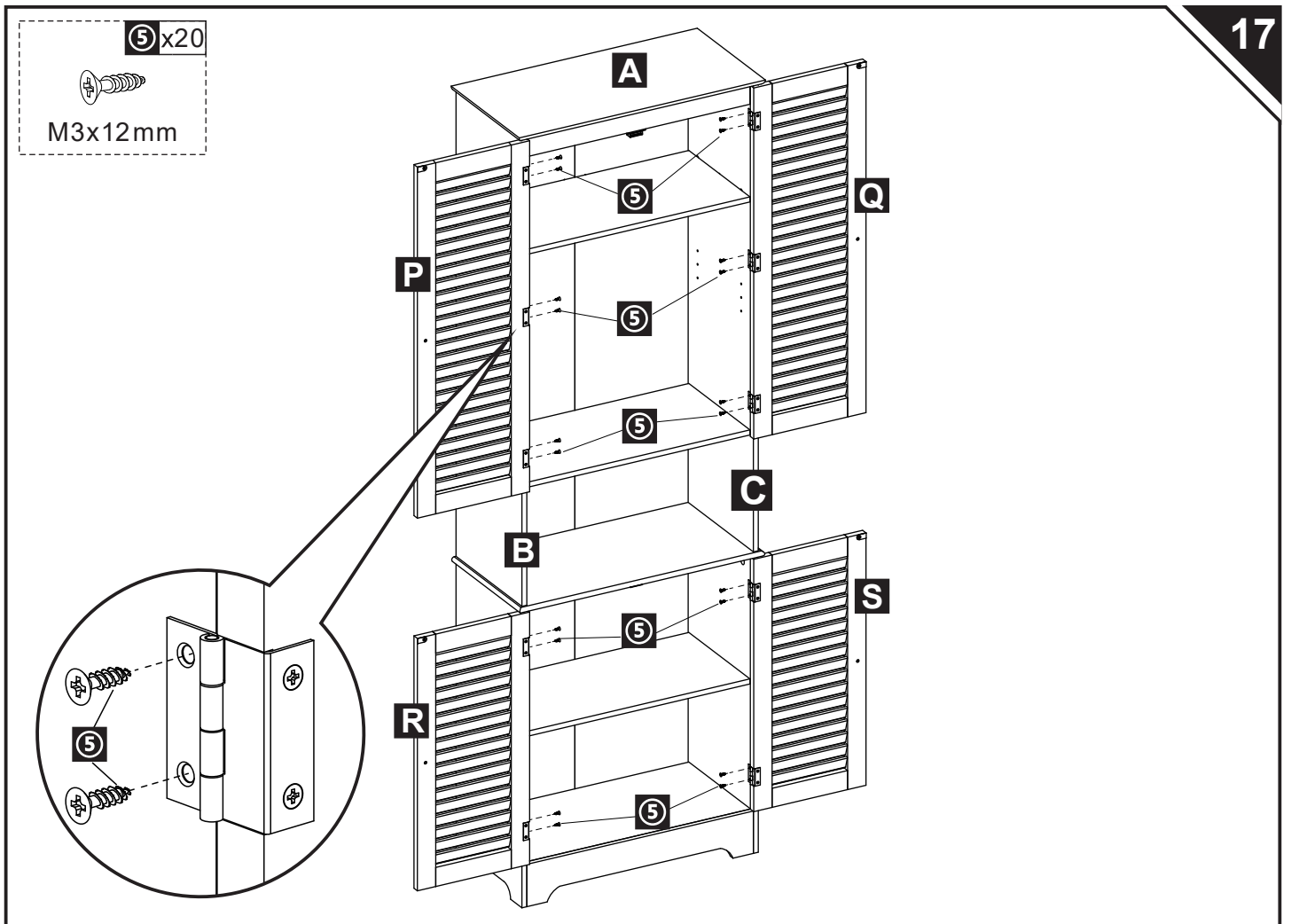
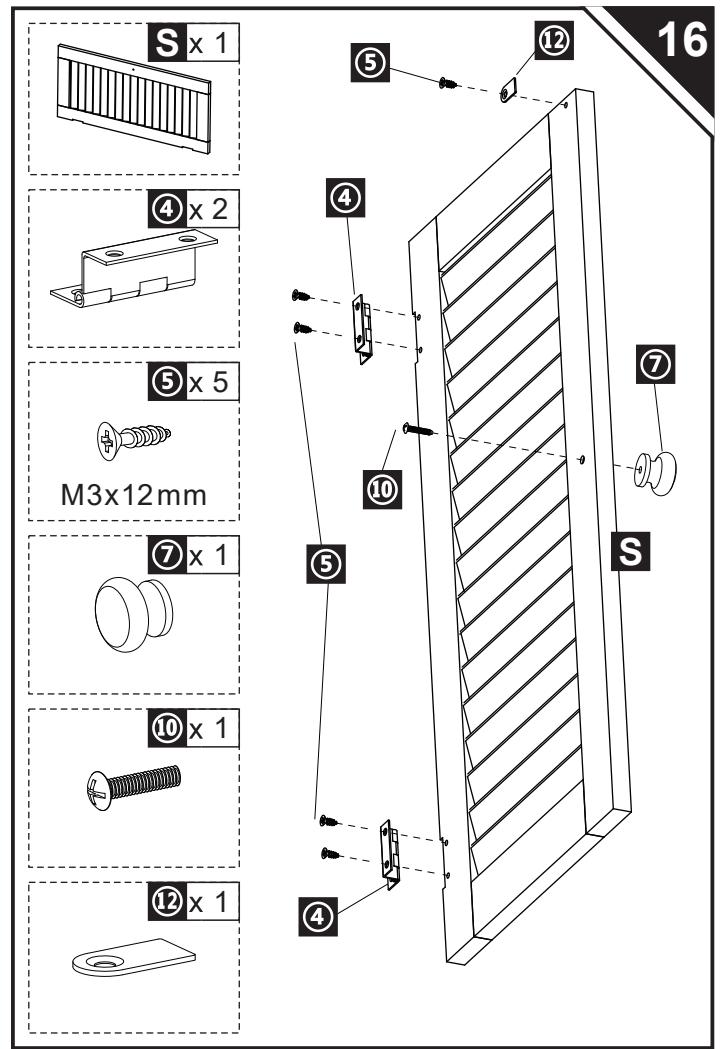
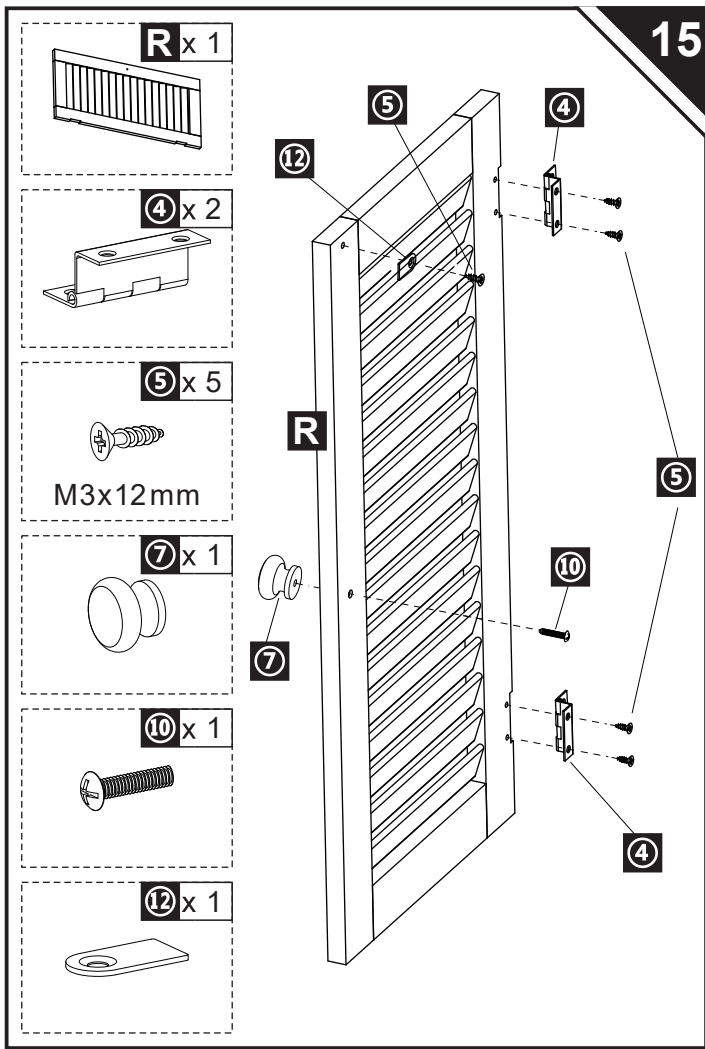

F x 1



6 x 2



M4x35mm

14 x 2

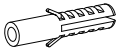

16 x 4

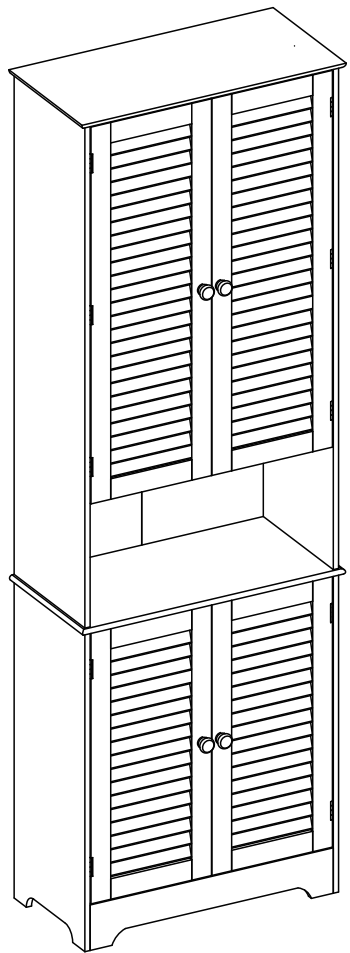
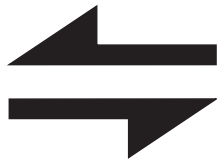
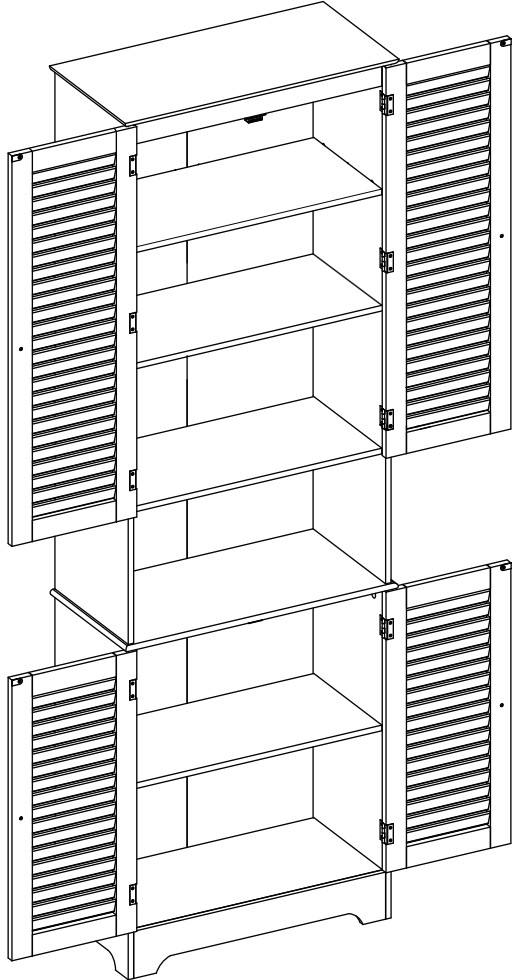
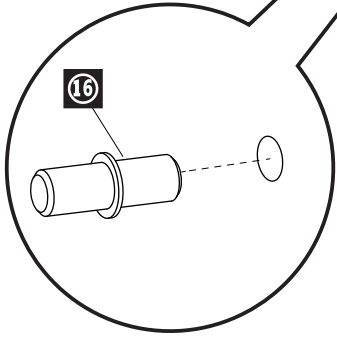
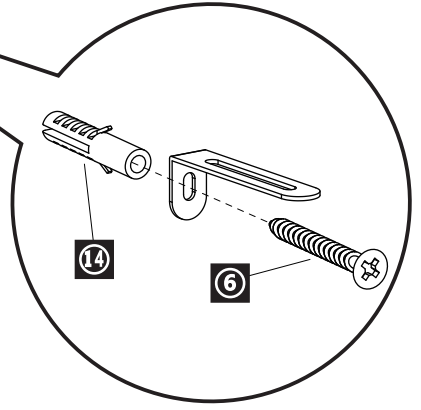
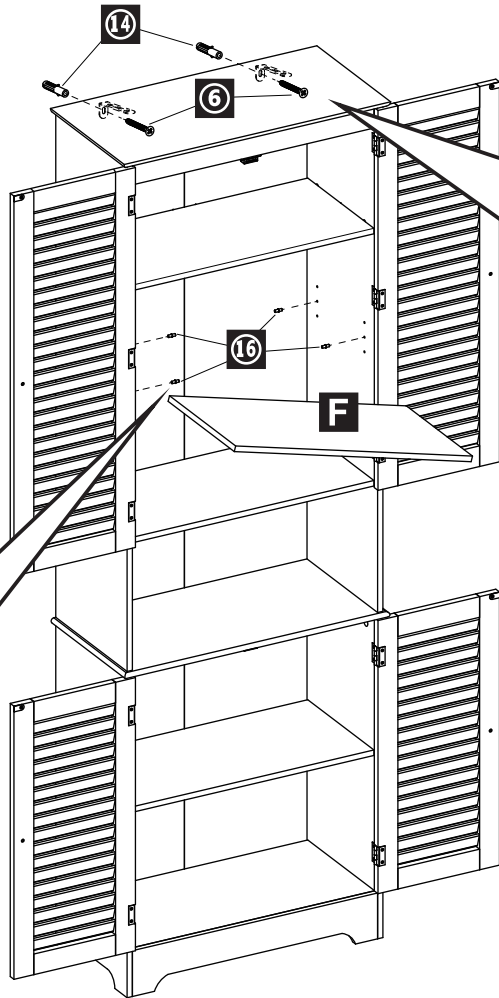
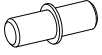



FR

**Pensez à
donner ou recycler.**



Association

ou



Magasin

ou



Déchèterie

<https://quefairedemesdechets.fr>