

Agility Slalom

Picture 1:

In the first step, you should build an alley, in which the dog can go through without contact. At the beginning, you can direct the dog with a leash through the alley. Then you can motivate the dog with a ball and you can run by changing left and right side of the alley. Gradually you should send the dog to the alley at different angles. Once the dog runs into the alley, you can confirm with the order "Slalom".

Picture 2:

If everything runs smoothly, get started now gradually continuing to push away the rows from each other until the dog touches the rods as it passes through.

Picture 3:

When this works, you can also plug in a straight slalom.

ATTENTION!

It is very important that you not over train your dog. Particularly the puppies and young dogs have only very short concentration time.

If your dog has a problem with the steps, you might have proceed to fast. You should go back with the steps until the dog has mater this step.

Attention that the training should always end with a positive experience.

Building

1. Turn the pegs in the slalom poles and pull off the protective cap.

2. Use the guide to align the poles in a line. The colorful threads on the string indicate the distance before (wm level is 60 cm)

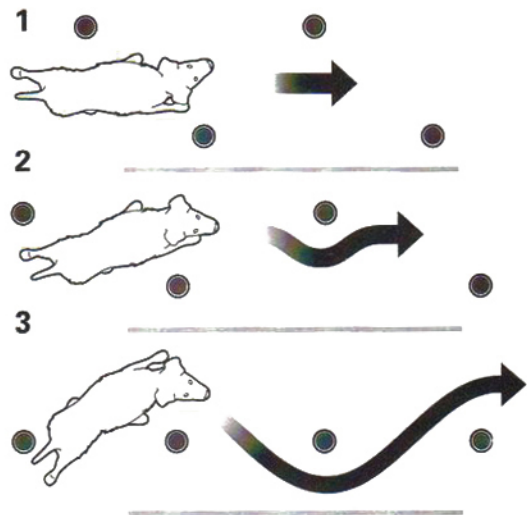

Aufbau

1. Drehen Sie die Erdnägeln in die Slalomstangen und ziehen sie die Schutzkappe ab.

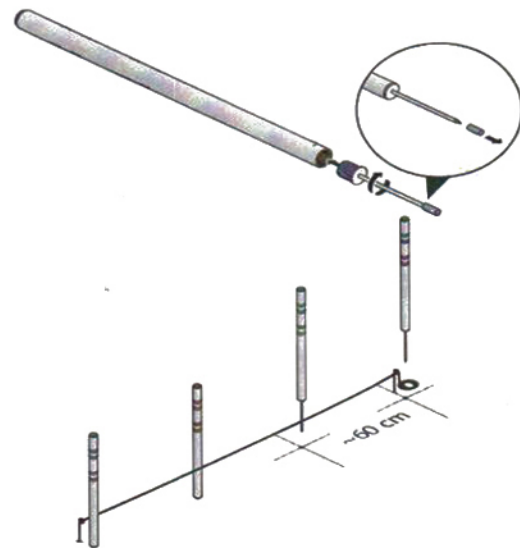

Teile

12X

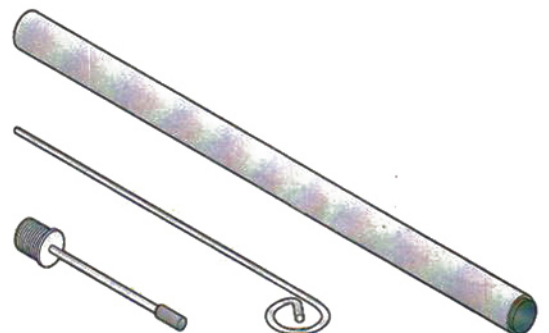

2x

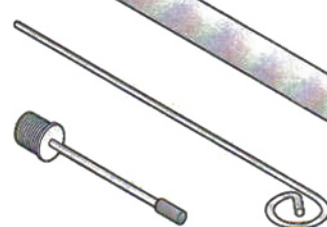

12X

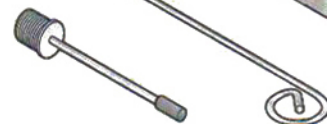

1x

