

HARVARD COFFEE TABLE

REF. HR902

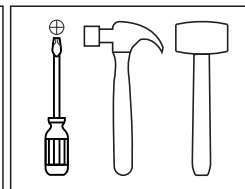
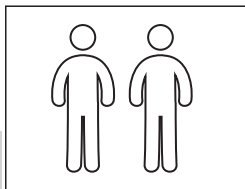

Thank you for choosing this furniture.

BEFORE YOU START ASSEMBLY please store the carton for 48 hours or more so the contents can acclimatise.

PLEASE RETAIN ALL PACKING UNTIL YOU HAVE COMPLETED ASSEMBLY.

Information about your furniture.

This furniture range has been carefully crafted from melamine faced manufactured board.

Each piece is manufactured to the highest standards using specialised computer controlled machinery to ensure accuracy.

Caring for your furniture.

Extreme temperature can cause slight movements in the board material so please avoid placing your furniture close to radiators or other direct sources of heat.

Please avoid exposing your furniture to continued bright sunlight as this can affect the colour.

Any fluid spills should be removed as quickly as possible.

Always lift your furniture when moving as dragging may cause damage to your furniture or flooring.

Always use place mats, coasters or tablecloths to help protect against scratches and accidentally dropped items. Always use heat resistant mats when placing hot or cold items on to surfaces.

Do not sit or stand on your furniture.

After care.

Wipe all surfaces with a dry cloth and the occasional use of a normal household furniture polish and a household glass cleaner on glass surfaces.

Please do not use detergents or chemicals on your furniture.

After assembly remove all visible component identification stickers, these should remove easily however any remaining adhesive residue can be easily removed with a label adhesive removal liquid available from most DIY or hardware stores.

Specialist glass care.

Glass can be marked with continual use by contact with rough surfaced objects or strong coloured fluids. In the unlikely event that the glass is damaged it must be replaced without delay with toughened glass made to specification BS EN12150. Please consult a specialist glass retailer for this.

Height: 396 mm
Width: 843 mm
Depth: 570 mm

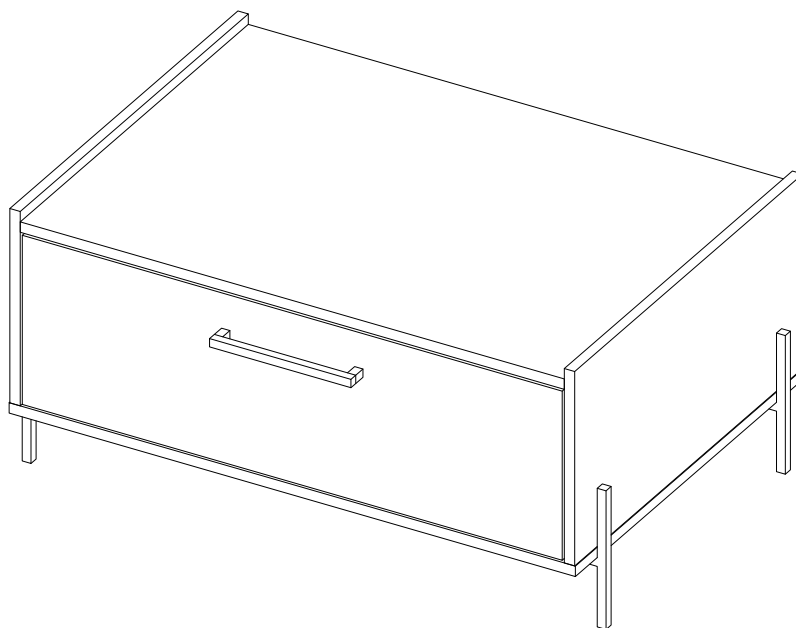

BEFORE YOU START ASSEMBLY

Please check that you have all the correct parts and fittings as detailed.

In the unlikely event that you require to order spare parts or fittings please refer to your delivery note for details of how to order using our Parts website.

www.coreproducts.co.uk/parts

Customer help line 01738 630555

We recommend that you build your furniture on top of a soft clean cover to ensure the unit does not get marked or damaged during assembly.

BATCH NUMBER

02/10/2020

PLEASE RETAIN THIS INSTRUCTION LEAFLET FOR FUTURE REFERENCE.

ASSEMBLY HARDWARE



x14
Dowel

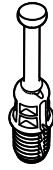

x14
Minifix Bolt



x14
Minifix Cams



(Colour 1)
x10
Cover Caps

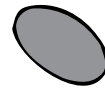

(Colour 2)
x10
Cover Caps

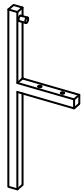

x4
Leg



x8
Drywall Screw
25,4mm

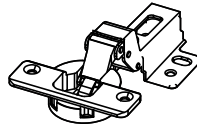

x2
Soft Closing End
Panel Hinge (SCEPH)
(Screws included)

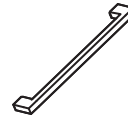

x1
Handle
(Screws
included)

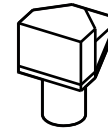

x1
Shelf support

ASSEMBLY PARTS

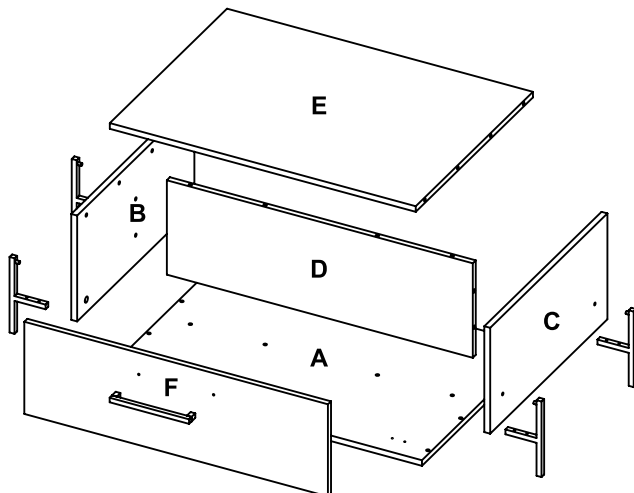

A - x1	D - x1
B - x1	E - x1
C - x1	F - x1

MAX SUGGESTED LOADS

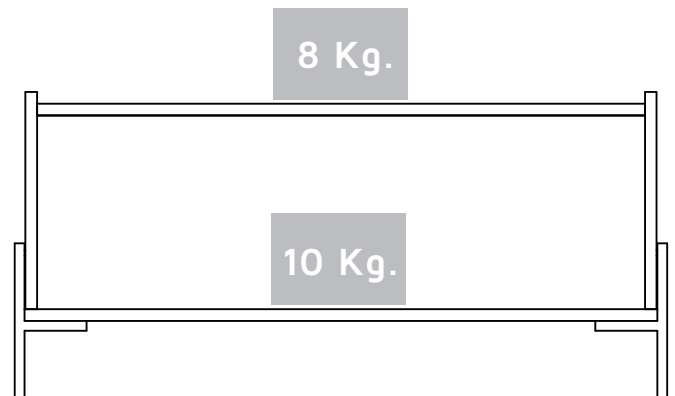

1

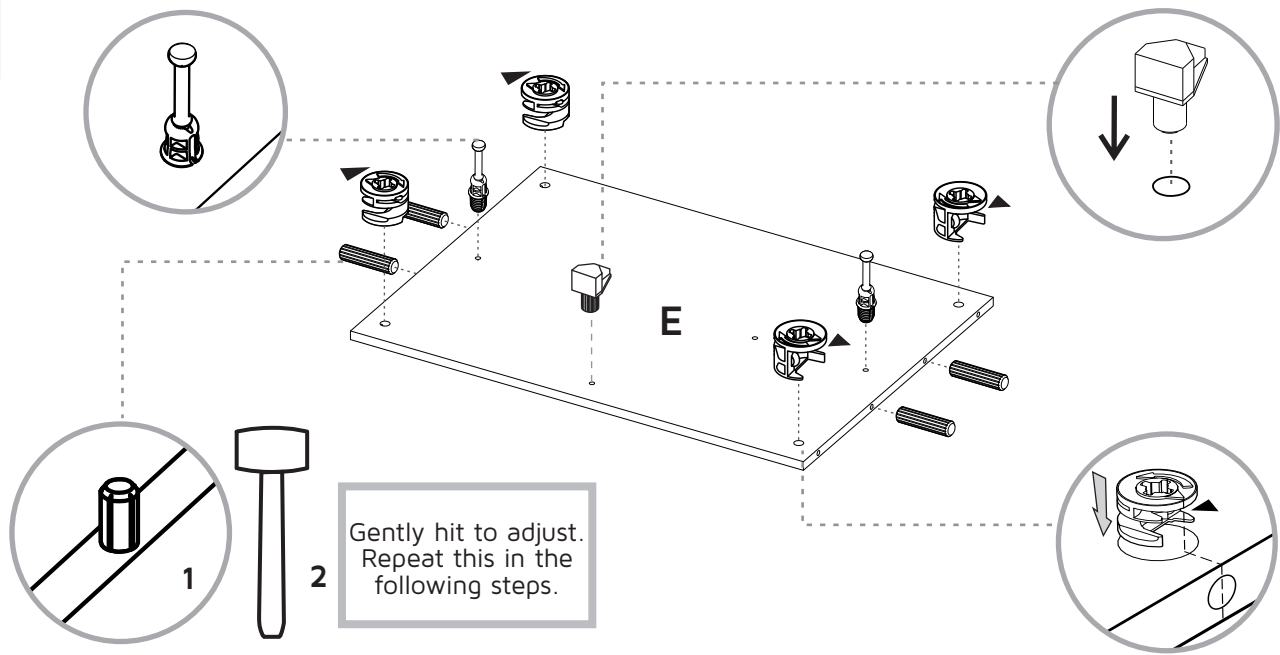

2

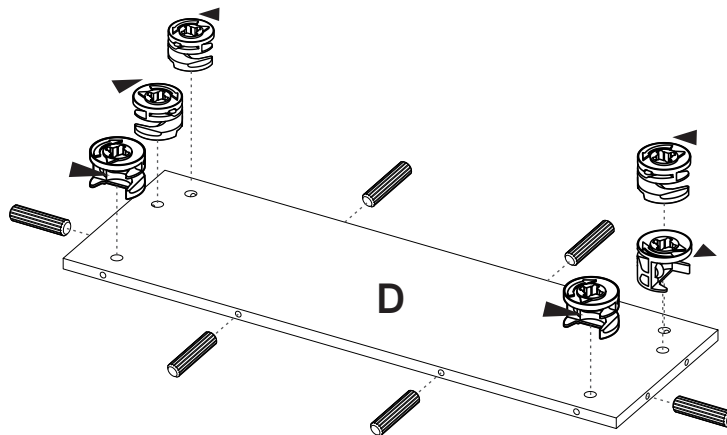

3

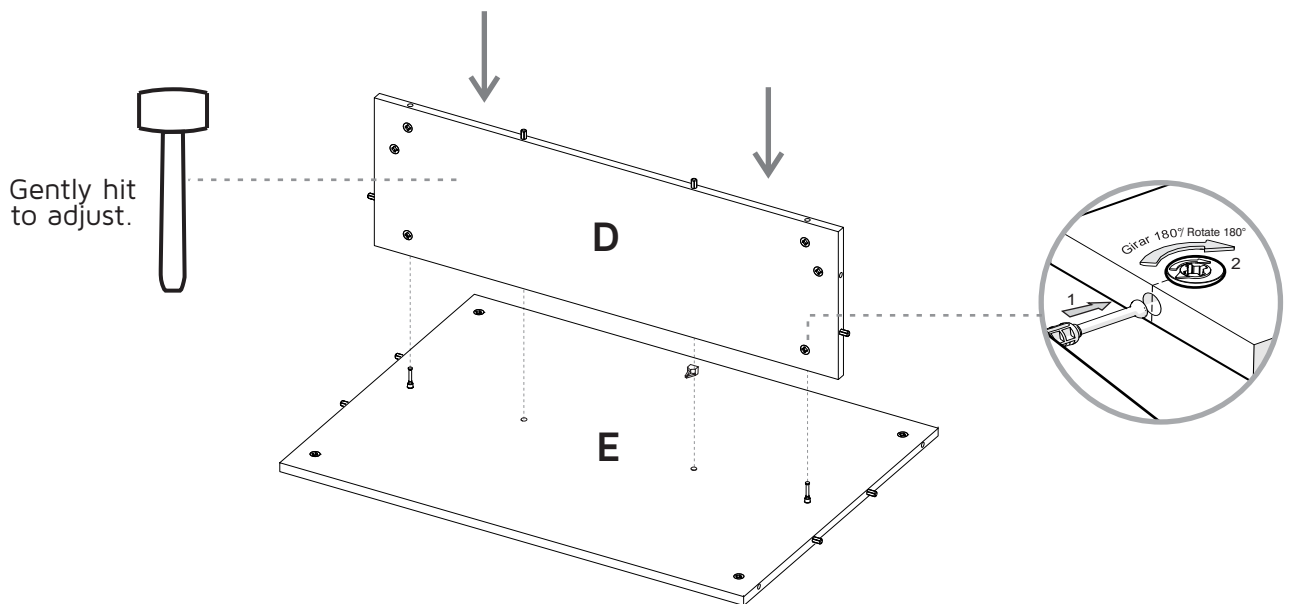

4

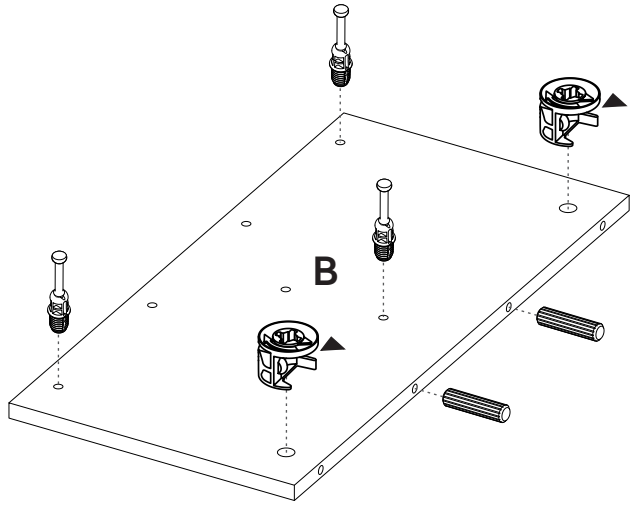

5

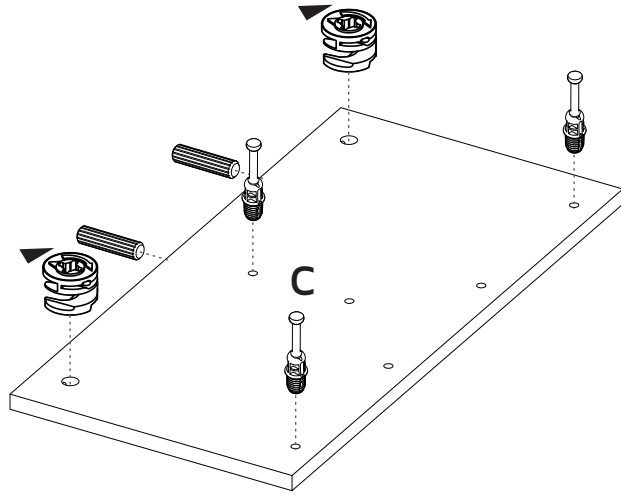

6

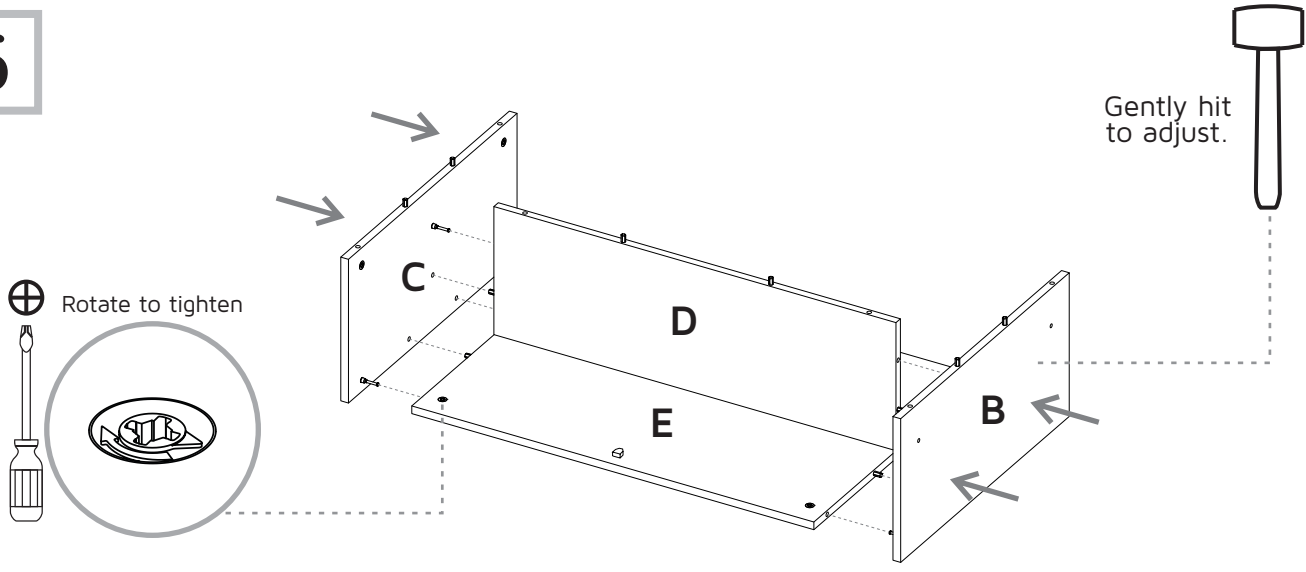

7

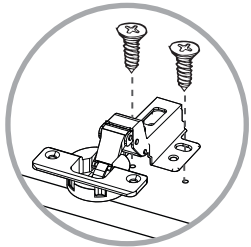
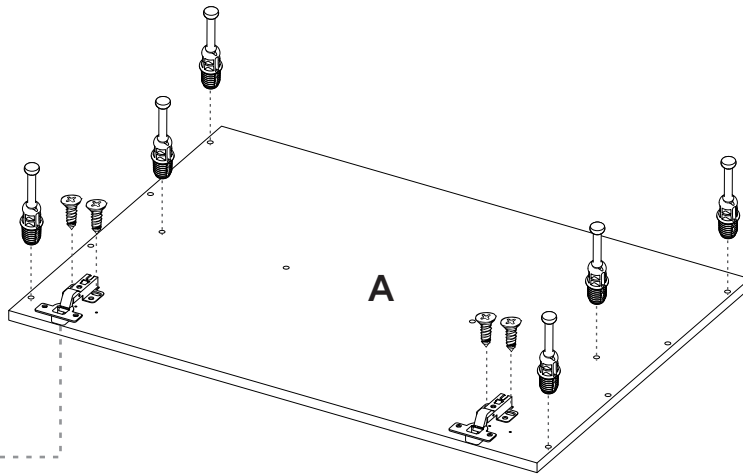

Soft Closing End Panel Hinge (SCEPH)

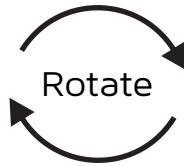

8

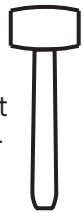
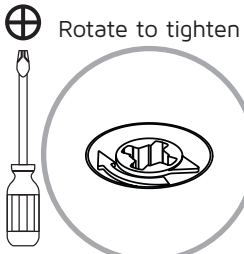
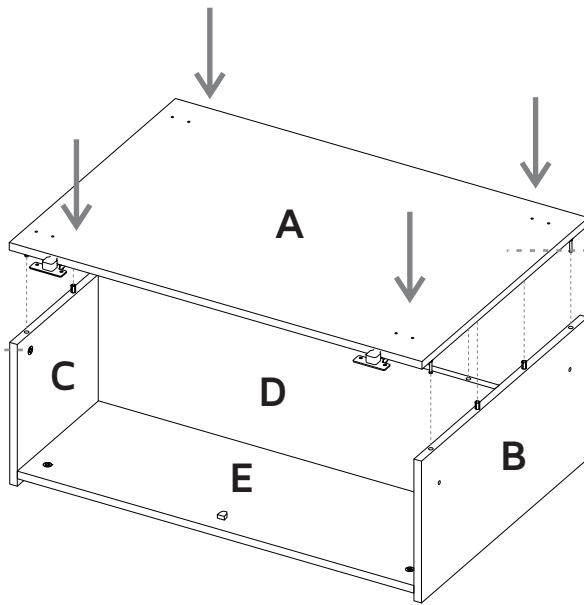

Gently hit to adjust.

9

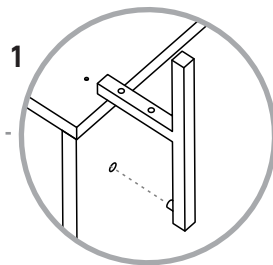
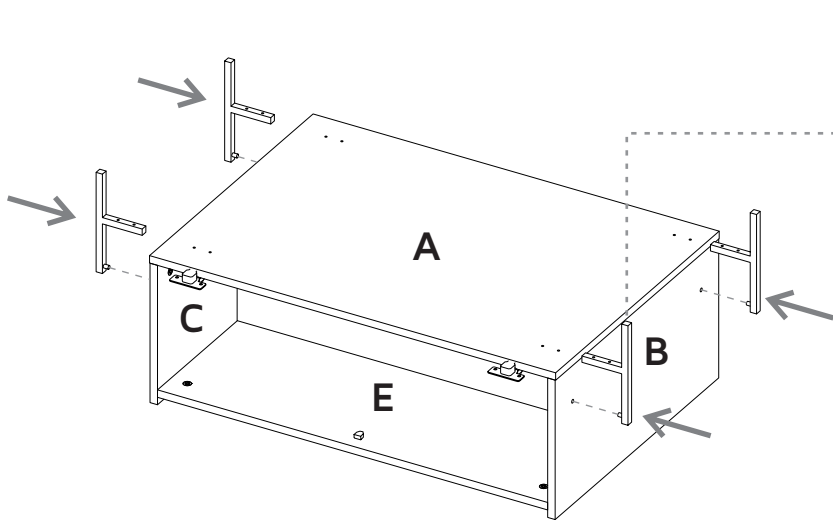

1 Insert into the hole

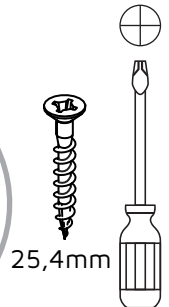
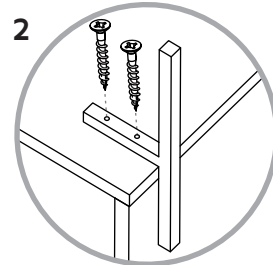

25,4mm

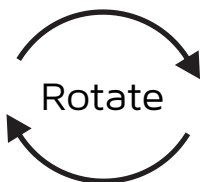

CAREFULLY FLIP THE CABINET

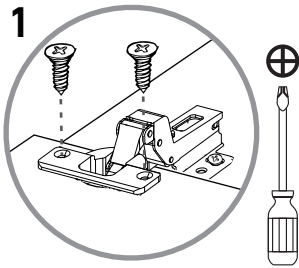
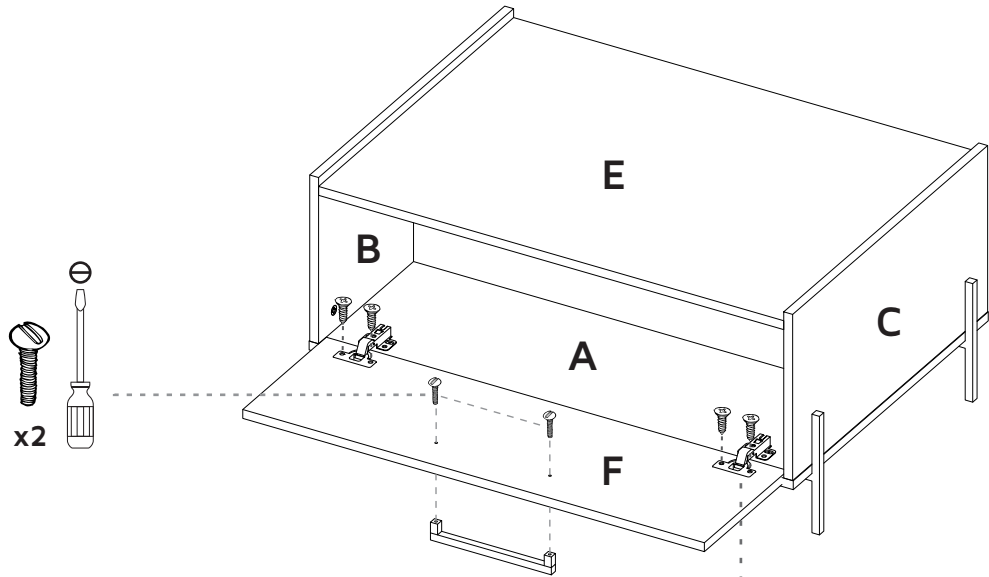

Hinge adjustment

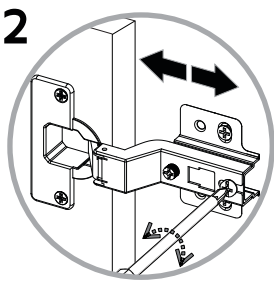

Depth adjustment

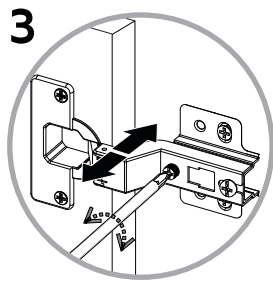

Side adjustment

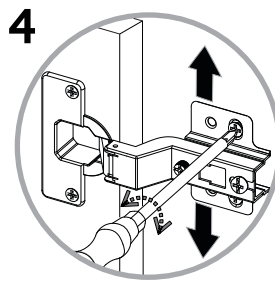

Height adjustment

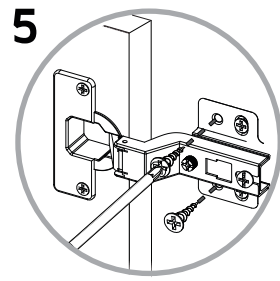

Secure Hinge

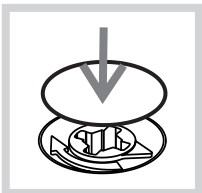

After you finish the adjustment of the cams, cover them with the cover caps.



After you finish assembling the cabinet, take off the adhesive letters.