

# REF. LD710

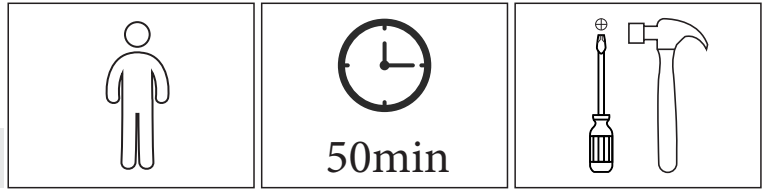

## flatscreen TV unit

### PLEASE USE THESE ASSEMBLY INSTRUCTIONS

Thank you for choosing this furniture.

**BEFORE YOU START ASSEMBLY** please store the carton at room temperature for 48 hours or more so the contents can acclimatise.

**PLEASE RETAIN ALL PACKING UNTIL YOU HAVE COMPLETED ASSEMBLY.**

#### Information about your furniture.

This furniture has been manufactured from surface coated wood based manufactured boards.

#### Caring for your furniture.

Extreme temperature can cause slight movements in the board material so please avoid placing your furniture close to radiators or other sources of heat.

Please avoid exposing your furniture to continued bright sunlight as this can affect the colour, any fluid spills should be removed as quickly as possible

Always lift your furniture when moving as dragging may cause damage to your furniture or flooring.

Use mats or coasters to help protect against heat.

Do not stand on your furniture .

#### Aftercare.

Wipe all surfaces with a dry cloth and the occasional use of a normal household furniture Polish, do not use detergents or chemicals on your furniture.

After assembly remove any visible component identification stickers, these should remove easily however any remaining adhesive residue can be removed with a label adhesive removal liquid available from most DIY or hardware stores.

For models with drawers we also recommend you use a household spray polish or curtain track spray on the drawer runner tracks. Please do not use any wax based products, chemicals or detergents on this furniture.

Regularly check all fixings to ensure they are tight.

#### BEFORE YOU START ASSEMBLY

Please check that you have all the correct parts and fittings as detailed on the assembly instructions.

We recommend that you build your furniture on top of a soft clean cover to ensure the unit does not get marked or damaged during assembly.

#### FOR DAMAGED/REPLACEMENT PARTS

Please visit

[www.coreproducts.co.uk/parts](http://www.coreproducts.co.uk/parts)

BATCH NUMBER **7262**

Height:500mm  
Width:900mm  
Depth:300 mm

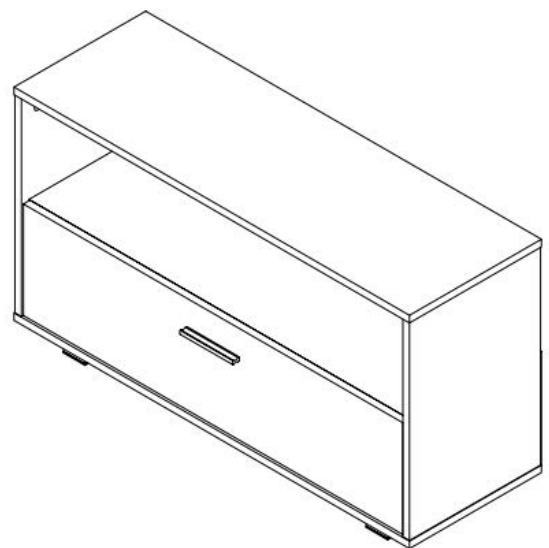







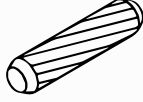

**PLEASE RETAIN THIS LEAFLET ALONG WITH YOUR DELIVERY**

**NOTE / RECEIPT FOR FUTURE REFERENCE.**

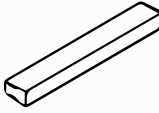
# FULLY INSPECT ALL PARTS BEFORE YOU START ASSEMBLY

## ASSEMBLY HARDWARE

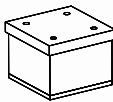
<p><b>A*12</b></p>  <p>40 mm</p>	<p><b>B*12</b></p>  <p>15 mm</p>	<p><b>C*12</b></p>  <p>8*40 mm</p>	<p><b>D*24</b></p>  <p>3.5*14 mm</p>	<p><b>E*14</b></p> 
<p><b>F*1</b></p> 	<p><b>G*2</b></p>  <p>3.5*18 mm</p>	<p><b>H*1</b></p>  <p>250 mm</p>	<p><b>I*8</b></p>  <p>3.5*35 mm</p>	<p><b>J*4</b></p> 

## ASSEMBLY PARTS

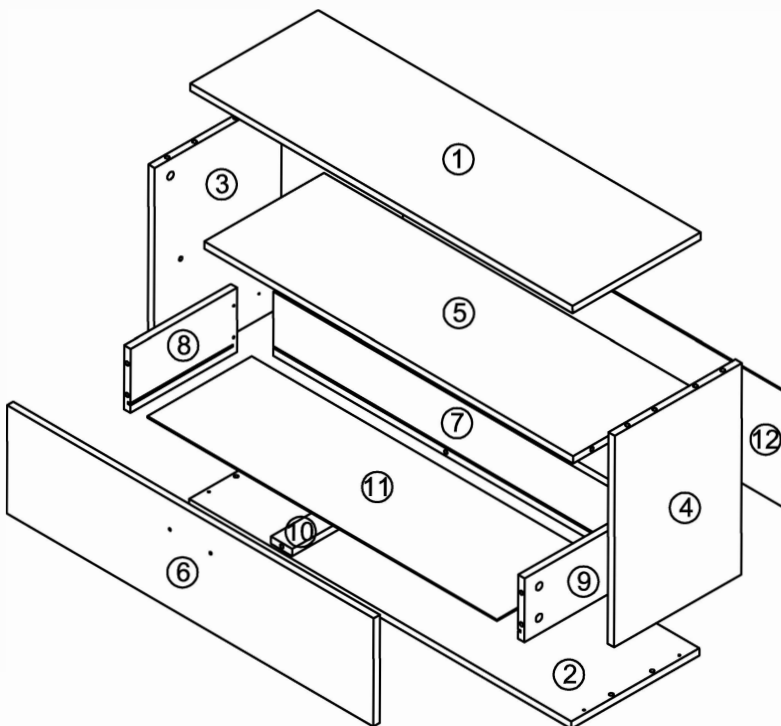

## MAX SUGGESTED LOADS

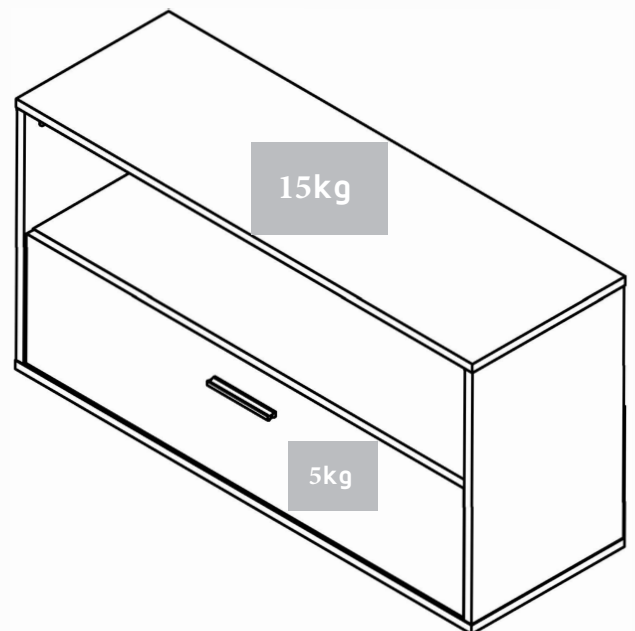

# IMPORTANT NOTICE

**BEFORE YOU START ASSEMBLY**

**REMOVE ALL PROTECTIVE FILMS FROM COMPONENTS**

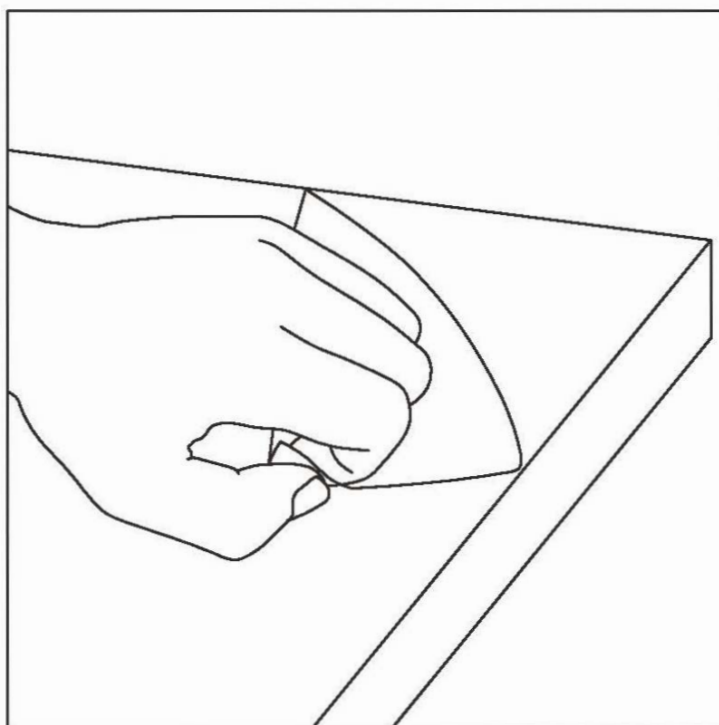
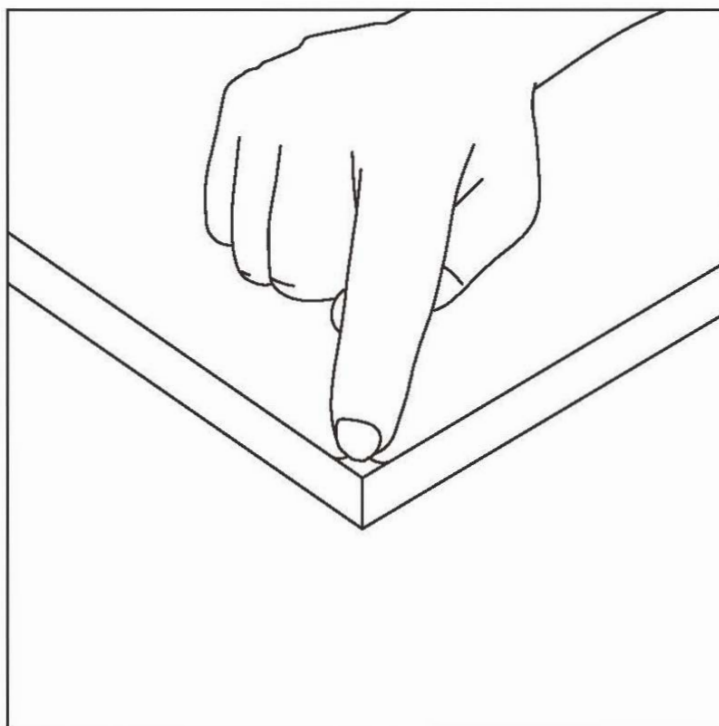

**ONCE FILM IS REMOVED FULLY INSPECT ALL PARTS BEFORE YOU START ASSEMBLY**

2

A\*4



40 mm

C\*4



8\*40 mm

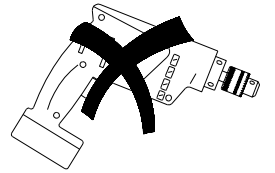
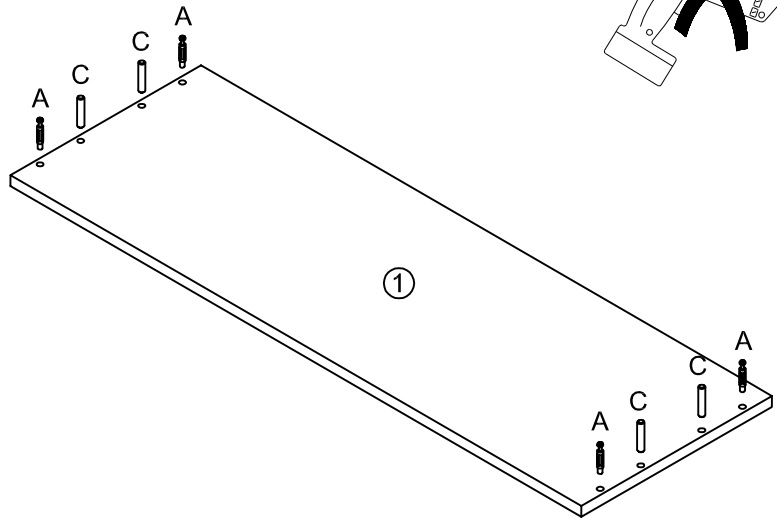

3

D\*16



3.5\*14 mm

J\*4

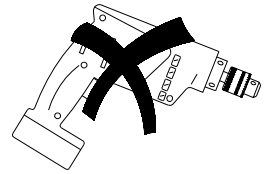
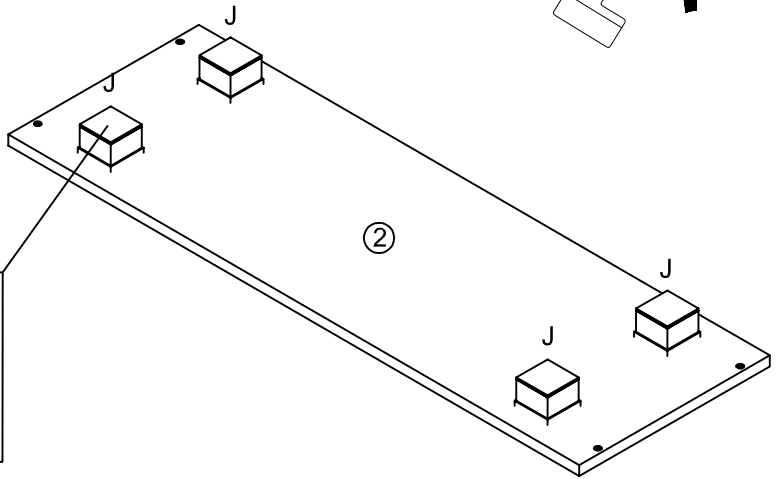
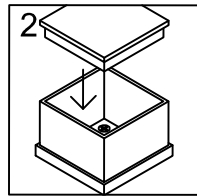
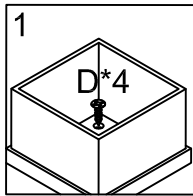
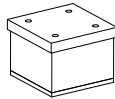

4

A\*4



40 mm

C\*6



8\*40 mm

D\*4



3.5\*14 mm

H\*1

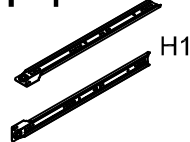

250 mm

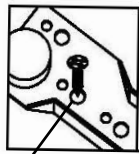

the second hole

Front edge

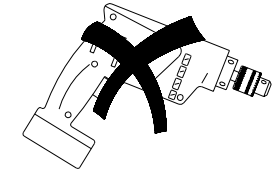
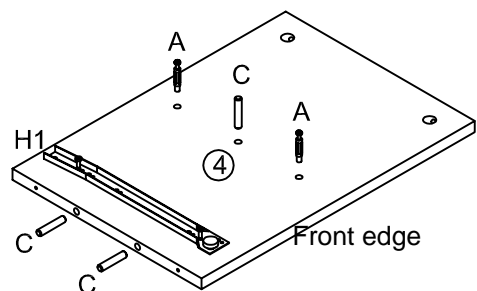
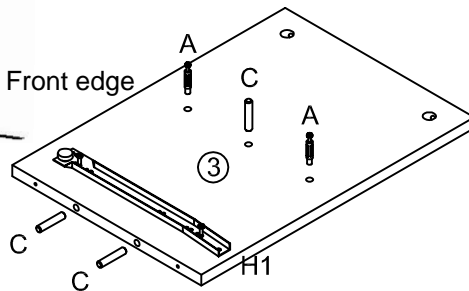

5

B\*4



15 mm

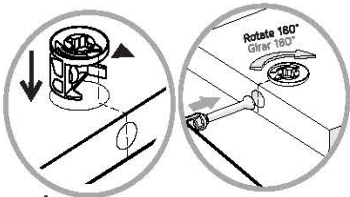

Turn minifix cams to the right to tighten.

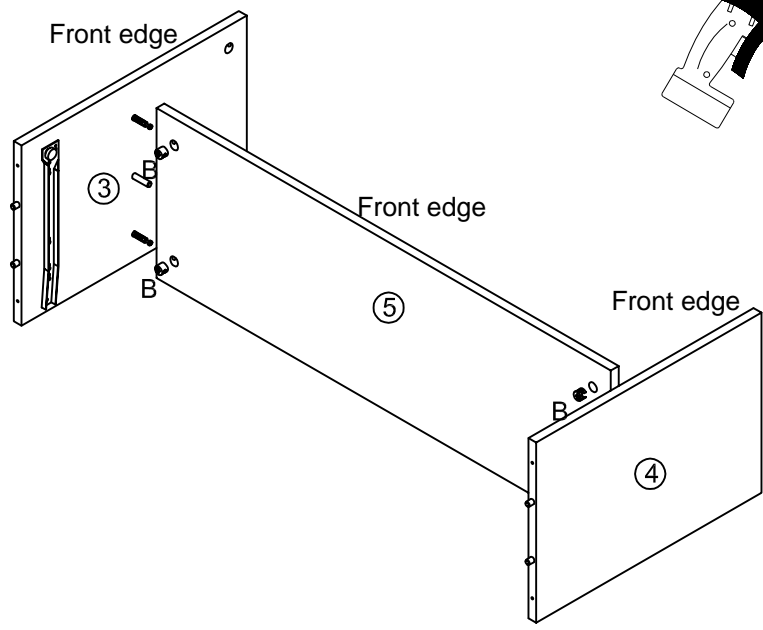

6

B\*4



15 mm

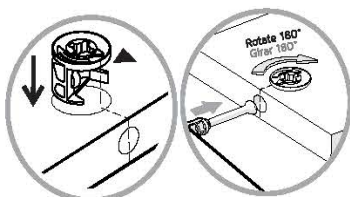

Turn minifix cams to the right to tighten.

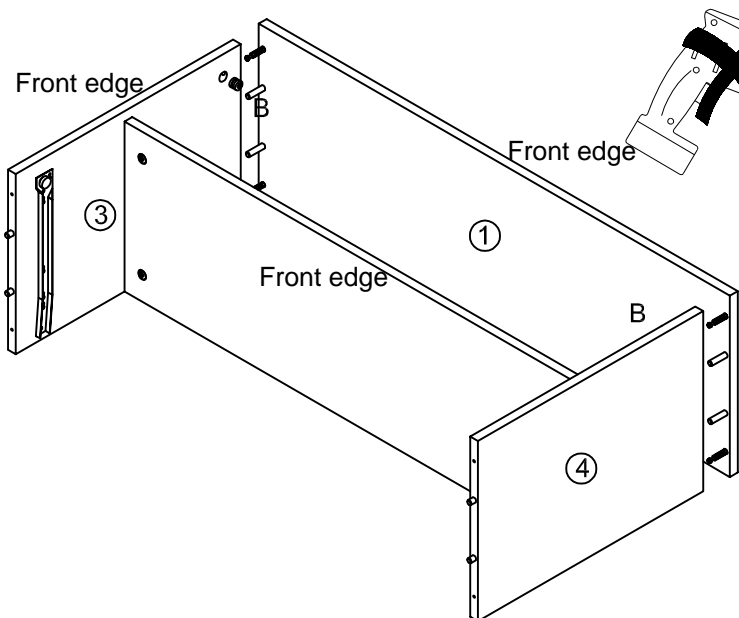

7

I\*4

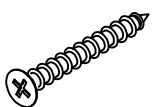

3.5\*35 mm

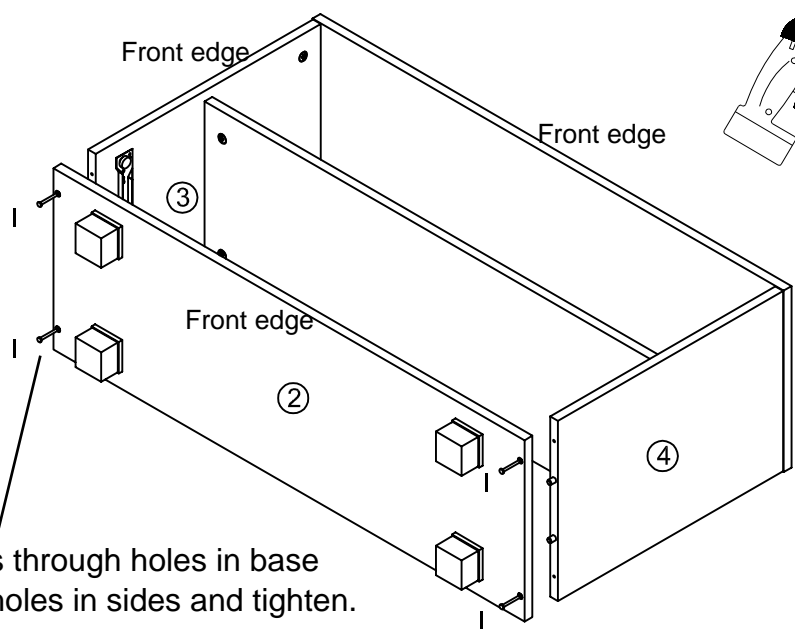

Insert all screws through holes in base into pre-drilled holes in sides and tighten.

8

E\*14

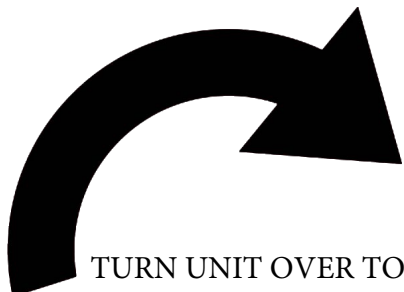
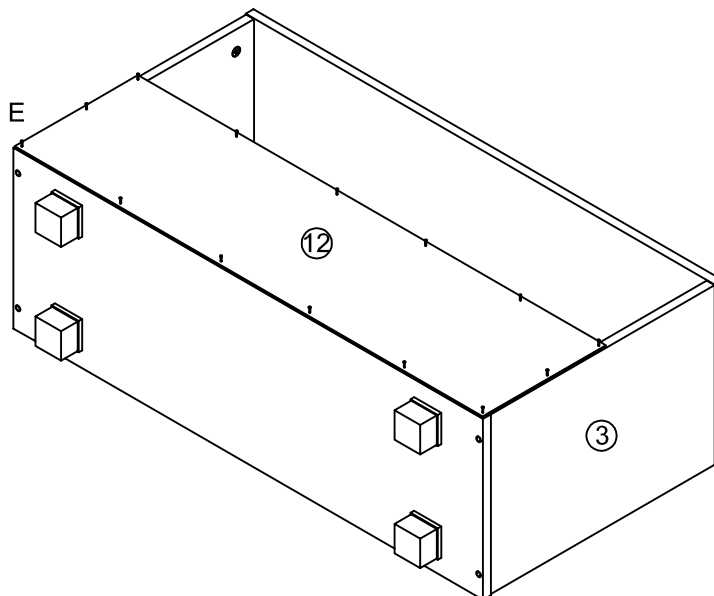

TURN UNIT OVER TO FIX BACK

9

A\*4



40 mm

C\*2

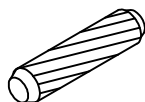

8\*40 mm

F\*1

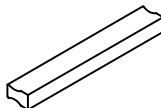

G\*2

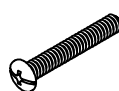

3.5\*18 mm

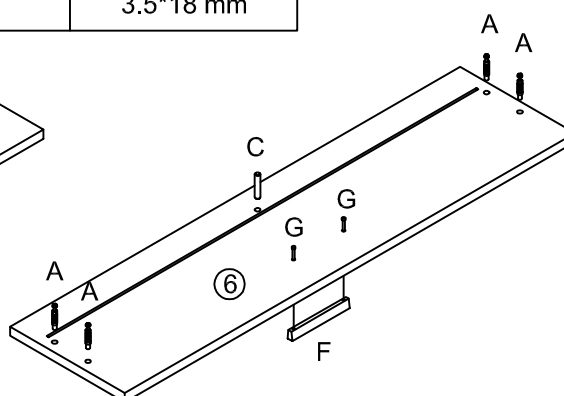
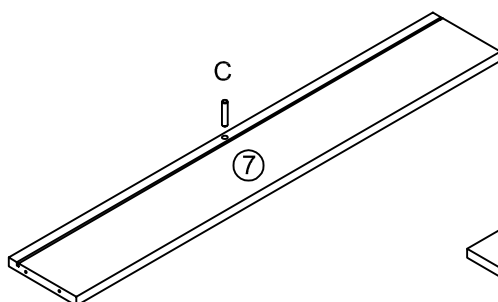
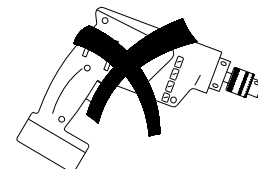

10

I\*4

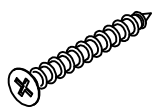

3.5\*35 mm

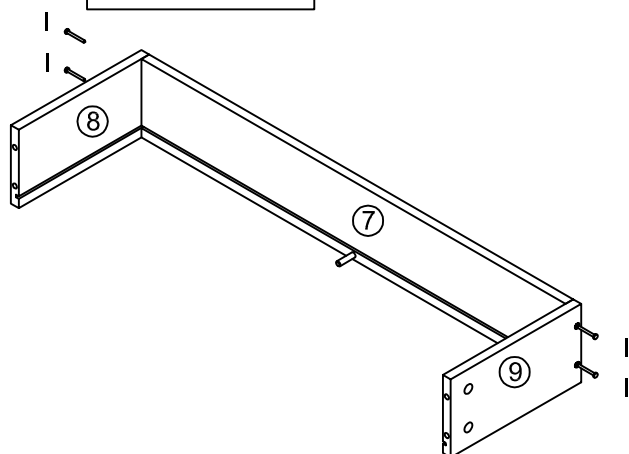
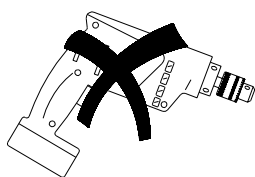

11

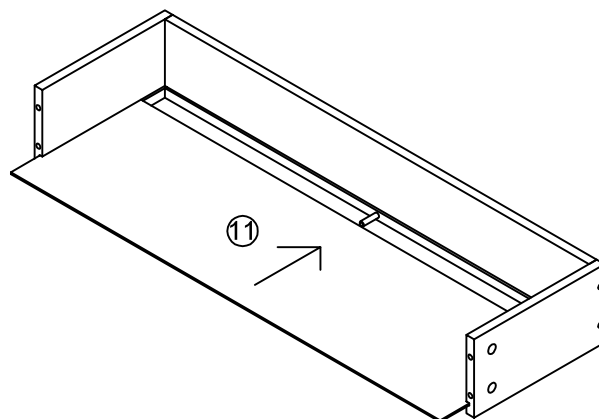

12

B\*4



15 mm

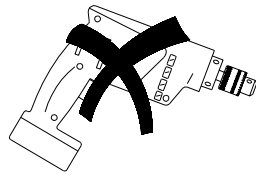

13

H\*1



250 mm

D\*4



3.5\*14 mm

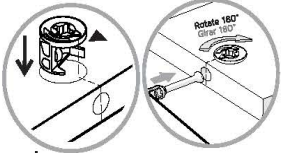
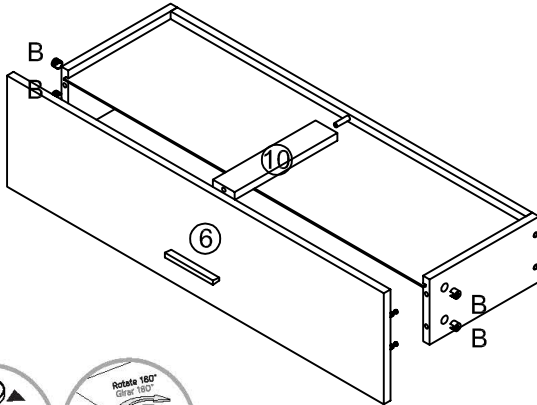

Turn minifix cams to the right to tighten.

14

Angle the drawer slightly to ensure that the wheel at the back of the drawer slide goes behind the front wheel on the cabinet slide. Then lift the drawer up and slide it into the channel of the drawer slide.

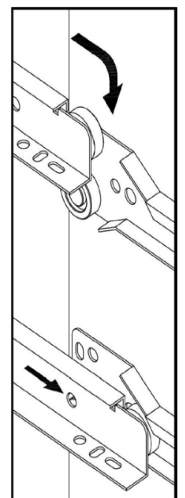
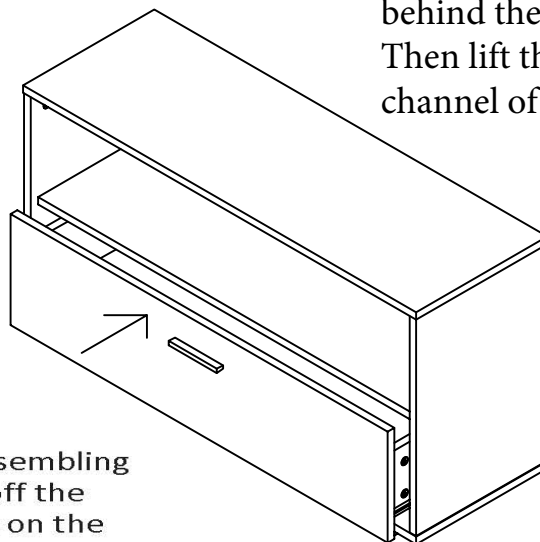

1

After you finish assembling the cabinet, take off the adhesive numbers on the parts' edge.

To avoid the risk of this unit falling forwards, especially in environments with children or uneven floors we recommend that this item is attached to your wall using appropriate fittings (not supplied).