

## 6. High level shelf

Position each shelf bracket at the desired height on the inside of the posts. Allow a gap at the back of the bracket for the shelf bracket back board to sit between and flush to the back edge of the posts. Secure each bracket using 2 x 40mm screws. When both brackets are in place fix the shelf bracket back board to the back edge of the brackets using 2 x 40mm screws at each end of the board. Screw the five hooks into your desired location. Place the two shelf boards on top of the brackets and secure each board at each end with 2 x 40mm screws.

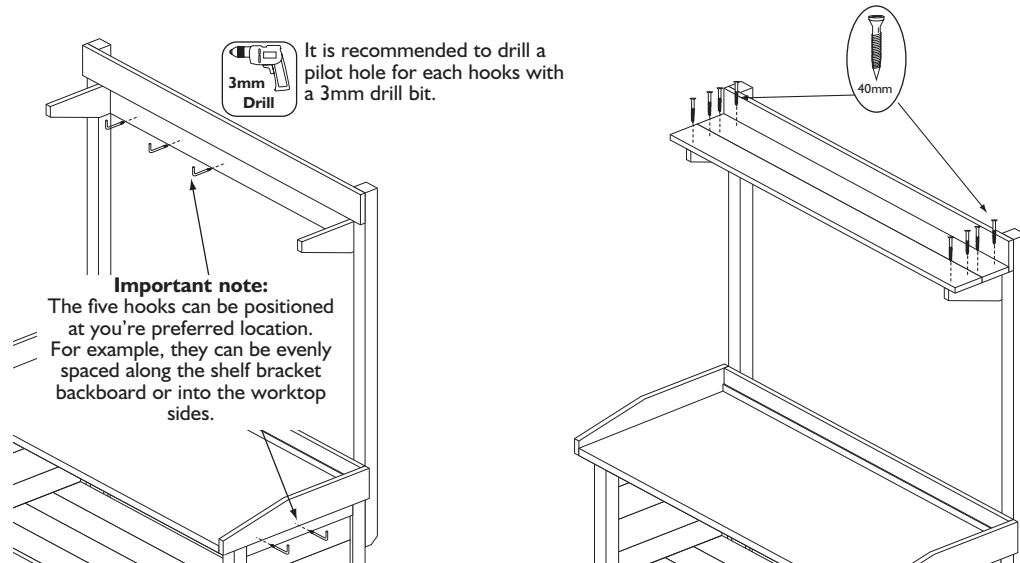
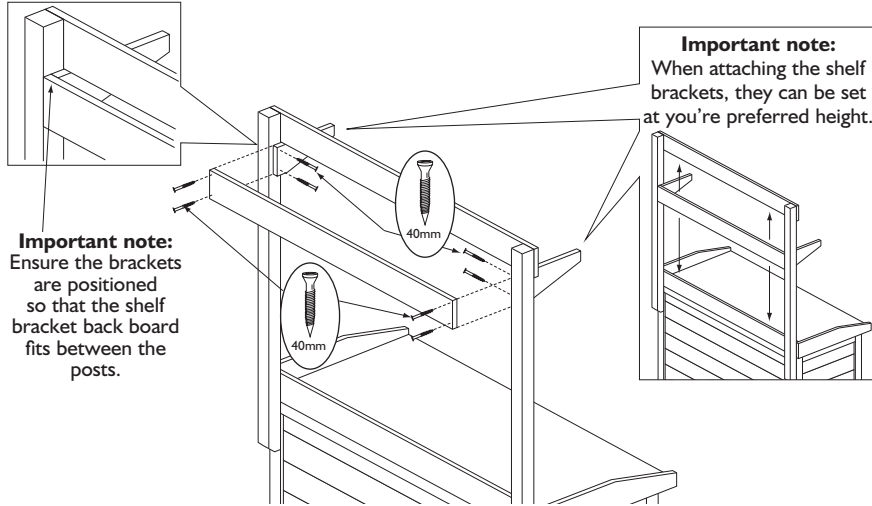

## Information

If in doubt of any aspect regarding the assembly, use or safety of your Multifunction Table, please contact us:

**Help Line (Normal Office Hours) 01829 261 121**

**Email: support@rowgar.co.uk**

ROWLINSON GARDEN PRODUCTS LIMITED  
Green Lane  
Wardle Nr. Nantwich  
Cheshire  
CW5 6BN  
[www.rowgar.co.uk](http://www.rowgar.co.uk)

We constantly improve the quality of our products, occasionally the components may differ from the components shown and are only correct at time of printing. We reserve the right to change the specification of our products without prior notice.

2022 © Rowlinson Garden Products Ltd

**ROWLINSON**  
GARDEN PRODUCTS

# Multifunction Table

# English SS305B

## Assembly Instructions

### Before assembly

- We recommend that time is taken to read the instructions before starting assembly, then follow the easy step by step guide. The instruction sheet is only a guide to the assembly. Certain items may not be shown to scale.
- Check all components prior to assembly
- This product should be assembled by no less than two people
- Drill all components where indicated
- Some of the components may have sharp edges wear protective work gloves while handling components.



### Recommended tools for assembly

- Power drill/screwdriver
- 3mm drill bit
- Cross head screwdriver bit
- Tape measure
- Rubber mallet
- Spirit level
- Sharp knife

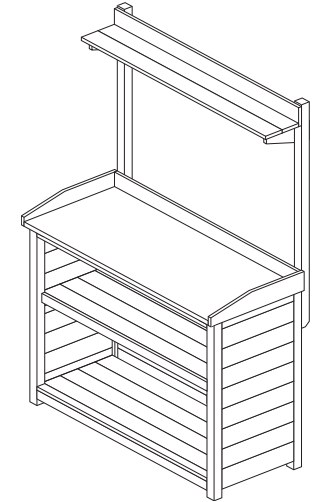
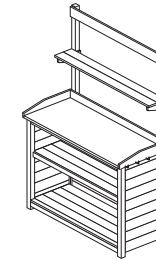

### Biocidal Products Regulation EU 528/2012

Wolmanit CX treated wood is a treated article that incorporates biocidal products: copper hydroxide carbonate/II and boric acid. They protect wood against fungal decay /rot/ and insect attack. Keep away from food, drink and animal feeding stuffs. Avoid breathing dust when cutting treated wood.

No.	Components	Qty.
1	Back panel	1
2	Left panel	1
3	Right panel	1
4	Front rails	2
5	Mid shelf support	2
6	Shelf	2
7	Shelf coverstrips	2
8	Work top	1
9	Metal work top	1
10	Work top sides	2
11	Work top back board	1
12	High level shelf posts	2
13	Shelf bracket	2
14	Shelf bracket back board	1
15	Shelf board	2
16	Shelf back board	1

No.	Fixing Kit	Qty.
17	Hook	5
18	90mm screw	16
19	40mm screw	39
20	30mm screw	4
21	14mm screw	6

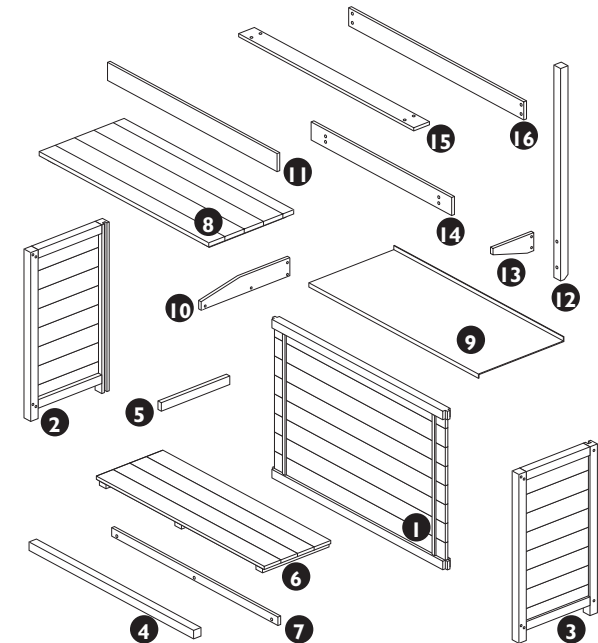

### 1. Back and side panels

Insert the back panel into the rebate on the back leg of each side panel. If necessary use a rubber mallet to tap into place. Secure each side panel in place using 2 x 90mm screws. Screw through the pre-drilled holes in the side panel into the ends of the back panel.

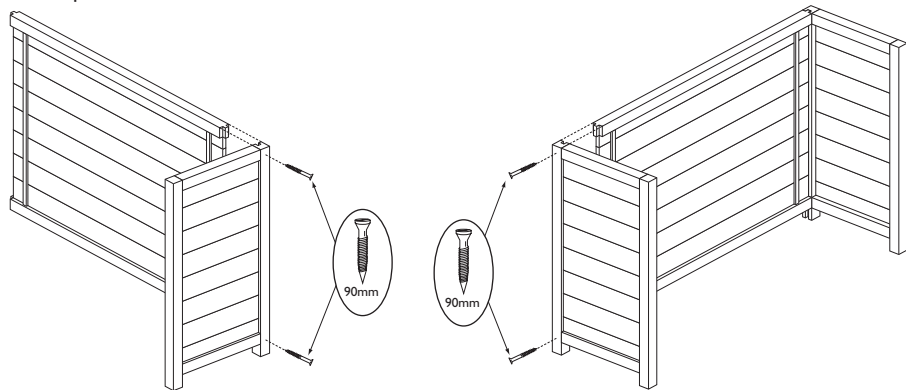

### 2. Shelves

Position the middle shelf supports at the desired height and attach to the inside of the side panels. Secure each one using 2 x 30mm screws, screw through the panel into the shelf support. Ensure both supports are at the same height. Insert a shelf at the bottom so that it rests on the frame of the side panels. Rest the second shelf on the middle shelf supports.

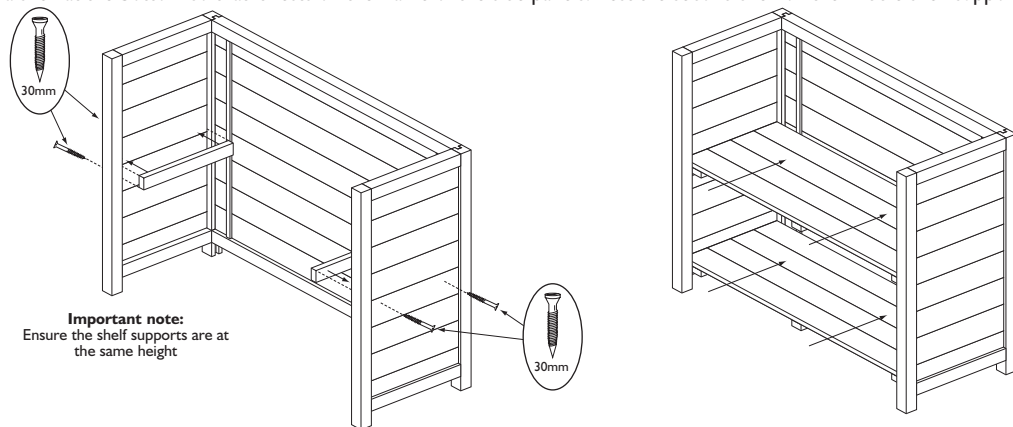

### 3. Front rails

Position the front rails between the side panels secure through the pre-drilled holes using 2 x 90mm screws at each end of each rail.

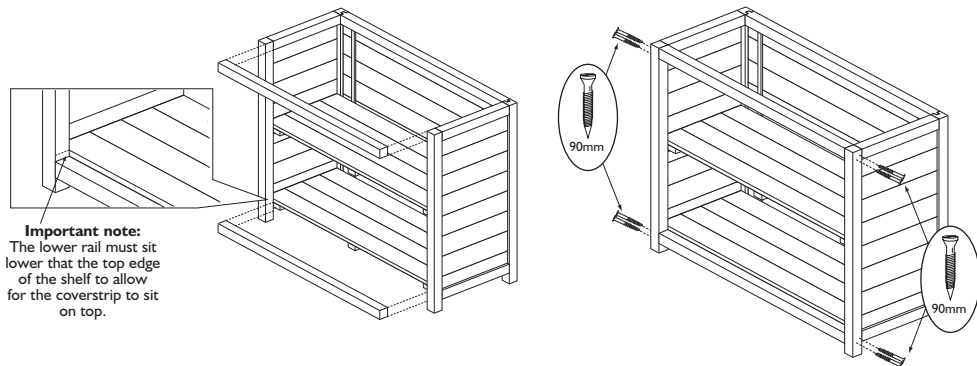

### 4. Work top and shelf coverstrips

Place the work top onto the assembly ensure it has an overhang at the front and a gap at the back to allow for the work top back board. Secure the work top down using 5 x 40mm screws. Attach the work top sides and back board using 4 x 40mm screws each side. Attach a coverstrip to the top of the lower front rail using 3 x 40mm screws. The remaining coverstrip is secured to the front edge of the middle shelf using 3 x 40mm screws. Place the metal work top onto the top of the assembly and secure in place using 6 x 14mm screws.

**Important note:**  
Ensure the work top overhangs at the front edge and there is a gap at the back to allow for the work top back board.

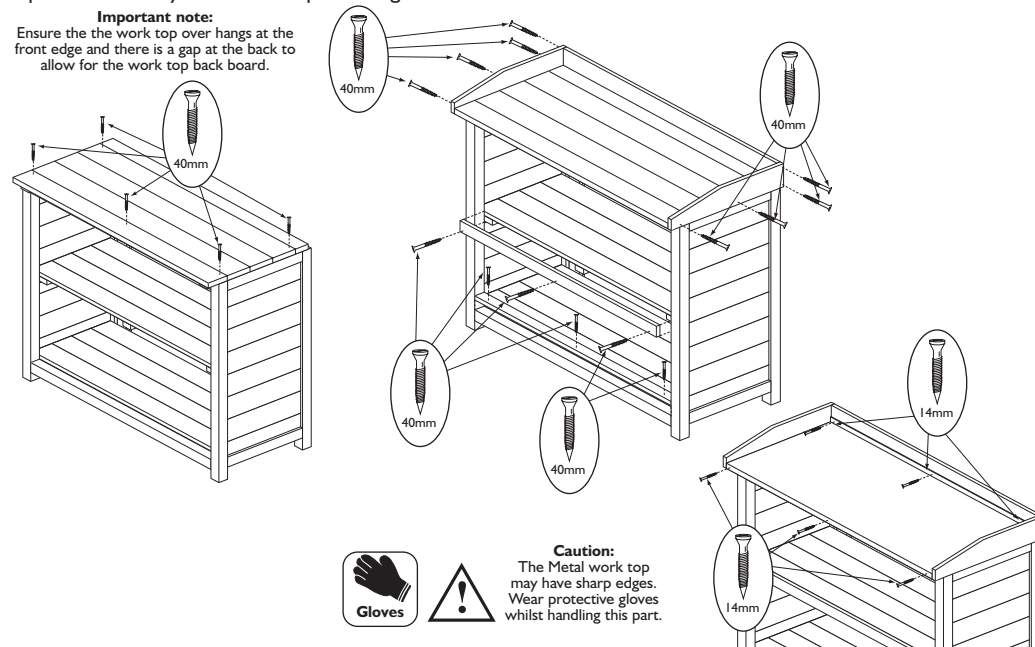

### 5. High level shelf posts

Determine the height you require the high level shelf and secure the shelf posts accordingly. Attach each post to the legs on the back of the assembly using 2 x 90mm screws per post. Fix the shelf back board to each post using 2 x 40mm screws.

**Important note:**  
Ensure the posts are at the same height

